



# GAS COUNTER TILTING SKILLET

Job \_\_\_\_\_  
Item# \_\_\_\_\_



*GCTS-16 with optional stand and faucet*

MODEL	CAPACITY		
	BTU	GALLON	LITER
GCTS-16	63,000	16	61

### OPERATION SHALL BE BY:

- Natural Gas
- L.P. Gas

Gas fired operating on 115 VAC, 1 phase, 50/60 Hz, rated at 63,000BTU.

### OPTIONAL ITEMS AT EXTRA COST:

- 220 VAC, 1 phase, 50/60 Hz
- Etched liter markings
- Correctional Package
- Steam pan insert (SPI-16S)
- One piece lift off stainless steel cover (SC-16S)
- 18" (460 mm) high floor stand c/w sliding drain pan and stationary drain (SD-30-16S)
- Single pantry faucet with 12" swing spout (SF-12)
- Double pantry faucet with 12" swing spout (DF-12)
- Single pantry rinse spray head, 68" hose, c/w bracket (SP-RSH)
- Double pantry rinse spray head, 68" hose, c/w bracket (DP-RSH)
- Stainless steel pour lip strainer (PS-16S)
- Faucet bracket (FB)

### SPECIFICATIONS:

Shall be a Crown Model GCTS-16, gas fired counter tilting skillet. The skillet shall be of one piece covered corner, 10 gauge type 316 stainless steel with a #4 exterior finish, a polished interior with etched gallon markings and covered corners for ease of cleaning. Cooking surface shall be of 3/4" triple-ply construction with 3/8" thick aluminum core ensuring even heat distribution over the entire cooking surface. Pan shall be fitted with side pivots mounted in sealed stainless steel clad consoles mounted on a 10 gauge stainless steel base with #4 finish. Pan shall be fitted with a stainless steel tilt handle with heat proof knob to tilt the pan forward for complete removal of contents and will include a damper control for tilt and return movements for ease of tilting. A tilt interlock shall prevent inadvertent tilting of the pan. Controls shall be integrally mounted and shall include a power switch, solid state thermostat, temperature pilot light, electronic ignition, ignition light, and a high limit temperature cut-off. Burner turns off automatically when pan is tilted. The skillet shall operate in a temperature range of 100°F to 450°F (38°C to 232°C). The skillet can be mounted on a 30-1/2" (775 mm) wide stainless steel stand with sliding drain pan and stationary drain.



Models:  GCTS-16

- ⚡ - Unless otherwise specified, Field Wire Electrical Connection to be 120 Volts, 60 Hertz single phase with grounding wire. Unit furnished with 8' cord and 3 prong plug. Total max. amps 2.0
- 🔥 - GAS CONNECTION: 3/4" pipe supply line required.
- 💧 - COLD WATER: 3/8" O.D. tubing to faucet (OPTIONAL)
- 🔥 - HOT WATER: 3/8" O.D. tubing to faucet (OPTIONAL)

MODEL	GAS SUPPLY				Use on non-combustible floors only.		
	WATER COLUMN PRESSURES		BTU/HR.	kW/HR.	MIN. CLEARANCE		SHIPPING WT.
GCTS-16	Natural min. 3.5"(89mm)	Propane min. 11"(279 mm)	63,000	18.5	SIDES	3 [76]	290 lbs. [132 kg] without stand.
					BACK	8 [203]	360 lbs. [164 kg] with stand.

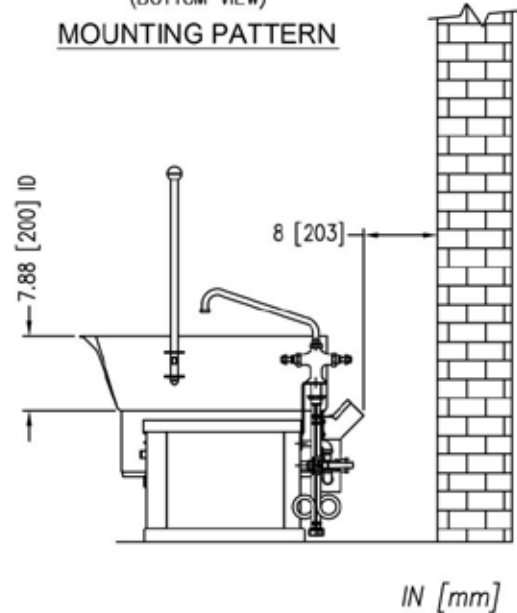
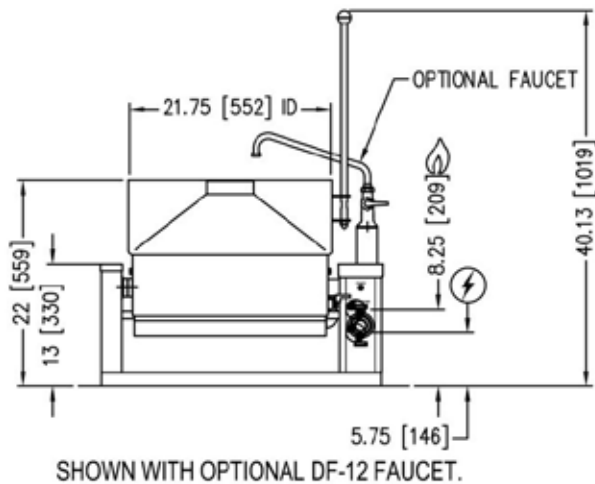
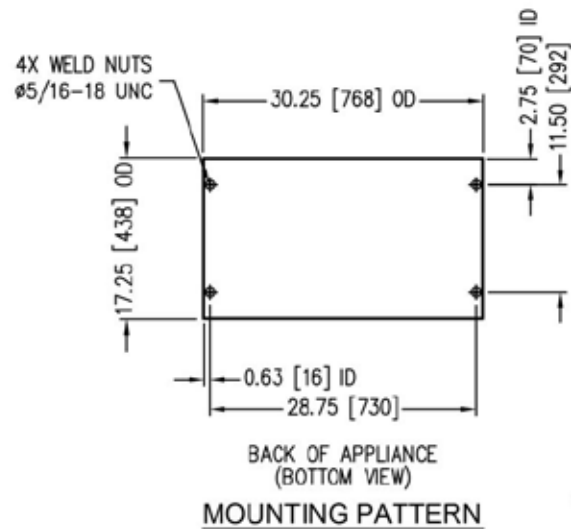
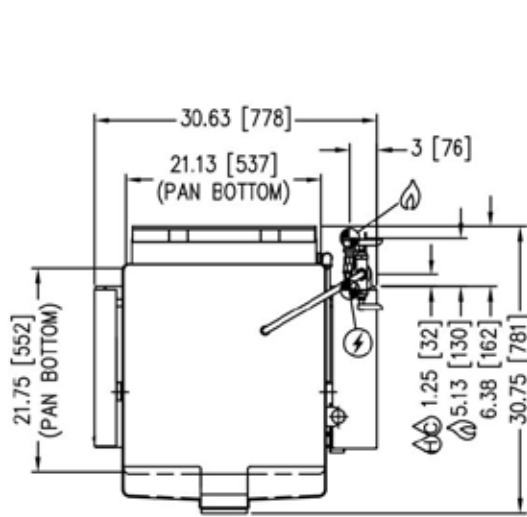

8403R1

As continued product improvement is a policy of Crown, specifications are subject to change without notice.

**INTENDED FOR COMMERCIAL USE ONLY.  
NOT FOR HOUSEHOLD USE.**



70 Oakdale Road, Toronto ON, Canada M3N 1V9  
(919) 762-1000 www.crownsteamgroup.com