

ELECTRIC STEAM "DO-ALL" COOKER WITH CABINET BASE

 EDA-2

 EDA-3

OPERATION SHALL BE BY:

Electrically heated steam boiler operating at 9-11 psi (62-76 kPa) and rated at 42 KW with automatic boiler blow down.

The steam boiler shall be equipped for operation on:

 208 VAC, 3 Phase, 50/60 Hz

 240 VAC, 3 Phase, 50/60 Hz

Standard Features

- Water Treatment System
- CSD-1 boiler controls
- Automatic boiler blowdown
- Split water line
- Water in "Y" strainer (condenser feed)
- Front flanged feet

OPTIONS & ACCESSORIES AT ADDITIONAL COST

 220 VAC, 1 Phase, 50/60 Hz

 220 VAC, 3 Phase, 50/60 Hz

 380 VAC, 3 Phase, 50/60 Hz

 415 VAC, 3 Phase, 50/60 Hz

 480 VAC, 3 Phase, 50/60 Hz

 415/240 VAC, 3 Phase, 4 wire

 380/220 VAC, 3 Phase, 4 wire

 575 or 600 VAC, 3 Phase, 60 Hz (EBVS-3)

 Stainless steel rear panel

 Single pantry spray hose and bracket.

 Double pantry spray hose and bracket.

 Sheet pan support (SPS-PC1 or SPS-PC2)

 Wire shelf rack (SSR-PC)

STANDARD CONSTRUCTION SPECIFICATIONS

Shall be a Model EDA-2or EDA-3, pressure and pressureless compartment cooker with electric steam boiler.

The cooker shall be constructed of all-welded satin finish stainless steel, type 304.

The doors shall have a removable inner liner of aluminum plate with full perimeter gasket seal, an outer liner of one-piece all-welded stainless steel, and a wheel-and-screw closing mechanism.

The doors, with a clear opening of 10-1/4" x 26-3/8", shall latch upon closing and shall open 15° upon latch release.

The lower compartment shall be a pressure cooker only and shall operate at a maximum pressure of 6 psi (41kPa).

The upper compartment shall be either a pressureless free venting cooker or a pressure cooker operating at a maximum of 6 psi (41kPa), as selected by the operator.

The control housing shall be constructed of stainless steel with a full-access removable panel.

Each compartment shall have independent automatic timer controls with visual and audible signals.

In the lower compartment and the pressure mode of the upper compartment, the controls automatically shut off and exhaust the incoming steam, drain

the condensate from the compartment and sound a continuous signal until turned off manually.

In the pressureless mode of the upper compartment, the controls shall also include a mode selector switch and a steam flow cut-off when the door is opened.

Each compartment shall be provided with universal pan supports. Each optional sliding shelf will support two full size steam pans

The compartment cooker shall be mounted on a cabinet base with full perimeter angle frame, reinforced counter and boiler mountings, electric boiler with controls which shall include the following as standard: water treatment system, automatic water level control, pressure gauge, water gauge glass, pressure control with secondary safety pressure control, air vent, safety relief valve, CSD-1 boiler controls, automatic boiler blow down, nickel plating, and split water line.

Thermostatically controlled cold water shall automatically condensate exhausted steam into water before releasing it to the drain.

The cabinet shall be all stainless steel #4 finish type 304, hinged doors and 6" (152mm) stainless steel legs fitted with 4 adjustable flanged feet for securing to the floor.

SEE REVERSE SIDE OF SPEC SHEET FOR WATER TREATMENT SYSTEM STATEMENTS



Approval Notes: _____

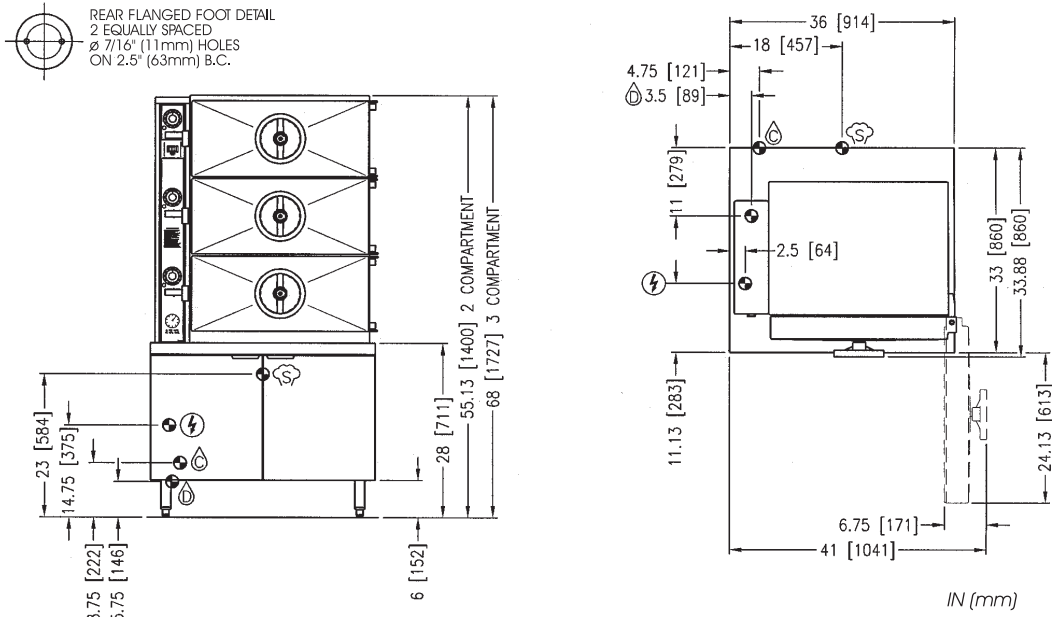

SERVICE CONNECTIONS

- COLD WATER: 3/8" O.D. tubing at 25-50 PSI (170-345 kPa)
- DRAIN: 2" (51 mm) IPS piped to open floor drain. No solid connection.
- ELECTRICAL CONNECTION: Field wiring electrical connection to be as specified on data plate.
- STEAM TAKE-OFF CONNECTION: 3/4" IPS optional to operate adjacent equipment.

ELECTRICAL CHARACTERISTICS

MODEL	PHASE	208V		220V		240V		380V		415V		480V	
		KW	AMPS	KW	AMPS	KW	AMPS	KW	AMPS	KW	AMPS	KW	AMPS
EDA-2 or EDA-3	3	42	116.6	42	110.2	42	101.0	42	63.8	42	58.4	42	50.5
	3	N/A	N/A	N/A	N/A	48	115.5	48	72.9	48	66.8	48	57.7

COMPARTMENT PAN CAPACITY

MODEL	COMPARTMENTS	CAPACITY
EDA-2	2	8-16 Pans
EDA-3	3	12-24 Pans

WATER QUALITY STATEMENT

Water is the essential ingredient in steam equipment, water quality is the major factor affecting the performance of your appliance. Crown Steam Group offers a Comprehensive Water Treatment System which exceeds our minimum water requirements. Proof of installation and proper cartridges replacement is required for warranty coverage. Water supply to Crown Steam Group steamers must be within these guidelines.

- Total dissolved solids.....Less than 60 PPM
- Total alkalinity Less than 20 PPM
- Silica..... Less than 13 PPM
- ChlorineLess than 1.5 PPM
- pH Factor6.8 - 7.3

Water which does not meet these standards should be treated with the installation of Middleby's Water Treatment System. Call 919-762-1000 if you have questions concerning your water meeting these parameters.

*Failure or malfunction of this appliance due to poor water quality is not covered under warranty.
Reference www.crownsteamgroup.com for complete warranty details and instructions.

DISCLAIMER

Terry System Cartridge Changes / Installation – "2-3 gallons of water MUST be purged at each cartridge change or new installation prior to water supply being fed to the steamer. Failure to do so can result in component damage within the steamer which is not covered under warranty. For additional guidance on proper installation, refer to install documentation provided with each Terry System and Replacement Cartridge Set."

**INTENDED FOR COMMERCIAL USE ONLY.
 NOT FOR HOUSEHOLD USE.**

