

# ELECTRIC COUNTER TILTING KETTLE



- EC-6TWL
- EC-10TWL
- EC-12TWL

### OPERATION SHALL BE BY:

Electrically, self-generating closed steam system equipped for operation on:

The kettle shall be equipped for operation on:

- 208 VAC, 1 or 3 phase, 50/60 Hz.
- 220 VAC, 1 or 3 phase, 50/60 Hz.
- 240 VAC, 1 or 3 phase, 50/60 Hz.
- 380/220 VAC, 3 phase, 4 wire, 50/60 Hz.
- 415/240 VAC, 3 phase, 4 wire, 50/60 Hz.

\* Phase is field convertible.

### Standard Features

- Low water level cut-off and indicator
- Pressure gauge
- Solid state temperature control.
- Safety relief valve.
- Type 316 stainless steel liner.
- 2/3 steam jacket.
- 50 PSI (345 kPa) high pressure operation for higher cooking temperature.
- Integrally mounted controls.
- Removable elements.
- "Clean lock" to hold kettle in cooking position or 105 for ease of cleaning.
- Stainless steel console and trunnion.
- Water resistant construction.
- Faucet bracket

### OPTIONS & ACCESSORIES AT ADDITIONAL COST

- |   |   |   |
|---|---|---|
| <input type="checkbox"/> Counter Steam Kettle Table (KT-) | <input type="checkbox"/> Etched litre markings (LM-)  | <input type="checkbox"/> Single pantry faucet with 12" swing spout, c/w bracket (SF-12) |
| <input type="checkbox"/> 380 VAC, 3 phase, 50/60 Hz.      | <input type="checkbox"/> Correction package.  | <input type="checkbox"/> Double pantry faucet with 12" swing spout, bracket (SF-12)     |
| <input type="checkbox"/> 415 VAC, 3 phase, 50/60 Hz.      | <input type="checkbox"/> One piece lift-off stainless steel cover (C-)                                    | <input type="checkbox"/> Single Pantry rinse spray head, 68" hose bracket (SP-RSH)      |
| <input type="checkbox"/> 480 VAC, 3 phase, 50/60 Hz.      | <input type="checkbox"/> Stainless steel perforated basket (SSB-)   | <input type="checkbox"/> Double pantry rinse head, 68" hose bracket (DP-RSH)            |
| <input type="checkbox"/> 600 VAC, 3 phase, 50/60 Hz.      | <input type="checkbox"/> 21" (530 mm high floor stand c/w sliding shelf (S-30)                            | <input type="checkbox"/> Contour measuring strip (CMS-)                                 |
| <input type="checkbox"/> Etched gallon markings (GM-)     | <input type="checkbox"/> 21" (530 mm) high floor stand c/w sliding drain pan and stationary drain (SD-30) | <input type="checkbox"/> Pour lip strainer (TKS-)                                       |

### STANDARD CONSTRUCTION SPECIFICATIONS

Shall be a Crown model EC-6TWL, EC-10TWL or EC-12TWL, self-generating, electric, counter, tilting kettle with tilt console on the left side.

A double wall kettle interior shall form a steam jacket around the lower 2/3 of the kettle.

The jacket enclosure shall contain distilled water which is factory sealed. The bottom of the kettle shall be of hemispherical design for superior heat circulation.

The stainless steel rectangular mounting base shall include the kettle mounting lugs concealed inside the enclosure.

A removable operating handle with heat proof knob shall be mounted on each kettle.

Construction shall be of all welded #4 finish stainless steel, type 304.

The interior cooking surface shall be of type 316 stainless steel for added resistance to corrosion.

The kettle shall be ASME Code stamped, National Board Registered, c-CSA-us and NSF certified.

The controls shall be water resistant, integrally mounted and shall include a power switch, solid state thermostat, pilot light, vacuum/pressure gauge, safety valve and low water shut off with low water light for each kettle.

The kettle shall operate in a temperature range of 165F to 285°F (74°C to 140°C) with a maximum pressure of 50 psi (345 kPa). The kettle shall be standard with removable elements.



Approval Notes: \_\_\_\_\_

\_\_\_\_\_

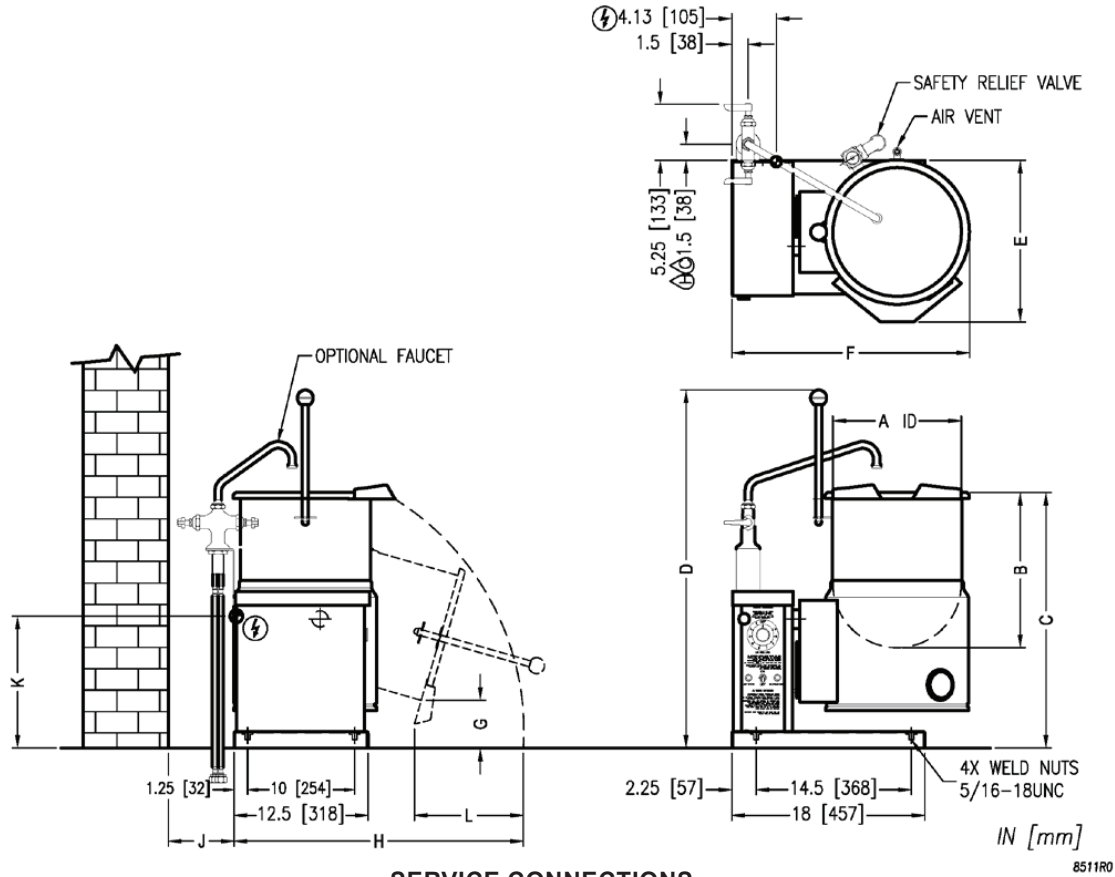

**SERVICE CONNECTIONS**

- ELECTRICAL CONNECTIONS: to be specified on data plate
- COLD WATER: 3/8" O.D. tubing to faucet (OPTIONAL)
- HOT WATER: 3/8" O.D. tubing to faucet (OPTIONAL)

**DIMENSIONS**

| Model    | Capacity                | Units      | A            | B               | C            | D               | E               | F               | G              | H            | J              | K               | L               |
|----------|-------------------------|------------|--------------|-----------------|--------------|-----------------|-----------------|-----------------|----------------|--------------|----------------|-----------------|-----------------|
| EC-6TWL  | 6 gallons<br>23 liters  | in<br>(mm) | 12"<br>(305) | 14.38"<br>(365) | 24"<br>(610) | 33.5"<br>(851)  | 15.25"<br>(387) | 22.25"<br>(565) | 4.50"<br>(114) | 27"<br>(686) | 4.25"<br>(108) | 12.38"<br>(314) | 10"<br>(254)    |
| EC-10TWL | 10 gallons<br>38 liters | in<br>(mm) | 16"<br>(406) | 15"<br>(381)    | 26"<br>(660) | 34.88"<br>(886) | 17.25"<br>(438) | 26.25"<br>(667) | 4.62"<br>(117) | 28"<br>(711) | 6.12"<br>(156) | 14.75"<br>(375) | 12.75"<br>(324) |
| EC-12TWL | 12 gallons 45<br>liters | in<br>(mm) | 16"<br>(406) | 17"<br>(432)    | 28"<br>(711) | 36.88"<br>(937) | 17.25"<br>(438) | 26.25"<br>(667) | 4.12"<br>(105) | 30"<br>(762) | 6.12"<br>(156) | 14.75"<br>(375) | 12.75"<br>(324) |

**ELECTRICAL CHARACTERISTICS AND SPECIFICATIONS**

| MODEL    | PHASE | kW   | AMPS PER LINE |      |      |      |      |      |      |
|----------|-------|------|---------------|------|------|------|------|------|------|
|          |       |      | 208V          | 220V | 240V | 380V | 415V | 480V | 600V |
| EC-6TWL  | 1     | 7.5  | 36.0          | 34.1 | 31.3 | -    | -    | -    | -    |
|          | 3     | 7.5  | 20.8          | 19.7 | 18.1 | 11.4 | 10.4 | 9.0  | 7.2  |
| EC-10TWL | 1     | 12.0 | 57.6          | 54.6 | 50.0 | -    | -    | -    | -    |
| EC-12TWL | 3     | 12.0 | 33.3          | 31.5 | 28.9 | 18.3 | 16.7 | 14.5 | 11.5 |

| Model    | Shipping Weight     | Minimum Clearance |               |                 | CAPACITIES |         |        |
|----------|---------------------|-------------------|---------------|-----------------|------------|---------|--------|
|          |                     | Right Side        | Left Side     | Back            | kW         | US Gal. | Liters |
| EC-6TWL  | 130 lbs.<br>[59 kg] | 0"                | 3"<br>(76 mm) | 2.5"<br>(64 mm) | 7.5        | 6       | 23     |
| EC-10TWL | 180 lbs.<br>[82 kg] | 0"                | 3"<br>(76 mm) | 2"<br>(51 mm)   | 12         | 10      | 38     |
| EC-12TWL | 190 lbs.<br>[86 kg] | 0"                | 3"<br>(76 mm) | 2"<br>(51 mm)   | 12         | 12      | 45     |

**INTENDED FOR COMMERCIAL USE ONLY.  
NOT FOR HOUSEHOLD USE.**

