



PASTA COOKER AND RINSE STATION



NOD14 / NODR14
(Pasta Cooker and Rinse Station Sold Separately)

- NOD14 - 12 gallon, 60 K BTU pasta cooker
- NODR-14 - 10 gallon rinse station

Typical Application

High production of dry and cooked pasta for individual and bulk preparation where space is a premium. The cooker is versatile in cooking a wide variety of pasta. The simmer mode is used to gently rethermalize cooked pasta or precooked foods prior to plating or pan sauteing.

Standard Features

- Marine grade stainless steel tank
- Stainless steel exterior cabinet
- Solstice burner technology, no blower or ceramics
- High efficiency design
- Self cleaning burner & down draft protection
- Digital controller with 4 button timer
- Drain "T" manifold (standard on NOD14 cooker/NODR14 rinse station)
- Manual water fill
- Tank overflow with screen
- Drain screen and clean out rod
- Tube rack (cooker)
- Removable basket hanger
- 9" adjustable legs for easier cleaning
- Single gas connection when ordering multiple cookers
- Faucet on rinse station

OPTIONS & ACCESSORIES AT ADDITIONAL COST

- | | | |
|--|--|---|
| <input type="checkbox"/> 6" Casters | <input type="checkbox"/> Round Basket - Reg. Mesh 4-5/8" | <input type="checkbox"/> Oblong Basket |
| <input type="checkbox"/> Small Bulk Basket | <input type="checkbox"/> Round Basket - Fine Mesh 4-5/8" | <input type="checkbox"/> Individual Serving Baskets and Rack |
| <input type="checkbox"/> Large Bulk Basket | <input type="checkbox"/> Round Basket - Reg. Mesh 6-1/4" | <input type="checkbox"/> Stainless Steel Tank cover for NOD14 |

STANDARD CONSTRUCTION SPECIFICATIONS

Construction:

Marine grade stainless steel tank on cooker and rinse station.
 Welded tank with an extra smooth peened finish ensures easy cleaning.
 Cabinet exterior constructed of stainless steel.
 1-1/4" (3.2" cm) full port opening drain valve
 Tank overflow prevents the water from flowing over the side of the tank and onto the floor.

Controls:

Digital Controller with precise temperature regulation for boil and simmer modes.
 Built in countdown timer is capable of storing 4 menu items on controller.
 Integrated BOIL/SIMMER switch allows you to easily select the desired cooking mode.
 Controller has an audible high temperature alarm.
 Temperature limit switch safely shuts off all heat if the upper temperature limit is exceeded.
 Integrated gas valve for safe operation.



Approval Notes: _____

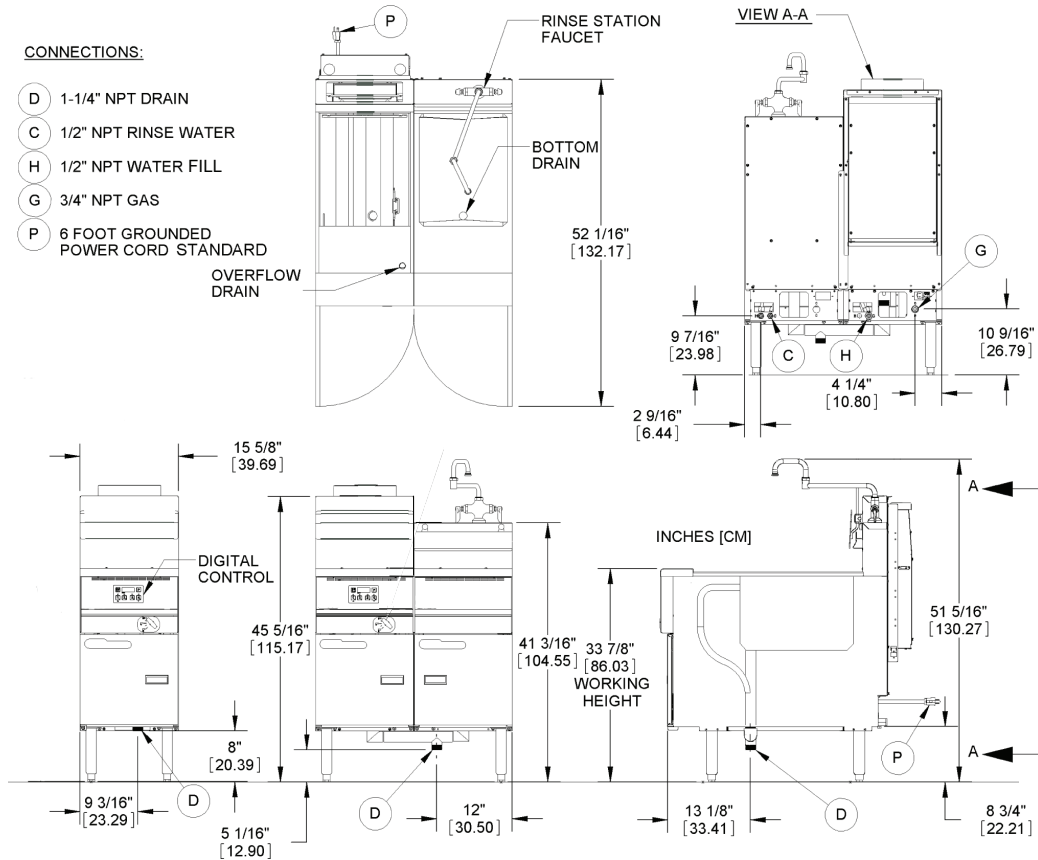

Dimensions shown in inches and (centimeters)

DIMENSIONS & WEIGHT

SHIPPING CRATE DIMENSIONS & WEIGHT								
MODEL	WEIGHT lbs(kg)	SIZE ft ³ (m ³)	MODEL	WEIGHT lbs(kg)	SIZE ft ³ (m ³)	MODEL	WEIGHT lbs(kg)	SIZE ft ³ (m ³)
NOD14	250 (113.4)	34.6 (1.0)	NOD14/ NODR14	376 (170.0)	53.5 (1.5)	NODR14	136 (61.7)	34.6 (1.0)

UTILITY INFORMATION

MODEL	WATER CAPACITY GAL (LITER)	COOKING AREA W x D [IN (CM)]	COOKING DEPTH IN (CM)	HEAT TRANSFER AREA (in ²)	GAS INPUT RATE / HR	ELECTRICAL AMPS 115V 60 HZ (208 / 220-240V 50-60HZ)
NOD14 (COOKER)	12 (45.5)	14" x 18" (35.6 x 47.7)	11-1/4" (28.6)	14" x 18"	60,000 BTU	1.0A (0.5A)
NODR14 (RINSE)	10 (37.85)	14" x 18" (35.6 x 47.7)	8-1/2" (21.6)	14" x 18"	N/A	N/A

MISCELLANEOUS

- If using Flex-Hose, the I.D. should not be smaller than 3/4" and must comply with ANSI Z 21.69
- If casters are used with flex hose, a restraining device should be used to eliminate undue strain on the flex hose
- For installation on combustible floors (with 6" high legs) and adjacent to combustible walls, allow 6" clearance.
- Install under vented hood

- Check local codes for fire, installation and sanitary regulations.

NOTICE:

Southbend has a policy of continuous product research and improvement. We reserve the right to change specifications and product design without notice. Such revisions do not entitle the buyer to corresponding changes, improvements, additions or replacements for previously purchased equipment.

**INTENDED FOR COMMERCIAL USE ONLY.
NOT FOR HOUSEHOLD USE.**

