



Product Specifications

23 cu ft Freezer

CFZ527: Freezer



Designed in partnership with industry-leading Italian commercial manufacturer, Desmon.



CFZ527

Project:

Notes:

Features and Specifications

Stainless steel
Volume of 23 cu ft
Electronic digital temperature control with alarms
Autodefrost
Epoxy coated, sealed evaporator eliminates potential corrosion
High efficiency evaporator coil & condenser
Factory pre-wired for dedicated outlet
Includes 3 epoxy coated wire shelves
Key lock
LED lighting
Dimensions: 82 9/32" H x 26 25/32" W x 31 1/2" D
Temperature range: 14°F - (-13°F)
High efficiency compressor with 5.2 running amps
Environmentally friendly R290 refrigerant

Model Details

Model	Description	Voltage/Hz	Shipping Weight
UCFZ527-SS31A	23 cu ft Freezer, Field Reversible Hinge	115v / 60hz	297 lb

Accessories

Model	Description	Shipping Weight
ULAQ32-0002	Epoxy Coated Wire Shelf (20.86" x 25.6")	2.2 lb
ULA89010340	Caster Kit	11.02 lb



Product Specifications • 23 cu ft Freezer

Front (Open)

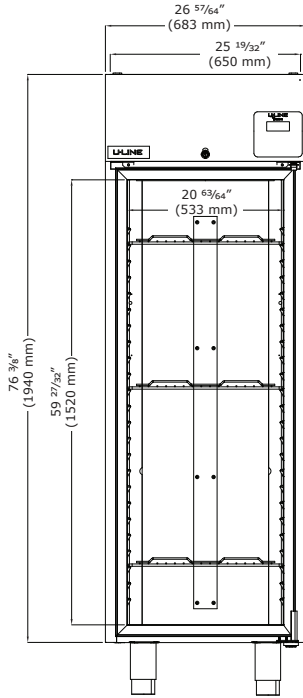

Front (Closed)

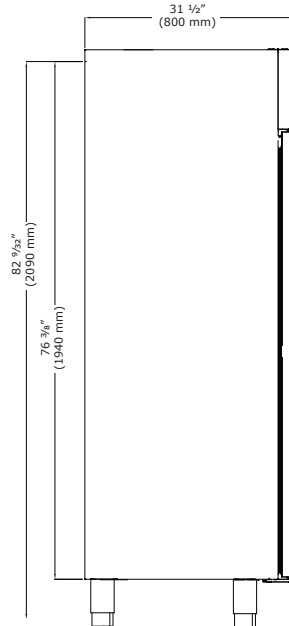

Top

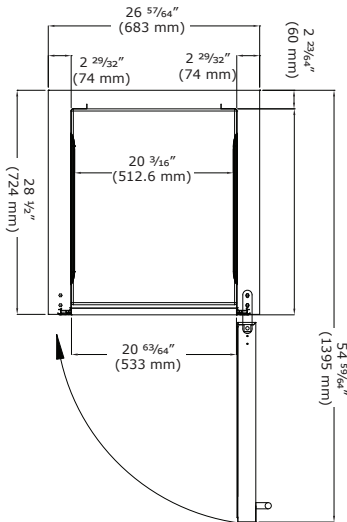

Side

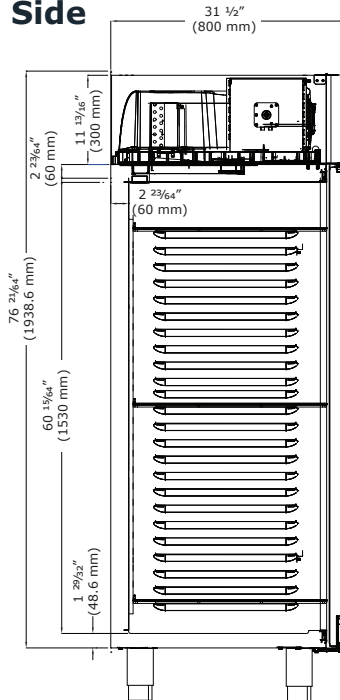

Commercial Warranty

1 Year (parts & labor) / 5 year sealed system (parts)
See complete warranty for details

