

Unpack and Install System

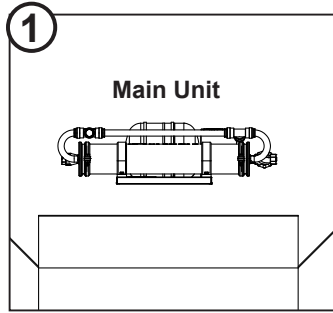

Unpack carton and identify parts.



Identify location to install the system.

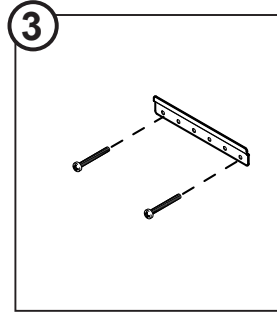

Mount the wall bracket.

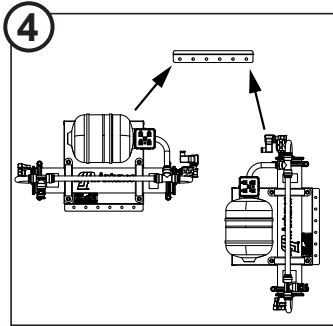

Hang system.

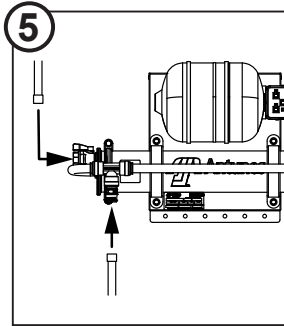

Connect inlet and outlet plumbing.

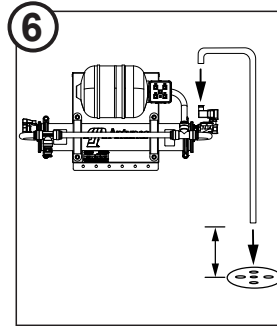

Install drain line to drain.

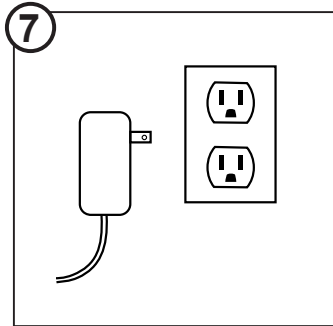

Plug power supply into outlet.

Rinse Ultrafilter

NOTE: Ultrafilter must be rinsed before use.

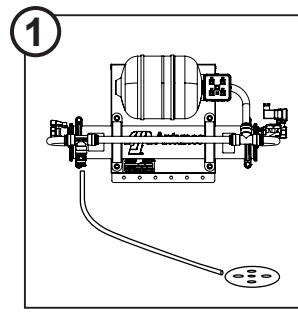

Connect RINSE hose.

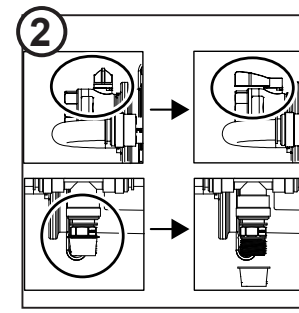

Open outlet valve and INLET valve.

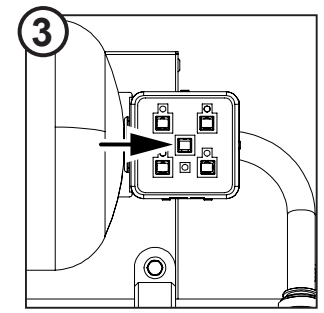

Push FLUSH button 6 times.

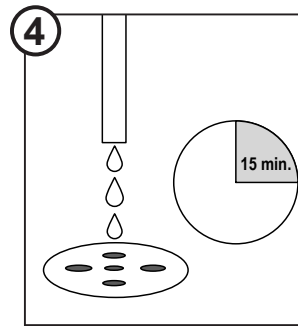

Rinse for 15 minutes.

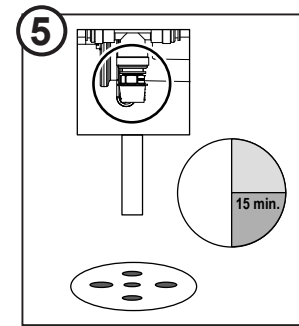

Close outlet valve and wait 15 more minutes.

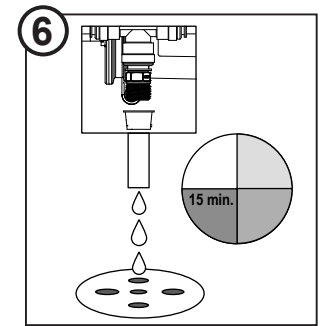

Open RINSE valve and rinse for 15 minutes.

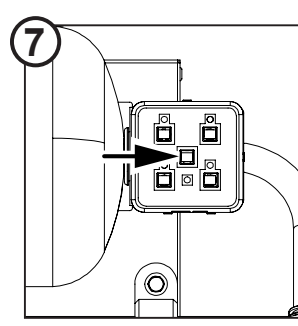

Push FLUSH button 6 times.

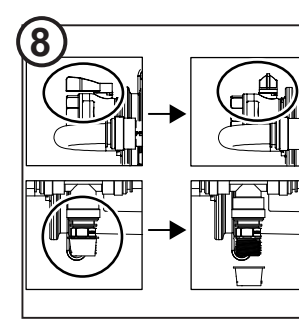

Close INLET valve and open outlet valve.

NOTE: Consult Owner's Manual for detailed steps.

ANTUNES www.antuneswater.com 180 Kehoe Blvd., Carol Stream, Illinois 60188

Rinse Ultrafilter (Cont.)

NOTE: Ultrafilter must be rinsed before use.



Sanitize system.

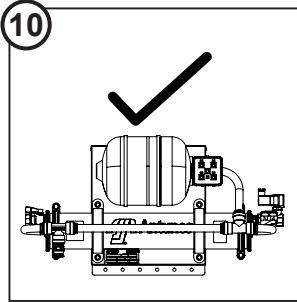

System is ready for use.

Maintenance

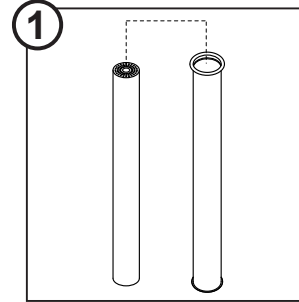

Change Ultrafilter cartridge every 3 years.