

Deb Tucker's

Pint Size Wing Clipper

Basic Instructions

A Trim Down Tool for Traditional Flying Geese Units

High Precision ♦ 8 Different Sizes
 For Small Units in 1/4" Increments
 Right & Left Handed Instructions

Studio 180
Design

Studio180Design.net

Eighth Inch Wing Clipper® Basic Instructions

The **Pint Size Wing Clipper®** is used to create traditional Flying Geese units. The finished size of these units will be twice as wide as they are tall. The construction method uses one large and four small squares to make four Flying Geese at a time. The large square becomes the four large triangles in your Flying Geese, and the four smaller squares become the eight side triangles. Once the Flying Geese are sewn, the **Pint Size Wing Clipper®** tool is used to trim each to its exact size, with the seams going directly into the corners. This is a terrific way to make precise units quickly and accurately!

Flying Geese Unit Basics

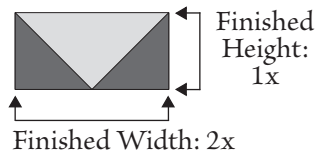

Starting Squares:
 1 Large, 4 Small

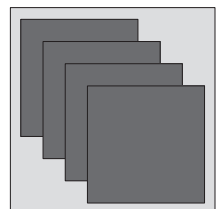

Eighth Inch Wing Clipper® Cutting Chart

Finished Size of Flying Geese	Cut Size of Flying Geese	Tool Section for Trimming	Cut Size of Large Squares	Cut Size of Small Squares
½" x 1"	1" x 1½"	I	2½"	1½"
¾" x 1½"	1¼" x 2"	II	3"	1¾"
1" x 2"	1½" x 2½"	I	3½"	2"
1¼" x 2½"	1¾" x 3"	II	4"	2¼"
1½" x 3"	2" x 3½"	I	4½"	2½"
1¾" x 3½"	2¼" x 4"	II	5"	2¾"
2" x 4"	2½" x 4½"	I	5½"	3"
2¼" x 4½"	2¾" x 5"	II	6"	3¼"

Flying Geese Construction Process

Step 1 - Position two of the smaller squares right sides together in diagonally opposite corners of the one large square. Nudge them in towards the center just a few threads.

Step 2 - Mark two lines, each ¼" away from a center diagonal. I like to use my **Quilter's Magic Wand™** and a fine line marking tool. The **Quilter's Magic Wand™** keeps my seam allowances from getting too wide and a fine line gives me better accuracy.

Step 3 - Stitch on both of the drawn lines, then cut between the lines of stitching on the center diagonal.

Step 4 - Press seams toward the smaller triangles (I do this no matter which is dark or light).

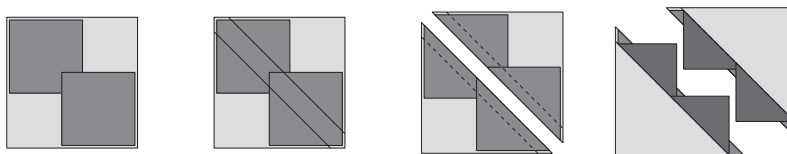

Steps 1-4 - Position, Mark, Stitch, Cut, and Press

Step 5 - Position one small square in the corner of the previously pieced units. Nudge the squares in like you did before.

Step 6 - Mark two lines, each ¼" away from a center diagonal. Use the **Quilter's Magic Wand™** and fine line marker.

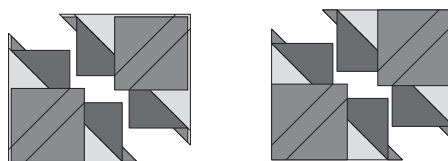

Steps 5 & 6 - Position and Mark

Step 7 - Stitch on both of the drawn lines, then cut between the lines of stitching on the center diagonal, as seen below.

Step 8 - Press seams toward the smaller triangles (I do this no matter which is dark or light).

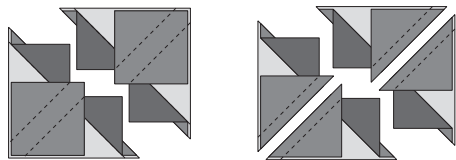

Step 7 - Stitch and Cut

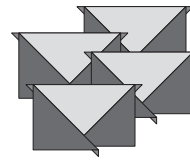

Step 8 - Press

Your oversized units will now be trimmed with the **Pint Size Wing Clipper®**. Consult the chart for the proper tool section to use for trimming.

Trim Down Process - Right Handed Quilters

Step 9 - Position your oversized units horizontally on your cutting mat with the long edge of the center triangle furthest away from you (in the “valley” position).

Step 10 - Align the appropriate diagonal guidelines of the **Pint Size Wing Clipper®** with the sewn seams of the Flying Geese unit. You’ll automatically be centering the tool over your pieced unit.

Step 11 - Trim up the right side and across the top of the **Pint Size Wing Clipper®**, then rotate the Flying Geese unit 180°.

Step 12 - Reposition the **Pint Size Wing Clipper®** to align clean-up guidelines with the previously trimmed raw edges and the “X” at the top with the intersection of the seams. Again, be sure to have the proper cut sizes aligned for your particular project.

Step 13 - Trim again, up the right side and across the top. Each unit will now be precisely sized with all the seams properly positioned for perfect points every time.

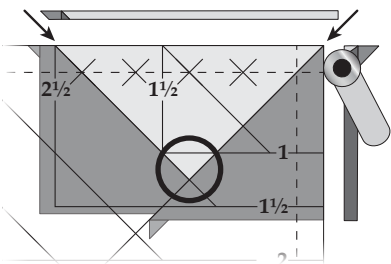

Step 9 - Position, Align, and Trim

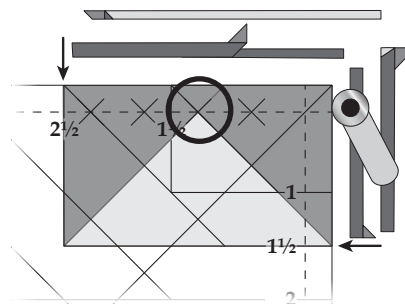

Steps 12 & 13 - Reposition and Trim Again

Trim Down Process - Left Handed Quilters

Step 9 - Position your oversized units vertically on your cutting mat with the long edge of the center triangle on the left as shown (with “the geese going east”).

Step 10 - Align the appropriate diagonal guidelines of the **Pint Size Wing Clipper®** with the sewn seams of the Flying Geese unit. You’ll automatically be centering the tool over your pieced unit.

Step 11 - Trim up the left side and across the top of the **Pint Size Wing Clipper®**, then rotate the Flying Geese unit 180°.

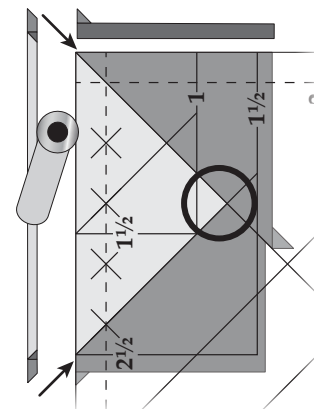

**Steps 9-11 -
Position, Align, and Trim
Pint Size Wing Clipper®, pg. 3**

Step 12 - Reposition the Pint Size Wing Clipper® to align cleanup guidelines with the previously trimmed raw edges and the “X” at the left with the intersection of the seams. Again be sure to have the proper cut sizes aligned for your particular project.

Step 13 - Trim again, up the left side and across the top. Each unit will now be precisely sized with all the seams properly positioned for perfect points every time.

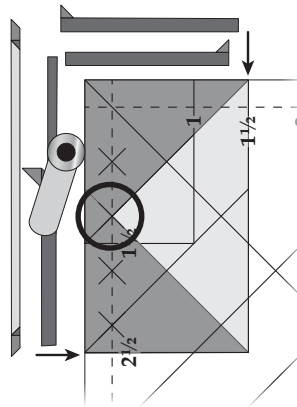

**Steps 12 & 13 -
Reposition and Trim Again**