

90 mm

# Waterfall Pumps

## Instruction Manual

### SP SERIES SUBMERSIBLE PUMP

### SP-600 / SP-650



KLB Engineering.  
 Info line + 27 11 668 1923/4  
[www.klbengineering.com](http://www.klbengineering.com)

180 mm

Thanks for buying our pump. To ensure you use the pump safely and correctly, please carefully read through this instruction manual.

#### Pump Features

1. Super small design, ideal for moving volumes of water through small pond or water feature systems.
2. Vortex impeller for efficiency & energy saving.
3. Ceramic bearing & shaft providing longer pump life-span with Better corrosion resistance.
4. Simple 'no-tool' clip together design making it easy to disassemble/assemble quickly & conveniently
5. Built-in thermal overload switch with a self-resetting feature to ensure safe operation of the pump in strenuous conditions.
6. Unique outer housing cage design to alleviate blockages

#### Safety Information

Please operate this pump within the specified voltage and frequency rating as indicated on the pump rating label & manual instructions.

A 10mA residual current device must be fitted to the mains supply to keep safe.  
 Before cleaning or moving the pump, always disconnect it from its power sources.

The power cord is not replaceable. If the power cord or the plug is damaged, stop using the pump immediately.  
 Return the pump to the place of purchase for disposal.  
 DO NOT attempt to change plug or shorten the power supply cord by yourself. Keep the plug dry at all times. DO NOT lift or pull the pump by its power cord to move.

We recommend fitting a lifting cord to the handle of the pump for moving and maintenance actions.

DO NOT operate or leave the pump in freezing conditions.  
 If you live in a hard water area (water with high levels of calcium or limescale content), the pump, rotor assembly & inside of motor should be cleaned at regular intervals (see MAINTENANCE & CLEANING section).

#### Thermal Overload Protection

This pump is configured with thermal overload 'self-reset' protection. If the motor overheats, the switch will activate & cut off the power automatically. If this occurs, switch the pump off at its main power supply. Then check for the pump for debris blocking the inlet/outlet of the pump or the impellor.

Remove the obstruction, check the electric cable & wait for 15 minutes. When the motor has cooled down, the thermal overload switch on the pump will reset. You can then switch on the pump (at the power source) & it should start to work again.

Monitor the pump for a few minutes to ensure it does not cut off again. If the problem persists, return the pump to your supplier for diagnosis & advice.

#### Operation

1. Place the pump in the water near the bottom of the feature.
2. Measure and then Connect the water features tube to the outlet of the pump. Make sure there are no kinks in the tube.
3. Set the flow volume by hand initially to the maximum.
4. Fully submerge the pump into the water of the water feature and check it has a stable positions before suctioning the feet to the side/ bottom of the water feature reserve water tank
5. Turn the pump on, adjust the flow as required and check for any splash wastage of water.

#### Maintenance & Cleaning

##### WARNING

Disassembling the motor or any alteration to the power cord will void the warranty as the power cord is moulded into the casing and is not replaceable.

In case of damage to the cord, the whole pump will need to be replaced.

##### Regular Care

This pump is lubricant free & requires minimal maintenance. to keep the pump operating in the best condition with a long life-span. Simply follow these easy maintenance steps below periodically or if the pump stops working.

1. Disconnect the pump from the power sources & move it to a dry safe place.
2. Unclip the base pre-filter so that you can take out the pump Impeller to clean it & the housing.
3. On the pump, release the impeller cover guard & take out the vortex rotor assembly from pump body.
4. Clean all the parts with running water.
5. After cleaning, assemble the rotor carefully and return to the pump body making sure that the 2 locating holes on the impellor cover & the 2 locating pins on main body fitted together snugly before inserting the Impellor and installing the rotor assembly properly.
6. Turn the impeller gently to check that it is secure & correctly inserted so that it can turn smoothly. At this point make sure that the sealing ring is in its place.
7. Return the impellor cover to the pump body.
8. Then reconnect the power & return the pump to its place.

\*\*\* Clean the pump at least once a month. More frequent cleaning might be needed depending on the water condition.

### Winter Care

If you pond freezes over during winter, the pump should be removed from the pond, cleaned & stored properly.

We recommend storing the pump in a bucket of water. This is to prevent the bearings from drying out and potentially seizing.

This is especially important if you have been using your pump in a hard water area. The water will help dissolve the calcium or lime-scale deposits.

You can add mild acid solution, such as vinegar or lemon juice, to the water to be more effective.

### Special Care for Hard Water

If you live in a hard water area (water with high levels of calcium or lime-scale content), the pump, rotor assembly and steel should be cleaned at regular intervals.

The cleaning interval required will vary depending on the hardness of your water. Inspect the pump periodically for signs of calcium buildup.

To clean off calcium or lime-scale deposits, a small nylon bristled brush (such as a tooth brush) may be used on the body of the pump and it's parts. Dismantle the pump as described in the maintenance section above and remove the rotor.

Clean the lime-scale deposits from the rotor with fresh clean water only. DO NOT use soap or any abrasive materials. These can damage the pump and the water quality of your pond.

If there are excessive calcium deposits that have built up, the thermal overload protection may be activated. This can be avoided with regular care & cleaning of the pump & your pond.

### Guarantee & Warranty

Waterfall pumps are guaranteed against defective material and workmanship for a period of 24 months from original date of purchase by the end user/installer.

The guarantee does not cover improper use, abuse, negligence or accidental damage to the pump, or its parts.

Pumping dirt will shorten the life span of the pump and can cause failure due to excessive wear and tear or over heating - this is not covered by the guarantee.

As the Impellor & Shaft are wearing components they are not covered by the Guarantee.

As the Shaft is made from ceramic materials it is breakable if mishandled. A broken shaft is not covered by this Guaranty.

The manufactures and distributors shall not be liable for any consequential damage whatsoever from the sale, misuse or use of this pump.

The manufacture and distributor of Waterfall pumps shall not be liable for any loss of fish, plants, animals or livestock or for any disruption of use for any reason whatsoever.

# SP SERIES PUMP

## Pump Structure Diagram

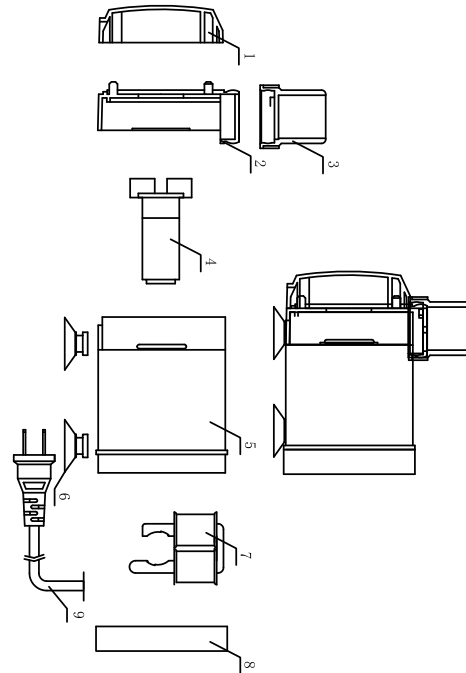

1. Pump Cover 2. Impeller Cover 3. Outlet 4. Impeller 5. Pump Body
6. Rubber Suction Cup 7. Rotor 8. Casing 9. Power Cord



Do not dispose of electrical appliances as unsorted municipal waste, rather use separate collection facilities provided for such waste. Contact you local government for information regarding the collection systems available. If electrical appliances are disposed of in landfills or dumps, hazardous substances can leak into the groundwater and get into the food chain, damaging your health & well-being.

**CAUTION:** Always unplugged the pump from the electrical supply before any handling of the pump or accessories. Never lift the pump from the pond by the electrical cable. If the electrical cable is damaged it can not be replaced.

*Waterfall*  
Pumps

# SP SERIES PUMP

## Performances Curve

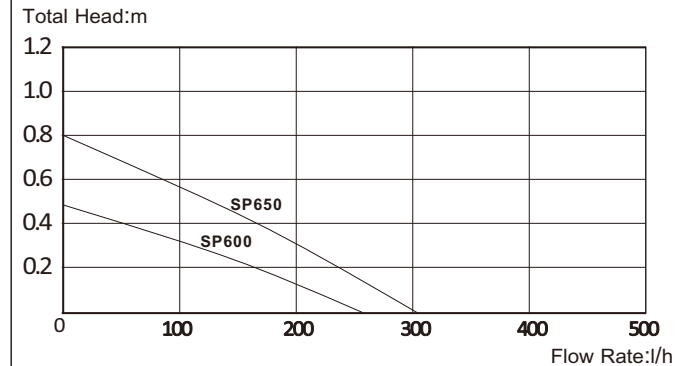

## Technical Data

MODEL	POWER	H.max (hight)	Q.max (flow)
SP600	5W	0.45M	260L/H
SP650	5W	0.8M	300L/H

## Distributed by

**KLB Engineering**

Info line + 27 11 668 1923/4  
[www.klbengineering.com](http://www.klbengineering.com)