

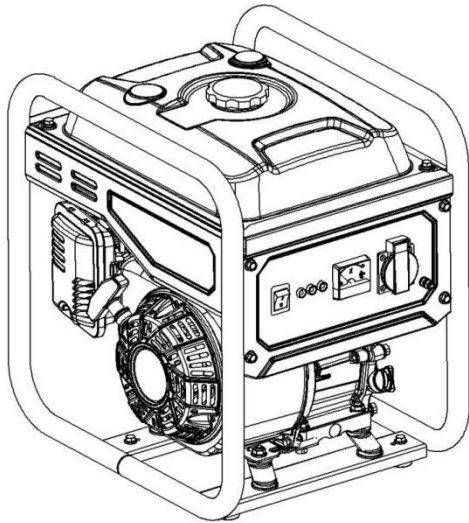

RED RHINO
PRODUCTS

INVERTER GENERATOR USER'S MANUAL



Thank you for choosing our inverter generator.

This manual covers the right operation and maintenance. Before operating, please read it carefully, then you'll gain good rewards.

All technical data and drawings in this manual are consistent with the latest products while publication. As a result of revisions and other changes, the contents of this manual may be slightly different from the actual situation.

We reserves the right to make changes at any time, without notice and without incurring any obligation, please understand.

The copyright of this instruction manual belongs to us. No reproduction is allowed without the written consent of us. All rights reserved.

This manual is a permanent part of the generator set and will be resold together with the generator set if it is resold.

Safety Warning

The personal and property safety of you and others is very important. Please read carefully the extremely important safety warnings we have written in the manual and the label of the generator set.

Safety warnings can alert you to potential dangers that may harm you and others.

There are one of these three symbols : "Danger", "Warning", "Notice" in front of safety warning. Details as below:



If you do not follow the instructions, your life will be in danger or you will be seriously injured.



If you do not follow the instructions, your life will be in danger or you will be seriously injured.



If you do not follow the instructions, you will be slightly injured.

If you do not follow the instructions, your generator set and other property may will be damaged.

Content

Safety Warning.....	2
Content.....	3
1. Safety Instruction.....	5
1.1 Safety Specification.....	5
1.2 Special Request.....	7
2. Safety Warning Label.....	8
3.Components Identification.....	9
3.1 Components Feature.....	9
3.2 Control Panel.....	10
3.3 Type and Serial Number.....	11
4. Control System.....	12
4.1 Engine Oil Alerting System(RED).....	12
4.2 Overload Indicating Light(RED).....	12
4.3 AC Indicating Light(GREEN).....	13
4.4 Ignition Switch.....	13
4.5 Choke Valve Handle.....	14
5. Preparation.....	15
5.1 Fuel Oil.....	15
5.2 Engine Oil.....	16
5.3 Recoil Starter.....	17
5.4 Fuel Tap.....	17
5.5 Ground Terminal.....	18
6. Generator Use.....	18
6.1 Connect to House Power Supply.....	18
6.2 Generator Grounded.....	19
6.3 AC Output.....	20
6.4 Used in High Altitude Areas.....	22

7. Starting the Generator.....	23
7.1 Recoil Start.....	23
8. Stopping the Generator.....	23
9. Maintenance.....	24
9.1 Replace Engine Oil.....	25
9.2 Air Filter Maintenance.....	26
9.3 Spark Plug.....	28
10. Storing.....	29
11. Trouble Shooting.....	30
12. Circuit Diagram.....	31
13. Technical Specifications.....	32

1. Safety Instruction

1.1 Safety Specification

Please read and be well known about the manual before operating.

Familiarity with the safe operating procedures of generators can help you avoid accidents.

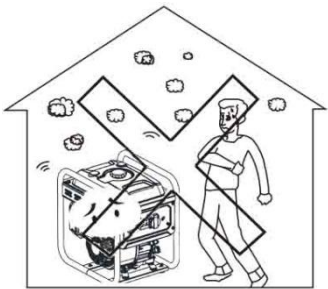
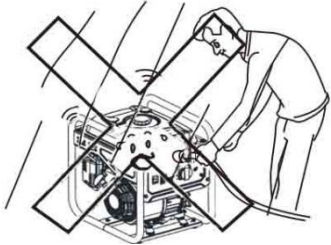
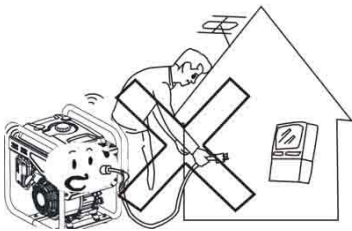
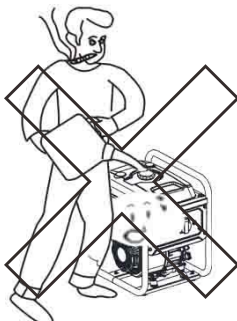
	
<p>Don't use it indoor.</p>	<p>Don't use it in damp environment.</p>
	
<p>Do not connect directly to household appliances.</p>	<p>Don't smoke while adding fuel oil.</p>

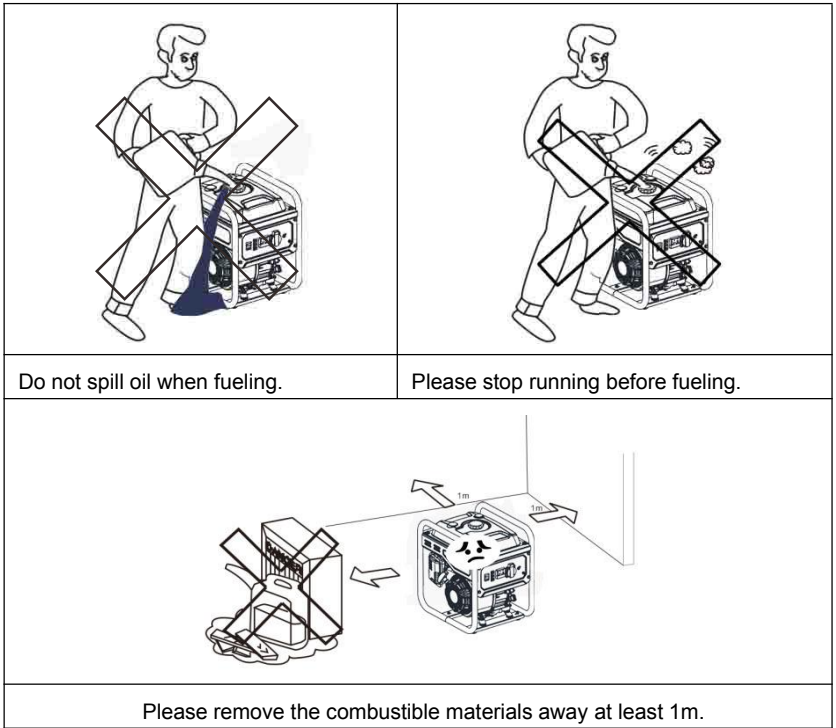







1.2 Special Request

- Electrical equipment includes unexposed wires and plugs.
- The protecting breaker should be matched with generator. The application parameters and performance should be totally matched if changing.
- Well grounded before using.
- If need extension wire, it must meet the requests as below:
4mm², length no more than 100m.

2. Safety Warning Label

Please read the manual carefully before using.

Safety warning label

 <ul style="list-style-type: none">• Check that there is not any fuel spilling or fuel leakage.• Not to refuel when operating.	 <p>Exhaust gas is poisonous. Do not operate in an unventilated area [Carbon monoxide (CO) danger].</p>	WARNING 
 <ul style="list-style-type: none">• Let the generator cool before storing.• Gasoline is explosive and flammable, please use the generator outdoor.	 <ul style="list-style-type: none">• Do not expose the generator to rain, moisture or snow.	
 <ul style="list-style-type: none">• Do not connect to a building's electrical system.	 <p>Read the operator's instruction manual.</p>	

 WARNING	
	<p>Hot exhaust can burn you .Stay away if engine has been running.</p> 

3.Components Identification

3.1 Components Feature

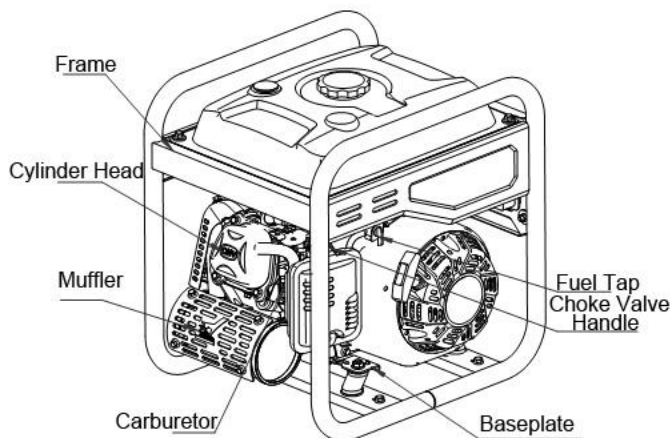
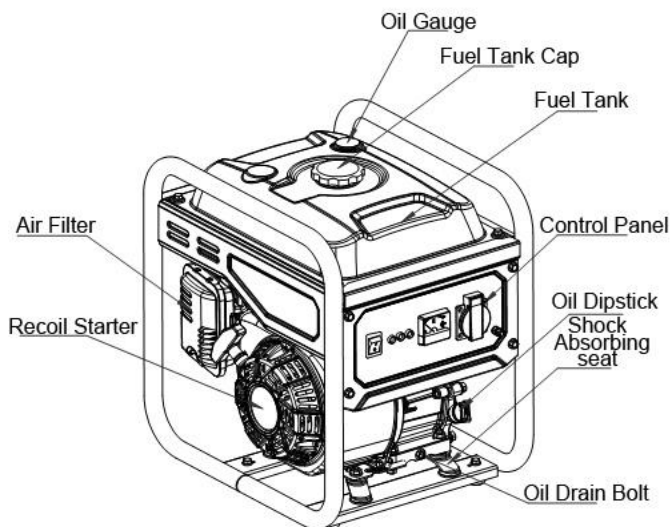

3.2 Control Panel

(Factory will adjust the panel according to different configuration. Please note that subject to change without prior notice.)

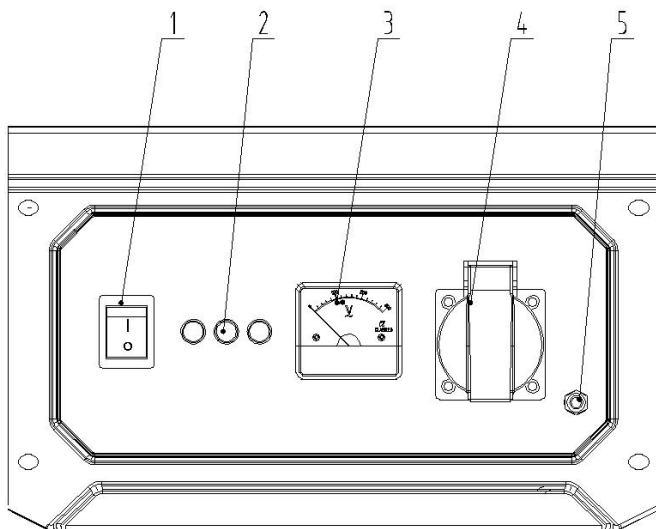

1	Ignition switch
2	Indicating light
3	Voltmeter

4	AC socket
5	Ground terminal

3.3 Type and Serial Number

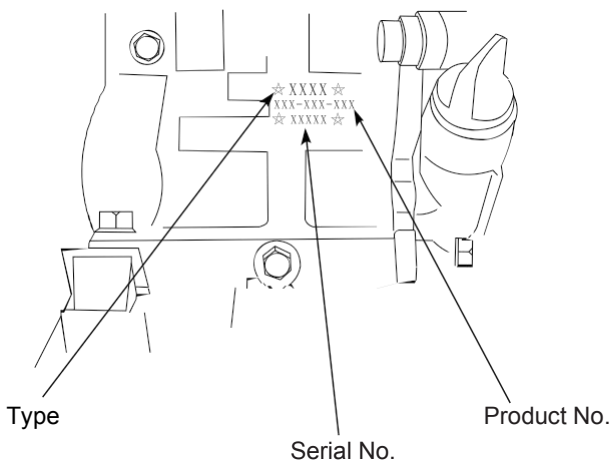

4. Control System

4.1 Engine Oil Alerting System(RED)

The engine oil protection system will stop the engine automatically, and the engine oil indicating lights, while the oil in crankcase is under safe line; Fill the engine oil to the oil level, it can be restart again.

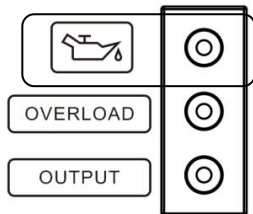

If the engine oil alerting light flashes for few seconds, it means the oil capacity is insufficient. Refill the oil and restart the engine.

4.2 Overload Indicating Light(RED)

When the overload indicating light is on, the generator detects that the output of the phase-side electrical equipment has been overloaded,

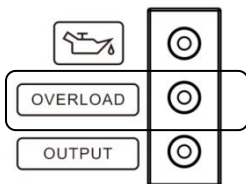

causing the converter to overheat or the AC voltage to rise. Then the AC protector works and stops the generator to protect the generator and the equipment which connects with it. The AC indicating light(GREEN) is off, but overload indicating light (RED)is on,engine will not stop working.

While the overload light is on, and the generator has no output, please take following measures:

1. Turn off the connected electrical equipment and stop engine.
2. Reduce the total power rate of connected electrical equipment

within the rated output range.

3. Check whether the cool air inlet is blocked by foreign matters and whether the relevant control parts are abnormal. If there is any problem, remove it immediately.

4. Restart the engine after checking.

Notice: When using the electrical equipment with high starting current(like compressor and sinking pump...), the overload indicating light may will flash for few seconds. But this doesn't belongs to troubles as aforementioned.

4.3 AC Indicating Light(GREEN)

The AC indicating light will be on while the engine starts and keep normal output.

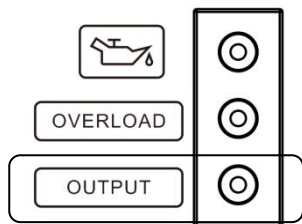

4.4 Ignition Switch

When the ignition switch is set to the "ON" position, the generator can start and operate normally; when the ignition switch is set to the "OFF" position, the secondary coil of the ignition coil of the generator set is connected with the ground, and the spark plug will not ignite. Turn the switch to the "OFF" position during shutdown.



4.5 Choke Valve Handle

When the choke valve handle is in the "ON" position, the carburetor's choke is in the open state, so as to ensure that the carburetor can have enough air intake to ensure the operation of the generator. When the engine is running, and when restart tge hot engine or when the ambient temperature is high, the choke valve handle should be placed in the "ON" position; When the choke valve handle is in the "OFF" position, the carburetor's choke is in the close state. At this time, the intake of carburetor decreases, and the concentration of oil gas mixture entering engine combustion chamber increases. When the ambient temperature is low, it is necessary to put the choke handle in "OFF" position to increase the starting ability of the engine.



5. Preparation

5.1 Fuel Oil



- Fuel oil is flammable and toxic. Please read the safety instruction carefully before refueling.(See Page 7 for details.)
- Do not fill the tank with too much oil, or the oil will overflow when the tank gets warm.
- After refueling, make sure the fuel tank cover is tightened.

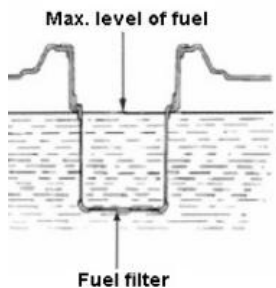
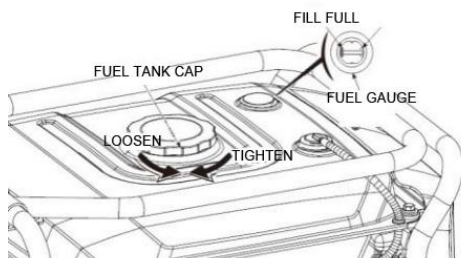

- To avoid damage the plastic outer case, please wipe off residual gasoline with a clean, soft cloth after refueling.
- You must use unleaded gasoline. The leaded one would damage the internal parts of the engine.

Suggestion: unleaded gasoline

Fuel oil tank capacity: 7.5L

5.2 Fuel Oil



The generator is not injected with engine oil when leaving the factory. Please do not start it before injecting enough engine oil.

The oil capacity is 0.55L.

Use the oil that meets or exceeds the service level requirements of SG and FG. The engine oil grade SG and FG will be marked outside the container of oil. SAE 10W-30 is a recommended engine oil for generator sets at common temperatures. When the average temperature of your area is within the range shown in the chart, other viscosity engine oil can be used.

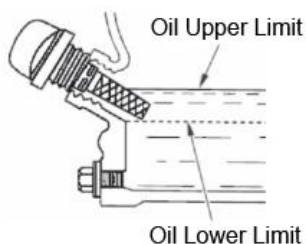
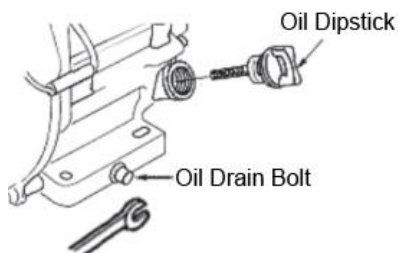
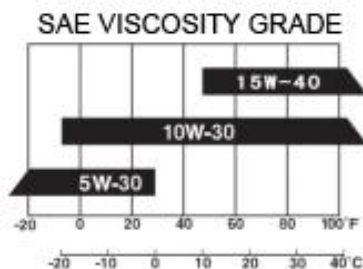

5.3 Recoil Starter

Pull the starter handle up gently until resistance is felt, then pull it out suddenly.



After starting, please do not let the starting handle spring back suddenly, but gently put the handle back.

Recoil Starter

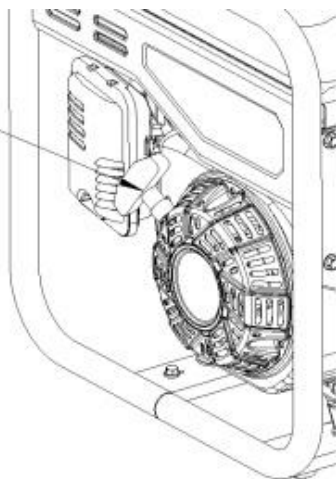

5.4 Fuel Tap

Fuel tap is a device that controls the flow of fuel from the tank to the carburetor. Please make sure it is on position of "OFF" after stop working.

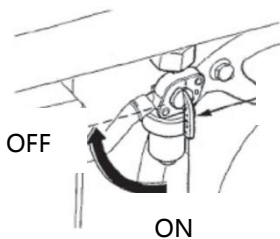

Fuel Tap

5.5 Ground Terminal

2. the grounding terminal is connected to the ground wire to prevent electric shock. When the electrical equipment is grounded, the generator must be grounded.

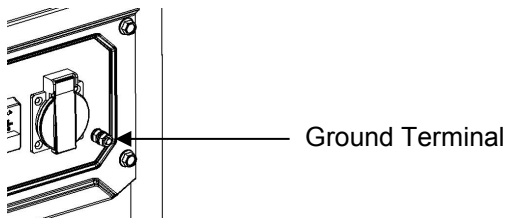

3. Ground terminal is a special terminal used to ground the entire generator.

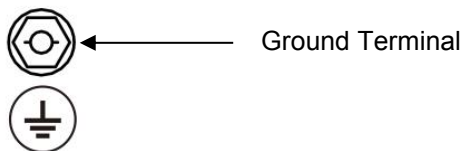

6. Generator Use

- Applicable temperature: $-5^{\circ}\text{C} \sim 40^{\circ}\text{C}$
- Applicable humidity : below 95%
- Applicable altitude: below 1000m (Lower power should be used in the area above 1000m or contact the dealer to adjust the carburetor.)

6.1 Connect to House Power Supply



While connecting the generator as a house power supply, it should be operated by a specialist electrician or someone familiar with electricity.

Please check the safety of connecting while connect load with generator. It may would be damaged, burned or fired if connected incorrectly.

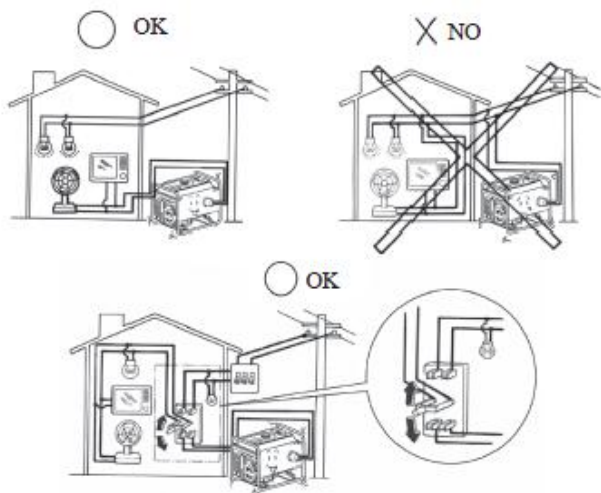

6.2 Generator Grounded

In order to prevent electrical appliances from being damaged by electric shock or the wrong use of electricity, it is recommended to ground the generator with good conductors covered with insulation.

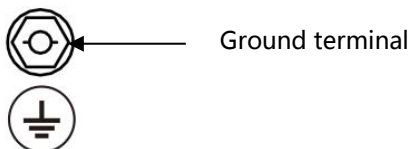

6.3 AC Output

Before starting the generator, please confirm:







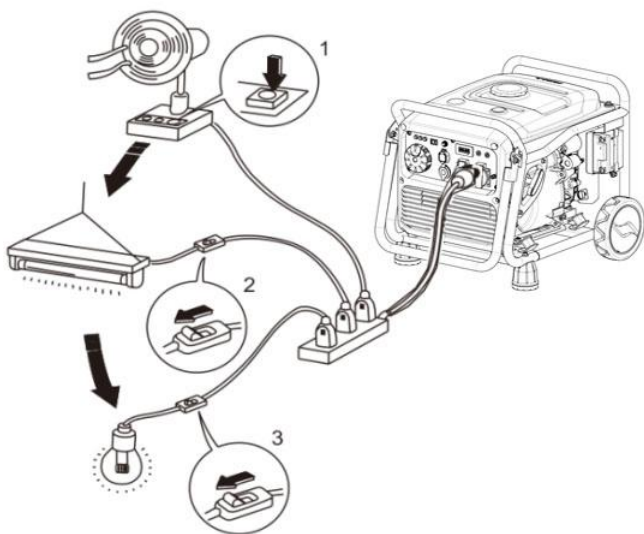

The total power of the load appliances (the sum of the resistive, capacitive and inductive loads) shall not exceed the rated power of the generator.



Overuse can cause a generator to shut down or significantly shorten its life. If the generator set is connected with several load or electric equipment, please remember: First switch on the starting load with the highest, then in turn, and finally switch on the starting current with the lowest.



Generally speaking, capacitive and inductive loads, especially motor drives, produce a large starting current during starting. The following table is for your reference when connecting these electrical appliances to the generator set.

Type	Power		Typical Device	Example		
	Max.	Rated		Device	Max.	Rated
<ul style="list-style-type: none"> ● Lamp ● Heating devices 	*1	*1	100W  lamp  TV	100W  lamp	100VA (W)	100VA (W)
<ul style="list-style-type: none"> ● Fluorescent lamp 	*2	*1.5	40W  Fluorescent lamp	40W  Fluorescent lamp	80VA (W)	60VA (W)
<ul style="list-style-type: none"> ● Electrical devices 	*3-5	*2	 Fridge 150W  Fan	150W  Fridge	450-750VA (W)	300VA (W)

6.4 Used in High Altitude Areas

At high altitudes, a standard carburetor will make the gasoline engine mixture too strong, reduce the output power and increase the fuel consumption rate. The performance of a gasoline engine can be improved by replacing the carburetor with a smaller main nozzle or by adjusting the adjusting screw. If you always use the generator at high altitudes among 1000m from sea level, you can come to our authorized dealer to replace a carburetor. Otherwise, the load power should be reduced by using the generator.

Even with the right carburetor, each 300m rise in altitude reduces the power of a gasoline engine by about 3.5%. This decline would have been greater if the carburetor had not been replaced properly.



If the carburetor suitable for high-altitude use is equipped with the gasoline engine suitable for low-altitude use, the thin mixture will cause the output power of the gasoline engine to drop, overheat and even cause serious damage.

7. Starting the Generator

7.1 Recoil Start

- 1) Remove all loads from the output.
- 2) Put Ignition Switch in the “ON” position.
- 3) Put Fuel Tap in the “ON” position.
- 4) Put the AC circuit Protector in the “OFF” position (if have).
- 5) Put the Choke Valve Handle in the “OFF” position.



Do not close the choke valve when the gasoline engine is started in hot state.

- 6) Pull the starter handle up gently until you feel resistance and pull it out quickly.
- 7) When the generator is started, slowly place the choke valve handle in the “ON” position.
- 8) Put the AC circuit protector in “ON” position before using the electrical load (if have).

8. Stopping the Generator

- 1) Turn off AC circuit protector (if have).
- 2) Turn off the ignition switch of generator.
- 3) Turn off the fuel tap.
- 4) Disconnect all electrical equipment.



To stop the generator in an emergency, put the generator switch in the "OFF" position.

9. Maintenance

Good maintenance is the best guarantee for safe, economical and zero fault operation, also contribute to environment protection.

In order to keep the engine in good condition, you must check and maintain it regularly. Please follow the schedule below.

Item		Maintenance period			
		Each use	First month or 20 hrs	Every 3 months or 50 hrs	Every year
Engine oil	Check-Refill	√			
	Replace		√	√	
Gearbox gear oil (If any)	Check oil level	√			
	Replace		√	√	
Air filter element	Check	√			
	Clean		√		
	Replace			√	
Precipitation cup (if any)	Clean				√
Spark plug	Check-Adjust				√*
Spark arrester	Clean		√	√	
Idle (if any)**	Check-Adjust				√
Fuel tank & filter**	Clean				√
Fuel oil pipe	Check	Every 2 years (Please replace it if necessary.)			
Cylinder head, Piston	Remove carbon deposition**	Displacement < 225cc , every 125 hrs; Displacement ≥ 225cc , every 250 hrs.			
* These items should be replaced if necessary.					
** These items should be maintained by our authorized dealers unless the user has the appropriate tools and repair capacity.					

- The engine oil should be replaced every 10 hours if working frequently at high temperatures or loads.
- The air filter element should be cleaned every 10 hours if working frequently at dusty or bad environment. If necessary, please replace it every 25 hours.

 **NOTICE**

- Spot inspection cycle and time, should be the first to carry out maintenance.
- If the maintenance cycle time has passed, the maintenance should be carried out as soon as possible according to the above table.

 **WARNING**

Please stop the generator before any maintenance. Place it in a horizontal position. To prevent engine starting, separate the spark plug cap from the spark plug.

Please do not use it indoors or in places with poor ventilation such as tunnels and caves. Make sure the working area is well ventilated. Exhaust from engines contains the toxic gas carbon monoxide, which can cause shock, loss of consciousness and even death when inhaled.

9.1 Replace Engine Oil

Discharging the oil after starting the engine ensures a quick and clean process.

- ① Remove the oil gauge. Screw open oil bolt to drain oil.
- ② Install the drain bolt and tighten it.
- ③ Fill oil and check oil level (Please read the preparation for oil type

selection and filling capacity. See page 15 for details).

④ Install the oil gauge.



Prolonged and frequent exposure to oil can lead to skin cancer. While this is not a given, it is still recommended that you use soap and water to immediately and thoroughly wash any skin that has been exposed to oil.

From an environmental point of view, please properly handle the waste oil produced after use. We strongly recommend that you put the oil in a sealed container and take it to your local service station or oil recycling center. Please remember: don't throw it in the trash or dump it on the ground or in a ditch.

9.2 Air Filter Maintenance

Dirty air filters will affect the flow of air into carburetors. To prevent carburetor breakdown, air filters should be regularly maintained. If it is used in dusty environment, it should be maintained more frequently.



Cleaning the filter element with gasoline or flammable solvents may cause fire or explosion. Please use soapy water or non-flammable solvent to clean the filter element.



It is strictly forbidden to start the generator without air filter, otherwise it

will lead to rapid wear and tear of the gasoline engine.

1) Open the locking bolt of the air filter cover and open the air filter cover. Check the filter element and ensure it's in good condition and clean.

2) If the foam filter is dirty, please clean it. Wash in hot water with household detergent or in non-flammable or high flash solvent. Then rinse with clean water and squeeze. Then drop a few drops of oil and squeeze evenly.

3) Fill in the filter element and cover the air filter cover, then tighten the locking bolt..

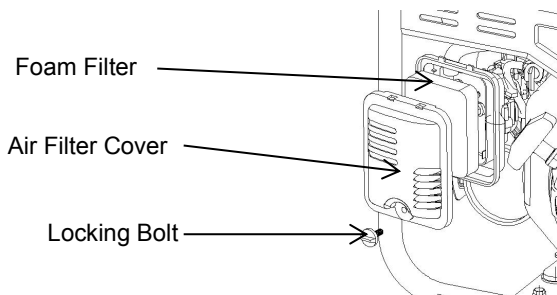

9.3 Spark Plug

Please replace the spark plug according to the original type: F7TC

- 1) Remove the spark plug cap.
- 2) Use the spark plug socket wrench to remove the spark plug.
- 3) Visually inspect whether the spark plug insulator is damaged.
Replace the spark plug if it is damaged.
- 4) Measure spark plug clearance with thickness gauge. Bend the side electrodes to adjust the clearance. The clearance shall be between 0.70 and 0.80mm.
- 5) Check that if the spark plug gasket is in good condition.
- 6) Install the spark plug, tighten it with the spark plug socket wrench, and press down the spark plug gasket. Cover the spark plug cap.

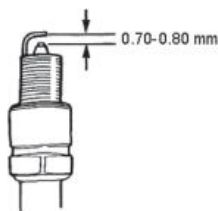

Please use spark plugs with appropriate calorific value.

10. Storing



To avoid combustion or misfire due to contact with high-temperature components of the generator, the generator must be cooled before packaging and storage.

If long-term storage is required, please make sure the storage area is clean and dry.

1) Drain fuel from the fuel tank.Clean the fuel filter, O - ring seal and precipitation cup after the assembly.Unscrew the carburetor drain bolt, drain the fuel from the carburetor entirely, then reinstall and tighten the carburetor drain bolt.



In ordinary circumstances, gasoline is flammable and explosive. Please discharge oil in well-ventilated condition after stop. No fireworks during oil discharge.

2) Unscrew the oil gauge and Oil drain bolt on the crankcase, and drain the oil in the crankcase. Then tighten the drain bolts, add new oil to the upper limit, and then install the oil gauge.

3) Remove the spark plug and pour a tablespoon of clean engine oil into the combustion chamber. Turn the crankshaft several times to distribute the oil. Reinstall the spark plugs.

4) Gently pull the starting handle until resistance is felt, leaving the inlet and exhaust doors close.

5)Place the generator set in a clean and dry area.

11. Trouble Shooting

Engine can't be started:

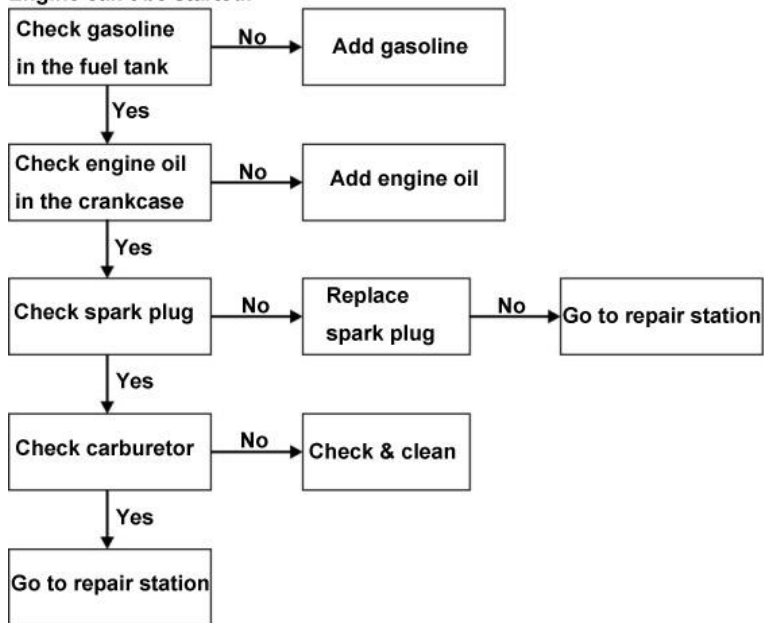

No voltage

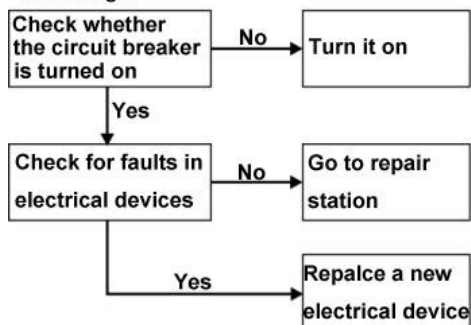

12. Circuit Diagram

(The factory will adjust according to the different configuration, subject to change without prior notice.)

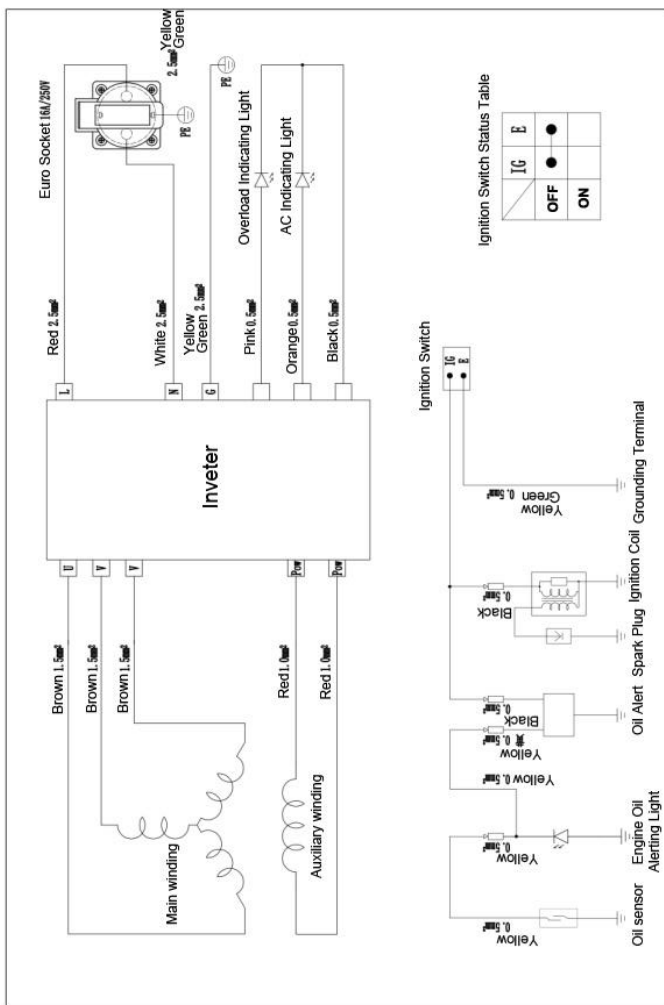

13. Technical Specifications

	Item	RGIV3750	RGIV4500i
Gasoline engine	Engine type	Single head,4-stroke,Air cooling OHV 25°	
	Displacement(cc)	208	223
	Ignition system	C.D.I	
	Starting type	Recoil start	
	Fuel tank capacity (L)	7.5L	
	Engine oil capacity(L)	0.55	
Generator set	Rated frequency(Hz)	50Hz/60Hz	
	Phase	Single	
	Rated voltage (V)	120/220V/230V/240V	
	Rated output power(kW)	3.2kW	3.5kW
	Max. output power (kW)	3.5kW	3.8kW
	THD without load	≤5%	
	Running time at rated power · h	≥3.5	
	Weight(kg)	25	
Dimensions(mm)	433×376×453		

