

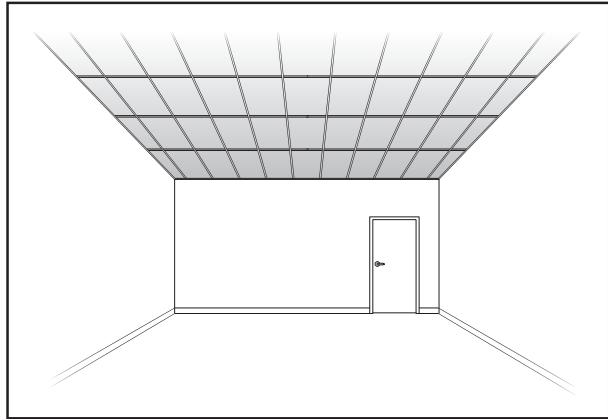

Ceiling Connex



www.ceilingconnex.com

Phone: 605-484-0875
 Email: info@ceilingconnex.com
 311 Lilly Ln
 Yankton, SD 57078

Follow Us:
facebook.com/ceilingconnex
pinterest.com/ceilingconnex

Made in the USA

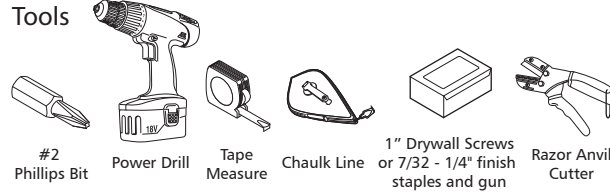

NOTE: When cutting the CeilingConnex Material, use either a sharp razor blade, Anvil Style Cutter or miter saw with a fine blade. Ripsaw blade is not acceptable.

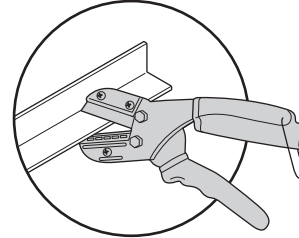

1. Mount Wall "L" Bracket Level 3/4" to 1" from the bottom of the Ceiling Joists.

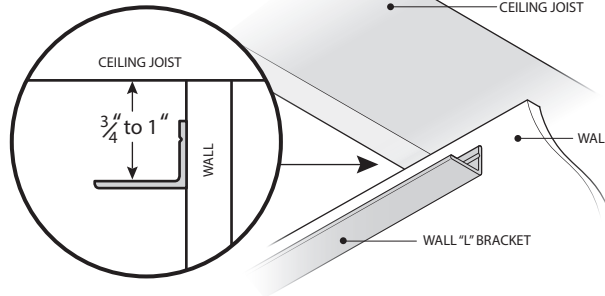

2. Install Wall "L" Bracket around perimeter of room as shown.

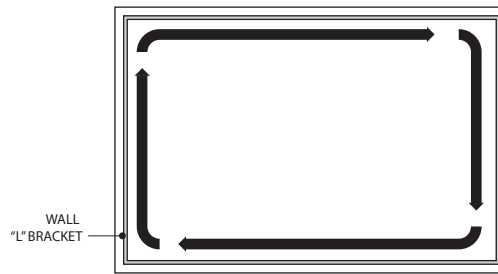

3. Fasten every 16" - 24". The corners can either be mitered to 45° or butt jointed.

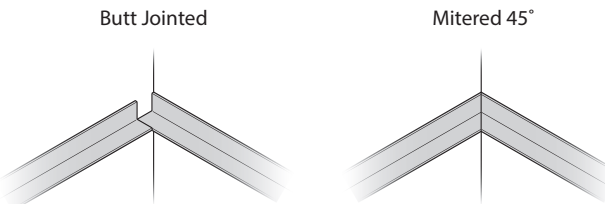

4. Layout Room

Optimal layout will provide equal sized boarder tiles on opposite walls. You can either have a full tile centered about the room or a room centered on the grid.

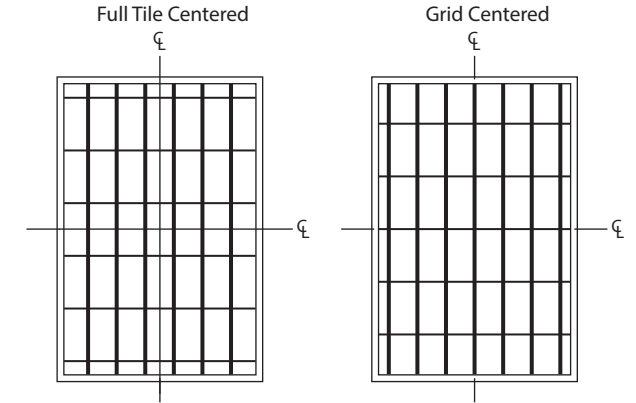

Which option you choose depends on lighting locations, room dimensions to maximize border tile size or personal preference.

Hang Main Runners perpendicular to ceiling joists or if surface mounted perpendicular to the rooms longest dimension.

Tile Centered Layout

Measure and mark 11.5" in each direction from centerline, this will be the inside dimension of your first two rows of Main Runners. Measure and mark every 24" till you have laid out the room.

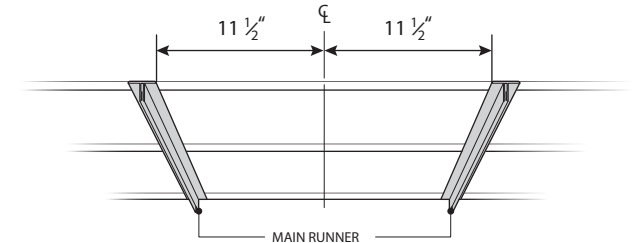

Grid Centered Layout

Center the first main runner on the center line of the room. Measure and mark every 24" till you have laid out the room.

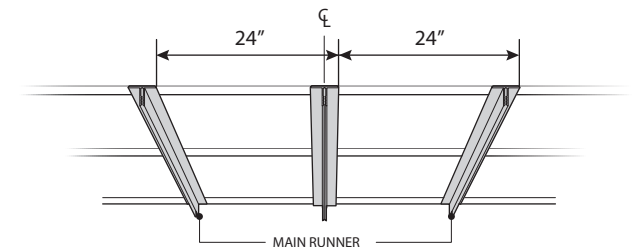

Mark remaining measurements using a chalk line.

NOTE: The 24" is from left edge to left edge or right edge to right edge - Not Left Edge to Right Edge.

5. Fastening Main Runners can be done with either a 1" sheetrock screw or for quicker installation an air stapler is sufficient.

Do not over tighten screws / staples as it can deform the plastic.

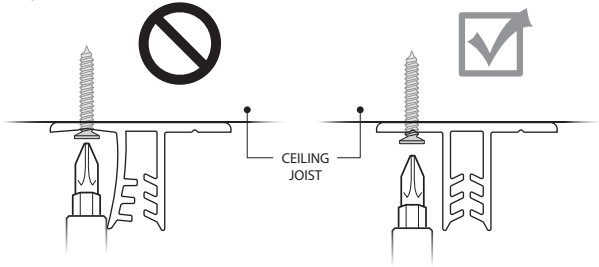

Fasten Main Runner every 16" - 24" on opposite sides to provide proper support for the tiles.

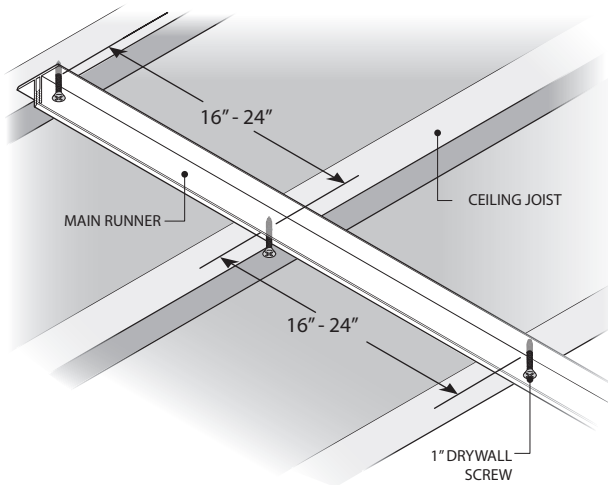

6. Once Main Runners have been installed, snap in a pair of Lower Support T's. DO NOT OVERLAP SEAMS.

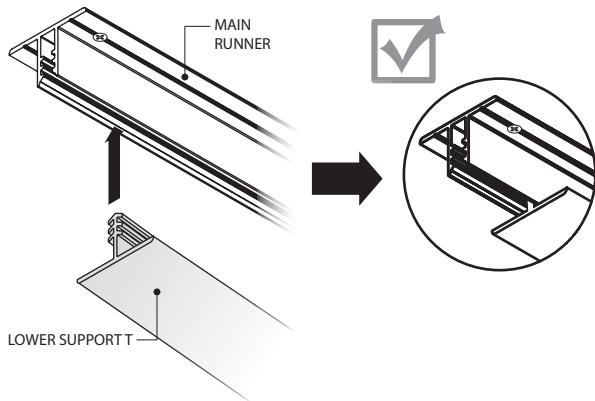

7. Cut Cross Tees to 23 3/4" utilizing Lower Support T's.

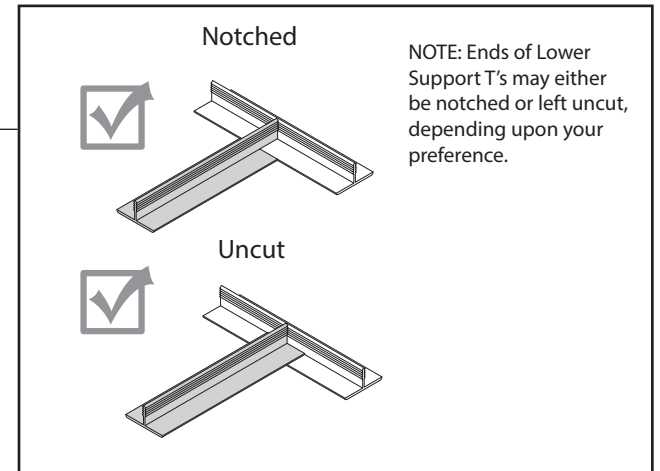
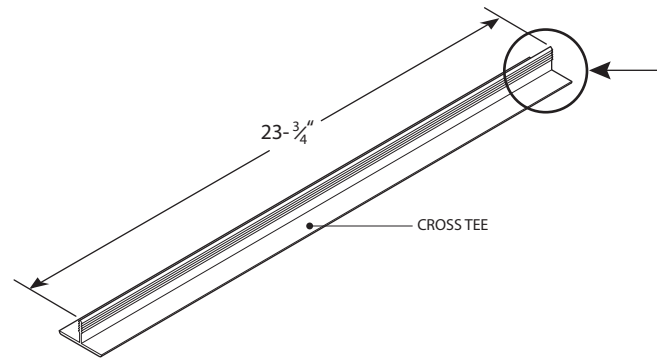

8. Slide in Tile, a Cross Tee and another Tile into the pair of tracks as shown. Repeat till room is complete.

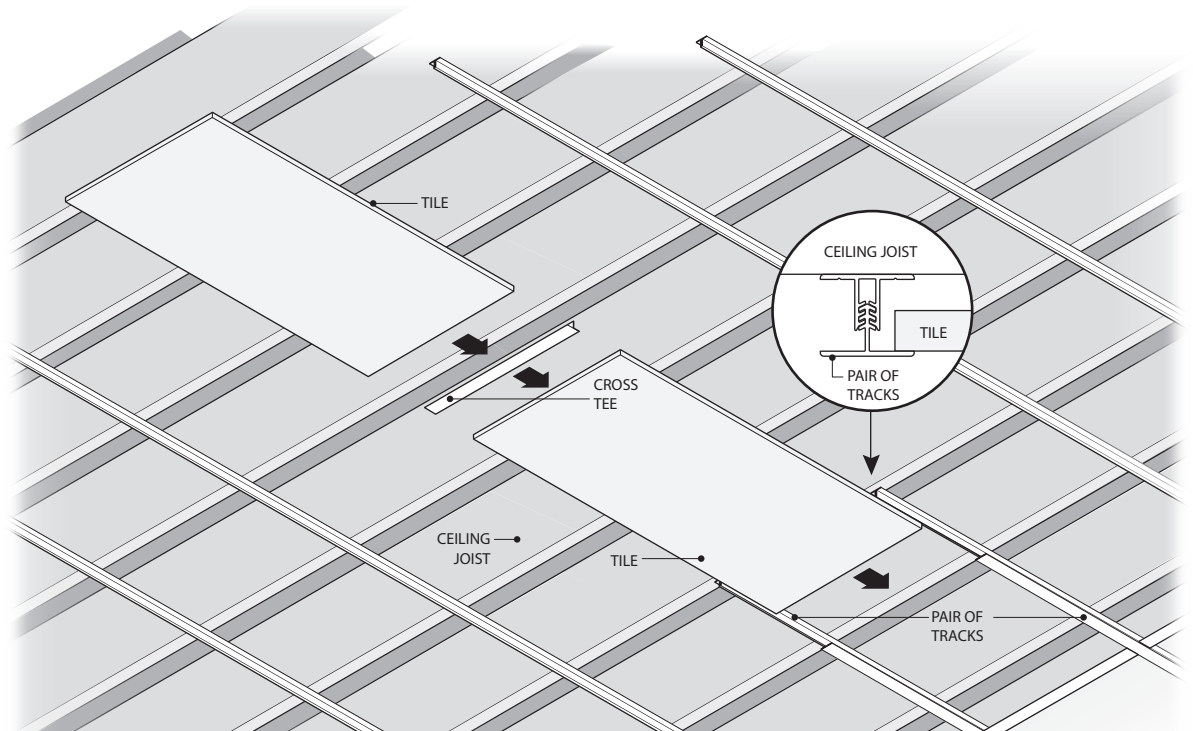

Every room is different. Please use this instruction manual as a guide but changes and modifications may be required depending on your room and selected ceiling tile.

If you have any questions or concerns, please call
 Phone: 605-484-0875
 or visit our website at:
www.ceilingconnex.com
 or e-mail us at at:
 Email: info@ceilingconnex.com