



This guide provides information and guidelines you need for the process of designing OPTOTRONIC Outdoor LED Drivers into a luminaire. This guide pays special attention to Ingress Protection capability of our drivers and how luminaire manufacturers can obtain maximum benefit out of it.

## Contents

<b>1 Introduction</b>	<b>2</b>
<b>2 Ordering Description</b>	<b>2</b>
<b>3 Features and Benefits</b>	<b>2</b>
<b>4 Driver Selection Criteria *(I<sub>out</sub>, v<sub>out</sub>)</b>	<b>3</b>
<b>5 Ingress Protection</b>	<b>4</b>
<b>6 Wiring</b>	<b>5</b>
6.1 Series Connection	5
6.2 Parallel	5
<b>7 EMI</b>	<b>6</b>
<b>8 Thermal Protection</b>	<b>6</b>
8.1 Driver Thermal Protection	6
8.2 LED Thermal Protection	7
<b>9 Surge</b>	<b>8-9</b>

## 1 Introduction

eldoLED continues to expand our product portfolio with innovative LED drivers for a wide variety of applications.

The OPTOTRONIC programmable dimmable family consists of highly efficient, constant current LED drivers for outdoor applications. One click programming through the OPTOTRONIC programmer allows OEMs to configure the output current with 1mA resolution. Also fully customizable by the OEM is the proprietary AstroDIM feature. AstroDIM is autonomous dimming for night-time power reduction based on an internal timer that can be set for an entire year.

These LED drivers are available in dimming to 10% or 1% (select models only) with built-in 0-10V or DALI dimming, enable direct integration and operation with standard dimmers, sensors, as well as energy and light management systems.

DALI enables bi-directional communications between the driver and the fixture-integrated component. DEXAL enables the same bi-directional communication, in addition to providing exact luminaire-specific data, including diagnostics, to light management systems.

The OPTOTRONIC Programmable Outdoor LED Drivers are IP66 rated suitable for outdoor/industrial applications like street lighting, parking and area lighting.

## 2 Ordering Description

OTi	50W	UNV	800C	2DIM+	P6	AUX
OT=OPTOTRONIC	Output Wattage	Input Voltage	Max. Output	2DIM=0-10V, AstroDIM	IP66	Vaux
OTi=OPTOTRONIC		UNV=120-277V	Current (mA)	2DIM+=0-10V, AstroDIM		(2DIM+ and
Intelligent		347-480+347-480V		DALI		DEXAL models only)
		HV=277-480V		DEXAL		

## 3 Features and Benefits

- OEM programmable with 1mA resolution
- Dimming down to 10% on 0-10V, DALI, and DEXAL models. Dimming down to 1% on select 2DIM+ 0-10V models.
- Integrated OEM programmable features include
  - AstroDIM (2DIM and 2DIM+ models only)
  - Constant lumen maintenance
  - LED thermal protection
  - Driver thermal protection
  - Auxiliary output (2DIM+ and DEXAL models only)
  - Dim to off (select 2DIM+ models)
- High levels of line transient protection for outdoor applications (6kV)
- IP66 Rated
- Available in:
  - Universal Input Voltage 120-277Vac 50/60Hz
  - 347-480Vac 50/60Hz
  - 277-480Vac 50/60Hz

For detailed description of these features, please refer to the family datasheet or specification sheet.

#### 4 Driver Selection Criteria \*(I\_output, v\_out)

To ensure optimum utilization of LED lighting, luminaire manufacturers need to pay special attention while selecting reliable LED drivers.

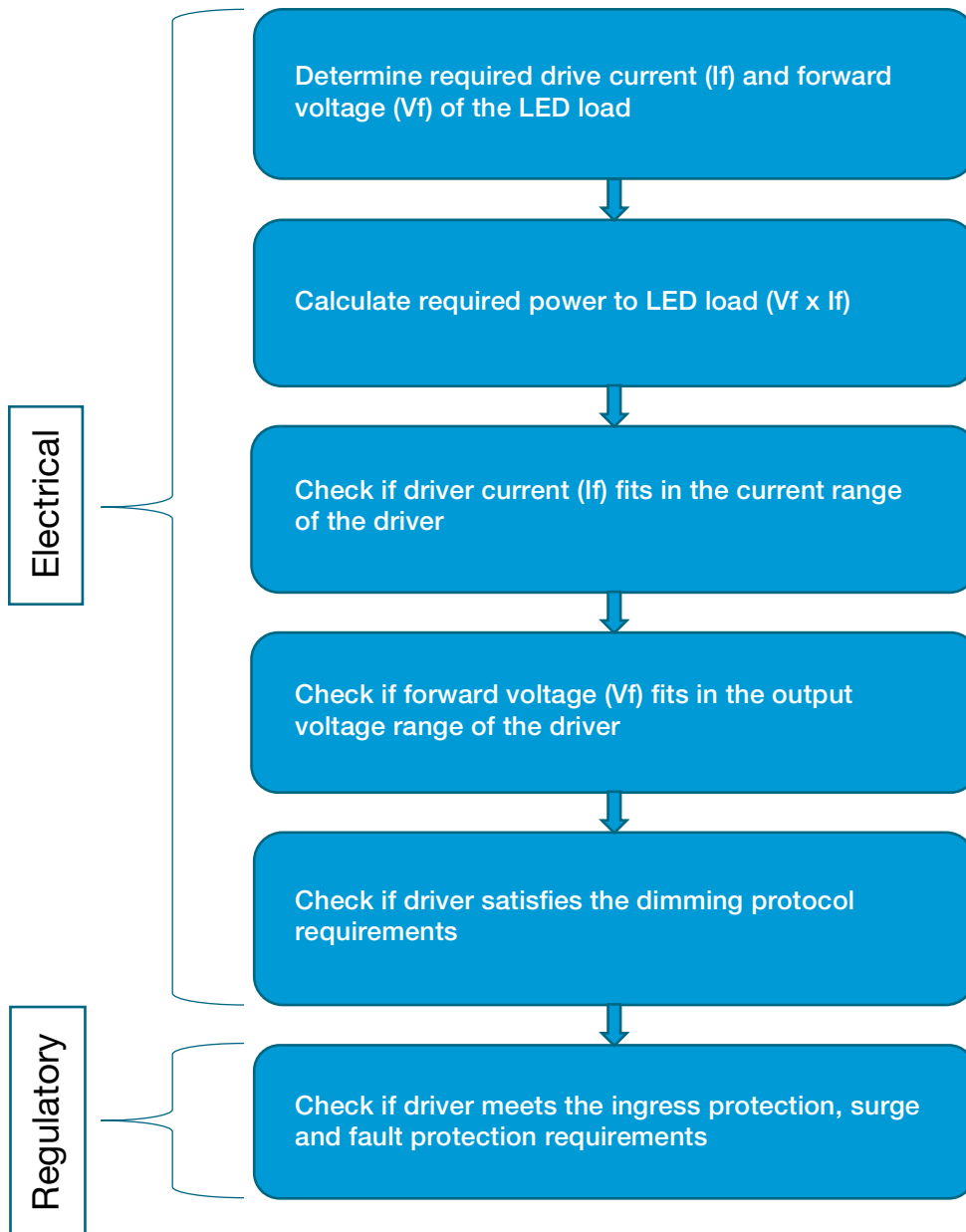

## 5 Ingress Protection

An Ingress Protection (IP) Rating is an enclosure rating which protects equipment against ingress of dirt or water, and protects a person from potential hazards within that enclosure.













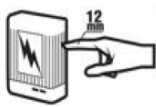

All OPTOTRONIC Outdoor LED Drivers are fully potted and IP66 rated. However, to ensure reliable operation, eldoLED recommends that the luminaire should be at least IP66 rated.

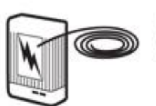
The degrees of protection are expressed as IP followed by two numbers, (e.g. IP64) where the numbers define the degree of protection. The first digit indicates the extent to which the equipment is protected against particles or to which persons are protected from enclosed hazards. The second digit indicates the extent of protection against water. (Standard details are referenced in the following table.)

First Digit: Describe solids requirements: The first digit indicates the level of protection that the enclosure provides against access to hazardous parts and the ingress of solid foreign objects.			Second Digit: Describe liquids requirements: Protection of the equipment inside the enclosure against harmful ingress of water.			
Level	Object Size	Effective Against	Level	Protected Against	Testing For	Protected Against
6	Dust Tight	No ingress of dust, complete protection against contact	6	Power water jets	Water projected by power jets (12.5mm) against the enclosure from any direction shall have no harmful effects	Test duration: 3 minutes. Water volume: 100 liters per minute. Pressure: 100KN/m2 at distance of 3m

As per the interactive IP rating chart below, water may enter the driver but only at non-hazardous levels. To ensure this, the enclosure used in the luminaire should have sufficient sealant to keep any water from entering the enclosure and the driver.

## IP (Ingress Protection) Ratings Guide

SOLIDS		WATER	
<b>1</b>	 Protected against a solid object greater than 50 mm such as a hand.	<b>1</b>	 Protected against vertically falling drops of water. Limited ingress permitted.
<b>2</b>	 Protected against a solid object greater than 12.5 mm such as a finger.	<b>2</b>	 Protected against vertically falling drops of water with enclosure tilted up to 15 degrees from the vertical. Limited ingress permitted.
<b>3</b>	 Protected against a solid object greater than 2.5 mm such as a screwdriver.	<b>3</b>	 Protected against sprays of water up to 60 degrees from the vertical. Limited ingress permitted for three minutes.
<b>4</b>	 Protected against a solid object greater than 1 mm such as a wire.	<b>4</b>	 Protected against water splashed from all directions. Limited ingress permitted.
<b>5</b>	 Dust Protected. Limited ingress of dust permitted. Will not interfere with operation of the equipment. Two to eight hours.	<b>5</b>	 Protected against jets of water. Limited ingress permitted.
<b>6</b>	 Dust tight. No ingress of dust. Two to eight hours.	<b>6</b>	 Water from heavy seas or water projected in powerful jets shall not enter the enclosure in harmful quantities.
<b>Rating Example:</b>		<b>7</b>	 Protection against the effects of immersion in water between 15 cm and 1 m for 30 minutes.
<b>IP65</b>		<b>8</b>	 Protection against the effects of immersion in water under pressure for long periods.
<b>INGRESS PROTECTION</b>			

## 6 Wiring

OPTOTRONIC Outdoor LED Drivers can be remote mounted up to 16 feet from the LED load. This may vary depending on the wire gauge and wiring routing. Further wiring configurations are discussed below.

### 6.1 Series Connection

A constant current LED driver can power LED modules in series or parallel connection. The following schematic shows a series connection of LED modules that require 350mA to operate them. A 350mA CC driver is used to power the LED modules.

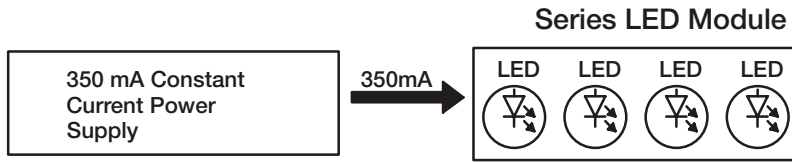

### 6.2 Parallel Connection

The second illustration is a Parallel/Series LED module. It shows that it can also be powered with a CC 700mA driver. The current needs to be "split" equally among the two strings of series LED modules.

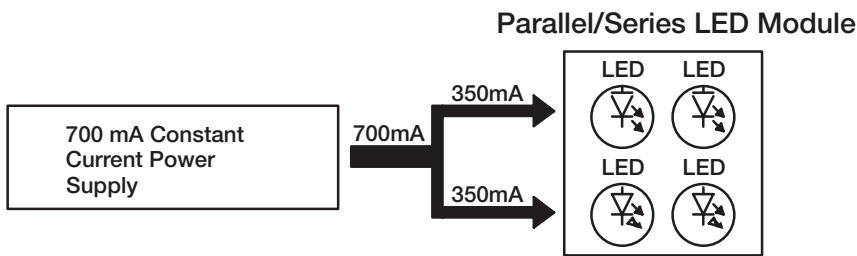

OPTOTRONIC LED Drivers can be connected in parallel on the primary side. However, unlike conventional transformers, OPTOTRONIC LED Drivers cannot be connected in parallel on the secondary side as this may lead to an unequal load distribution and overload of individual driver.



## 7 EMI

To ensure radio interference suppression and maximum safety, the following rules for cable routing should be observed:

1. Avoid crossing AC mains cables and LED module cables. In applications where this is not possible, cables should cross at right angles (to avoid HF interference on the mains cable).
2. Keep output cables and mains cables as far away from one another as possible (e.g. 5 to 10 cm). This avoids mutual interference between mains and secondary-side cables.
3. Keep AC mains line cables in the luminaire as short as possible to reduce interference.
4. Ground the lighting system chassis and other internal metal parts to earth. Always use the safety or functional earth connector or wire from the lamp driver.
5. Cable penetrations through metal components must never be left unprotected and should be fitted with additional insulation (sleeve, grommet, edge protector, etc.)

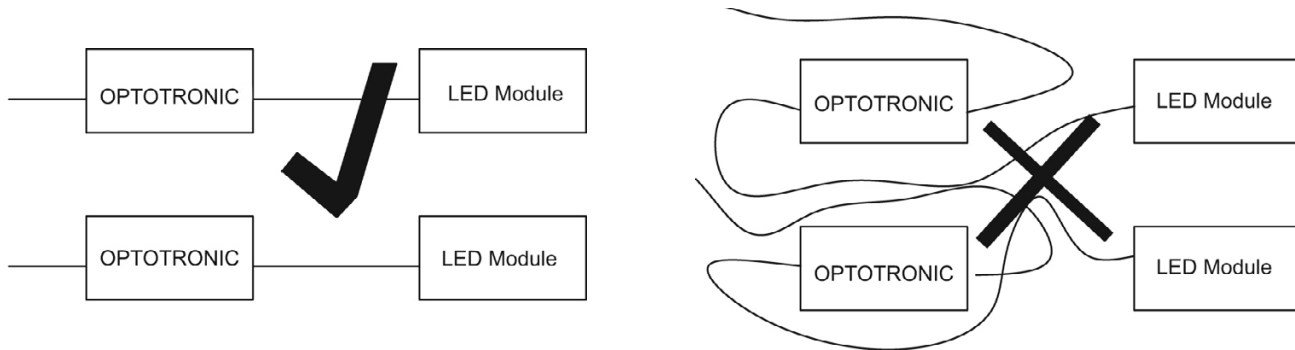

## 8 Thermal Protection

OPTOTRONIC LED drivers are designed for high efficiency and reliable operation even in elevated ambient temperatures. Thermal management of these devices is nonetheless important and can greatly improve the lifetime of the LED drivers in an installation.

Proper thermal management is best verified by measuring the temperature at the device's  $T_c$  point during steady-state operation at maximum load. The measured temperature must not exceed the maximum specified value for the OPTOTRONIC device.

To avoid overheating, the OPTOTRONIC LED driver should be installed as far away as possible from any external heat source (e.g. the LED modules). When installing OPTOTRONIC devices in a luminaire, a good thermal contact between the LED driver and the housing of the lighting fixture is required. To improve thermals use a metal base plate connected to the outside or metallic boxes.

There are two types of programmable thermal protection features available with OPTOTRONIC drivers:

### 8.1 Driver Thermal Protection

To protect the driver from overheating, all OPTOTRONIC Outdoor LED Drivers have built in NTC that prevents the driver case temperature ( $T_c$ ) from exceeding a threshold.

When this feature is turned on through the OT Programmer, the driver can detect abnormal rise in  $T_c$  and will trigger a bi-level current foldback by folding back to 60% of programmed output current setting. The decrease in the output power helps alleviate the thermal stress on the component.

The driver automatically recovers as soon as the  $T_c$  drops  $10^\circ\text{C}$  below trigger temperature.

Refer to the individual driver specification sheet for the specified fold back temperature threshold.

## 8.2 LED Thermal Protection

The LED Thermal Protection feature of the OT100W helps reduce the temperature of the LED module by reducing the output current in case of abnormal temperature conditions. To use this feature, a third party NTC thermistor should be connected to the LED driver as shown in the wiring diagram below.

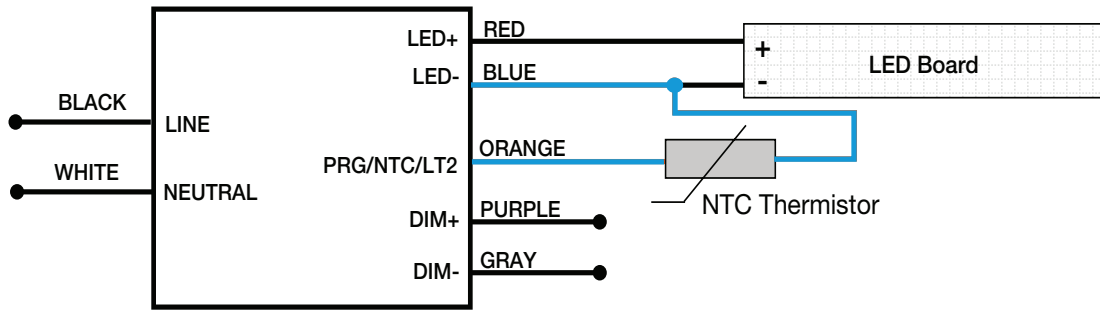

The NTC behavior graph can be used as a guideline in choosing the derating settings in terms of kilo-ohms in the LED driver configurator tool. There are three parameters that are configurable:

- Temperature Derating Start: This is the threshold in resistance ( $k\Omega$ ) after which the driver triggers the protection and begins to scale back the output current.
- Temperature Derating End: This is the cut-off point in resistance ( $k\Omega$ ) after which the output current would stop its foldback.
- Minimum Output Level: This is the percentage of the programmed current that is finally achieved at the derating end point.

LED Thermal Protection

Use default values
  Use custom values 1

Temperature Derating Start: 2  k $\Omega$

Temperature Derating End: 3  k $\Omega$

Minimum Output Level: 4  %

[View Derating Curve](#)

Derating Curve – 1

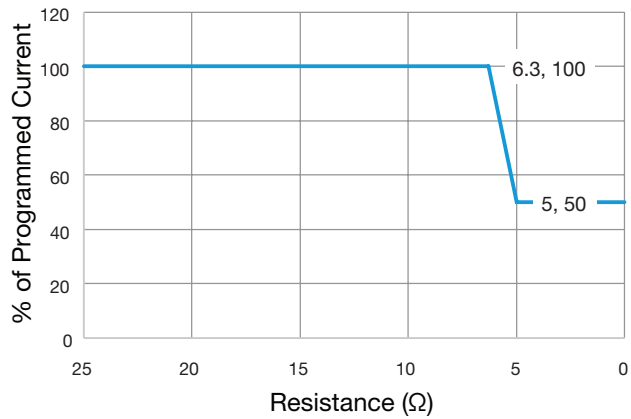

## 9 Surge

All OPTOTRONIC Outdoor Programmable LED Drivers have built in 6kV “dual stage” surge protection as per ANSI C82.77-5-2017 voltage surge requirements standard. Depending on quality of AC mains voltage and local requirements, additional external surge protection against excessively high voltages may be required which can be achieved by using an external Surge Protection Device (SPD).

OPTOTRONIC Outdoor Drivers have a dual stage surge protection feature which enhances the reliability of the driver in the event of lightning/surge.

The input (primary) side of the OPTOTRONIC Driver has two stages. Stage 1 faces the first attack of the surge strike and is thus rated for high peak surge voltages (6kV).

After the surge passes through this stage, it still has residual energy left which can harm the components inside the driver. To prevent that, Stage 2 is incorporated and is rated for lower residual voltages.

Stage 2 also helps in protecting the driver from consistent over-voltages which are not high enough to trigger Stage 1 but are capable of causing harm to the driver.

The following figure shows how the dual stage surge protection is designed in OPTOTRONIC Outdoor Drivers:

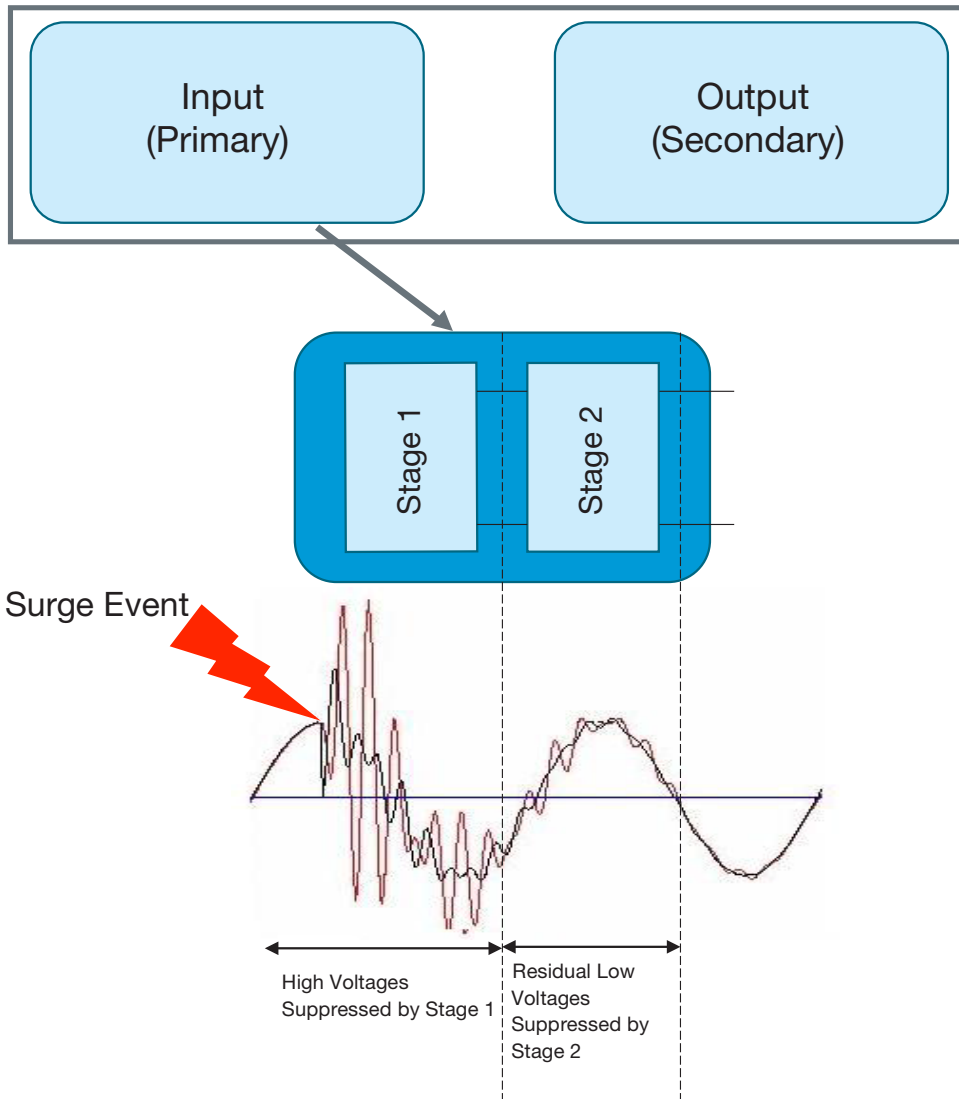



The following table is taken from the ANSI C82.77-5-2017 for combination wave and ring wave parameters:

### Standard 1.2/50 µs-8/20 µs Combination Wave Specification

Description	Test Level/Configuration		
1.2/50 µs Open Circuit Voltage Peak	Low: 6kV	Med: 10kV	High: 20kV
8/20 µs Short Circuit Current Peak	Low: 3kA	Med: 5kA	High: 10kA
Coupling Modes <sup>1</sup>	L1 to G, L2 to G, L1 and L2 to G, L1 to L2		
Polarity and Phase Angle	Positive at 90° and Negative to 270°		
Test Strikes	# of each coupling mode and polarity/phase angle combination		
Time Between Strikes	1 minute ±15 seconds		
Total Number of Strikes	# strikes x 4 coupling modes x 2 polarity/phase angles equals total strikes		

1. L1 is typically HOT; L2 is typically NEUTRAL; G = Ground

### Standard 0.5 µs-100 kHz Ring Wave Specification

Parameter	Test Level/Configuration	
Short Circuit Current Peak	0.2kA (Category A)	0.5kA (Category B & C)
Open Circuit Voltage Peak	2.5kV or 6kV as specified	
Coupling Modes <sup>1</sup>	L1 to G, L2 to G, L1 and L2 to G, L1 to L2	
Polarity and Phase Angle	Positive at 90° and Negative to 270°	
Test Strikes	# of each coupling mode and polarity/phase angle combination	
Time Between Strikes	1 minute ±15 seconds	
Total Number of Strikes	# strikes x 4 coupling modes x 2 polarity/phase angles equals total strikes	

1. L1 is typically HOT; L2 is typically NEUTRAL; G = Ground

#### Please note:

All information in this guide has been prepared with great care. eldoLED, however, does not accept liability for possible errors, changes and/or omissions. This technical application guide is for information purposes only and aims to support you in tackling the challenges and taking full advantage of all opportunities the technology has to offer. Please note that this guide is based on our measurements, tests, specific parameters and assumptions. Individual applications may not be covered and need different handling. Responsibility and testing obligations remain with the luminaire manufacturer/OEM/application planner.

eldoLED

One Lithonia Way  
Conyers, GA 30012  
United States

+1 877 353 6533

nasupport@eldoLED.com

www.eldoLED.com

© 2022 Acuity Brands Lighting, Inc.  
Specifications subject to change without notice. Actual performance may differ as a result of end-user environment and application.