

# ASSEMBLY INSTRUCTIONS TABLE SETH

# zUiver<sup>o</sup>

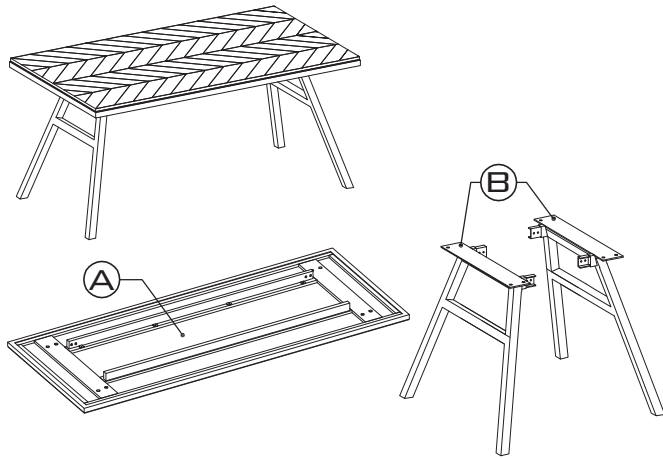

## PARTS CHECK LIST

CODE	COMPONENTS	QTY
(A)	TOP TABLE	x01
(B)	LEG FRAME	x02

## HARDWARE CHECK LIST

CODE	DESCRIPTION	QTY
01	LONG BOLT	x08
02	SHORT BOLT	x08
03	SPRING WASHER	x08
04	FLAT WASHER	x08
05	ALLEN KEY	x01

- PLEASE DO NOT DISCARD ANY OF THE PACKAGING UNTIL YOU HAVE CHECKED ALL THE PARTS AND THE PACKS OF HARDWARE.  
 - BEFORE YOU BEGIN TO ASSEMBLE YOUR NEW PIECE OF FURNITURE, PLEASE CHECK TO ENSURE THAT ALL PARTS HAVE BEEN SUPPLIED.  
 - FOLLOW INSTRUCTIONS CLOSELY AS DEVIATION FROM THEM MAY VOID YOUR WARRANTY AND PRESENT A POSSIBLE SAFETY RISK.  
 - IT IS RECOMMENDED THAT ASSEMBLY IS DONE ON A SOFT SURFACE LIKE CARPET TO AVOID ANY DAMAGE.  
 - PERIODICALLY CHECK AND RE-TIGHTEN ANY FASTENERS. WIPE DOWN ALL SURFACES WEEKLY WITH A CLEAN CLOTH. DO NOT CLEAN ANY SURFACES WITH HARSH ABRASIVES OR CHEMICALS.

1.

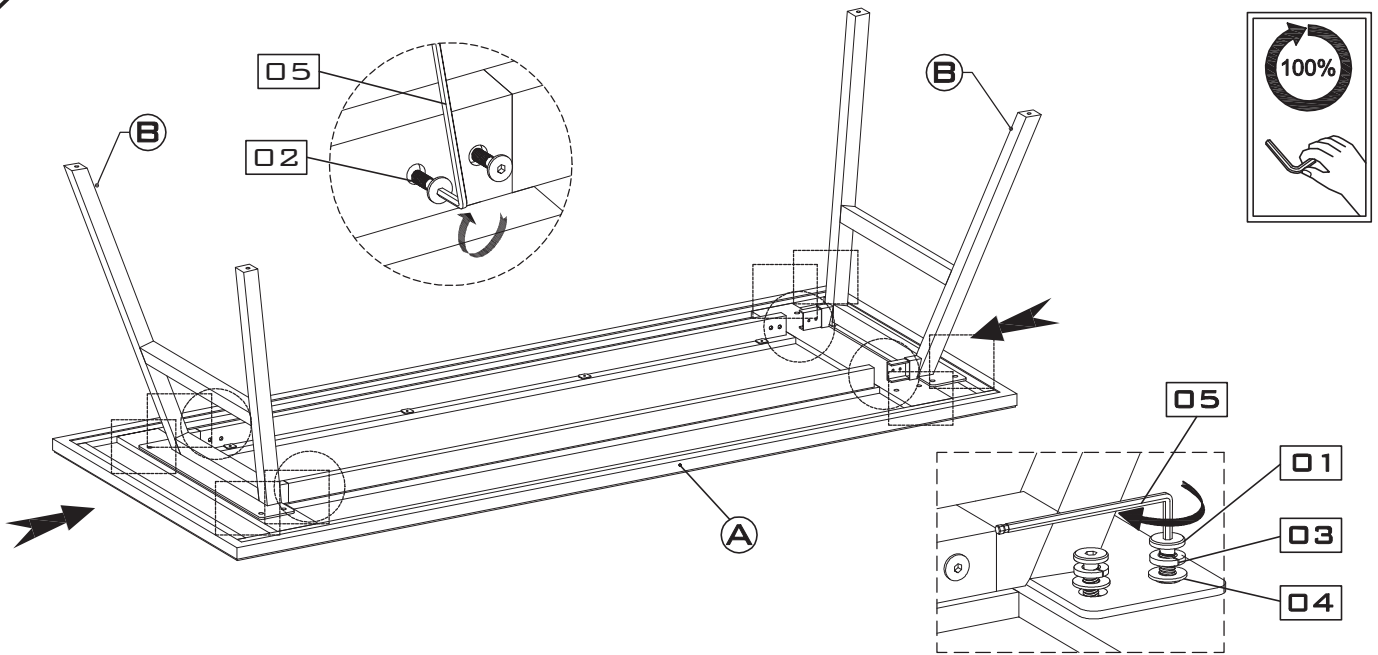

2.

