

## Gift Bag and Jewelry Pouch Pattern

Elegance can be easy. Make lovely gift bags or jewelry pouches for all your best friends. Selecting beautiful fabrics will be the hardest part of making this treasure trove.

### FINISHED SIZE:

Approximately 20" in diameter

### NEEDED SUPPLIES:

- 5/8 yd. Fabric
- 5/8 yd. Lining fabric
- 3 1/2 yd. Silky cord or 1/8" wide ribbon
- Coordinating all-purpose thread
- Optional: 5/8 yd. Lightweight fusible interfacing

### HELPFUL NOTIONS:

- Rotary cutter, mat, and ruler
- Yardstick Compass
- Pattern tracing paper
- Erasable fabric marking pen or pencil
- Scraps of tear-away stabilizer
- Straight pins
- Bodkin, such as the Clip 'n Glide Bodkin
- Optional: 6-in-1 Stick 'n Stitch Guide
- Optional: 1/4" wide strips of pressure sensitive sticky fusible web tape, such as EZ-Steam® II Tape or Steam-A-Seam 2®

### Instructions: (Read all instructions before beginning.)

*Note: All seam allowances are 1/4."*

1. Make two circle patterns with the Yardstick Compass and pattern tracing paper:

- Draw a pattern for a 20 1/2" circle (pouch).
- Draw a pattern for a 16" circle (pocket).

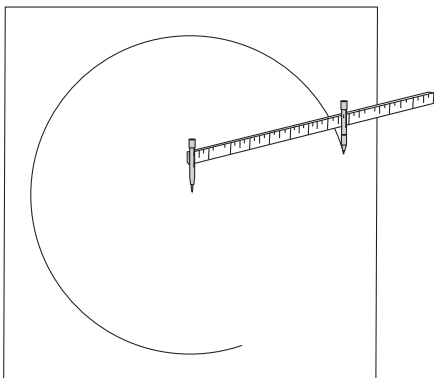

2. Cut the fabrics using patterns made in Step 1:

- Cut one 20 1/2" pouch circle from both fabric and lining.
- Cut one 20 1/2" pouch circle from lightweight fusible interfacing if using a lightweight lining fabric and you plan to add the pocket.



**sewing with nancy hint** *The fusible interfacing will strengthen the lining, helping support the pocket.*

- Optional: Cut one 16" pocket circle from both fabric and lining.

*Note: for gift pouches, skip the pockets. You will be able to cut two 20 1/2" pouch circles from the fabric and lining.*

3. Fold the 20 1/2" pouch fabric circle in half, wrong sides together. Finger press mark center line; open flat.
4. If you wish to add embroidery or other embellishment, mark two parallel casing lines:
  - Draw the lines 1" and 1 3/4" from the outer edge using an erasable fabric marking pen or pencil on the right side of the pouch fabric 20 1/2" circle.
  - Mark a 3" circle in the center of the fabric circle (6" in diameter).

5. Stitch a buttonhole for the casing opening:
  - Stitch a ½" buttonhole through a single thickness of the pouch fabric along each end of the center line, beginning 1" from the fabric edge.

*Note: Place a small piece of tear-away stabilizer behind the buttonhole area to stabilize the fabric before stitching.*

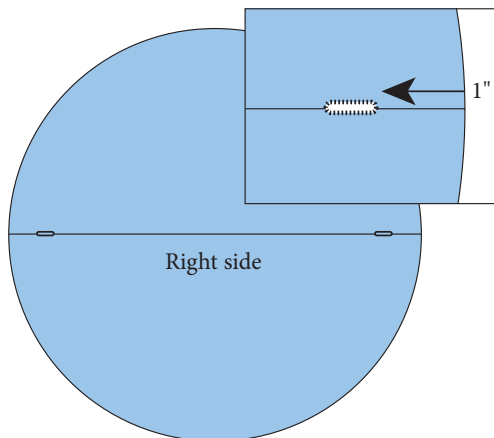

- Remove excess stabilizer and cut open buttonholes.
6. Embellish or embroider the pouch fabric circle, if desired. The marked casing and center circle lines provide the ideal space in which to personalize the pouch.
  7. Join the two 16" pocket circles, right sides together, leaving a 2" opening for turning.

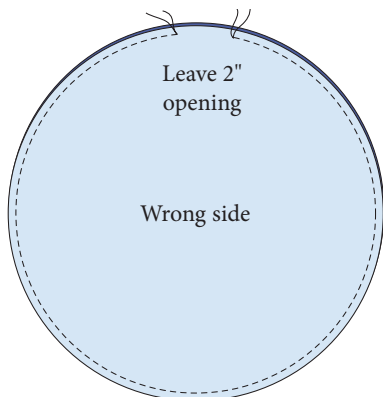

8. Turn stitched pocket circles right side out; press. Stitch opening closed, or fuse the opening shut using a ¼" wide strip of pressure sensitive sticky fusible web tape.

**sewing with nancy hint** For a quick "no-turn" option: Place pocket circles, wrong sides together, and serge the outer edges together using a three-thread overlock stitch with a decorative serger thread. Repeat for Step 13.

9. Divide the joined pocket circle into eight equal sections; fold circle in half; mark. Fold circle in half again; mark. Fold a third and fourth time, mark. This creates eight equal wedges.
10. Center the sewn and marked pocket circle over the 20½" pouch lining circle, meeting lining to lining; pin.
11. Join the pocket and pouch lining circles, stitching along marked lines of the pocket from one edge to the opposite edge; backstitch.

12. Join the two 20½" pouch circles of fabric and lining, right sides together, leaving a 2" opening for turning.
13. Turn stitched pouch circles right side out, press. Stitch opening closed, or fuse the opening shut using a ¼" wide strip of pressure sensitive sticky fusible web tape.

14. Make a casing on the joined pouch circles by stitching two parallel lines, ¾" and 1½" from the outer edge. Buttonholes will be between the two stitching lines.

*Note: If the pouch fabric was marked with casing lines prior to embellishment, simply stitch on the marked casing lines.*

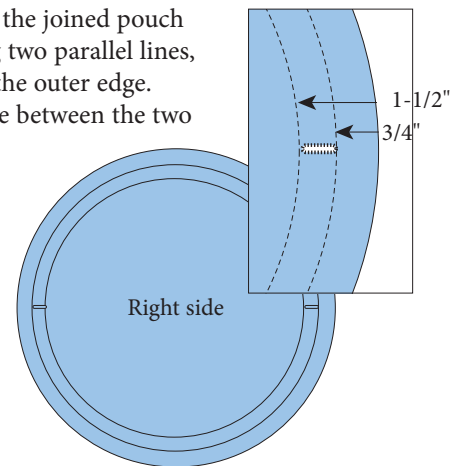

**sewing with nancy hint** The 6-in-1 Stick 'n Stitch Guide is very helpful in guiding the outer edge of the circle for stitching.



15. Stitch a 3" circle in the center of the joined circles. This prevents items from getting lodged in the small triangular openings in the center of the pouch. It also stabilizes the base if you have chosen not to add the pocket.

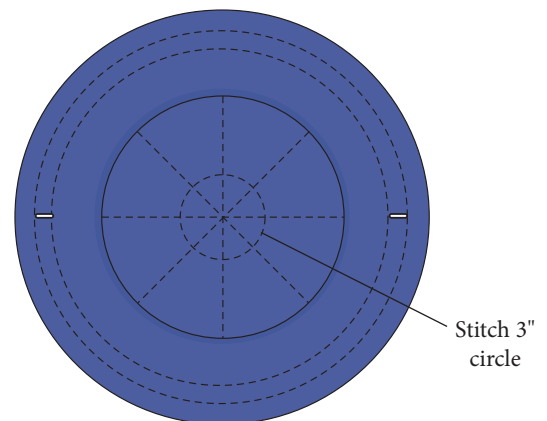

16. Cut cord or ribbon in half. Thread one of the 60" lengths through the casing with a bodkin, beginning and ending at the same buttonhole; tie cording ends together. Thread the second length through the opposite buttonhole; tie ends. Draw the tie ends to close the pouch.