

Encircled Throw Quilt Pattern

Geometrics are a favorite with quilters, with circles being a coveted favorite. This charming quilt pattern is designed to work with the *Circles Sew Simple Book and Tool*, which help you stitch perfectly symmetrical circles with ease. We've included additional circle cutting and sewing methods, if you don't have the *Circles Sew Simple Tool and Book*. Consider precut 10" squares of fabric for this pattern. Because the fabric selection and much of the cutting have already been done for you with precuts, the quilting process is simplified. Much of the time previously spent searching for just the right fabric to coordinate with others is eliminated, and cutting is reduced to a minimum. That means you can spend more time on the "fun" part of quilting. To enlarge to a bed-size quilt, simply purchase additional fabric and add additional blocks. Enjoy creating this easy, yet artistic quilt.

Note: The exact size of precut 10" fabric squares vary depending on the manufacturer. Measure squares before using them. Some may require a little trimming. For this pattern, we recommend trimming squares to 9¾" x 9¾".

APPROXIMATE FINISHED SIZE: 37¼" x 46½"

SUPPLIES NEEDED:

- Forty 10" squares of fabric (background and circles)—choose one of these options:
 - One package of precut 10" squares of assorted fabric prints with a minimum of 40 squares, such as a Layer Cake
- Or**
- ⅓ yd. of 40 assorted fabric prints (to cut into squares)
- ⅜ yd. binding fabric
- 1½ yd. backing fabric
- Crib size batting, approximately 45" x 60"
- Lightweight tear-away stabilizer
- Matching all-purpose thread (construction)
- Contrasting or matching rayon thread, as desired (appliquing)
- Lightweight bobbin thread (appliquing)



For a not so scrappy look, use only 10 or 20 fabric prints.

HELPFUL NOTIONS:

- Circle sewing/cutting notion—choose one of these options:
 - *Circles Sew Simple Tool and Book*
- Or**
- Tack and tape
- Or**
- Manual circle cutter, such as Olfa® Rotary Circle Cutter or TrueCut Circle Cutter



Or

- Electronic cutting tool, such as the Silhouette Cameo 2
- Spray starch or starch alternative, such as Best Press™
- Rotary cutter, mat, and ruler
- Embroidery needle, size 75/11
- Universal needle, size 80/12
- Quilting needle, size 90/14
- Open Toe Foot
- ¼" piecing foot, such as Little Foot® or Patchwork Foot
- Free motion foot, such as Big Foot®
- Appliqué scissors
- Sewer's Fix-It Tape or masking tape
- Pressure sensitive fusible web tape, such as Lite EZ Steam™ II
- Wonder Clips
- Optional: Curved basting pins, size 1
- Optional: Fabric glue stick
- Optional: Temporary spray adhesive, such as 505® Spray and Fix Adhesive

INSTRUCTIONS: (Read all instructions before beginning.)

Note: All seams are $\frac{1}{4}$ " unless otherwise noted.

1. Prepare and cut fabric and stabilizer:

- As noted in the supplies, choose either precut fabric squares or cut fabric yardage and begin with one of the options below:

- **Option 1:** Use precut fabric squares:

- * Stabilize all precut fabric squares well with a spray starch or starch alternative. Let dry completely.



- * Square the precut fabric squares by trimming to an accurate $9\frac{3}{4}$ " x $9\frac{3}{4}$ " square.

- **Option 2:** Cut fabric squares from fabric yardage:

- * Stabilize fabric yardage well with a spray starch or starch alternative. Let dry completely.
- * With fabric folded in half, selvage edge to selvage edge, cut one $9\frac{3}{4}$ " wide crosswise strip from each of the fabrics.

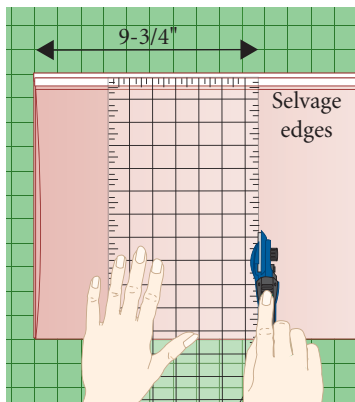

- * Trim off the selvage edges from crosswise fabric strips.

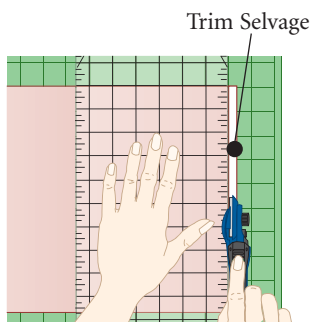

- * Subcut $9\frac{3}{4}$ " fabric squares from each strip.

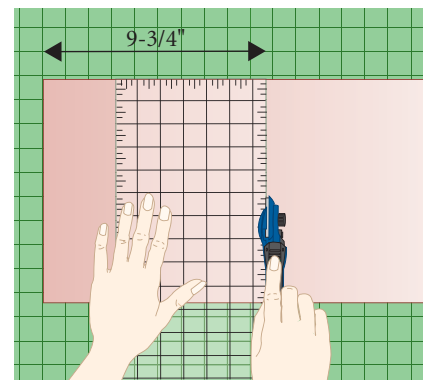

sewing with
nancy
hint

If cutting numerous squares of the same size, layer two to four fabric strips as evenly as possible, right side facing up.

- Cut stabilizer:

- Cut twenty 10" squares.

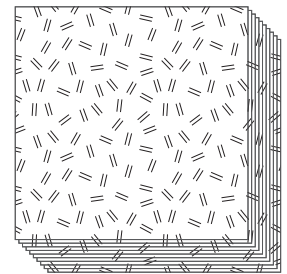
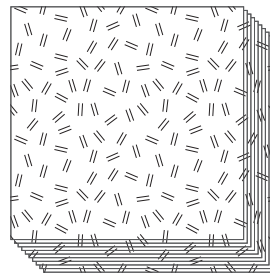

- Cut binding strips:

- With binding fabric folded in half, selvage edge to selvage edge, cut five $2\frac{1}{2}$ " wide crosswise strips.

2. Prepare fabric squares:

- Pair squares in sets of two, determining which square will be the background block square and which will be the appliqué circle.

sewing with
nancy
hint

Pair the fabric square sets in a pleasing manner, alternating light, medium, and dark colors.

- Mark the background and appliqué circle squares to determine the center:

- Fold each fabric square into quarters and finger press mark the center and the center of each of the sides.

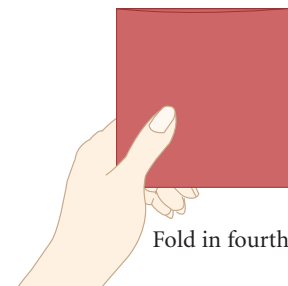

- Layer the twenty sets with the background block square fabric on the bottom and appliqué circle fabric on top.

3. Set up sewing machine and stitch appliqué blocks:

Note: Allow the fabric to feed smoothly underneath the foot. Do not push or pull the fabric, as it may cause an uneven circle.

- Insert a new embroidery needle, size 75/11.
- Thread the needle with contrasting or matching rayon thread for appliquéing.
- Wind a bobbin with lightweight bobbin thread, and insert into the machine.
- Attach an Open Toe Foot. The underside of the foot is grooved, allowing stitches to follow in the hollowed out area to easily flow under the foot.



Open Toe Foot



Bottom of Open Toe Foot

- Stitch appliqué the circles on the background fabric square using one of the following techniques:

- **Option 1** – Circle Sew Simple Tool Technique:

- * Refer to the Circle Sew Simple Tool and Book, pages 1-3, using the below instructions as a guide:
 - Attach the Circles Sew Simple Tool and slide Tack to circle size 8".
 - Cover the Tack with the Cross Bar Attachment.
 - Position a background block square of fabric backed with stabilizer, right side up, positioning the center marking on the Tack.
 - Position an appliqué circle fabric, right side up, positioning the center marking on the Tack. Cover Tack with Guard.
 - Set machine for a straight stitch; sew an 8" circle.

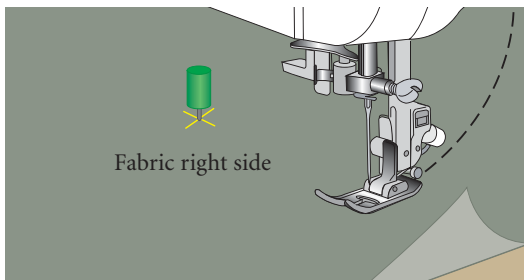

- Trim close to the straight stitch with an appliqué scissors.

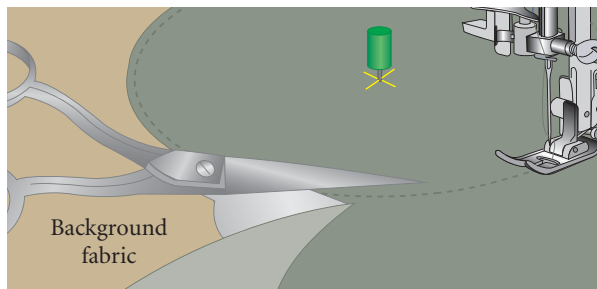

- Set machine for a satin stitch and stitch again over the 8" straight stitched circle.

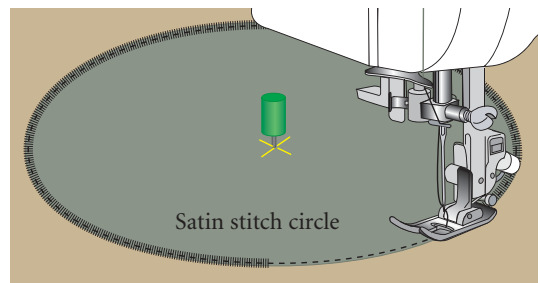

Note: For a different look, adjust your machine using other decorative stitches, such as the blanket stitch, blind hem stitch or the zig zag stitch.

- Repeat for the remaining fabric square sets.
- **Option 2** – Low Tech Taped Tack Technique:
 - * Position a section of tape over the point of the tack, and press the tape down to adhere it to the tack base.
 - * Measure 4" to the left of the needle and place the tack point side up, directly across from the needle.

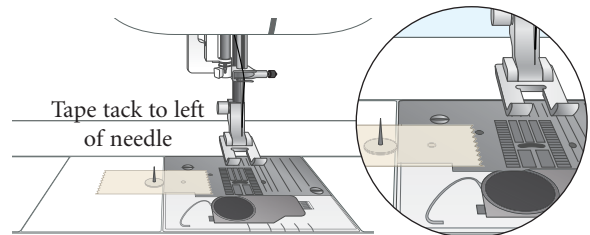

- * Tape the thumbtack to the bed of the machine.
- * Position a background block square of fabric backed with stabilizer, right side up, positioning the center marking on the Tack.

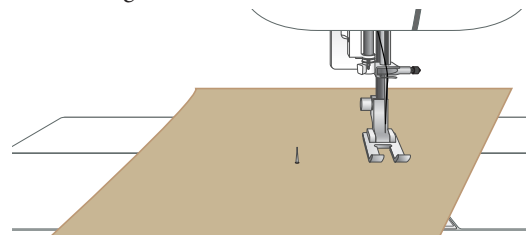

- * Position an appliqué circle fabric, right side up, positioning the center marking on the Tack.
- * Set machine for a straight stitch; sew an 8" circle.

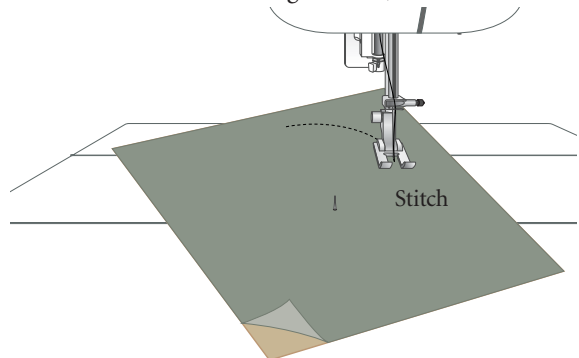

- * Trim close to the straight stitch with an appliqué scissors.

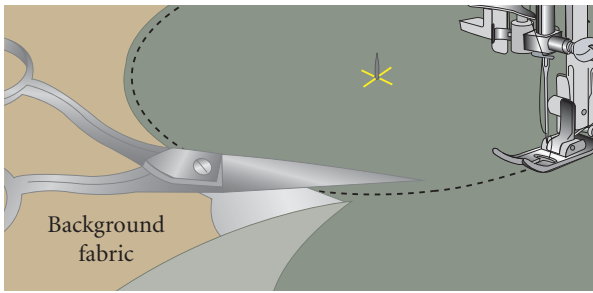

- * Set machine for a satin stitch, or your choice of decorative stitch, and stitch again over the 8" straight stitched circle.

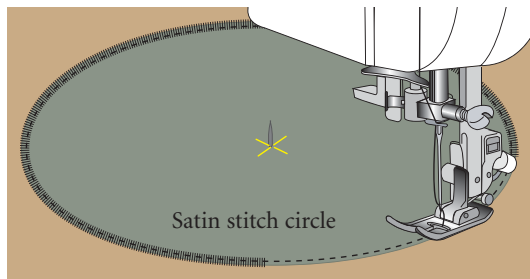

- * Repeat for the remaining fabric square sets.
- **Option 3 – Precut Circles and Appliqué Technique:**
- * Choose one of the following techniques to precut the appliqué circle fabric:
 - Manual circle cutters: Cut 8" fabric circles using an Olfa® Circle Cutter or TrueCut Circle Cutter following the manufacturers' instructions.

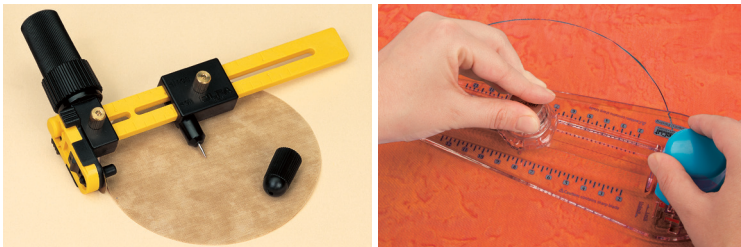

- Electronic cutting tool: Cut 8" fabric circles following the manufacturers' instructions.



- Paper circle template: Draw and cut an 8" circle from a piece of medium weight cardstock. With a glue stick, place a tab of glue on the back of the circle template and place it on the wrong side of the circle fabric. Cut with a fabric scissors along the edge of the template.

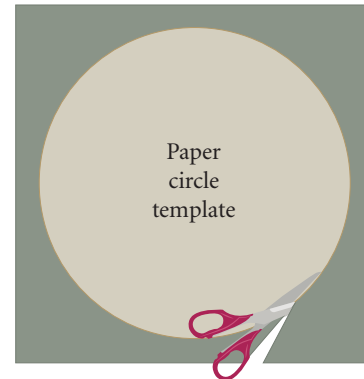

- * Stitch the precut circles on the background fabric square:
 - Position a precut circle, right side up and centered, over a background block square fabric backed with stabilizer. Pin.
 - Set machine for a straight stitch; sew the circle following the cut edge as a guide. Remove pins as you go.

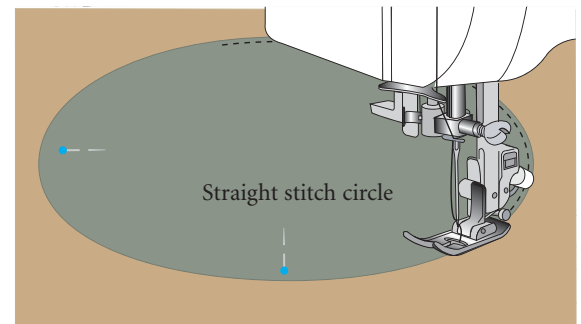

- Set machine for a satin stitch, or your choice of decorative stitch, and stitch again over the 8" straight stitched circle.

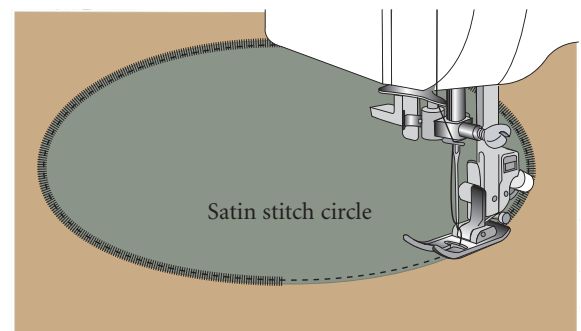

- Repeat for the remaining fabric square sets.
- Gently remove the excess stabilizer from the back of the blocks.
- Press the blocks flat.

4. Construct the quilt top:

- Arrange the blocks on a work surface or design wall laying out five rows of four blocks, as desired.

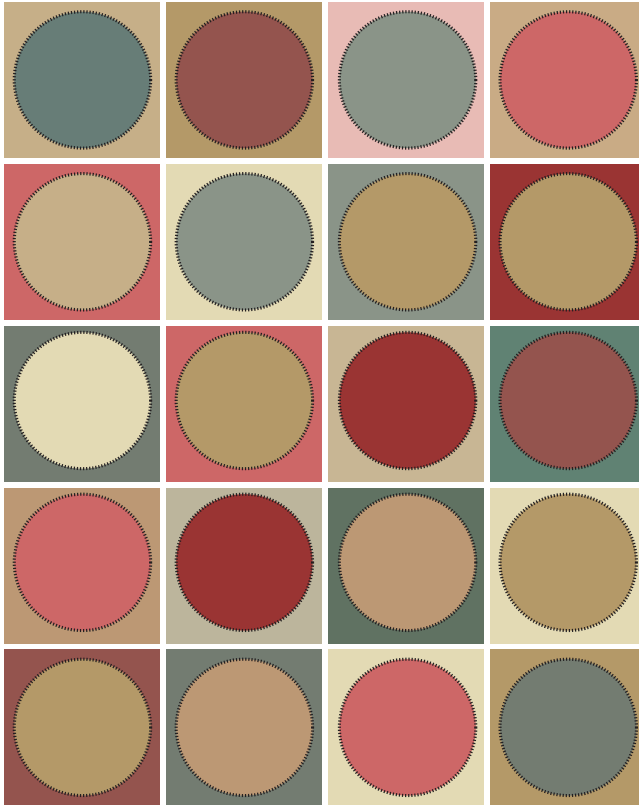

- Set up machine for 1/4" seaming:
 - Insert a new universal needle, size 80/12.
 - Attach a 1/4" piecing foot.



- Or, if the sewing machine has an adjustable needle position, attach a standard presser foot and position the needle so it is exactly 1/4" from the right edge of the foot.
- Join the four blocks in each row, right sides together, guiding the right edges of the blocks along the right edge of the foot.

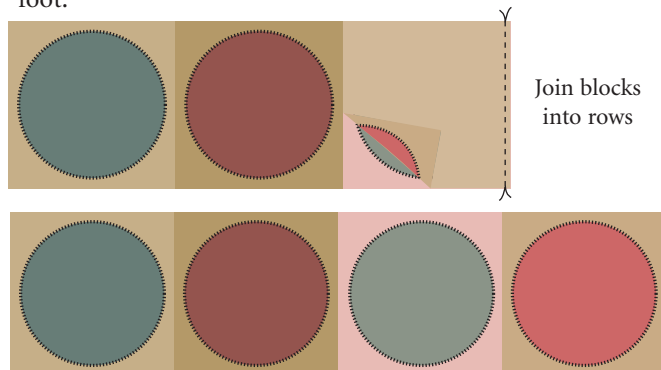

- Press seams flat, then press seams to one side in the opposite direction of the previous row.

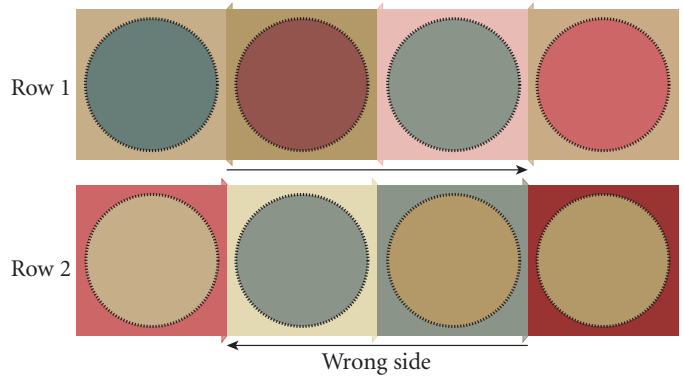

- Stitch rows together, nesting the seam allowance to complete the quilt top.
- Press seams flat; then press seams open.

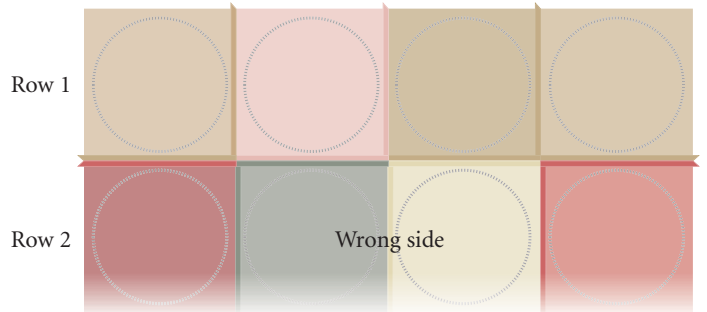

5. Layer the quilt:

- Place the backing, wrong side up, on a flat surface.
- Securely tape the backing to the surface using Sewer's Fix It Tape or masking tape.

Note: Sewer's Fix-it Tape works well for this as it holds securely and leaves no sticky residue.

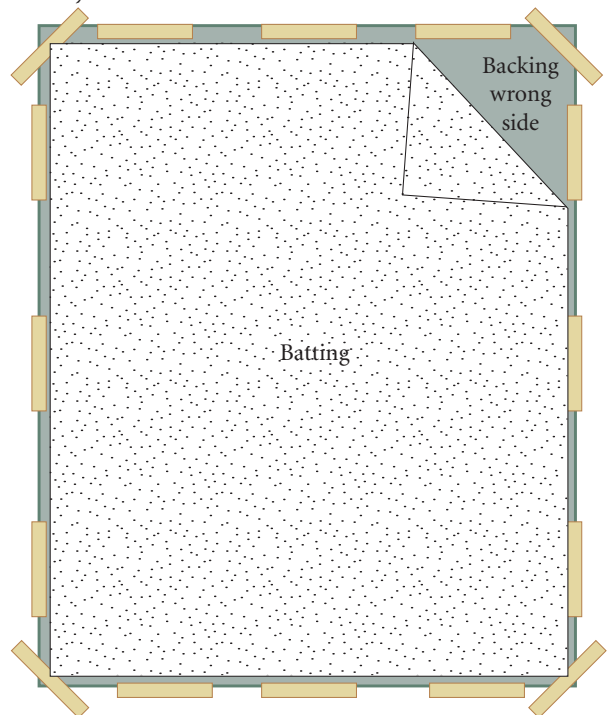

- Place the batting over the backing. Then center the quilt top, right side up, over the batting.

- Secure layers using one of these methods:
 - “Pinning” Method:
 - * Using curved basting pins, pin and baste layers together to reduce shifting while quilting.
 - “Fuse Tack” Method:
 - * Cut and press ½" squares of a pressure sensitive fusible web tape to the wrong side of the backing and quilt top, a fist width apart.
 - * Press layers together with a miniature iron or a regular iron.
 - Spray Baste Method:
 - * Layer the backing, batting and quilt top on a flat surface.
 - * Fold back the batting and quilt top. Spray the wrong side of the quilt backing using a quilt basting spray. Lay the batting on top and smooth out any wrinkles.
 - * Spray the middle section of the batting and smooth the quilt top back over that section of batting that was just sprayed.
 - * Repeat the process, spraying small sections at a time, until you reach the top of the quilt.
 - * Repeat the process working from the center of the quilt to the bottom of the quilt.
- Remove tape.

6. Quilt layers together and prepare quilt for binding:

- Insert a new quilting needle, size 90/14.
- Quilt the quilt using one of the following techniques, removing pins as you quilt:

- Stitch in the ditch, sewing in the well of the seams, between the quilt blocks.

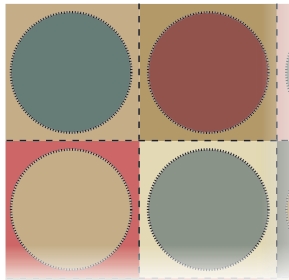

Stitch in well of seams

- Stitch using a decorative stitch, straddling the seams between the quilt blocks. There's no need to worry about stitching precisely in the well of the seams.

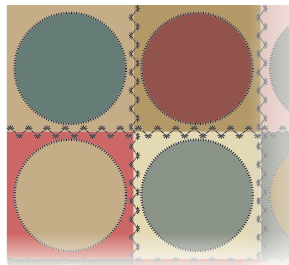

Straddle seams with decorative stitch

- Decorative “Tie” Stitch:
 - * Mark the placement for the decorative “tie” stitches 3"-4" apart.
 - * Stitch one complete decorative stitch pattern.

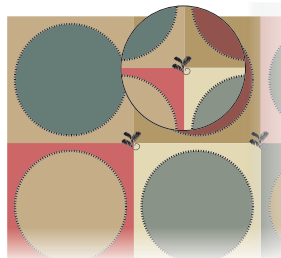

- * Cut threads; raise the presser foot, advance to the next area, and stitch another decorative “tie” stitch. Stitch over the entire quilt.
- Free motion stippling stitch, creating graceful curved designs and floral patterns over the entire quilt.

sewing with nancy hint The large saucer-shaped base on the Big Foot® provides greater surface contact and keeps the fabric flat, without being taut. The transparent foot provides excellent visibility, allowing you to see exactly where you're stitching.

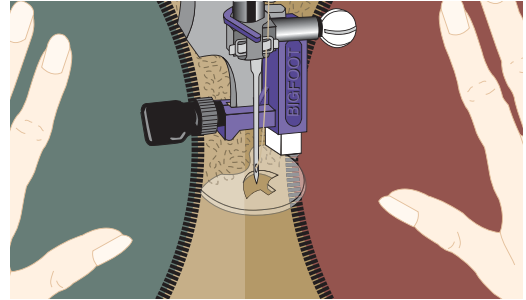

- Baste outer edges, stitching a scant ¼" from the cut edges of the quilt.

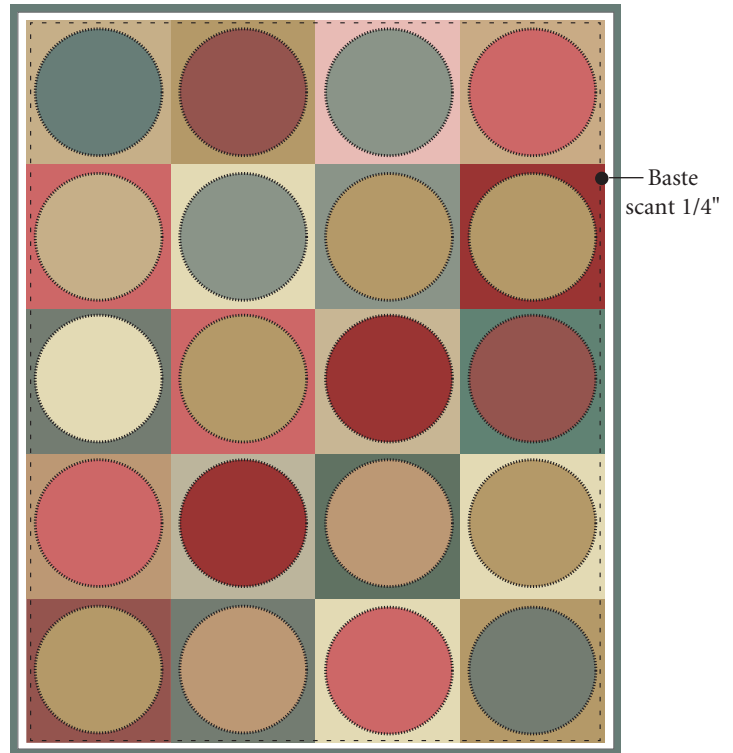

- Trim edges even with the quilt top; square the quilt if needed.

7. Bind the quilt:

- Join the short ends of the five 2½" crosswise binding strips, right sides together, using a diagonal seam to minimize bulk.
- Trim seams to ¼"; press seams open.

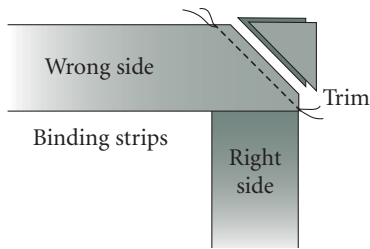

- Cut one end of the binding at a 45° angle. Fold in a generous ¼" at the beginning of the angled edge.
- Press a ¼" strip of pressure sensitive fusible web tape on top of the folded inner edge.
- Fold the binding in half, wrong sides together, meeting lengthwise edges. Press.



- Mark the quilt top ¼" from each corner.

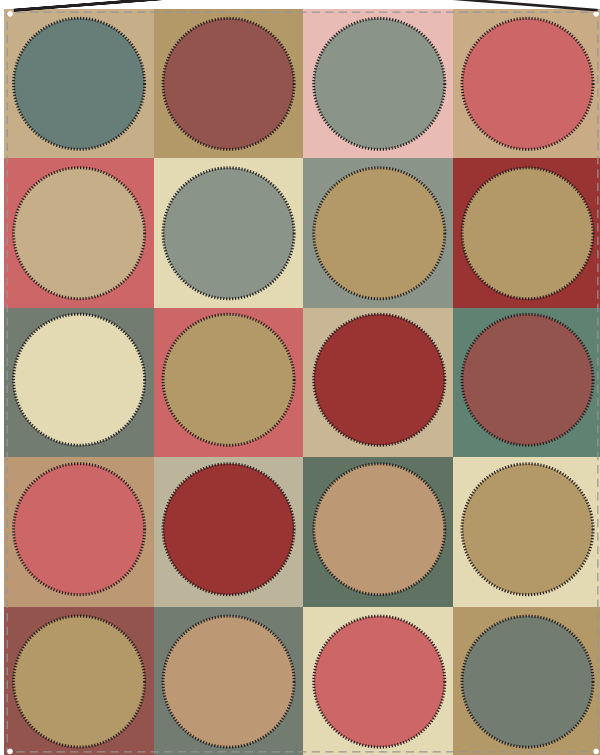

- Set up machine for ¼" seaming:
 - Attach a ¼" piecing foot.
 - Or, if the sewing machine has an adjustable needle position, attach a standard presser foot and position the needle so it is exactly ¼" from the right edge of the foot.
- Meet the raw edges of the binding to the quilt top, right sides together, starting with the angle-cut end and beginning in the center of one edge.

- Starting stitching about 4" from the end of the binding, stitch the binding to the quilt guiding the right edge of the quilt top and binding along the right edge of the foot.
- Stop stitching at the marked point, sinking the needle into the fabric. Lock stitches and cut threads. Raise the presser foot.

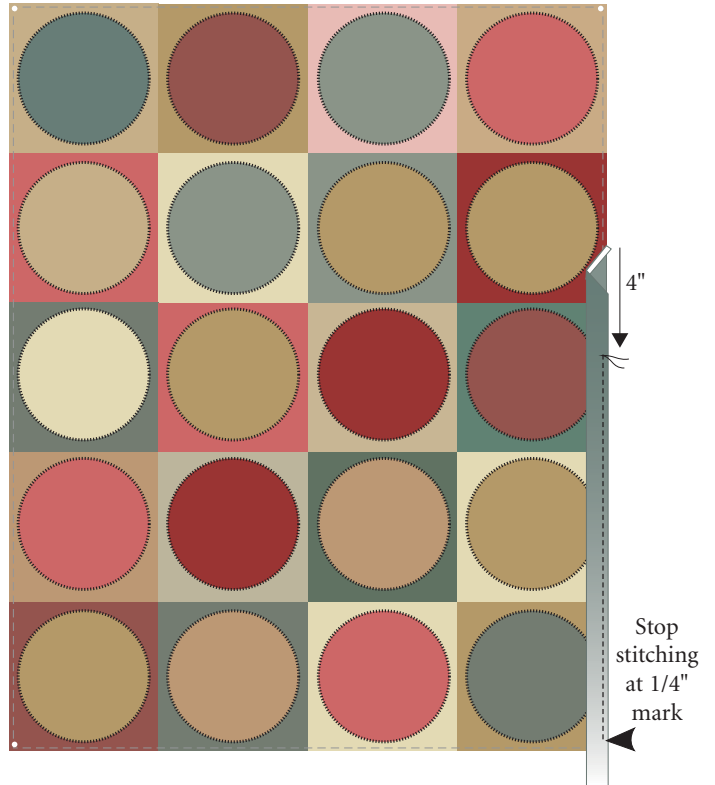

- Fold binding up at a 45° angle, aligning the cut edge of the binding with the cut edges of the quilt.

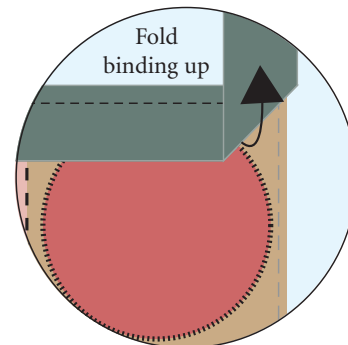

- Fold the binding down, matching the binding fold to the top edge of the quilt and matching the binding cut edges to the quilt side edges.
- Starting at the fold, stitch down the side, stopping at the next marked corner.

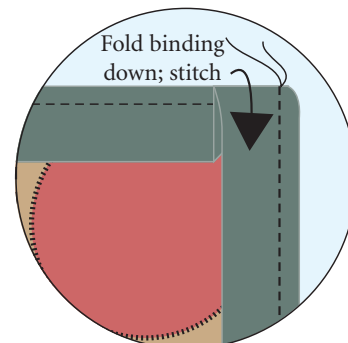

- Repeat at remaining corners. Stop stitching approximately 3" before the start of the binding. A 7" section remains unstitched.
- Remove the paper from the strip of pressure sensitive fusible web tape on the folded-under end of the binding. Insert the free end of the binding into the beginning making sure the binding is smooth and even with the edge of the quilt. Press.
- Unfold and trim the excess binding. Refold binding and stitch the remainder of the seam.

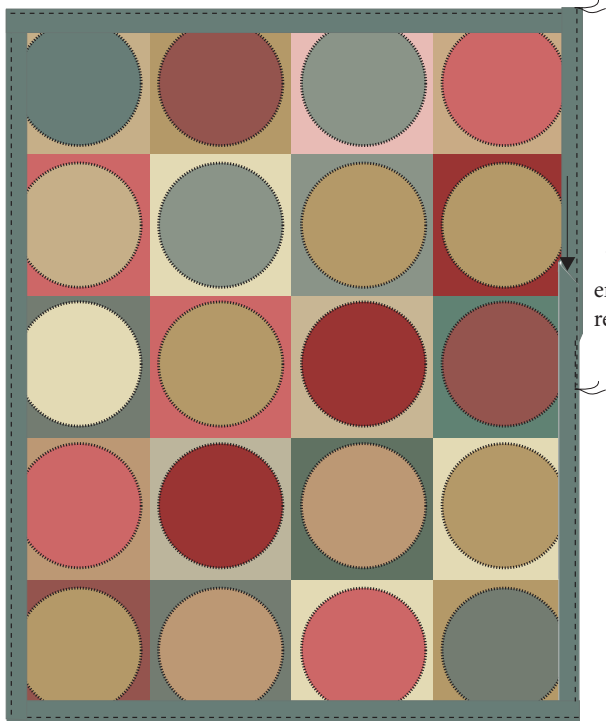

- Fold and press binding away from the quilt and to the wrong side, covering the stitching line. Tuck and fold binding to create miter corners. Pin or secure with Wonder Clips.

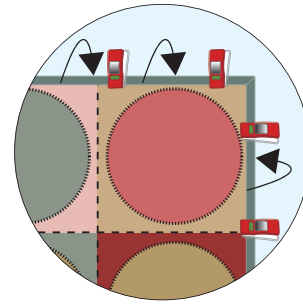

- Complete the binding using one of the following methods:
 - Stitching in the ditch, sewing in the well of the seam, using a straight stitch.
 - Slip stitch the binding to the back of the quilt by hand.

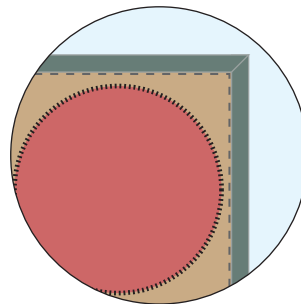

Stitch in the ditch

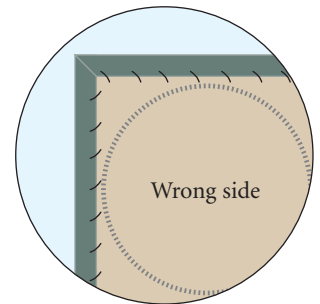

Hand stitch folded edge

Notes: