

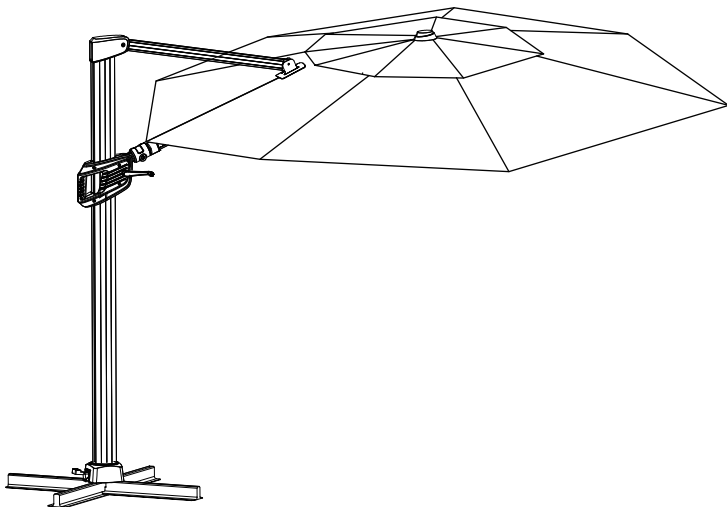

CANTILEVER

UMBRELLA



Instruction Manual

***THE DIAGRAM IS FOR REFERENCE ONLY**

IMPORTANT:

READ IT CAREFULLY AND KEEP IT FOR FUTURE REFERENCE.

SAFETY NOTES

- **IMPORTANT!** Always close/put down the umbrella when not in use. Do not use or assemble the umbrella in heavy winds, rain, thunderstorms or if it's snowing. In these weather conditions, we recommend to fold down or disassemble the umbrella.
- **IMPORTANT!** The umbrella must be secured in place at the bottom using weights or being bolted down to the ground. Make sure the ground is level and firm. Do not assemble the umbrella on sandy, muddy or loose soil.
- **IMPORTANT!** If the crank gets too hard to turn, check if the rope has come off the pulley. If you continue to turn the crank, the rope or crank handle could break.
- **IMPORTANT!** Placing the umbrella over or near a swimming pool can cause premature fading of the canopy.
- **IMPORTANT!** Keep children and pets away while setting up the umbrella.
- Children must be supervised around the umbrella.
- To prevent damage to umbrella, face the canopy against the wind.
- Do not light any fires under or near the umbrella!
- This umbrella is for outdoor use only. This umbrella is primarily intended to be used as a sunshade and not as wind protection.
- This product has been tested for domestic and commercial use.



CARE INSTRUCTIONS

- To clean the canopy fabric, use mild soap or warm water with a clean, dry cloth or soft brush to remove spots. Never use solvent-based detergents since these may bleach the material and damage the fabric. Also, do not use any alkali or acidic detergents or steam blasters to clean the umbrella.
- To clean the umbrella frame, wipe it with a mild soap solution. It is not recommended to clean plastic or metal products with a strong cleaner or an abrasive material since it may discolor or damage the surface.
- The umbrella frame is painted with a powder coating of plastic paint to protect the umbrella. The umbrella frame will not be well protected once the coating comes off (e.g. rust). To repair damaged frame, please repaint it to restore the protection.

STORAGE

- We recommend that you close the umbrella when not in use and put a waterproof cover on it. Before putting the cover on, please make sure that your umbrella is completely dry and clean. During the off-season, store the covered umbrella in a cool and dry place indoors.

DISPOSAL

- If you wish to dispose of the umbrella, do not throw it in the trash. For safety and environmental purposes, please take the umbrella to a recycling center for proper disposal.

This product is covered by U.S. Patent No.8,104,492.

PARTS LIST

A x1

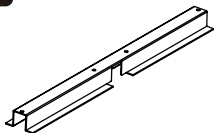

B x1

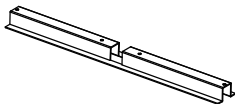

C x1

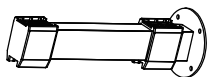

D x1

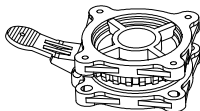

E x4



M8*22

F x8



G x1



H x1

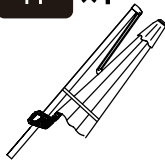

I x1



J x1



K x1

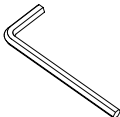

L x4



M8*32

Before beginning to assemble this product, make sure all parts are present. Compare parts with package contents list and hardware contents list. If any parts are missing or damaged, do not attempt to assemble this product. Stop and contact our customer service center.

Remove all protective materials on the product before any assembly.

STEP 1

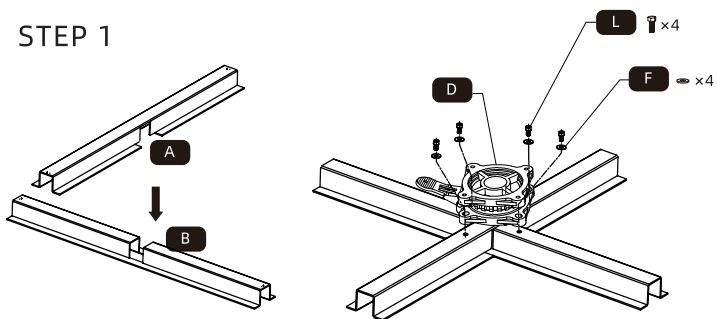

STEP 2

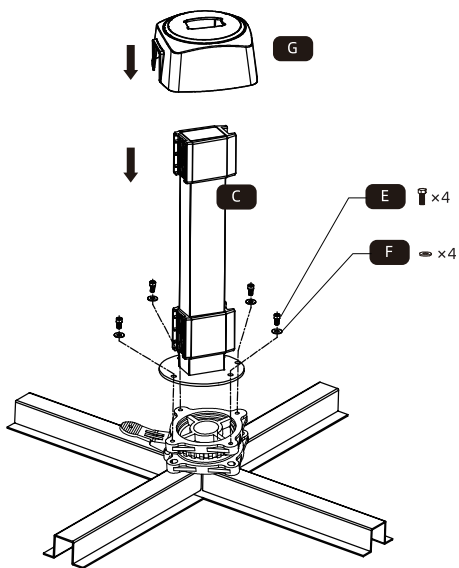

STEP 3

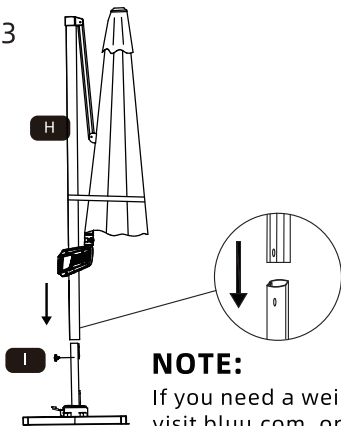

NOTE:

If you need a weight base, please visit bluu.com, or you can bolt the crossbar base down to the deck.

STEP 4

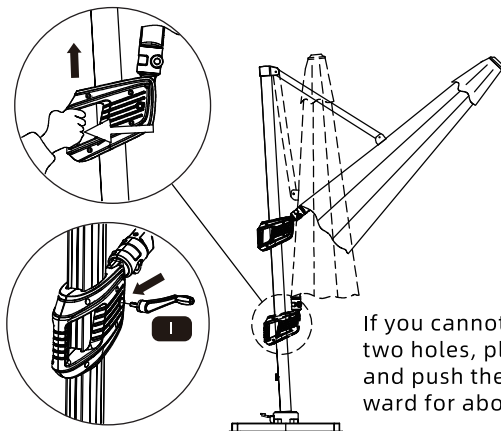

If you cannot find these two holes, please press and push the handle upward for about 5 inches.

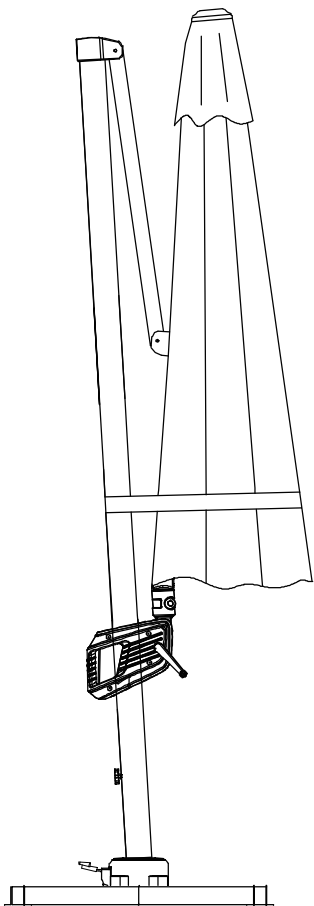

DONE!



To open the umbrella

STEP 1

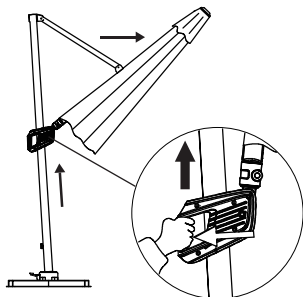

STEP 2

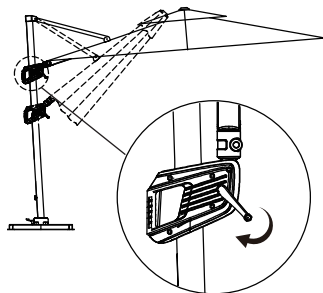

STEP 3

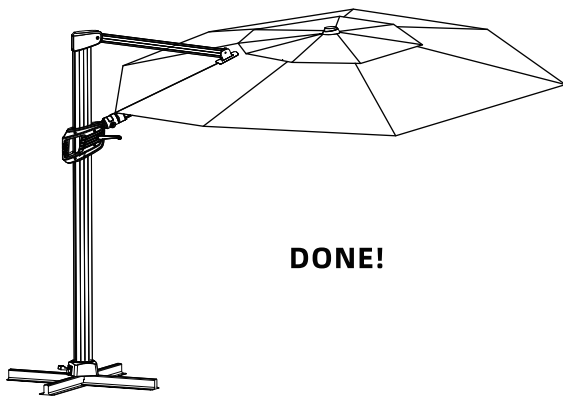

DONE!

To tilt the umbrella

STEP 1

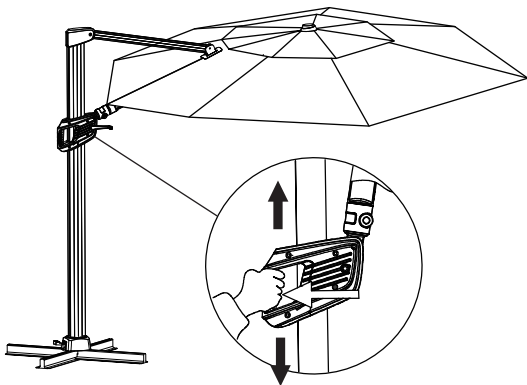

STEP 2

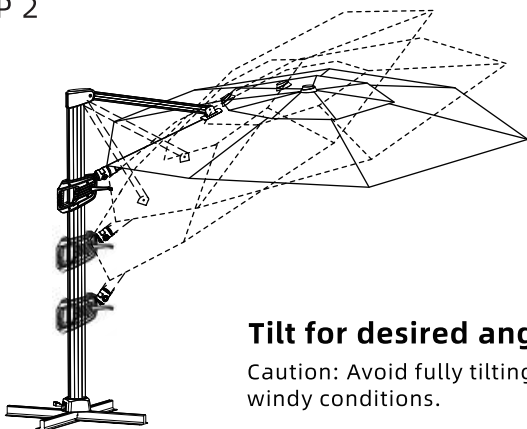

To rotate the umbrella

STEP 1

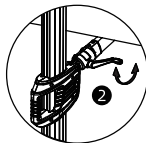
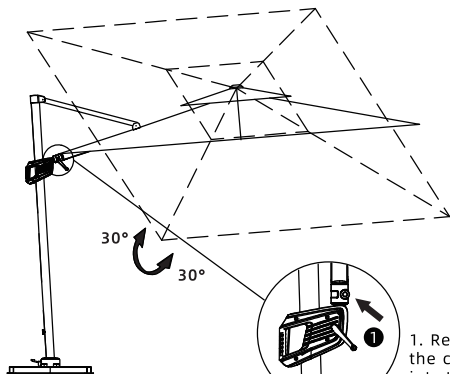

2. Use the handle to adjust the umbrella angle.

1. Remove the handle from the crank and then place it into the hole on the Main rib

STEP 2

Swivel for 360 degrees.

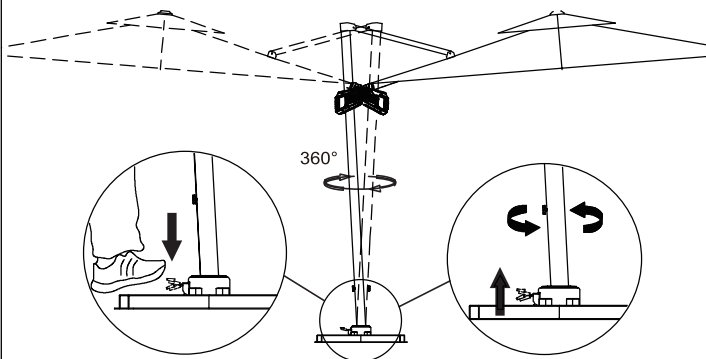

To close the umbrella

STEP 1

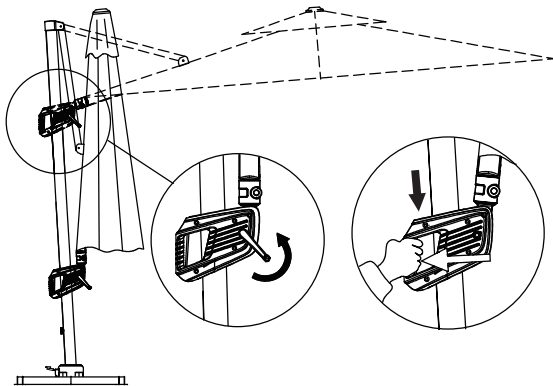

STEP 2

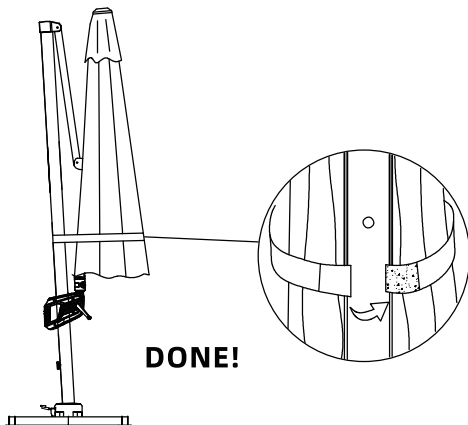

WARRANTY

- Bluu offers a 1-year basic warranty on ENTIRE UMBRELLA from the date of purchase against defects in material and workmanship. During this period Bluu will repair or replace, at our discretion, the defective component.
- This warranty does not apply to improperly installed, handled, abused, damaged by user error, nor to any unit which has been repaired or altered by unauthorized repair companies.
- Under no circumstances will the customer entitled warranty to consequential or incidental damages.
- This limited 1-year basic warranty will only grant customers certain legal rights; Customers may have other rights according to different state laws.
- **For warranty extension on other parts (if any), e.g. canopy fabric, please refer to the product page in the corresponding purchase channel for more information.**

THANK YOU FOR SHOPPING WITH US!

If you have any questions, or need assistance with use, parts, or customer service.

Please contact: **support@bluu.com**
Or text us messages at **(888) 363-2297**.

To help us identify your order, please include your Order #. Our professional team will be there to assist you.

Customer Service Team

bluu.com



Please scan the QR code
for more Bluu products.

