

PART #	DESCRIPTION
56103	05-UP TACOMA REAR AIR BUMP SYSTEM

COMPONENTS INCLUDED	
(2) 204902 2.0 AIR BUMP 2.5 TRAVEL 1:1 (1) 154015 BUMP STOP MOUNT (PASS) (1) 154016 BUMP STOP MOUNT (DRVR)	(2) 154018 BUMP STOP STRIKER PLATE (1) 56103H HARDWARE KIT
HARDWARE INCLUDED	
56103H HARDWARE KIT	
(2) 209000 SLEEVE 2.25 X 2.010 X .630 (4) 605052 1/4-20 NYLOCK NUT (4) 605057 1/4-20 X 2.000 SCREW (8) 605202 7/16-14 X 1.250 SCREW	(8) 605220 7/16-14 NYLOCK NUT (16) 605230 7/16 SAE FLAT WASHER (2) 605970 VIBRATITE ANTI SEIZE TUBE
TOOLS REQUIRED	
JACK JACK STANDS GRINDER W/ CUT-OFF WHEEL AIR CHISEL	1/4" SOCKET / WRENCH 5/8" SOCKET / WRENCH 7/16" SOCKET / WRENCH TORQUE WRENCH
TECH NOTES	
<p>1. FAILURE TO INSTALL BUMP STOP SPACER SLEEVE IF LEAF SPRING PACK IS LESS THAN 2.75" TALL MAY RESULT IN SHOCK AND/OR FRAME DAMAGE.</p> <p>2. APPLY ANTISEIZE TO THE BUMP STOP CYLINDER BEFORE INSERTING INTO THE BRACKET. FAILURE TO APPLY ANTISEIZE MAY CAUSE BUMP STOP TO GET STUCK IN THE BRACKET.</p> <p>3. IF USING A U-BOLT FLIP KIT, ICON STRIKER PLATE (56105) IS REQUIRED.</p> <p>4. YOUR ICON BUMP STOP ASSEMBLIES COME FACTORY CHARGED TO 100 PSI. PLEASE CONSULT ICON PRIOR TO MAKING ANY NITROGEN PRESSURE CHANGES.</p>	

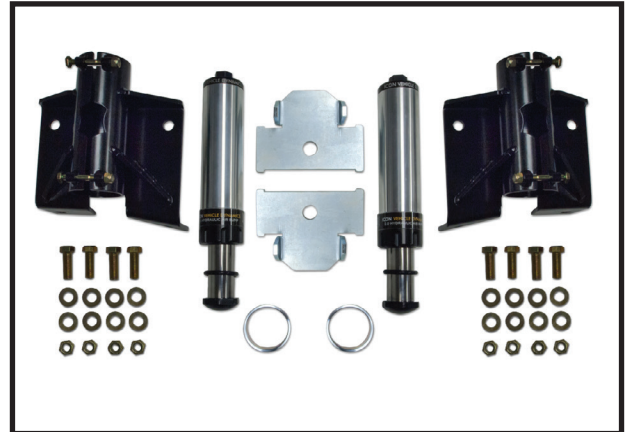

WARNING!
<p>** READ ALL INSTRUCTIONS THOROUGHLY FROM START TO FINISH BEFORE BEGINNING INSTALLATION! IF THESE INSTRUCTIONS ARE NOT PROPERLY FOLLOWED SEVERE FRAME, SUSPENSION AND TIRE DAMAGE MAY RESULT TO THE VEHICLE!</p> <p>** ICON VEHICLE DYNAMICS RECOMMENDS THAT YOU EXERCISE EXTREME CAUTION WHEN WORKING UNDER A VEHICLE THAT IS SUPPORTED WITH JACK STANDS.</p> <p>** ICON VEHICLE DYNAMICS RECOMMENDS ALL INSTALLTION TO BE PERFORMED BY A PROFESSIONAL SHOP/SERVICE TECHNICIAN. PRODUCT FAILURE CAUSED BY IMPROPER INSTALLATION WILL NOT BE COVERED UNDER ICON'S WARRANTY POLICY.</p>

INSTALLATION

- Using a properly rated jack, raise the rear of the vehicle and support the frame rails with jack stands. Ensure the jack stands are secure and set properly before lowering the jack. NEVER WORK UNDER AN UNSUPPORTED VEHICLE. Remove the front wheels.
- Remove the bump stop striker plate from the frame. There are 4 rivets attaching the striker plate to the frame that must be removed. The recommended rivet removing method is as follows although some people have other methods. Grind an "X" in the rivet head with a slitting disk. Using an air hammer or hammer and cold chisel shear the head off the rivet. Grind any exposed rivet shank as flush as possible. At this point you can start to pry the bracket to start to loosen it. Using a flat nose drift punch hammer the rivet out. If the rivet starts to expand in the hole and lock in you will have to center drill the rivet to release the pressure. [FIGURE 1 & 2]

FIG.1



FIG.2



- With the bracket removed position the new air bump bracket on the frame. It is designed to use the existing rivet holes. Bolt it to the frame using (4) 7/16 x 1.5" bolts, nuts and washers per side.
- Install the new striker plate on leaf spring. Support the axle with a jack. Remove the u-bolts and remove the stock rubber bump stop. If you are doing a leaf pack install in conjunction with the bump stops you can do that at this time. Position the striker plate on top of the leaf pack with the lower support arms up against the side of the leaf pack and install new u-bolts. If you are using a u-bolt flip kit on your vehicle, please purchase the u-bolt flip kit striker plate (56105).
- Apply antiseize to the bump stop cylinder before sliding it into the bracket.

6. Install the hydraulic air bump. Install the 1/4" bolts and nuts in the bump bracket pinch rings but do not tighten. Slide the 5/8" long spacer ring on the bump stop and slide the bump stop up into the bracket. Tighten the pinch bolts to retain the bump stop. If you are using a leaf pack assembly that is thicker than 2.75" the 5/8" spacer ring can be removed to get full up travel of the suspension. Removing the bump stop spacer with a leaf spring pack that is thinner than 2.75" will result in shock and/or frame damage.

7. Reinstall the wheels and lower the vehicle back to the ground. [Torque to factory spec]

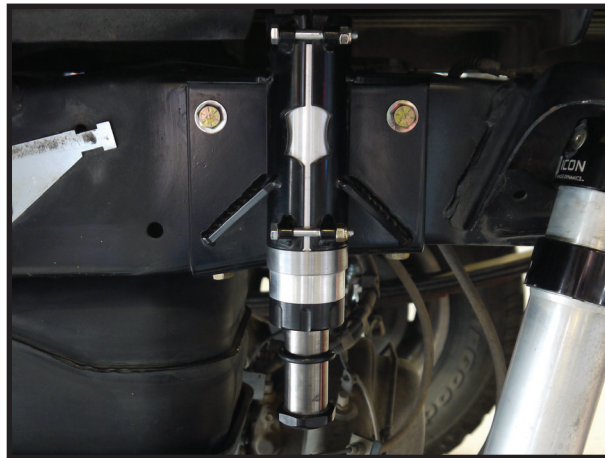

VERIFY ALL FASTENERS ARE PROPERLY TORQUED BEFORE DRIVING VEHICLE.

RETORQUE ALL NUTS, BOLTS AND LUGS AFTER 100 MILES AND PERIODICALLY THEREAFTER.

ICON VEHICLE DYNAMICS LIMITED LIFETIME WARRANTY

ICON Vehicle Dynamics warrants to the original retail purchaser who owns the vehicle on which the product was originally installed. ICON Vehicle Dynamics does not warrant the product for finish, alterations, modifications and/or installation contrary to ICON Vehicle Dynamics instructions. ICON Vehicle Dynamics products are not designed, nor are they intended to be installed on vehicles used in race applications, for racing purposes or for similar activities. (A "race" is defined as any contest between two or more vehicles, or a contest of one or more vehicles against the clock, whether or not such contest is for a prize). This warranty does not include coverage for police or taxi vehicles, race vehicles, or vehicles used for government or commercial purposes. Also excluded from this warranty are sales outside of the United States of America and Canada.

ICON Vehicle Dynamics' obligation under this warranty is limited to the repair or replacement, at ICON Vehicle Dynamics' discretion, of the defective product. Any and all costs of removal, installation or re-installation, freight charges and incidental or consequential damages are expressly excluded from this warranty. Items that are subject to wear are not considered defective when worn and are not covered.

ICON Vehicle Dynamics components must be installed as a complete kit as shown in our current application guide. Any substitutions or exemptions of required components will immediately void the warranty. Some finish damage may happen to parts during shipping and is not covered under warranty.

This warranty is expressly in lieu of all other warranties expressed or implied. This warranty shall not apply to any product that has been improperly installed, modified or customized subject to accident, negligence, abuse or misuse.

ICON VEHICLE DYNAMICS
PERFORMANCE SUSPENSION SYSTEMS AND SHOCK ABSORBERS

2.0 ALUMINUM SERIES TECHNICAL INFORMATION

MAINTENANCE

ICON shock absorbers are a high quality rebuildable race style shock absorber designed for optimal performance. With a unit of this caliber on your vehicle, routine maintenance is required to keep them looking and operating in like new condition. Residual oil and assembly lube may be present at all seal paths from the factory out of the box and is considered normal. Pooling of oil however is not acceptable at any time and one should contact the ICON dealer where purchased.

BELOW ARE GUIDELINES BASED ON HOW YOU USE YOUR VEHICLE BUT YOUR MILEAGE MAY VARY:

STREET USE:

- Send in for factory servicing every 40,000 miles or if a leak develops, ride quality decreases, or they begin to make excessive noise.
- Remove any buildup of road salt, mud, or debris from shocks anytime accrued
- Clean with mild soap and water with each oil change or anytime you notice build up.
- Wax the cylinders yearly with automotive wax to prevent corrosion.
- Check nitrogen pressure yearly. (252004 charge needle assembly available at any ICON distributor)

STREET/DIRT:

- Send in for factory servicing every 15,000 miles or if a leak develops, ride quality decreases, or they begin to make excessive noise.
- Clean with mild soap and water with each oil change, offroad trip, or anytime you notice build up.
- Wax the cylinders yearly with automotive wax to prevent corrosion.
- Check nitrogen pressure each dirt outing. (252004 charge needle assembly available at any ICON distributor)

DIRT USE:

- Send in for factory servicing every 1,000 miles.
- Check nitrogen pressure each outing. (252004 charge needle assembly available at any ICON distributor)
- Remove any buildup of mud or debris from shocks after every outing.

ICON VEHICLE DYNAMICS SHOCK ABSORBER WARRANTY

This shock absorber has a 1 year warranty against any manufacturer's defects. If a shock fails within the initial year of ownership, the shock must be shipped to ICON Vehicle Dynamics for inspection and service. If a shock is inspected and it has been determined the shock failed due to neglect, damage caused by improper installation or any other reason besides "normal wear and tear", the owner of said shock is responsible for all service costs. This includes labor, parts, and shipping.

ICON Vehicle Dynamics warrants to the original retail purchaser who owns the vehicle on which the product was originally installed. ICON Vehicle Dynamics does not warrant the product for finish, alterations, modifications and/or installation contrary to ICON Vehicle Dynamics instructions. ICON Vehicle Dynamics products are not designed, nor are they intended to be installed on vehicles used in race applications, for racing purposes or for similar activities. (A "race" is defined as any contest between two or more vehicles, or a contest of one or more vehicles against the clock, whether or not such contest is for a prize). This warranty does not include coverage for police or taxi vehicles, race vehicles, or vehicles used for government or commercial purposes. Also excluded from this warranty are sales outside of the United States of America and Canada.

ICON Vehicle Dynamics' obligation under this warranty is limited to the repair or replacement, at ICON Vehicle Dynamics' discretion, of the defective product. Any and all costs of removal, installation or re-installation, freight charges and incidental or consequential damages are expressly excluded from this warranty. Items that are subject to wear are not considered defective when worn and are not covered.

ICON Vehicle Dynamics components must be installed as a complete kit as shown in our current application guide. Any substitutions or exemptions of required components will immediately void the warranty. Some finish damage may happen to parts during shipping and is not covered under warranty.

This warranty is expressly in lieu of all other warranties expressed or implied. This warranty shall not apply to any product that has been improperly installed, modified or customized subject to accident, negligence, abuse or misuse.