

# XD3-30500-DC

## DMX Decoder/Driver

### Product Features

- Operates in DMX Slave or Master configuration.
- Easy to assign DMX address using LED display.
- Master mode has 8 static and 10 dynamic scenes.
- DMX status indicator confirms signal reception.
- 12-24VDC input voltage.
- 3-Channel output, 5A per channel.

### Product Specifications

• Input Voltage Range	12-24VDC
• Max. Load Current	5A per channel x 3 channels
• Max. Output Power	12V: 180W; 24V: 360W
• Grayscale Levels	4096
• Input Signal	DMX512/1990 digital signal
• Output Signal	Constant Voltage, PWM
• Channels	3
• DMX512 Connection	Terminal Block
• Operating Temperature	0 - 50°C
• Product Dimensions	(L)176 x (W)46 x (H)30 (mm); 6.93 x 1.81 x 1.18 (inch)
• Weight	170grams

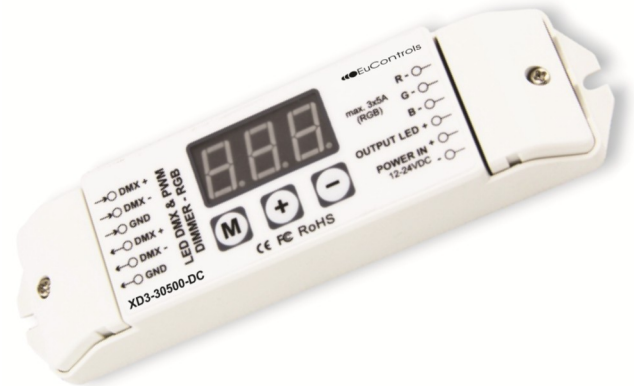

### Dimensions

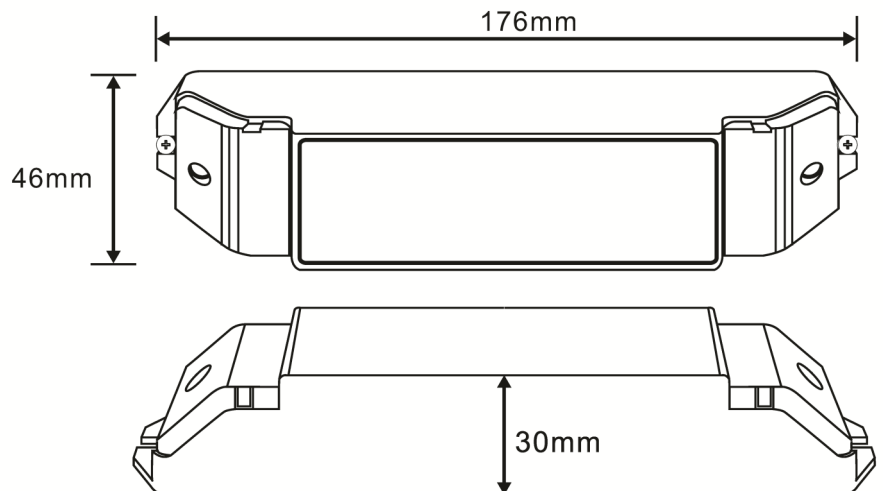

## XD3-30500-DC

### DMX Decoder/Driver

### Applications

Please review the entire user manual and consult with local electrical codes prior to installation. This decoder/driver can only be used with constant voltage LED lights.

In Slave mode, the decoder interprets the DMX512 signal and converts it to a PWM (Pulse with Modulation) signal used to control the LED lights.

The decoder/driver can also operate without DMX input as a stand-alone Master controller with Slave decoder/drivers.

### Safety Warnings

1. Please consult with local electrical codes and inspectors prior to installation.
2. Do not install near high voltage lines or strong magnetic fields.
3. Check all wiring connections to ensure polarity and avoid a short circuit prior to powering on.
4. Installation should be in a dry well ventilated area. Not for wet or damp locations.
5. 12-24VDC constant voltage power supply is required.
6. The power supply wattage should match or exceed the load of the LED lights.

### Operating Instructions

3 Touch buttons: M, +, -

M	Select display digit
+	Increase
-	Decrease

- The 3 LED display indicates DMX addresses (001 to 512) or preprogrammed modes (513 to 999).
- The display turns off after 1 minute of no activity. Press any key to re-activate.
- The decoder will automatically shut off if overload or short circuit is detected; the display will read "ERR".



#### Note:

The decoder has an automatic key lock. If no setting changes are made to the decoder, the key lock function is automatically activated after approximately 15 seconds. Pressing the "M" button for about 2 seconds will deactivate the key lock.

## XD3-30500-DC

### DMX Decoder/Driver

### Operating Instructions (Cont.)

- DMX Slave Mode:**

The value is 001 to 512. For example, 001.



**Note:** The decimal point behind the last digit will blink when receiving a normal DMX512 signal. If no signal is received, the address will be blank.

- DMX Master Mode (Static and dynamic scenes):**

000	Set all channels to 100%	520-529	Red, orange, yellow, green, cyan, blue, magenta (Fading Mode)
513	Red	530-539	White, magenta, red, orange, yellow, green, cyan, blue (Fading Mode)
514	Blue	540-549	Magenta, red (Fading Mode)
515	Green	550-559	Green, yellow (Fading Mode)
516	Yellow	560-569	Blue, green (Fading Mode)
517	Cyan	570-579	Magenta, blue (Fading Mode)
518	Pink	580-589	All 3 channels make a pulsating move from 1% to 100% (Fading Mode)
519	Magenta	590-599	Strobe all 3 channels from 0% to 100% (Jumping Mode)
		600-699	Blue to white from 0% to 99%
		700-799	Yellow to white from 0% to 99%
		800-899	Red to green from 0% to 99%
		900-999	10 different white tones mixing with different RGB percentage

**Note:**

- 520-599: The first two digits indicate the modes, the third indicates the speed. There are a total of 10 speed levels. 0 is the highest speed, and 9 is the lowest speed. There are total 8 modes. For example,

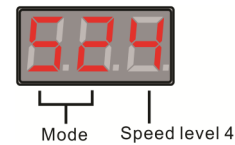

- Speed for Program 520-589 (Color Changing Fading Mode) for one step and not for the entire program:

0=0, 5 sec.	1=1 sec.	2=2 sec.	3=3 sec.	4=5 sec.	5=10 sec.	6=15 sec.	7=30 sec.	8=60 sec.	9=120 sec.
-------------	----------	----------	----------	----------	-----------	-----------	-----------	-----------	------------

- Speed for Program 590 - 599 (One step and not for the entire program):

0=0.02 sec.	1=0.04 sec.	2=0.1 sec.	3=0.2 sec.	4=0.5 sec.	5=1 sec.	6=2 sec.	7=5 sec.	8=10 sec.	9=15 sec.
-------------	-------------	------------	------------	------------	----------	----------	----------	-----------	-----------

- Brightness for 900 - 999. The digits show the brightness:

0=1%	1=5%	2=10%	3=20%	4=30%	5=40%	6=50%	7=60%	8=80%	9=100%
------	------	-------	-------	-------	-------	-------	-------	-------	--------

## XD3-30500-DC DMX Decoder/Driver

### Wiring Configurations

#### • Master Mode:

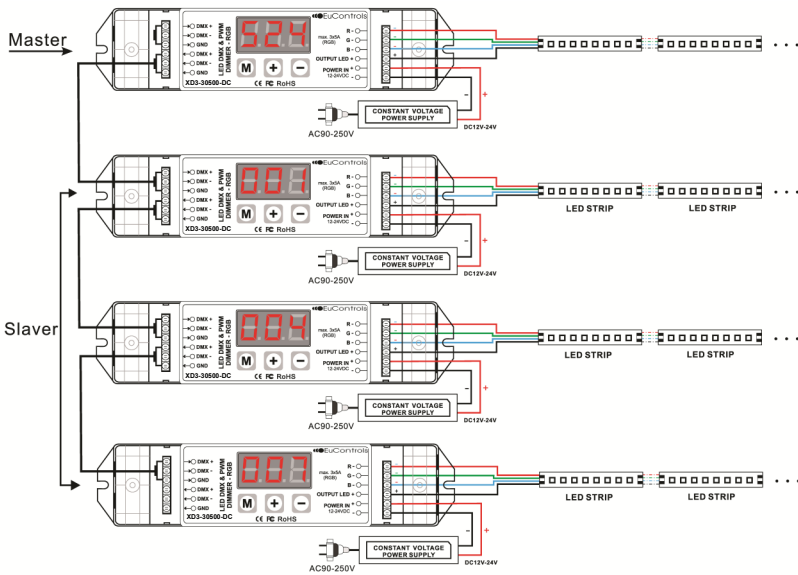

#### • Slave Mode:

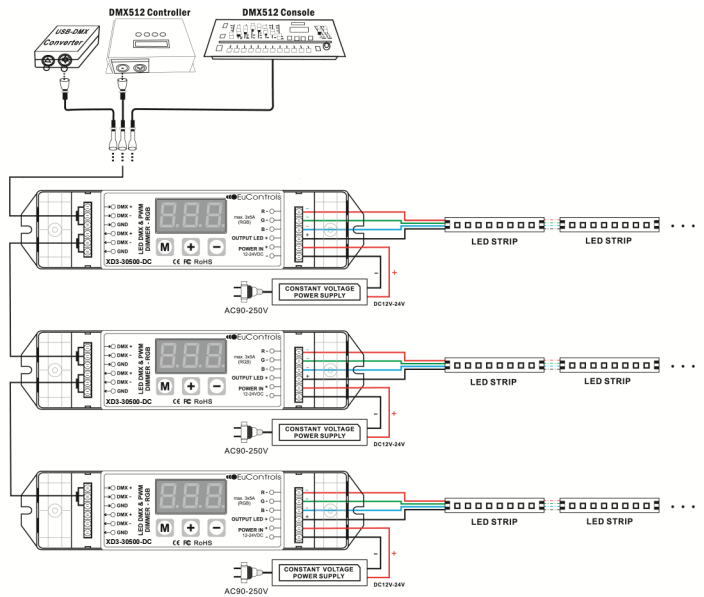

### Troubleshooting Guides

Problem	Reason	Solution
No Light (s)	No power	Check power supply and wiring
	Reversed polarity	Check wiring
	Signal terminal not connected or reversed	Check wiring
	Long circuit	Add DMX signal terminator or use amplifier
Wrong color (s)	Wrong RGB wiring	Check wiring
	Wrong decoder address entered	Enter the correct address
1 or more colors are lit, but no change	Signal terminator has wrong connection or reversed	Check wiring
	Long circuit	Add DMX signal terminator or use amplifier
Abnormal flickering	Signal terminator has wrong connection	Check wiring
	Long circuit	Add DMX signal transmitter or use amplifier