

INSTALLATION & OPERATION MANUAL



What's in the box?



XC3-20500-RF
WW+CW LED Controller
w/ RF Remote Control



EULSC0230-5.0
Single Density Cool White
LED Strip Lighting (16'4" ft)



EULSW0230-5.0
Single Density Warm White
LED Strip Lighting (16'4" ft)



EUPS10012
100W UL Listed AC/DC 12V Power Supply



2 × **EUABCON-W10**
4 × **EUECON-W10**
Butt & End-to-End Connectors

SYSTEM OVERVIEW

Thanks for purchasing the EUKT06-CWWW30 LED Strip Lighting System, designed for indirect lighting applications. Every installation is unique, and lighting effects can depend on personal preference. Installation location, surfaces, wall colors, mounting angle, and obstacles can all affect lighting appearance.



This package includes a professional Cool + Warm White LED controller with wireless RF remote, a 100W UL listed AC/DC power supply, and two 16'4" foot reels of LED strip lighting containing Cool White and Warm White LED modules, respectively. The XC3-20500-RF controller is used to control both Cool White and Warm White LED strip lighting simultaneously, allowing for color blends between approximately 3000-7000 K. The controller is typically mounted out of the way, and the touch-sensitive RF remote is used to select from a range of colors from warm to cool white. All shades of white are dimmable and have eight adjustable levels of brightness. There are also remote keys for instant access to 100% Cool White and 100% Warm White.

Before installing this LED lighting system, please consider your desired layout configuration:

1. Location of the power supply and LED controller
2. Wire connections to your LED strips
3. Adhesive strip mounting surface and run length



Please check your local electrical safety codes prior to beginning your project. All wiring must comply with local and national electrical codes for Class II lighting. The 12V DC output circuits that are part of this LED lighting system meet Class II lighting requirements and are safe for DIY installation. Any alterations or wiring modifications (i.e. hardwiring) to the 120V AC input power supply should be completed by a licensed electrician. In some cases, you may need to splice connecting wires to power the LED strips or make extended turns. Again, if you are unclear as to how to install this system, please consult a licensed electrician, and they can help turn your lighting idea into reality.





BEFORE YOU GET STARTED

Please keep in mind the following precautions before installation:

- Disconnect the AC/DC power supply BEFORE making cuts or connections.
- Do NOT install or use this system in wet or damp locations. The included parts are rated for indoor use ONLY (IP20 NEMA rating).
- Use LED strip lighting ONLY with a low-voltage 12V DC power source and compatible 12/24V DC Controller.
- ALWAYS observe the B-/V+ indicators on the LED strip lighting in order to maintain polarity.
- When running wires inside walls, use ONLY properly certified CL2 (Class II) or better cabling. Do NOT install Class II low voltage wiring in the same runs with AC mains power wiring. If AC and DC wires cross, keep at 90° angle.
- Do NOT operate the LED strip lights while they are coiled on the plastic reel. Excessive heat from LED operation may cause the reel to melt.
- To protect your eyes, do NOT look directly at the LEDs while they are lit.



CONTROLLER I/O WIRING DETAILS

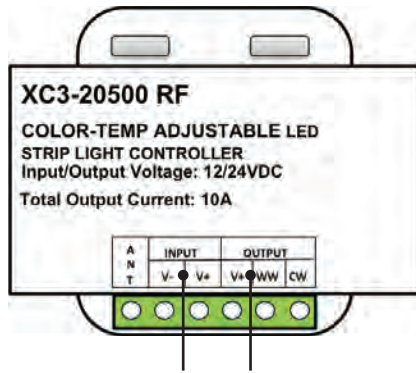

INPUT FROM POWER SUPPLY
 12/24V DC Power Supply required.
 Power to load. Maintain polarity.

OUTPUT TO LED STRIPS
 Connect two separate CW and WW
 strips or a single CW+WW strip.

V+ = Hot Wire (Red)
 V- = Common (Black or White)
 ANT = [Not Used]

V+ = Hot Wire (Red)
 WW = Common (Black or White)
 CW = Common (Black or White)



EXAMPLE LAYOUT CONFIGURATIONS

Using 2 LED Strips: 1 Warm White + 1 Cool White

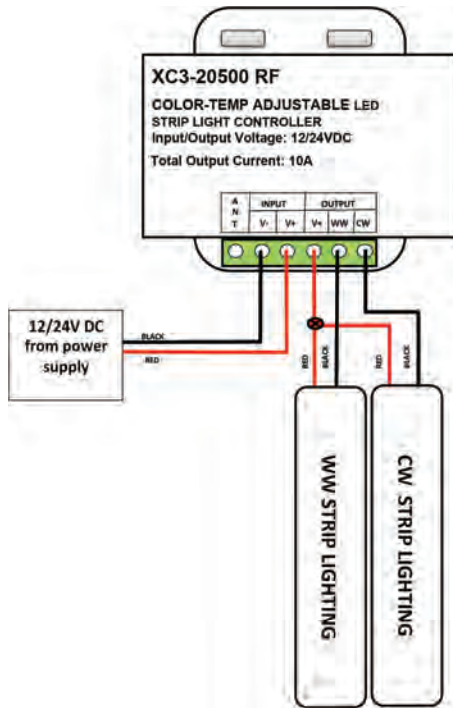

Using 1 CW+WW LED Strip

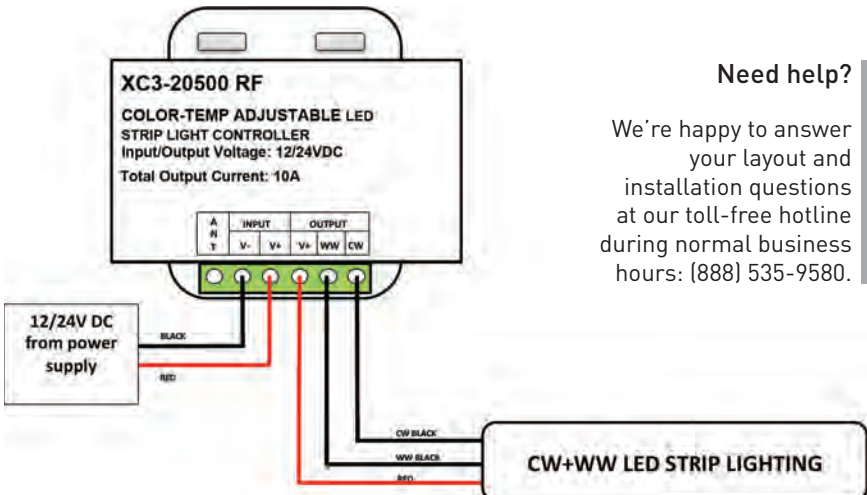

Need help?

We're happy to answer your layout and installation questions at our toll-free hotline during normal business hours: (888) 535-9580.



LED STRIP INSTALLATION

Cutting & Connecting LED Strips

To divide a 16'4" reel of Cool or Warm White LED strip lighting into smaller sections for shorter runs, cut and join shorter strands using the included connectors.



Butt Connectors are ideal for immediate, straight connections between strips.



End-to-End Connectors allow connections around corners and at oblique angles.

1. Locate the cut line on the Cool or Warm White LED strip (RGB version strip shown in photos).
2. Using only sharp scissors, cut evenly across the solder pads at an exact angle 90° degrees to the LED strip.
3. Unlatch the lids on both ends of a Butt or End-to-End Connector and insert the LED strip completely into one side's groove, guiding the strip UNDER the plastic guard edges so that the copper pads are positioned BENEATH the connector pins. Repeat for the second LED strip on the other side of the connector.
4. Snap both connector lids down to tightly close the connector. Before proceeding with mounting and final installation, power on and test the LED strip layout to verify proper connections and correct LED operation.
5. To use one half of an End-to-End Connector for splices, you must observe the V-/V+ indicators on the LED strip in order to establish correct wiring.

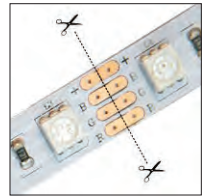

Mounting the LED Strips

1. First, ensure that the mounting surface area is clean. The area should be free from oil or waxes and should be smooth and dry to allow proper adhesion of the 3M adhesive tape on the LED strip lighting's back side.
2. Plan a clear, straight path for a strip run. Avoid sharply bending or twisting the LED strip at curves, as this could damage the LED modules and their connections.
3. Gently remove the backing from the 3M adhesive side and press sections of the strip between the LED modules to securely contact the surface of the mounting surface. Avoid pressing on individual LED modules, as this could also damage their solder connections to the strip.





CONTROLLER OPERATION

Operation via RF Remote Control

100% COOL WHITE MODE BUTTON

Use to change to Cool White only with full dimming ability.

100% WARM WHITE MODE BUTTON

Use to change to Warm White only with full dimming ability.

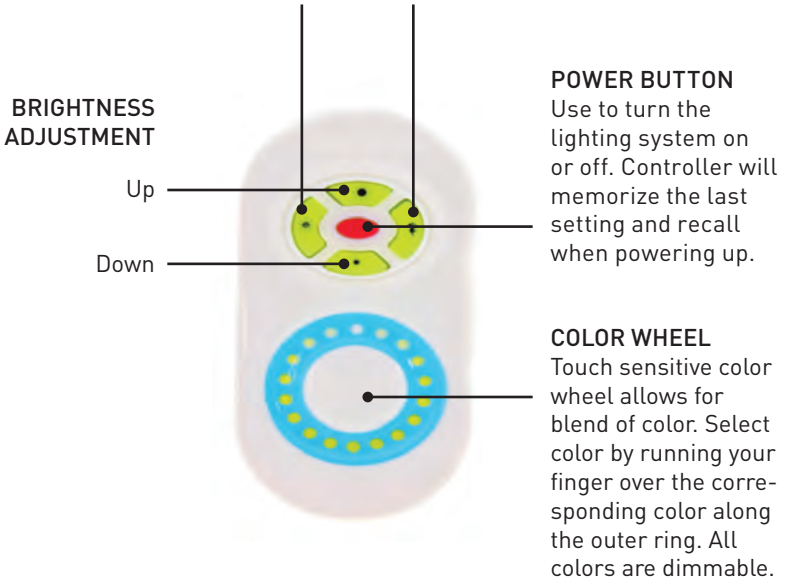

REMOTE CONTROL SYNC

Each RF remote control has a unique ID code and an operation range of about 65 feet. A single remote can be synchronized with up to 20 controllers. The power-off memory function will retain the last sync and mode upon powering up again.

HOW TO SYNC: Turn on the controller, then press and hold the BRIGHT+ button for 3 seconds. If successful, connected LED lights will blink 3 times.

HOW TO CLEAR THE SYNC: Turn on the controller, then press the BRIGHT+ button 6 times within 3 seconds. If successful, connected LED lights will blink 6 times.

BATTERY INSTALLATION

The remote control requires 3 AAA batteries. Do not touch the color wheel or press any button during installation. Wait 3 seconds after installation to use the remote. Re-install the batteries if the color wheel or buttons are unresponsive.



CONTROLLER SPECIFICATIONS

Input Voltage 12/24V DC
Channels 2 (WW+CW)
Current Load 5 A max × 2 channels
Output Power 240W max (24V DC)
Operating Temp. -35° to 55° C
RF Control Range Up to 65 feet

Controller Size 65 x 64 x 24 mm (LWH)
Remote Size 114 x 55 x 21 mm (LWH)
Remote Type RF touch temp wheel
Brightness Adj. 8 levels of dimming
Built in Modes 100% Warm/Cool White
Memory Function Power Off/On



TROUBLESHOOTING GUIDE

PROBLEM	REASON	SOLUTION
Connected lights not working	Wire connection issue	Check WW and CW connections. V+ is the red wire on White LEDs strips.
	Power issue	Check the power supply output and power cord connections.
Wrong colors	Wire connection issue	Check WW and CW connections. Reverse if necessary.
Remote not working	Battery or distance issue	Check polarity of batteries, re-install, and move closer to the controller.
Remote responds slowly	Battery issue	Batteries are low on charge. Replace them with fresh ones.
Abnormal flicker	Voltage drop issue	Increase the wire gauge between connections.
	Power issue	Not enough power. Make sure your power supply is adequate for the load.
	Signal loss	Add repeaters and power supplies based on the load of the strips as necessary.
Signal corruption	Interference issue	Clear ID code on remote and re-sync.

THREE YEAR LIMITED PRODUCT WARRANTY

PRODUCT WARRANTY EuControls Corporation ("EuControls") warrants that at the time of shipment, the standard products manufactured by EuControls, and sold hereunder, will be free from defects in material and workmanship for a period of three (3) years from the date of shipment.

WARRANTY ADJUSTMENT Buyer shall notify EuControls immediately if any defect within the warranty period should appear. EuControls agrees to repair or furnish a replacement for, but not install, any product which within three (3) years from the date of shipment by EuControls, shall upon examination by EuControls, prove defective within the above warranty period. No product will be accepted for return or replacement without written authorization of EuControls. Upon such authorization, and in accordance with instructions by EuControls, the product will be returned shipping charge prepaid by Buyer. Replacements made under this warranty will be shipped prepaid by Seller.

EXCLUSIONS FROM WARRANTY This warranty does not extend to any products manufactured by EuControls which has been subjected to misuse, neglect, accident, improper installation or use in violation of instructions furnished by EuControls. This warranty does not extend to, or apply to, any unit which has been repaired or altered other than at EuControls' factory, or by persons not expressly approved by EuControls. Components purchased or made by Buyer from any supplier other than EuControls shall bear only the warranty given by the manufacturer of that product, and EuControls assumes no responsibility for the interface of its product with any other product, and such responsibility shall remain with Buyer for interface, functionality, and intended use.

NOTICE The foregoing warranty is in lieu of and excludes all other expressed or implied warranties of merchantability or fitness for use or otherwise.



EuControls Corp.
19210 S Vermont Ave, Bldg C
Gardena, CA 90248
United States

Toll-Free: (888) 535-9580
Tel: (310) 643-5700
Fax: (310) 643-5688

