

Service Manual

Air Conditioner

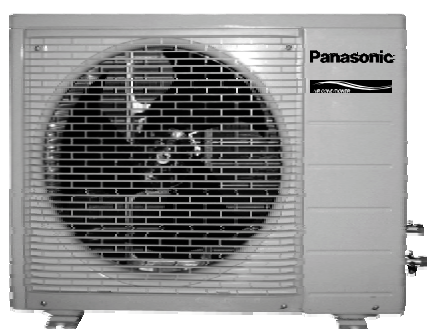

CS/CU-PC9GKV CS/CU-PC12GKV

WARNING

This service information is designed for experienced repair technicians only and is not designed for use by the general public. It does not contain warnings or cautions to advise non-technical individuals of potential dangers in attempting to service a product. Products powered by electricity should be serviced or repaired only by experienced professional technicians. Any attempt to service or repair the product or products dealt with in this service information by anyone else could result in serious injury or death.

CONTENTS

	Page		Page
1 Features	2	10 2-way,3-way Valve	31
2 Functions	3	11 Disassembly of The Parts	38
3 Product Specifications	6	12 Troubleshooting Guide	41
4 Dimensions	10	13 Technical Data	43
5 Refrigeration Cycle Diagram	12	14 Exploded View	44
6 Block Diagram	13	15 Replacement Parts List	45
7 Wiring Diagram	14	16 Exploded View	46
8 Operation Details	15	17 Replacement Parts List	47
9 Installation	21		

Panasonic®

© Panasonic Home Appliances Air Conditioner (Guangzhou) Co., Ltd. (PHA-AG) All rights reserved. Unauthorized copying and distribution is violation of law.

1 Features

- High Efficiency

- Auto Restart Control

Radom auto restart after power failure

- Comfort Environment

Air filter with function to reduce dust and smoke

- 12-hour Timer Setting

2 Functions

Remote Control

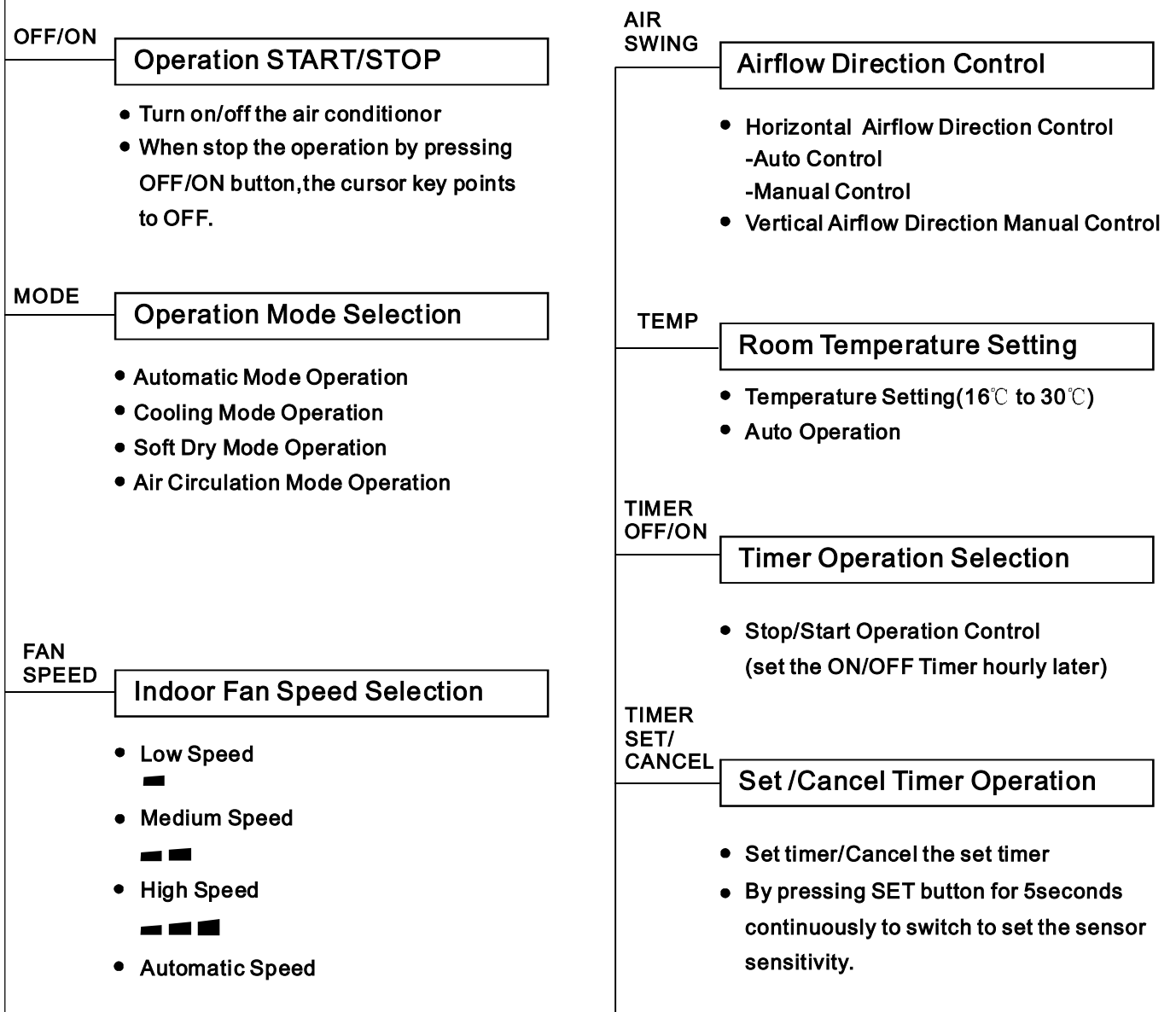
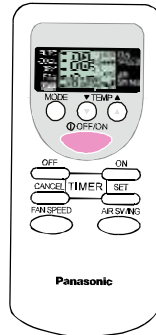

Indoor Unit



Auto Switch Button

Power Switch ON/OFF

- When the remote control cannot be used or for repairing and testing ,please use this button.

Signal Receiving Sound Control

- Keep pressing this button for 10seconds to turn on or turn off the signal receiving sound.

Auto Restart Control

- Keep pressing this button for 15seconds to switch off Auto Restart Control. To resume Auto Restart Control,repeat the above step.

Operation Indication Lamps

- Power (green)Lights up in operation; Blinks during Test Run operation and determining Auto Operation mode
- Timer(orange)Timer in operation
- Air quality { Green
Orange
Red

Operation Mode

- Cooling/Soft Dry /Auto Operation/ Air circulation

Time Delay Safety Control

- The unit will restart operation in 3-4 minutes after each pause.

7-Minutes Time Save Control

- 7-minutes automatic restarting at Cooling Operation

Anti-freezing Control for the Evaporator

- Cooling or Soft Dry Operation

Indoor Fan Speed Control

- High,Med,Low
- Auto Fan Speed

Airflow Direction Control

- Automatic Airflow Direction Control
The louver automatically swings up and down
- Airflow Direction Manual Control

Delayed On-timer Control

- For cooling or soft dry mode, the unit starts 15 minutes before the set time with the remote control.

Outdoor Unit

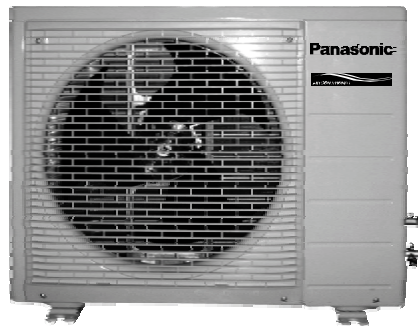

Anti-reverse Protection

- To protect the compressor from reverse rotation when power off suddenly.

Overload Protector



- The 2-step Overload Protector is to protect the compressor when
 - 1)Temperature of compressor reaches 165°C for PC9GKV or 148°C for PC12GKV.
 - 2)High temperature or current enters into the compressor

60-seconds Test Operation Control

- Once the compressor is activated, it does not stop for 60 seconds. It stops immediately with remote control ON/OFF button.

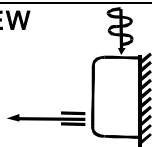
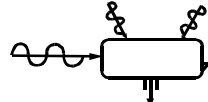
3 Product Specifications

		Unit	CS-PC9GKV	CU-PC9GKV	
Cooling Capacity		kW	2.50-2.50		
Moisture Removal		L/h	1.4		
Power Source		Phase V Cycle	Single 220/230 60		
Airflow Method		OUTLET → INTAKE ←	SIDE VIEW 	TOP VIEW 	
Air Circulation	Indoor Air (low)	m ³ /min	7.2	-	
	Indoor Air (medium)	m ³ /min	8.1	-	
	Indoor Air (high)	m ³ /min	9.3	-	
	Outdoor Air	m ³ /min	-	-	
Noise Level		dB(A)	High36,Low30	High49	
Electrical Data	Input	W	830-840		
	Running Current	A	4.00-3.90		
	EER	W/W	3.01-2.97		
	Starting Current	A	19.0		
Piping Connection Port(Flare piping)		Inch inch	G:half union3/8" L:half union1/4"	G:3-way valve3/8" L:2-way valve1/4"	
Piping Size(Flare piping)		Inch inch	G:gas side3/8" L:liquid side1/4"	G:gas side3/8" L:liquid side1/4"	
Drain Hose	Inner Diameter	mm	15.5	-	
	Length	m	0.5	-	
Power Supply Cord Length (Number of core-wire)		m	1.8 3 core-wire/1.0mm ²	- -	
Dimensions	Height	mm	250	530	
	Width	mm	770	650	
	Depth	mm	205	230	
Net Weight		kg	7.5	23	
Compressor	Type		-	Rotary(1 cylinder) Rolling piston type	
	Motor Type		-	Induction(2 pole)	
	Rated Output	W	-	650	
Air Circulation	Type		Cross-flow fan	Propeller fan	
	Motor Type		Induction(4 pole)	Induction(6pole)	
	Input	W	48.3	82.2	
	Rated Output	W	13	28	
	Fan Speed	Low	rpm	870±60	-
		Med	rpm	980±60	-
High		rpm	1130±60	840±60	

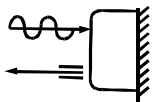
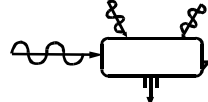
		Unit	CS-PC12GKV	CU-PC12GKV	
Cooling Capacity		kW	3.50-3.50		
Moisture Removal		L/h	2.1		
Power Source		Phase V Cycle	Single 220/230 60		
Airflow Method		OUTLET  INTAKE 	SIDE VIEW 	TOP VIEW 	
Air Circulation	Indoor Air (low)	m ³ /min	8.1	-	
	Indoor Air (medium)	m ³ /min	9.2	-	
	Indoor Air (high)	m ³ /min	10.1	-	
	Outdoor Air	m ³ /min	-	-	
Noise Level		dB(A)	High39,Low33	High49	
Electrical Data	Input	W	1210-1220		
	Running Current	A	5.70-5.50		
	EER	W/W	2.89-2.86		
	Starting Current	A	25.0		
Piping Connection Port(Flare piping)		Inch inch	G:half union1/2" L:half union1/4"	G:3-way valve1/2" L:2-way valve1/4"	
Piping Size(Flare piping)		Inch inch	G:gas side1/2" L:liquid side1/4"	G:gas side1/2" L:liquid side1/4"	
Drain Hose	Inner Diameter	mm	15.5	-	
	Length	m	0.5	-	
Power Supply Cord Length (Number of core-wire)		m	1.8 3 core-wire/1.0mm ²	- -	
Dimensions	Height	mm	250	530	
	Width	mm	770	650	
	Depth	mm	205	230	
Net Weight		kg	7.5	27	
Compressor	Type		-	Rotary(1 cylinder) Rolling piston type	
	Motor Type		-	Induction(2 pole)	
	Rated Output	W	-	1100	
Air Circulation	Type		Cross-flow fan	Propeller fan	
	Motor Type		Induction(4 pole)	Induction(6pole)	
	Input	W	48.3	82.2	
	Rated Output	W	16	28	
	Fan Speed	Low	rpm	1030±60	-
		Med	rpm	1160±60	-
		High	rpm	1280±60	840±60

		Unit	CS-PC12GKV	CU-PC12GKV
Heat Exchanger	Description		Evaporator	Condenser
	Tube Material		copper	copper
	Fin Type		slot type	Corrugation type
	Rows/Stage		(Plate fin configuration,forced draft)	
	FPI		2 x 12	2 x 24
	Dimensions	mm	610x252x25.4	578 X504x25.4 558
Refrigerant Control Device			-	Capillary Tube
Refrigeration Oil		(c.c)	-	SUNISO 4GDID or ATMOS M60(M56)
Refrigerant (R-22)		g	-	910(*)
Thermostat			Electronic Control	O.L.P.(30A/230V)
Protection Device			-	
Capillary	Length	mm	-	655±20
	Circulation	L/min	-	9.5±0.2
	Inner Diameter	mm	-	1.5
Air Filter			P.P Honeycomb	-
Refrigerant Circulation Control Device			Capillary	
Compressor Capacitor		μF , V	-	30μF , 370V
Fan Motor Capacitor		μF , V	1.5μF , 400V	2.0μF , 440V

* 60g for air purging is not included.

- Specifications are subject to change without notice for further improvement.

2 Dimensions

Indoor Unit

CS-PC9GKV / CS-PC12GKV

Unit : mm

Top view

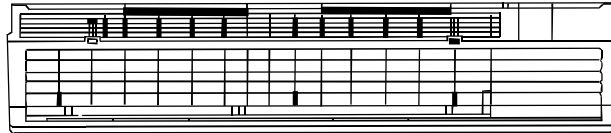

Side view

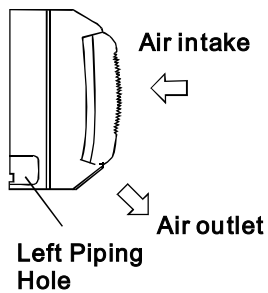

Front View

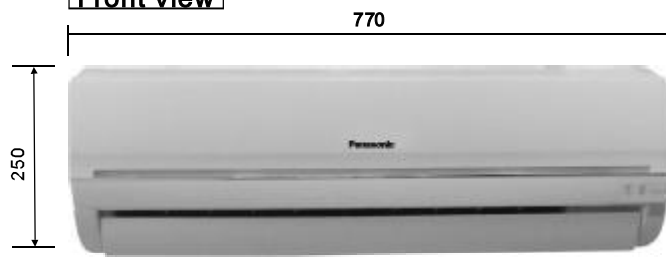

Side view

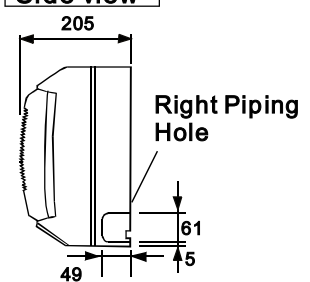

Bottom Piping Hole

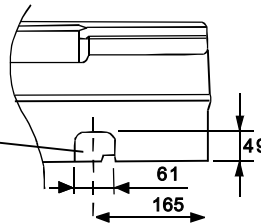

Back View

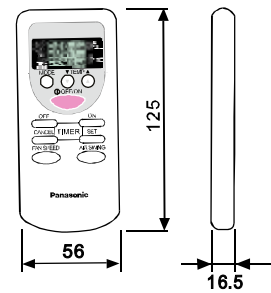
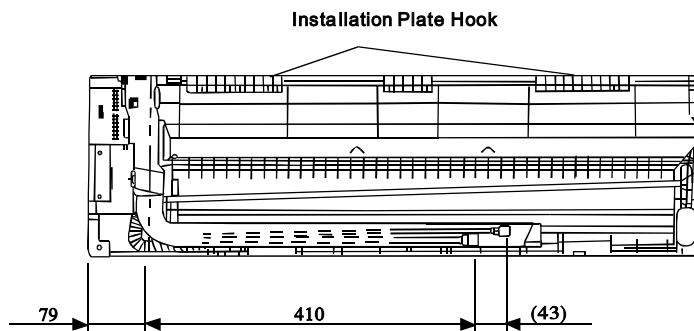

Dimension of installation plate (Front View)

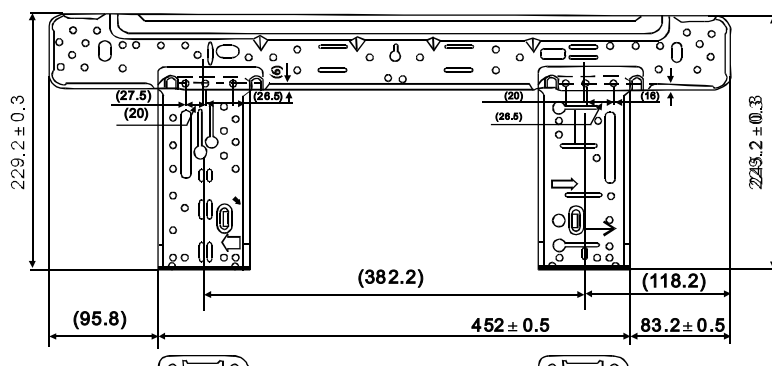

Outdoor Unit

CU-PC9GKV
CU-PC12GKV

Unit : mm

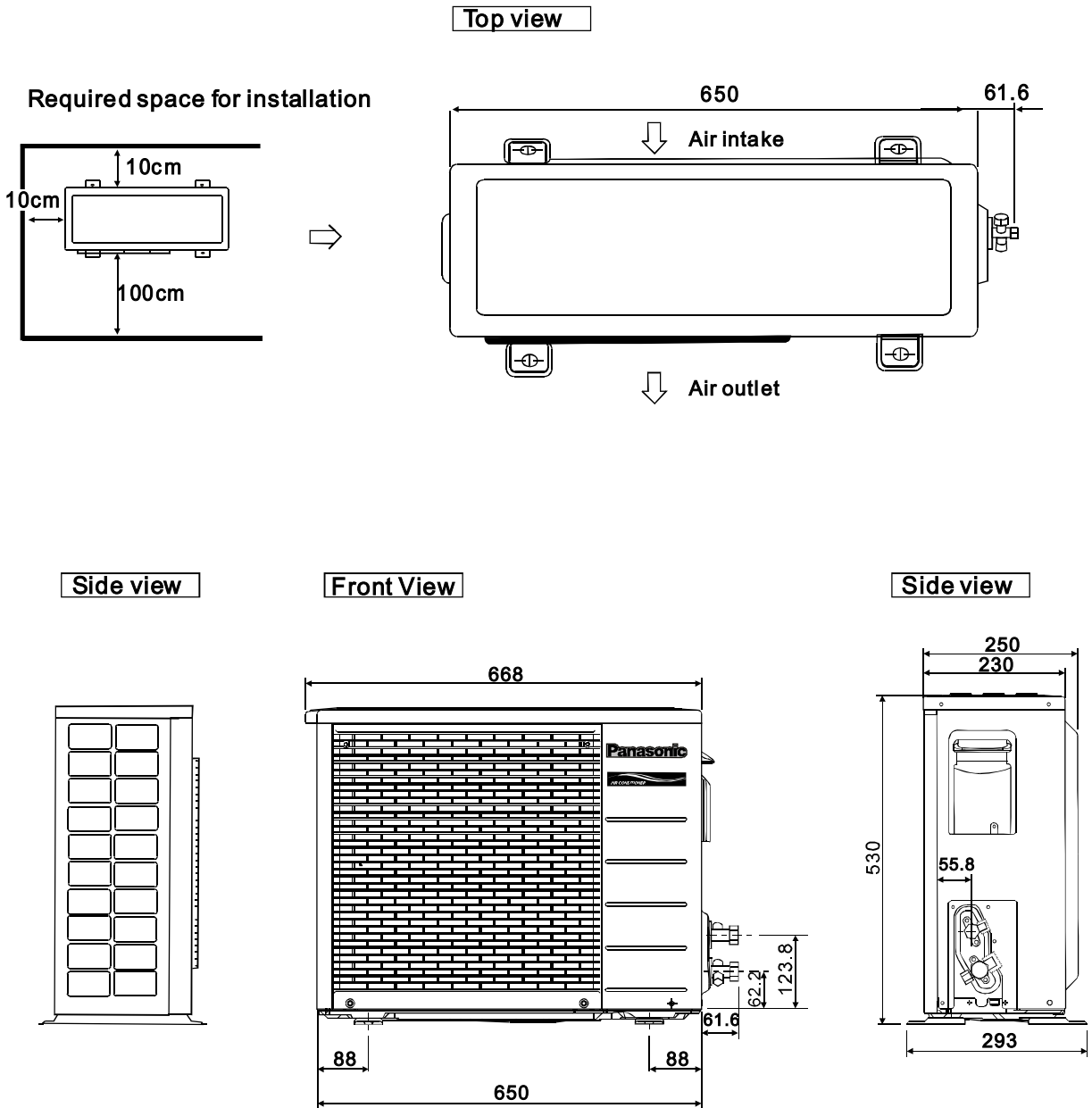

5 Refrigeration Cycle Diagram

CS/CU-PC9GKV
CS/CU-PC12GKV

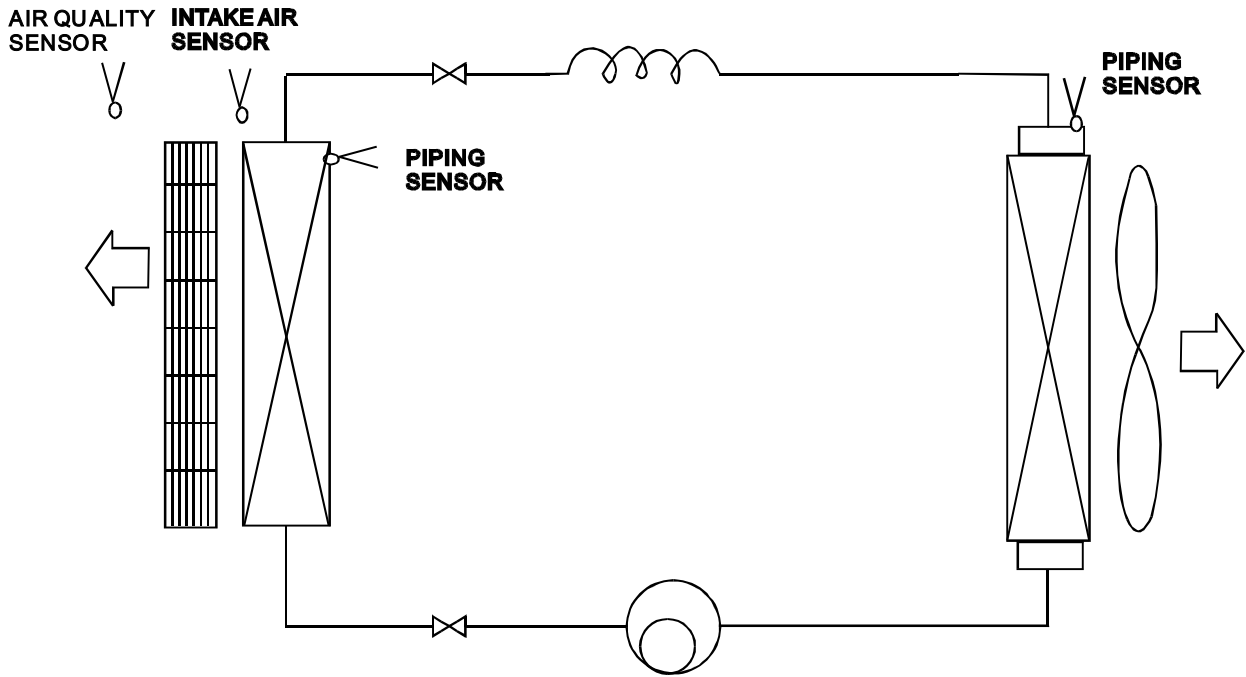

6 Block Diagram

CS-PC9GKV/CU-PC9GKV
 CS-PC12GKV/CU-PC12GKV

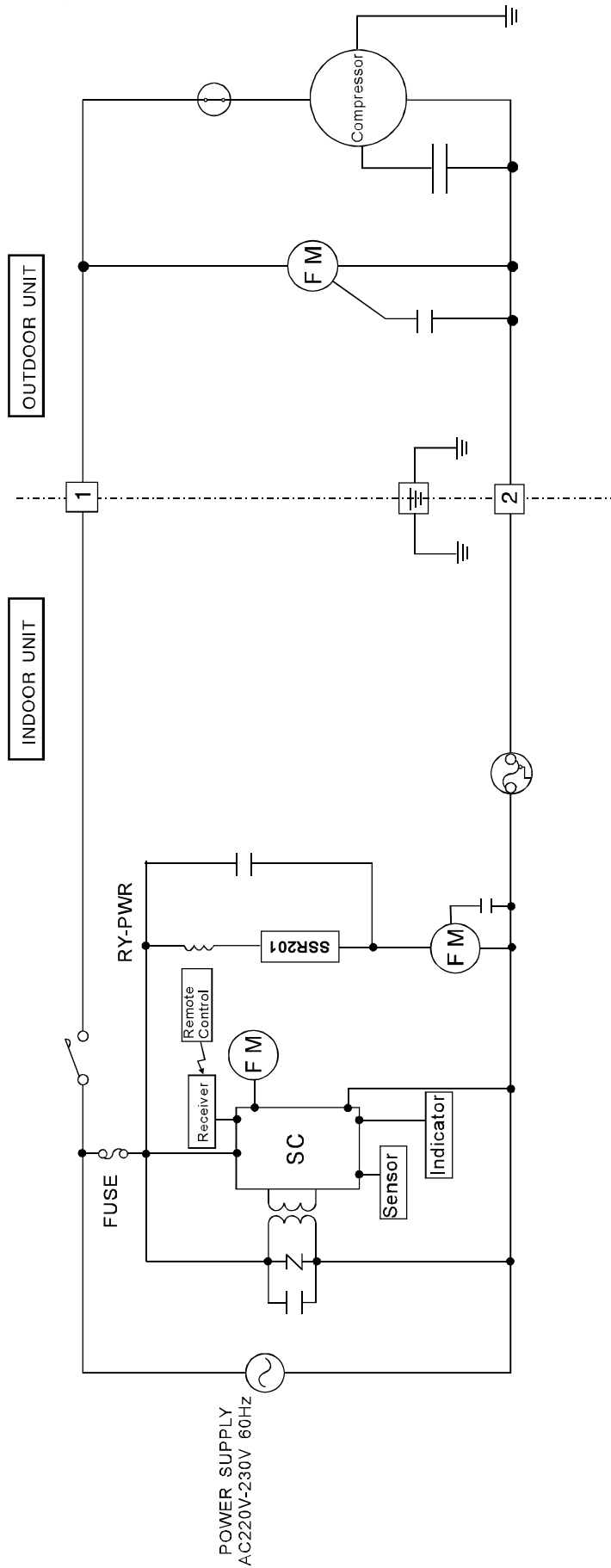

7 Wiring Diagram

CS-PC9GKV/CU-PC9GKV CS-PC12GKV/CU-PC12GKV

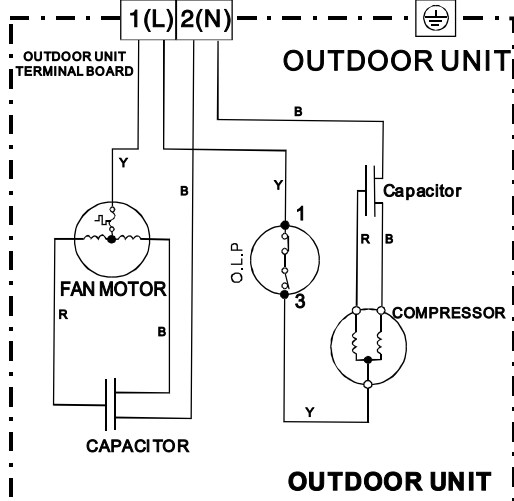
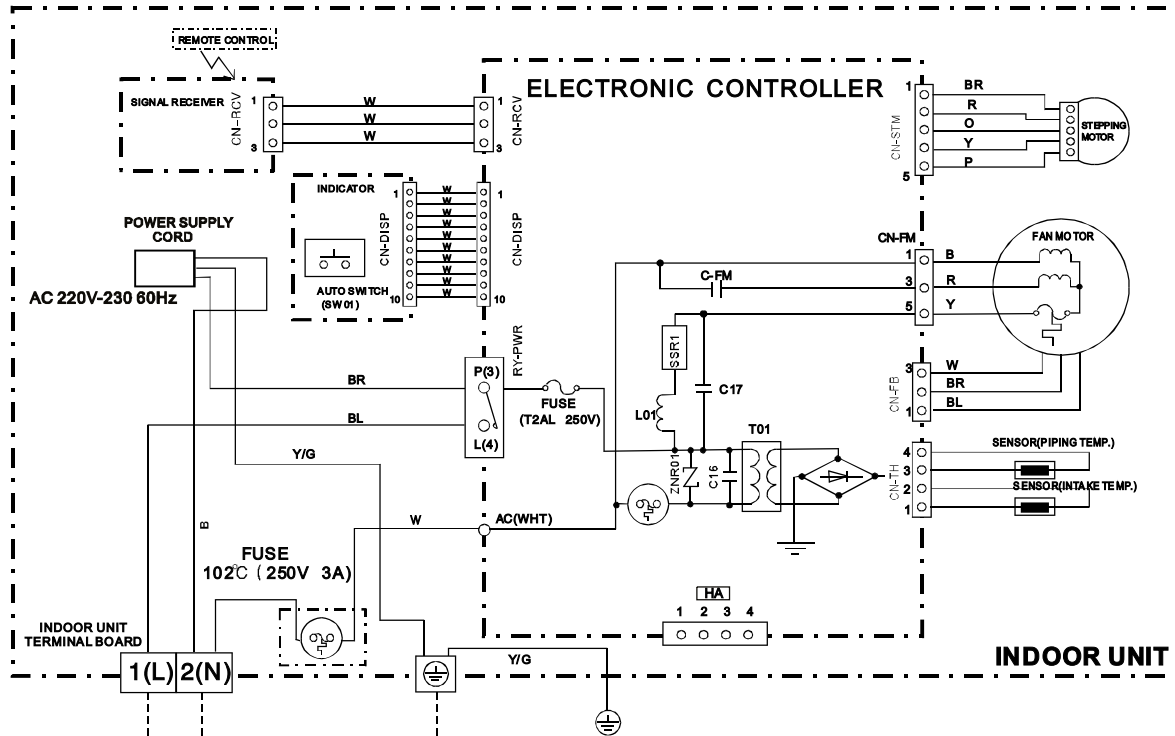

- R : RED
- BL : BLACK
- B : BLUE
- BR : BROWN
- O : ORANGE
- GRY : GREY
- G : GREEN
- Y : YELLOW
- W : WHITE
- Y/G : YELLOW/GREEN

INDOOR FAN MOTOR RESISTANCE(Ω)

	CS-PC9GKV	CS-PC12GKV
CONNECTING	CWA921310	CWA921310
Y-B (M)	395	395
Y-R (A)	240	240

OUTDOOR FAN MOTOR RESISTANCE(Ω)

	CU-PC9GKV	CU-PC12GKV
CONNECTING	CWA951374	CWA951374
Y-B	309	309
Y-R	252	252

COMPRESSOR RESISTANCE(Ω)

	CU-PC9GKV	CU-PC12GKV
CONNECTING	CWB092308	CWB092309
C - R	1.681	2.237
C - S	2.764	2.710

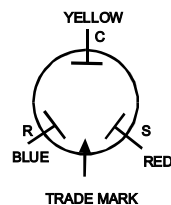
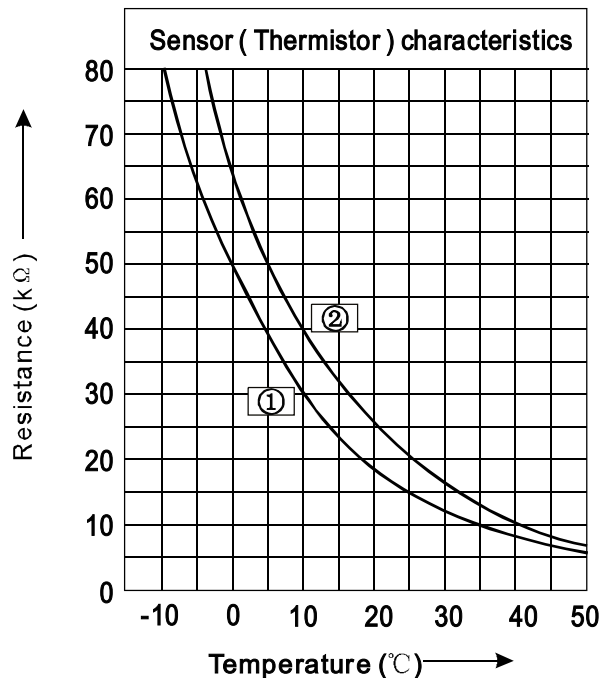

COMPRESSOR TERMINAL

8 Operation Details

8.1 Cooling Mode Operation.

When selecting the Cooling Mode Operation, the unit will operate according to the setting by the Remote Controller or the control panel on the indoor unit and the operation is as the following.

Time Delay Safety Control

- 3 min.----If the compressor stops, it will not restart within 3 minutes.(Protection of compressor).

7 Minutes Time Save Control

- 7 min.----The unit will automatically operate in 7 minutes even if the room temperature is not reached. (Prevention of raising the humidity)

Anti-Freezing Control

- If temperature of evaporator is lower than 2°C continuously for 4 minutes, the compressor will cease to prevent the evaporator from freezing. Fan speed setting will not be changed.
- When temperature of evaporator reaches 10°C, compressor will restart.

※ During Cooling Mode Operation, the Time Delay Safety Control is available.

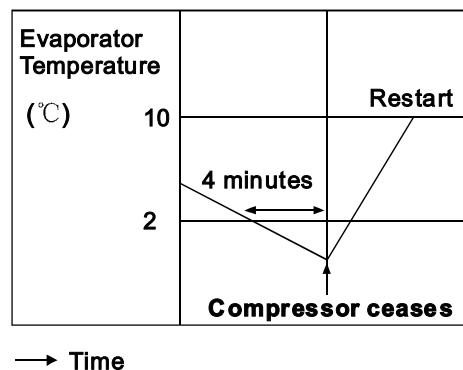

Automatic Fan Speed Mode

During Cooling Mode Operation, use remote controller to select Automatic Fan Speed.

- Fan speed will be at the point between "High speed" and "Medium speed".
- Deodorization control.

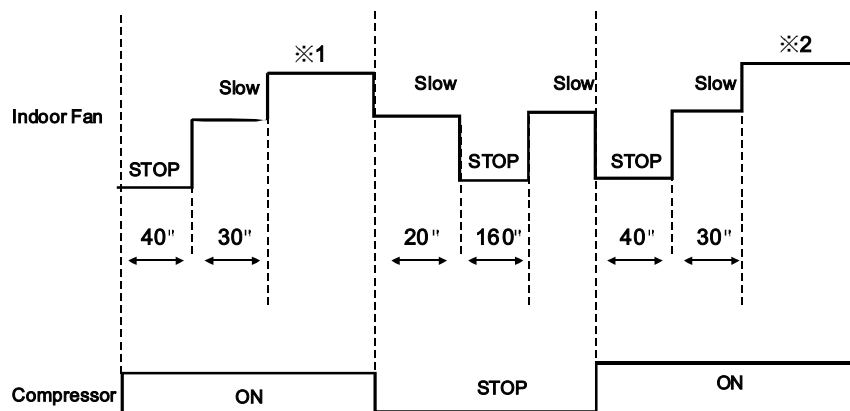

- ※ 1 Fan speed will be at "Hi" till the compressor ceases (set temperature reached).
- ※ 2 Fan speed will be at "Me" when the compressor restarts.

Automatic Fan Speed

- During Soft Dry Operation, use remote controller to select Auto Fan Speed mode. Indoor Fan Speed is at "Lo-"

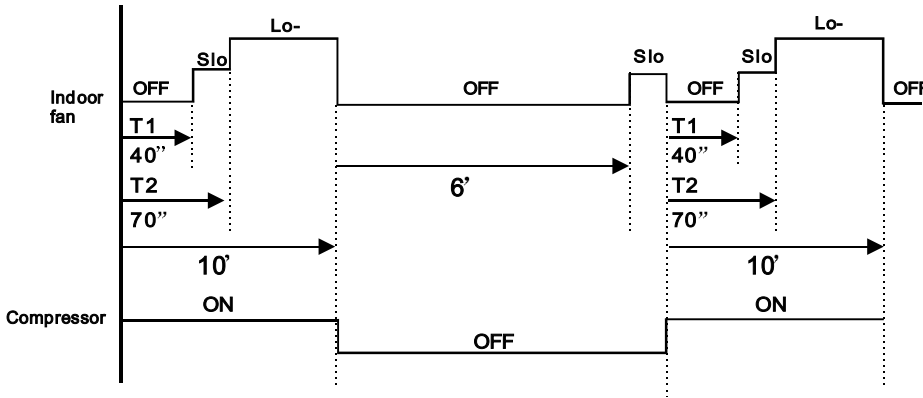

Time Graph for soft dry operation

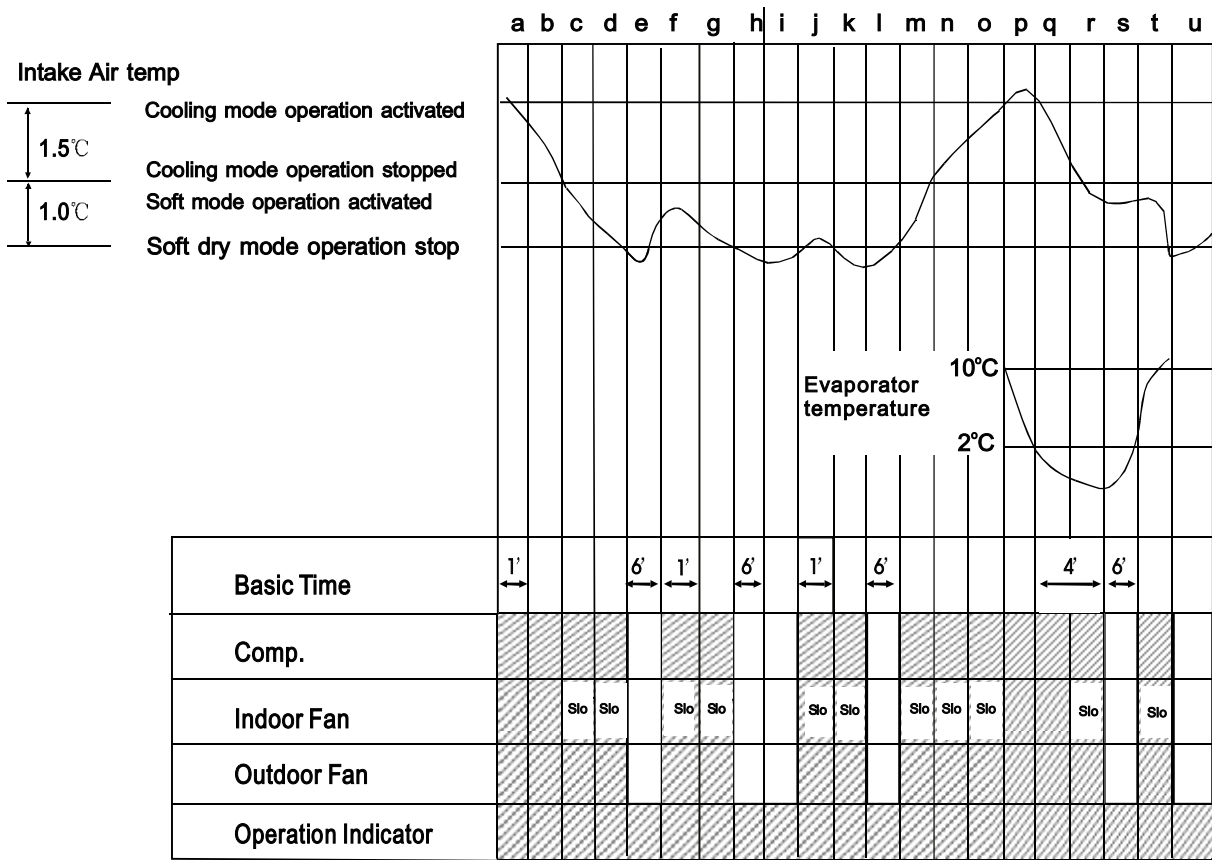

→ Time

〈Operation status〉

- a-c, p-r : Cooling Mode Operation
- c-p, r-u : Soft Dry Mode Operation
- e-f : Soft Dry Mode Operation Stopped
- j-l : Compressor Test Operation Control
- q-t : Anti Freezing Control

- Cooling mode operation
- - - Soft Dry Mode operation
- ▨ Operate
- Stop

8.3. Automatic Mode Operation

Standard for Determining Operation Mode

● **First Determination:**

Intake Air temperature 23°C	Cooling mode	Setting Temperature (Standard)
	Soft Dry mode	
	Cooling mode	25°C
	Soft Dry mode	22°C

● **Second Determination:**

One hour after the above determination, the unit will operate according to the table below.

		Second Determination	
		Cooling	Dry
First determination	Cooling	23°C or above	————
	Dry	————	20°C or above

- A) Indoor fan operates at super low speed for 25 seconds.
- B) After judging indoor air temperature, the operation is determined and operation continued at the mode determined.
- C) After the operation mode has been determined, the mode does not change. However, Soft Dry mode operation includes cooling mode operation.
- D) If automatic mode operation is started while the unit is operating, operation will continue.
- E) If current operation is in cooling mode (including the cooling mode operation when is a part of Soft Dry mode operation) it will be maintained, and if current operation is not cooling mode, the appropriate operation mode is determined for 25seconds at super slow fan speed. Then the selected mode will continue.
- F) Room temperature adjustment

Higher	→	+ 2°C
Standard	→	± 0°C
Lower	→	- 2°C

8.4. Air Circulation Mode Operation

1. An additional heater may make the warm air evenly covering each corner of the room.
2. When the temperature near the ceiling reaches the setting temperature, Air Circulation Mode Operation commences at low airflow volume. It stops when the temperature drops to 2°C below the setting temperature.
3. The vertical airflow direction louver will not swing.

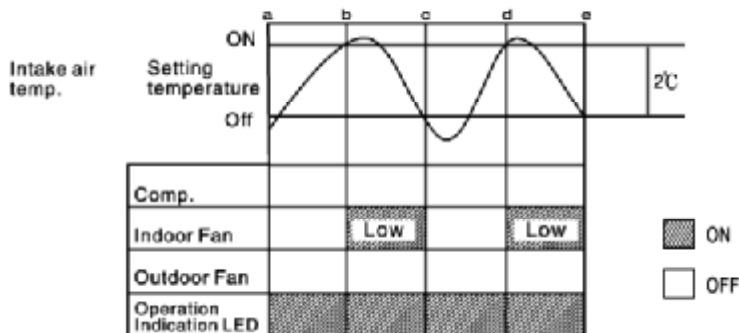

8.5 About Cursor Key Which Points To “OFF” On Remote Control

- When the ON/OFF button on the remote control is pressed, the cursor key which points to “OFF” will appear or disappear to indicate the ON/OFF status of the air conditioner.

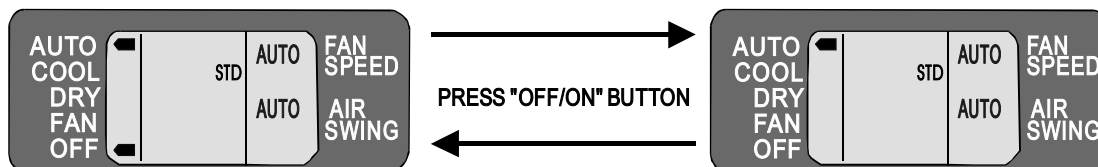

- For some reason (Ex. The signal of the remote control does not reach the signal receiver of the indoor unit.), the display of the remote control will not correspond with the actual ON/OFF status of the indoor unit:
 - The air conditioner is running but the cursor key which points to “OFF” appears. The air conditioner can be stopped with any button (Except for “ON/OFF”, “TIMER SET”, “TIMER ON”) pressed.
 - The air conditioner is on standby, but the cursor key which points to “OFF” disappears. The air conditioner can be started with any button (Except for “ON/OFF”, “TIMER SET”, “TIMER OFF”) pressed.

8.6. Indoor Fan Motor Control

- Automatic fan speed control
When automatic fan speed set, the available range for fan speed is from Hi to SLo.
- Manual Fan Speed Control
Basic fan speed can be manually adjusted (Lo, Med, Hi) by using the fan speed selection button.
- Basic Fan Speed

Category		Hi	Me	Lo	Lo-	SLo	SSLo
Cooling Mode Operation	Manual	○	○	○			
	Auto	○	○			○	
Soft Dry Operation	Manual				○	○	
	Auto				○	○	
Heating Mode Operation	Manual	○	○	○	○	○	○
	Auto		○	○	○	○	○

8.7. Auto restart control

- If the operation is stopped due to a power failure under any operation mode, it will restart automatically under the previous operation mode when the power supply is resumed.
- The Auto restart control can be switched off by pressing AUTO ON/OFF button for about 15 seconds until 3 “beep” sound is heard. To activate this type of control again, repeat the above step.

8.11. Airflow Direction Control





Airflow Direction Auto-control

- When set at airflow direction auto-control with remote control, the louver swings up and down as shown in the table below.
- The louver does not swing when the indoor fan stops during operation.
- When stop the unit with remote control, the discharge vent is closed with the louver.
- ※ The left and right airflow direction louver can be adjusted manually.

Airflow direction manual control

- When the airflow direction set button is pressed, the automatic airflow is released and the airflow direction louver moves up and down as shown in the table below. The louver can be stopped by releasing the button at the desired position.
- When the remote control is used to stop the operation, the discharge vent is closed with airflow direction louver.

Angles Of Airflow Direction Louver

Operating Mode		 1	 2	 3	 4	 5
Cooling Soft dry	Manual	12°	17°	26°	32°	36°
	Auto	12° ~36°				
Determining operation mode		9°				

Notes:

- In cooling or soft dry mode operation
If the compressor continues to operate for 60 minutes, and the louver direction is at No 5, the fan speed is below Med, the intake air temperature is below 29 °C and continues to change between 2 °C for 30 minutes, the louver direction will be at No 2 in order to prevent dew around the discharge vent.

9 Installation Instructions

Required tools for Installation Works			
1. Philips screw driver	5. Spanner	9. Gas leak detector	13. Multimeter
2. Level gauge	6. Pipe cutter	10. Measuring tape	14. Torque wrench 18 N.m (1.8 kgf.m) 42 N.m (4.2 kgf.m) 55 N.m (5.5 kgf.m)
3. Electric drill, hole core drill ($\varnothing 70$ mm)	7. Reamer	11. Thermometer	15. Vacuum pump
4. Hexagonal wrench (4 mm)	8. Knife	12. Megameter	16. Gauge manifold

9.1. Safety Precautions

- Read the following "SAFETY PRECAUTIONS" carefully before installation.
- Electrical work must be installed by a licensed electrician. Be sure to use the correct rating of the power plug and main circuit for the model to be installed.
- The caution items stated here must be followed because these important contents are related to safety. The meaning of each indication used is as below. Incorrect installation due to ignoring of the instruction will cause harm or damage, and the seriousness is classified by the following indications.



 WARNING	This indication shows the possibility of causing death or serious injury.
--	---

 CAUTION	This indication shows the possibility of causing injury or damage to properties only.
--	---

The items to be followed are classified by the symbols:

	Symbol with background white denotes item that is PROHIBITED from doing.
--	--

- Carry out test running to confirm that no abnormality occurs after the installation. Then, explain to user the operation, care and maintenance as stated in instructions. Please remind the customer to keep the operating instructions for future reference.

 WARNING	
1. Engage dealer or specialist for installation. If installation done by the user is defective, it will cause water leakage, electrical shock or fire.	
2. Install according to this installation instruction strictly. If installation is defective, it will cause water leakage, electrical shock or fire.	
3. Use the attached accessories parts and specified parts for installation. Otherwise, it will cause the set to fall, water leakage, fire or electrical shock.	
4. Install at a strong and firm location which is able to withstand the set's weight. If the strength is not enough or installation is not properly done, the set will drop and cause injury.	
5. For electrical work, follow the local national wiring standard, regulation and this installation instruction. An independent circuit and single outlet must be used. If electrical circuit capacity is not enough or defect found in electrical work, it will cause electrical shock or fire.	
6. Use the specified cable (1.5 mm ²) and connect tightly for indoor/outdoor connection. Connect tightly and clamp the cable so that no external force will be acted on the terminal. If connection or fixing is not perfect, it will cause heat-up or fire at the connection.	
7. Wire routing must be properly arranged so that control board cover is fixed properly. If control board cover is not fixed perfectly, it will cause heat-up at connection point of terminal, fire or electrical shock.	
8. When carrying out piping connection, take care not to let air substances other than the specified refrigerant go into refrigeration cycle. Otherwise, it will cause lower capacity, abnormal high pressure in the refrigeration cycle, explosion and injury.	
9. When connecting the piping, do not allow air or any substances other than the specified refrigerant (R22) to enter the refrigeration cycle. Otherwise, this may lower the capacity, cause abnormally high pressure in the refrigeration cycle, and possibly result in explosion and injury.	
10. Do not modify the length of the power supply cord or use of the extension cord, and do not share the single outlet with other electrical appliances. Otherwise, it will cause fire or electrical shock. if the power supply cord is damaged, engage an authorized dealer to replace it.	





CAUTION

1. The equipment must be earthed. It may cause electrical shock if grounding is not perfect.
2. Do not install the unit at place where leakage of flammable gas may occur. In case gas leaks and accumulates at surrounding of the unit, it may cause fire. 
3. Carry out drainage piping as mentioned in installation instructions. If drainage is not perfect, water may enter the room and damage the furniture.

ATTENTION

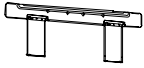
1. Selection of the installation location.
Select a installation location which is rigid and strong enough to support or hold the unit, and select a location for easy maintenance.
2. Power supply connection to the room air conditioner.
Connect the power supply cord of the room air conditioner to the mains using one of the following method.
Power supply point shall be the place where there is ease for access for the power disconnection in case of emergency.
In some countries, permanent connection of this room air conditioner to the power supply is prohibited.
 1. Power supply connection to the receptacle using a power plug.
Use an approved 10A power plug with earth pin for the connection to the socket.
 2. Power supply connection to a circuit breaker for the permanent connection. Use an approved 10A circuit breaker for the permanent connection. It must be a double pole switch with a minimum 3 mm contact gap.
3. Do not release refrigerant.
Do not release refrigerant during piping work for installation, reinstallation and during repairing a refrigeration parts. Take care of the liquid refrigerant, it may cause frostbite.
4. Installation work.
It may need two people to carry out the installation work.
5. Do not install this appliance in a laundry room or other location where water may drip from the ceiling, etc. 

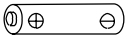
Attached accessories.

No.	Accessories part	Qty.
1	Installation plate 	1
2	Installation plate fixing screw 	5
3	Remote control 	1
4	Battery 	2

SELECT THE BEST LOCATION

INDOOR UNIT

- There should not be any heat source or steam near the unit.
- There should not be any obstacles blocking the air circulation.
- A place where air circulation in the room is good.
- A place where drainage can be easily done.
- A place where noise prevention is taken into consideration.
- Do not install the unit near the door way.
- Ensure the spaces indicated by arrows from the wall, ceiling, fence or other obstacles.
- Recommended installation height for indoor unit shall be at least 2.5 m.

OUTDOOR UNIT

- If an awning is built over the unit to prevent direct sunlight or rain, be careful that heat radiation from the condenser is not obstructed.
- There should not be any animal or plant which could be affected by hot air discharged.
- Keep the spaces indicated by arrows from wall, ceiling, fence or other obstacles.
- Do not place any obstacles which may cause a short circuit of the discharged air.
- If piping length is over the common length, additional refrigerant should be added as shown in the table.

Model	Piping size		Max. Elevation (m)	Max. Piping Length (m)	Additional Refrigerant (g/m)
	Gas	Liquid			
PC9GKV	3/8"	1/4"	5	7	-
PC12GKV	1/2"	1/4"	5	7	-

Indoor/Outdoor Unit Installation Diagram

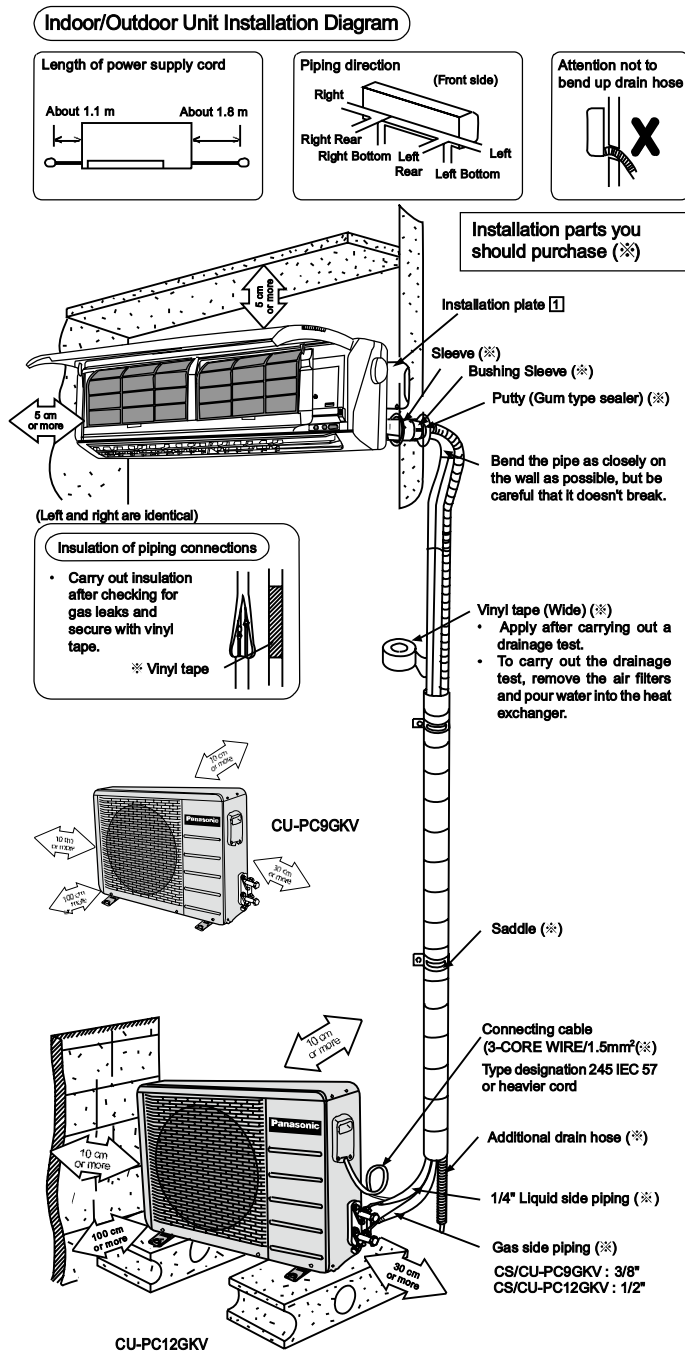

9.2. INDOOR UNIT

9.2.1. SELECT THE BEST LOCATION (Refer to "Select the best location" section)

9.2.2. HOW TO FIX INSTALLATION PLATE

The mounting wall is strong and solid enough to prevent it from the vibration.

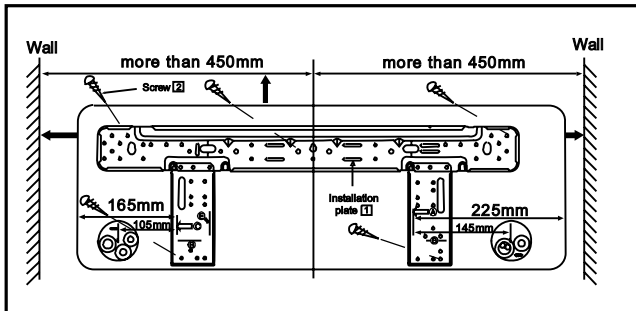

The centre of installation plate should be at more than 450 mm at right and left of the wall.

The distance from installation plate edge to ceiling should more than 67 mm.

From installation plate left edge to unit's left side is 62 mm.

From installation plate right edge to unit's right is 79 mm.

- Ⓔ : For left side piping, piping connection for liquid should be about 10 mm from this line.
- : For left side piping, piping connection for gas should be about 45 mm from this line.
- : For left side piping, piping connecting cable should be about 785 mm from this line.

1. Mount the installation plate on the wall with 5 screws or more.

(If mounting the unit on the concrete wall consider using anchor bolts.)

Always mount the installation plate horizontally by aligning the marking-off line with the thread and using a level gauge.

2. Drill the piping plate hole with $\varnothing 70$ mm hole-core drill.

Line according to the arrows marked on the lower left and right side of the installation plate. The meeting point of the extended line is the centre of the hole. Another method is by putting measuring tape at position as shown in the diagram above. The hole centre is obtained by measuring the distance namely 105 mm and 145 mm for left and right hole respectively.

Drill the piping hole at either the right or the left and the hole should be slightly slanted to the outdoor side.

9.2.3. TO DRILL A HOLE IN THE WALL AND INSTALL A SLEEVE OF PIPING

1. Insert the piping sleeve to the hole.
2. Fix the bushing to the sleeve.
3. Cut the sleeve until it extrudes about 15 mm from the wall.

Caution

When the wall is hollow, please be sure to use the sleeve for tube ass'y to prevent dangers caused by mice biting the connecting cable.

4. Finish by sealing the sleeve with putty or caulking compound at the final stage.

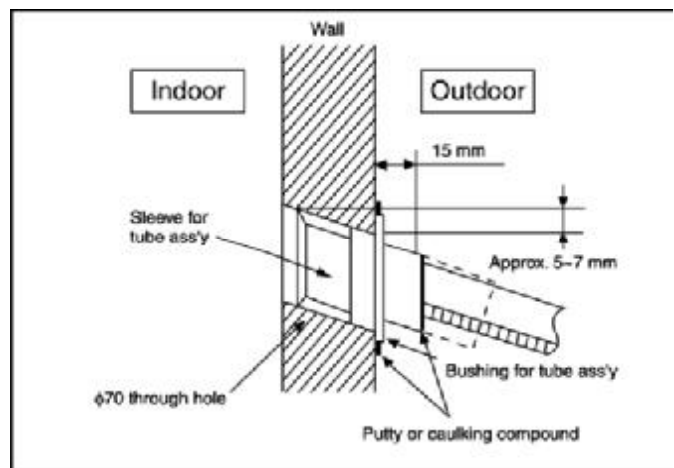

9.2.4. INDOOR UNIT INSTALLATION

1. For the right rear piping

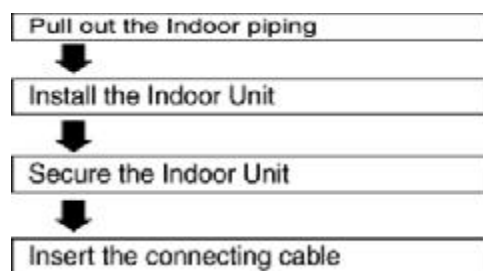

2. For the right and right bottom piping

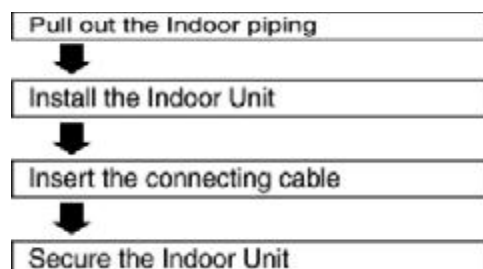

3. For the embedded piping

- Replace the drain hose**
- Bend the embedded piping**
 - Use a spring bender or equivalent to bend the piping so that the piping is not crushed.
- Install the Indoor Unit**
- Cut and flare the embedded piping**
 - When determining the dimension of the piping, slide the unit all the way to the left on the installation plate. Refer to the section "Cutting and flaring the piping".
- Pull the connecting cable into Indoor Unit**
 - The inside and outside connecting cable can be connected without removing the front grille.
- Connect the piping**
 - Please refer to "Connecting the piping" column in outdoor unit section. (Below steps are done after connecting the outdoor piping and gas-leakage confirmation.)
- Insulate and finish the piping**
 - Please refer to "Piping and finishing" column of outdoor section and "Insulation of piping connections" column as mentioned in Indoor/Outdoor Unit Installation.
- Secure the Indoor Unit**

Install the Indoor Unit

Hook the indoor unit onto the upper portion of installation plate (Engage the indoor unit with the upper edge of the installation plate). Ensure the hooks are properly seated on the installation plate by moving in left and right.

Secure the Indoor Unit

1. Tape the extra power supply cord in a bundle and keep it behind the chassis.
 - Ensure that the power supply cord is not clamped in between the unit's hook (2 positions) and installation plate.
2. Press the lower left and right side of the unit against the installation plate until hooks engages with their slots (sound click).

Pull out the piping and drain hose

To take out the unit, push the **PUSH** marking at the bottom unit, and pull it slightly towards you to disengage the hooks from the unit.

(This can be used for left rear piping & left bottom piping also.)

How to keep the cover

In case of the cover is cut, keep the cover at the rear of chassis as shown in the illustration for future reinstallation.

(Left, right and 2 bottom covers for piping)

Exchange the drain hose and the cap

Refer view for left piping installation

Adjust the piping slightly downwards

Insert the connecting cable

Length of connecting cable	Gas side piping	Liquid side piping
77 cm		
Cable		

- How to pull the piping and drain hose out, in case of the embedded piping.

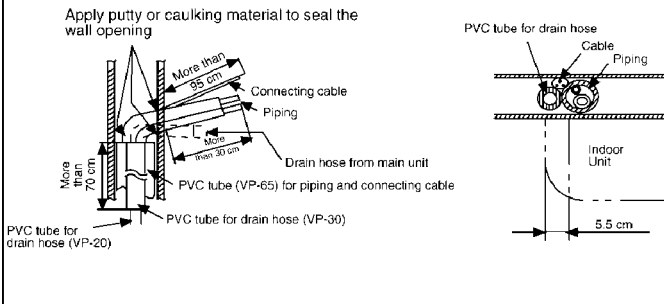

- In case of left piping how to insert the connecting cable and drain hose.

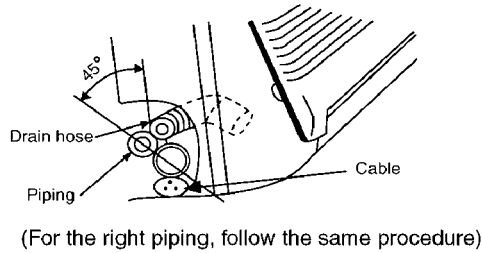

9.2.5. CONNECT THE CABLE TO THE INDOOR UNIT

1. The inside and outside connecting cable can be connected without removing the front grille.
2. Connecting cable between indoor unit and outdoor unit shall be approved polychloroprene sheathed 3 x 1.5 mm² flexible cord, type designation 245 IEC 57 or heavier cord.
 - Ensure the color of wires of outdoor unit and the terminal Nos. are the same to the indoor's respectively.
 - Earth lead wire shall be longer than the other lead wires as shown in the figure for the electrical safety in case of the slipping out of the cord from the anchorage.

Terminals on the indoor unit	1(L)	2(N)	
Color of wires			
Terminals on the outdoor unit	1(L)	2(N)	

- Secure the cable onto the control board with the holder (clammer).

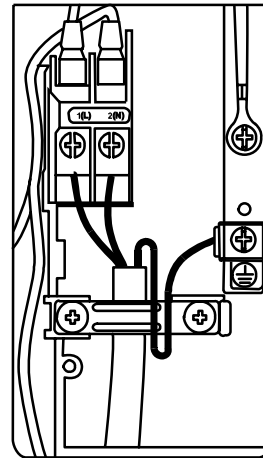

HOW TO TAKE OUT FRONT GRILLE

Please follow the steps below to take out front grille if necessary such as when servicing.

1. Set the vertical airflow direction louver to the horizontal position.
2. Slide down the two caps on the front grille as shown in the illustration at right, and then remove the two mounting screws.
3. Pull the lower section of the front grille towards you to remove the front grille.

When reinstalling the front grille, first set the vertical airflow direction louvre to the horizontal position and then carry out above steps 2 - 3 in the reverse order.

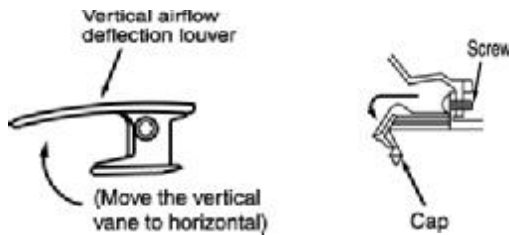

AUTO SWITCH OPERATION

The below operations will be performed by pressing the "AUTO" switch.

1. AUTO OPERATION MODE

The Auto operation will be activated immediately once the Auto Switch is pressed.

2. TEST RUN OPERATION (FOR PUMP DOWN/SERVICING PURPOSE)

The Test Run operation will be activated if the Auto Switch is pressed continuously for more than 5 sec. to below 10 sec. A "pep" sound will occur at the fifth sec., in order to identify the starting of Test Run operation

3. REMOTE CONTROLLER RECEIVING SOUND ON/OFF

The ON/OFF of Remote Controller receiving sound can be changed over by pressing the "AUTO" Switch continuously for 10 sec. and above. A "pep", "pep" sound will occur at the tenth sec., in order to indicate the "ON/OFF" changed over of remote control receiving sound.

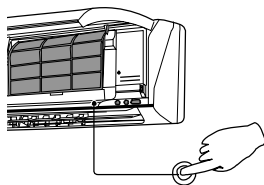

9.3. OUTDOOR UNIT

9.3.1. SELECT THE BEST LOCATION (Refer to "Select the best location" section)

9.3.2. INSTALL THE OUTDOOR UNIT

● After selecting the best location, start installation according to Indoor/Outdoor Unit Installation Diagram.

1. Fix the unit on concrete or rigid frame firmly and horizontally by bolt nut. (ø10 mm).
2. When installing at roof, please consider strong wind and earthquake. Please fasten the installation stand firmly with bolt or nails.

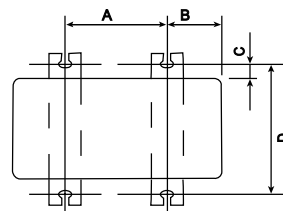

Unit: mm

Model	A	B	C	D
CU-PC9GKV	474	87	19.8	261
CU-PC12GKV	474	87	19.8	261

9.3.3. CONNECTING THE PIPING

Connecting The Piping To Indoor Unit

Please make flare after inserting flare nut (locate at joint portion of tube assembly) onto the copper pipe. (In case of using long piping)

Connect the piping

- Align the center of piping and sufficiently tighten the flare nut with fingers.
- Further tighten the flare nut with torque wrench in specified torque as stated in the table.

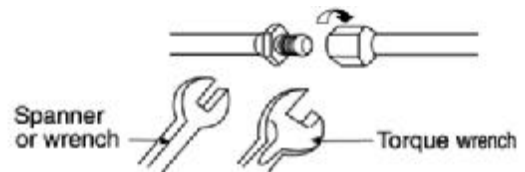

MODEL	Piping size (Torque)	
	Gas	Liquid
CU-PC9GKV	3/8" (42 N.m)	1/4" (18 N.m)
CU-PC12GKV	1/2" (55 N.m)	1/4" (18 N.m)

Connecting The Piping To Outdoor Unit

- Decide piping length and then cut by using pipe cutter. Remove burrs from cut edge. Make flare after inserting the flare nut (located at valve) onto the copper pipe.
- Align center of piping to valves and then tighten with torque wrench to the specified torque as stated in the table.

CUTTING AND FLARING THE PIPING

1. Please cut using pipe cutter and then remove the burrs.
2. Remove the burrs by using reamer. If burrs is not removed, gas leakage may be caused.
Turn the piping end down to avoid the metal powder entering the pipe.
3. Please make flare after inserting the flare nut onto the copper pipes.

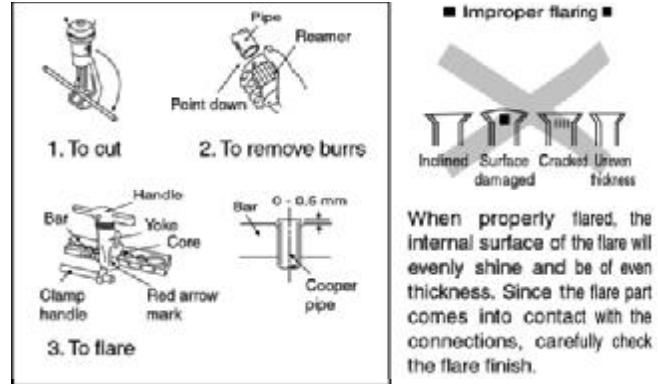

9.3.4. (a) EVACUATION OF THE EQUIPMENT (FOR EUROPE & OCEANIA DESTINATION)

WHEN INSTALLING AN AIR CONDITIONER, BE SURE TO EVACUATE THE AIR INSIDE THE INDOOR UNIT AND PIPES in the following procedure.

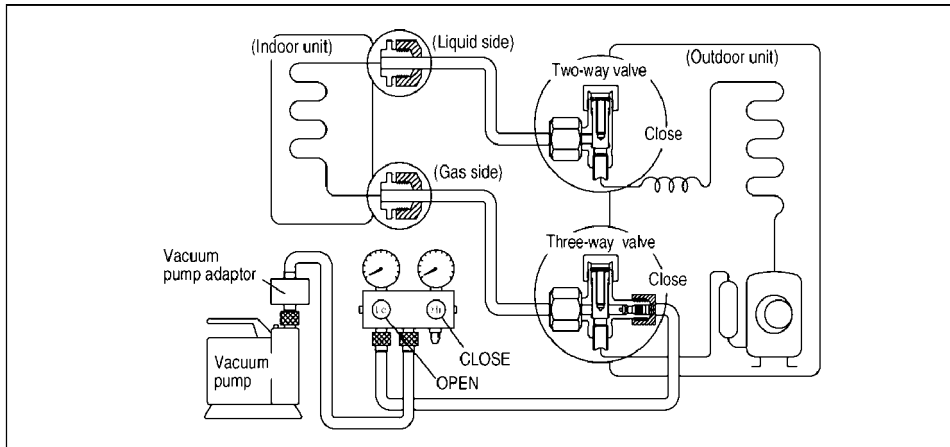

1. Connect a charging hose with a push pin to the Low side of a charging set and the service port of the 3-way valve.
 - Be sure to connect the end of the charging hose with the push pin to the service port.
2. Connect the center hose of the charging set to a vacuum pump with check valve, or vacuum pump and vacuum pump adaptor.
3. Turn on the power switch of the vacuum pump and make sure that the needle in the gauge moves from 0 cmHg (0 MPa) to -76 cmHg (-0.1 MPa). Then evacuate the air approximately ten minutes.
4. Close the Low side valve of the charging set and turn off the vacuum pump. Make sure that the needle in the gauge does not move after approximately five minutes.

Note: BE SURE TO FOLLOW THIS PROCEDURE IN ORDER TO AVOID REFRIGERANT GAS LEAKAGE.
5. Disconnect the charging hose from the vacuum pump and from the service port of the 3-way valve.
6. Tighten the service port caps of the 3-way valve at torque of 18 N.m with a torque wrench.
7. Remove the valve caps of both of the 2-way valve and 3-way valve. Position both of the valves to "OPEN" using a hexagonal wrench (4 mm).
8. Mount valve caps onto the 2-way valve and the 3-way valve.
 - Be sure to check for gas leakage.

CAUTION

- If gauge needle does not move from 0 cmHg (0 MPa) to -76 cmHg (-0.1 MPa), in step 3 above take the following measure:
- If the leak stops when the piping connections are tightened further, continue working from step 3.
- If the leak does not stop when the connections are retightened, repair the location of leak.
- Do not release refrigerant during piping work for installation and reinstallation. Take care of the liquid refrigerant, it may cause frostbite.

9.3.5. (b) AIR PURGING OF THE PIPING AND INDOOR UNIT

The remaining air in the Refrigeration cycle which contains moisture may cause malfunction on the compressor.

1. Remove the caps from the 2-way and 3-way valves.
2. Remove the service-port cap from the 3-way valves.
3. To open the valve, turn the valve stem of 2-way valve counter-clockwise approx. 90° and hold it there for ten seconds, then close it.
4. Check gas-leakage of the connecting portion of the pipings.

For the left pipings, refer to item 4(A).

5. To open 2-way valve again, turn the valve stem counter-clockwise until it stops.

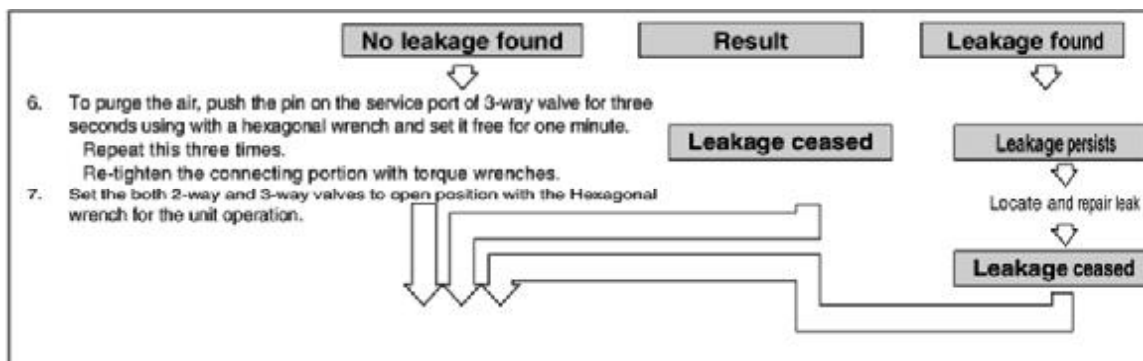
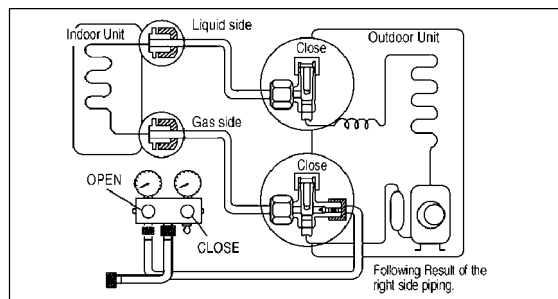
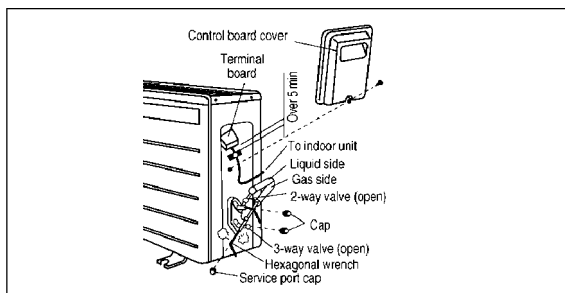

4(A). Checking gas leakage for the left piping.

- (1) * Connect the manifold gauge to the service port of 3-way valve.
* Measure the pressure.

- (2) * Keep it for 5-10 minutes.
Ensure that the pressure indicated on the gauge is the same as that of measured during the first time.

9.3.6. CONNECT THE CABLE TO THE OUTDOOR UNIT

1. Remove the control board cover from the unit by loosening the screw.
2. Connecting cable between indoor unit and outdoor unit shall be approved polychloroprene sheathed 3 x 1.5 mm² flexible cord, type designation 245 IEC 57 or heavier cord.

Terminals on the indoor unit	1(L)	2(N)	
Color of wires			
Terminals on the outdoor unit	1(L)	2(N)	

3. Secure the cable onto the control board with the holder (clammer).
4. Attach the control board cover back to the original position with the screw.

9.3.7. PIPE INSULATION

1. Please carry out insulation at pipe connection portion as mentioned in Indoor/Outdoor Unit Installation Diagram. Please wrap the insulated piping end to prevent water from going inside the piping.
2. If drain hose or connecting piping is in the room (where dew may form), please increase the insulation by using POLY-E FOAM with thickness 6 mm or above.

CHECK THE DRAINAGE

- Open front panel and remove air filters.
(Drainage checking can be carried out without removing the front grille.)
- Pour a glass of water into the drain tray-styrofoam.
- Ensure that water flows out from drain hose of the indoor unit.

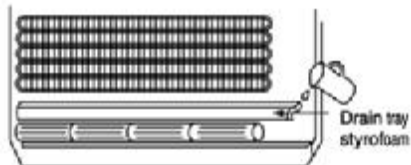

EVALUATION OF THE PERFORMANCE

- Operate the unit for fifteen minutes or more.
- Measure the temperature of the intake and discharge air.
- Ensure the difference between the intake temperature and the discharge is more than 8°C.

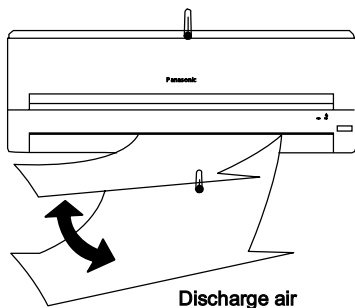

CHECK ITEMS

- Is there any gas leakage at flare nut connections?
- Has the heat insulation been carried out at flare nut connection?
- Is the connecting cable being fixed to terminal board firmly?
- Is the connecting cable being clamped firmly?
- Is the drainage OK?
(Refer to "Check the drainage" section)
- Is the earth wire connection properly done?
- Is the indoor unit properly hooked to the installation plate?
- Is the power supply voltage complied with rated value?
- Is there any abnormal sound?
- Is the cooling operation normal?
- Is the remote control's LCD operation normal?
- Is the air purifying filter installed?

NOTE:

These equipment shall be connected to a suitable mains network with a main impedance less than:
PC9GKV:0.32ohm, PC12GKV: 0.27ohm.

10 2-way,3-way Valve

	2-way Valve (Liquid Side)	3-way Valve (Gas Side)	
Works	Shaft Position	Shaft Position	Service Port
Shipping	Close (With valve cap)	Closed (With valve cap)	Closed (With cap)
Air purging(Installation and Re-installation)	Open (Counter-clockwise)	Closed (clockwise)	Open (Push-pin)
Operation	Open (Counter-clockwise)	Open (With valve cap)	Closed (With cap)
Pumping down (Transferring)	Closed (Clockwise)	Open (Counter-clockwise)	Open (Connected manifold gauge)
Evacuation (Servicing)	Open	Open	Open (With vacuum pump)
Charging (Servicing)	Open	Open	Open (With charging cylinder)
Pressure check (Servicing)	Open	Open	Open (Connected manifold gauge)
Gas releasing (Servicing)	Open	Open	Open (Connected manifold gauge)

10.1. Evacuation of Installation

When installing an air conditioner, be sure to evacuate the air inside the indoor unit and pipes in the following procedure.

Required tools:

Hexagonal wrench, adjustable wrench, torque wrench, wrench to hold the joints, gas leak detector, charging set and vacuum pump.

The air in the indoor unit and in the piping must be purged. If air remains in the refrigeration piping, it will affect the compressor, reduce cooling capacity, and could lead to a malfunction.

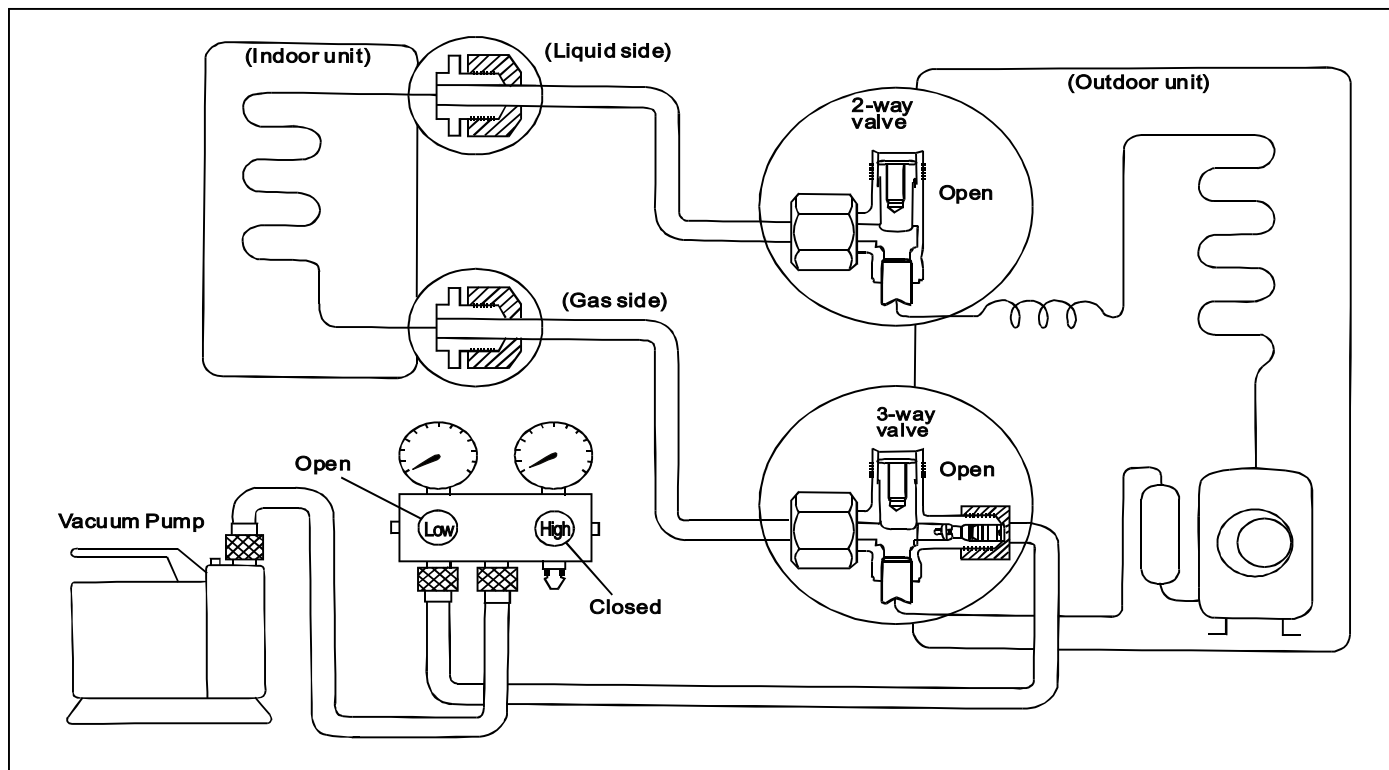

Service port cap

Be sure, using a torque wrench to tighten the service port cap(after using the service port),so that it prevents the gas leakage from the refrigeration cycle.

Procedure:

- 1.Connect a charging hose with a push pin to the Low side of a charging set and the service port of the 3-way valve.

Be sure to connect the end of the charging hose with the push pin to the service port.

- 2.Connect the centre hose of the charging set to a vacuum pump.
- 3.Turn on the power switch of the vacuum pump and make sure that the needle in the gauge moves from 0 cmHg (0 Mpa) to -76 cmHg (-0.1 Mpa). Then evacuate the air for approximately 10 minutes.
- 4.Close the valve of the Low side of the charging set and turn off the vacuum pump. Make sure that the needle in the gauge does not move after approximately 5 minutes.
BE SURE TO TAKE THIS PROCEDURE IN ORDER TO AVOID GAS REFRIGERANT LEAKAGE.
- 5.Disconnect the charging hose from the vacuum pump and from the service port of the 3-way valve.

- 6.Tighten the service port caps of both the 3-way valve and the 2-way valve at a torque of 18 N.m with a torque wrench.

- 7.Remove the valve caps of both the 3-way and the 2-way valves.

Position both of the valves to "open" using a hexagonal wrench (4 mm).

- 8.Mount valve caps onto both of the 3-way valve and the 2-way valve.

Be sure to check for gas leakage.

Caution

If gauge needle does not move from 0 cmHg(0 Mpa) to -76cmHg (-0.1MPa) in step (3) above, take the following measures:
If the leaks stop when the piping connections are tightened further, continue working from step (3).
If the leaks do not stop when the connections are retightened, repair the location of the leak.

10.2. Pumping down

(For Re-Installation)

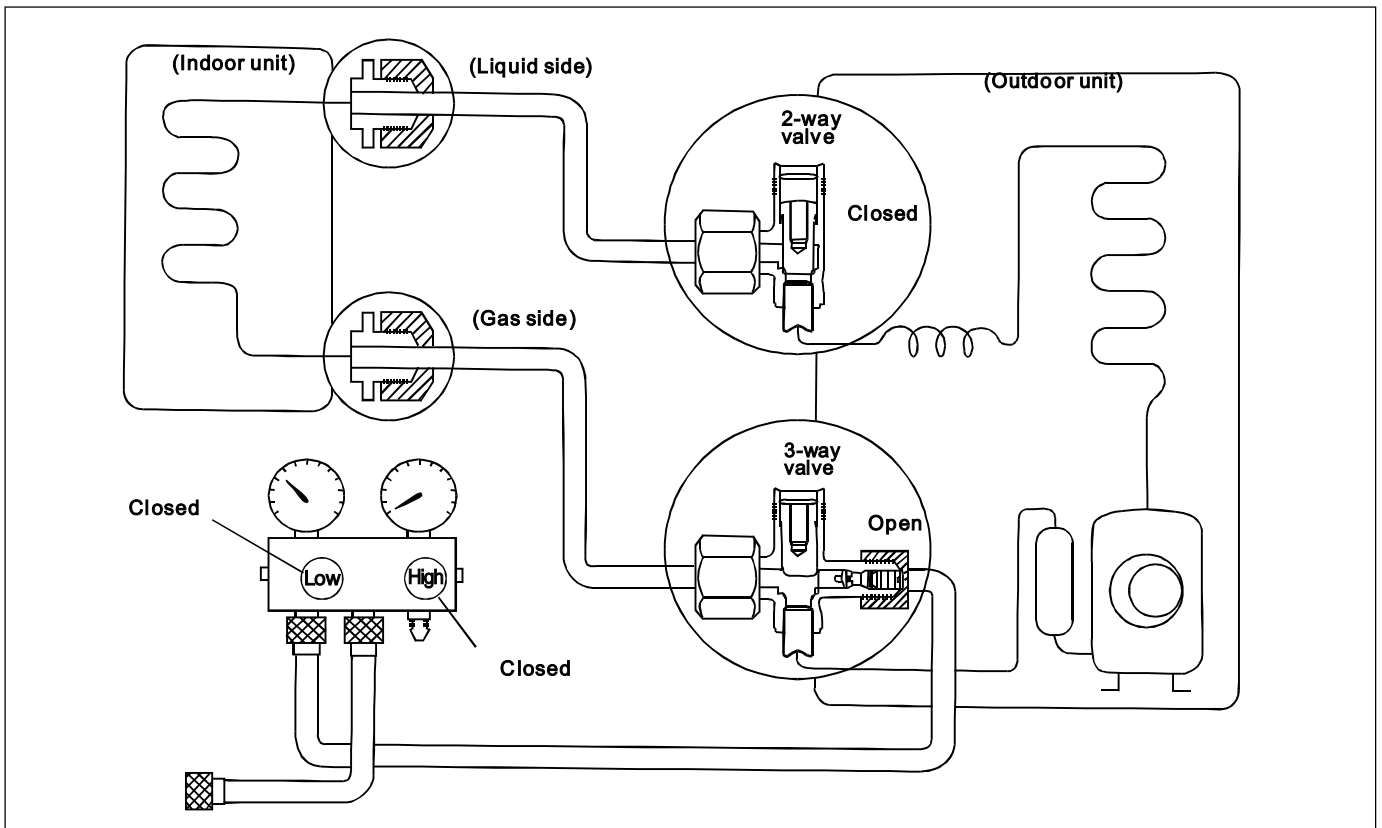

Procedure

1. Confirm that both 2-way and 3-way valves are set to open positions.
 - Remove the valve stem cap and confirm that the valve stems are in the open position.
 - Be sure using a hexagonal wrench to operate the valve stems.
2. Operate the unit for 10-15 minutes.
3. Stop operation and wait for 3 minutes, then connect the charge set to the service port of the 3-way valve.
 - Connect the charge hose with the push pin to the service port.
4. Air purging of the charge hose.
 - Open the low-pressure valve of the charge set slightly to purge air from the charge hose.
5. Set the 2-way valve to the close position.
6. Operate the air conditioner at the cooling cycle and stop it when the gauge indicates 2 kg/cm²G (0.1Mpa).
 - If the unit cannot be operated at the cooling mode operation (weather is rather cold), short the Pumping Down pins on the Main Control P.C.B.
7. Immediately set 3-way valve to the closed position.
 - Do this quickly so that the gauge ends up indicating 1 to 3kg/cm²G (0.1 to 0.3 Mpa).
8. Use refrigerant reclaiming equipment to collect refrigerant from indoor unit and pipes.
9. Disconnect the charge set, and mount the 2-way and 3-way valve stem's nuts and service port cap.
 - Use torque wrench to tighten the service port cap to a torque 1.8kgf.m (18N.m).
 - Be sure to check for gas leakage.
10. Disconnect pipes from indoor unit and outdoor unit.

10.3.Re-air Purging

(Re-installation)

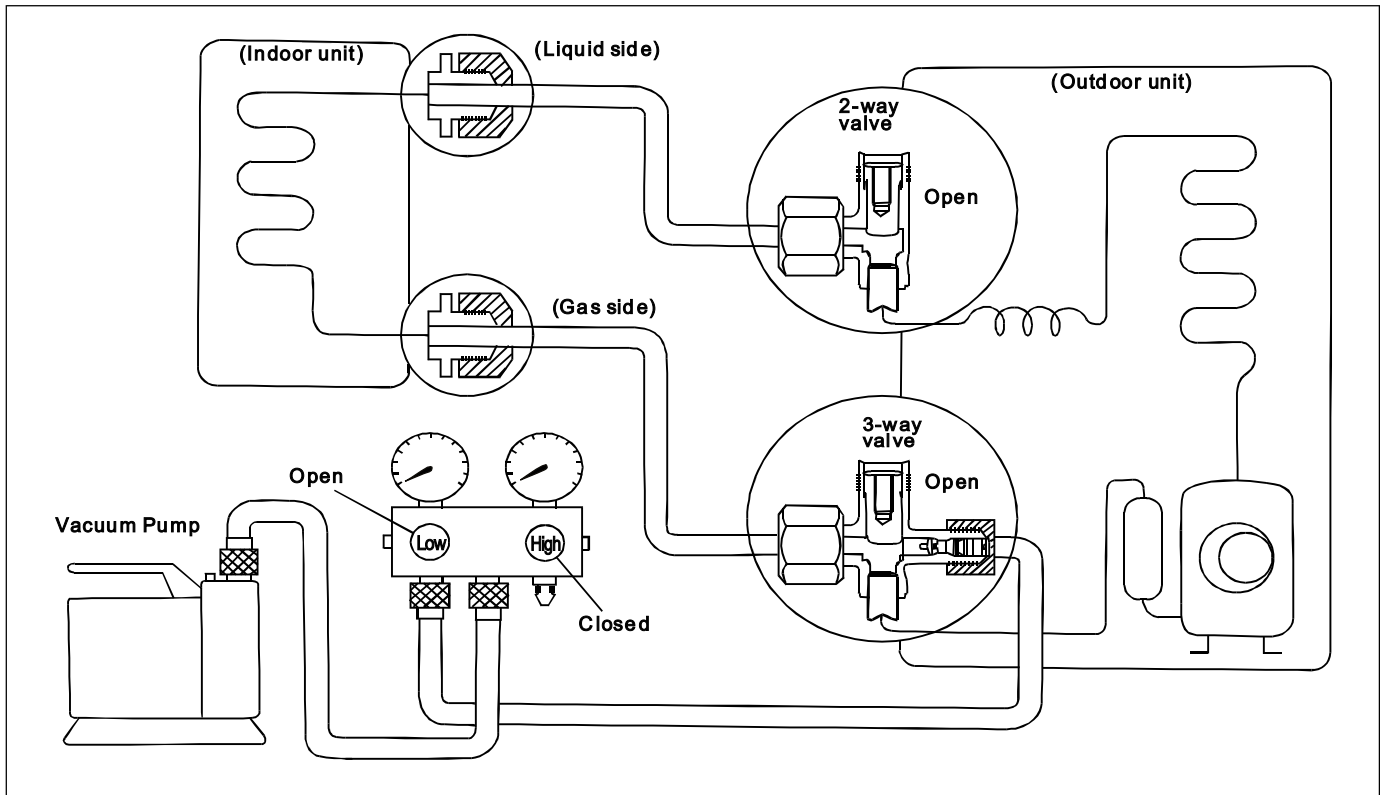

1. Connect a charging hose with a push pin to the Low side of a charging set and the service port of a 3-way valves.

Be sure to connect the end of the charging hose with the push pin to the service port.

2. Connect the centre hose of the charging set to a vacuum pump.
3. Turn on the power switch of the vacuum pump and make sure that the needle in the gauge moves from 0 cmHg (0 Mpa) to -76 cmHg (-0.1 Mpa). Then evacuate the air for approximately 10 minutes.
4. Close the valve of the Low side of the charging set and turn off the vacuum pump. Make sure that the needle in the gauge does not move after approximately 5 minutes.

BE SURE TO TAKE THIS PROCEDURE IN ORDER TO AVOID GAS REFRIGERANT LEAKAGE.

5. Disconnect the charging hose from the vacuum pump
6. Charge the pipes and indoor unit with gas refrigerant from 3-way valve service port, and then discharge the refrigerant until low side (gas side) gauge needle indicates 0.3 Mpa (3 kg/cm²).

7. Tighten the service port caps of both the 3-way valve and the 2-way valve at a torque of 18 N.m with a torque wrench.

8. Remove the valve caps of both the valves. Position both of the valves to "open" using a hexagonal wrench (4 mm).

9. Mount valve caps onto both the valves.

- BE SURE TO USE REFRIGERANT RECLAIMING EQUIPMENT WHILE DISCHARGING THE REFRIGERANT.
- Purge the air from charge set's centre hose.
- Be sure to check for gas leakage.

Caution

If gauge needle does not move from 0 cmHg(0 Mpa) to -76cmHg (-0.1MPa) in step (3) above, take the following measures:
If the leaks stop when the piping connections are tightened further, continue working from step (3).
If the leaks do not stop when the connections are retightened, repair the location of the leak.

10.4. Balance refrigerant of the 2-way,3-way valves

(Gas leakage)

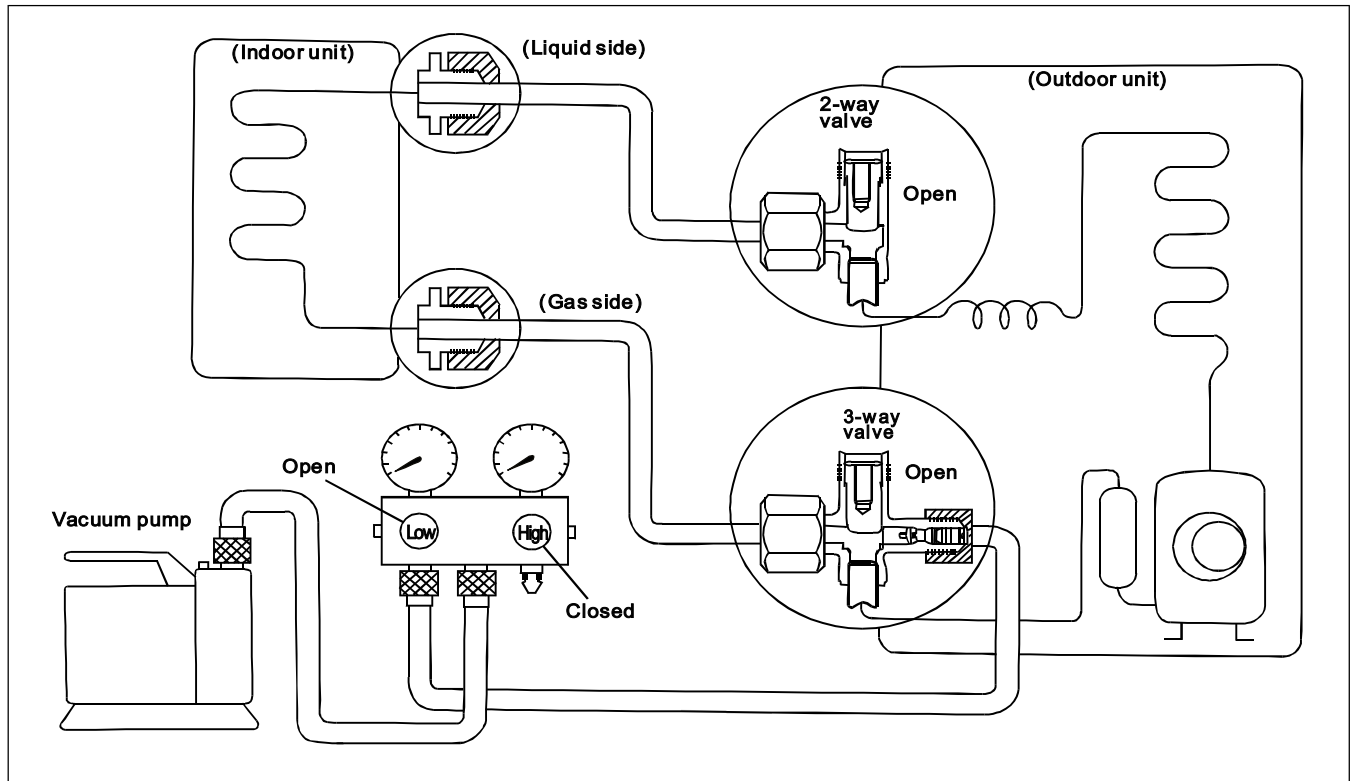

Procedure

1. Confirm that both the 3-way valve and 2-way valve are set to the open position.
2. Connect the charge set to the 3-way valve's service port.
 - Leave the valve on the charge set closed.
 - Connect the charge hose with the push-pin to the service port.
 - Confirm whether the pressure indicates more than 1 kg/cm²G (0.1MPa).
3. Connect the charge set's centre hose to refrigerant reclaiming equipment.
4. Open the valve (Low side) on the charge set and discharge the refrigerant until the gauge indicates 0.05 MPa (0.5 kg/cm²G) to 0.1 MPa (1 kg/cm²G).
 - If there is no air in the refrigeration cycle (the pressure when the air conditioner is not running is higher than 0.1 MPa (1 kg/cm²G), discharge the refrigerant until the gauge indicates 0.05 MPa (0.5 km/cm²G) to 0.1 MPa (1 kg/cm²G). If this is the case, it will not be necessary to apply a evacuation.
 - Discharge the refrigerant gradually; if it is discharged too suddenly, the refrigeration oil will also be discharged.
5. Turn on refrigerant reclaiming equipment to collect the refrigerant until the needle indicates 0 (no refrigerant is remaining).

10.5. Evacuation (Installation)

(No refrigerant in the refrigeration cycle)

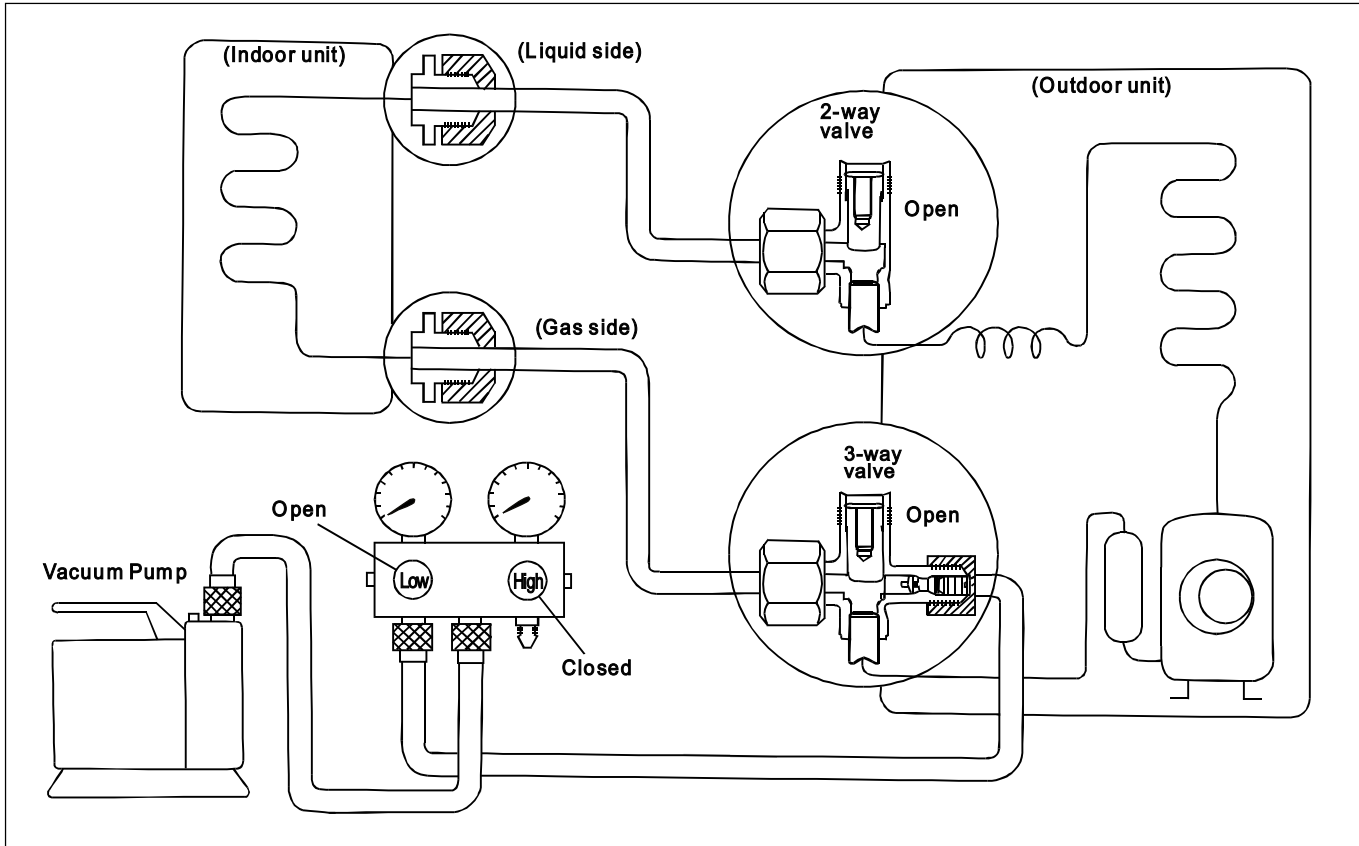

Procedure

1. Connect the vacuum pump to the charge set's centre hose.

2. Evacuation for approximately 1 hour.

- Confirm that the gauge needle has moved toward -76cmHg (-0.1MPa) [vacuum of 4 mmHg or less].

3. Close the valve (Low side) on the charge set, turn off the vacuum pump, and confirm that the gauge needle does not move (approximately 5 minutes after turning off the vacuum pump).

4. Disconnect the charge hose from the vacuum.

- Vacuum oil
If the vacuum pump oil becomes dirty or depleted, replenish as needed.

10.6. Gas charging

(After Evacuation)

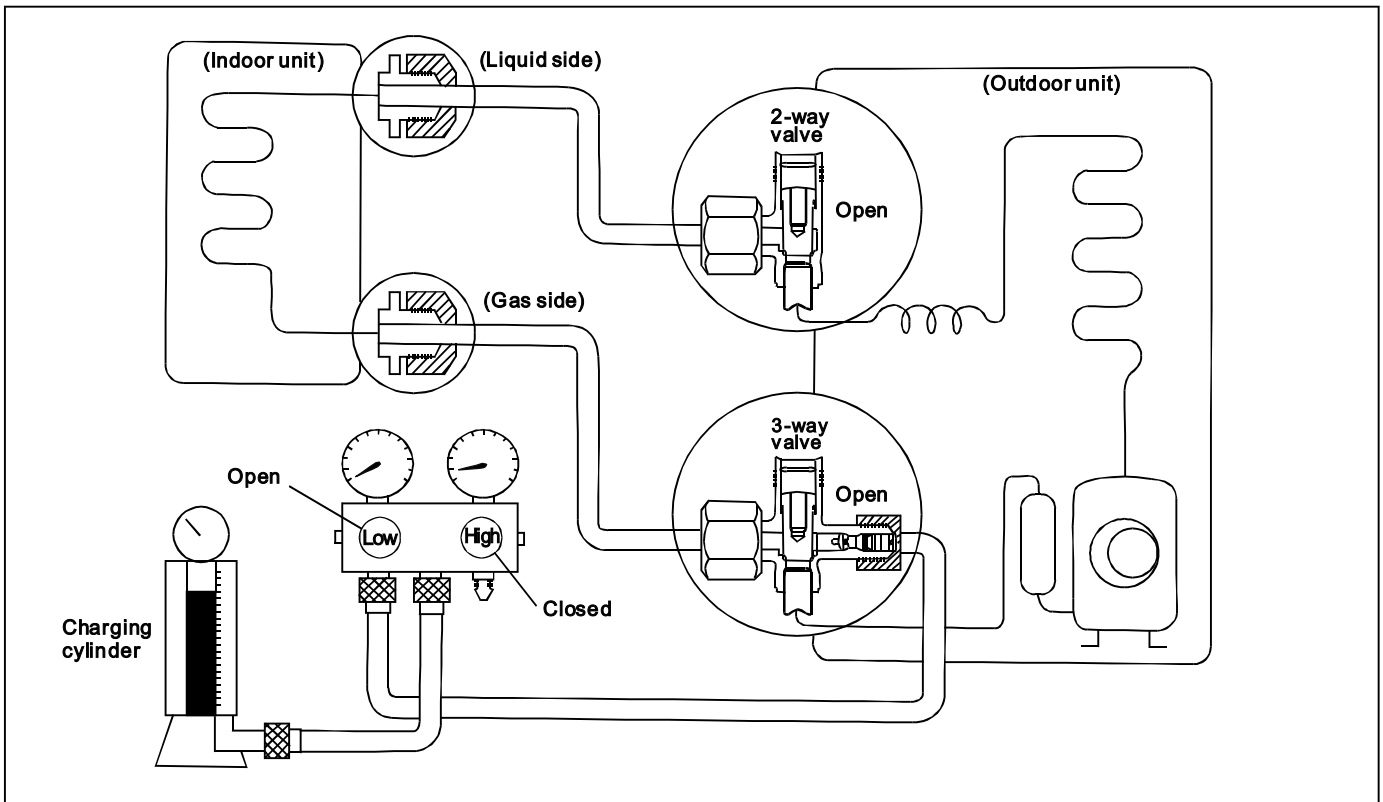

Procedure

1. Connect the charge hose to the charging cylinder.

- Connect the charge hose which was disconnected from the vacuum pump to the valve at the bottom of the cylinder.
- If you are using a gas cylinder also use a scale and reverse the cylinder so that the system can be charged with liquid.

2. Purge the air from the charge hose.

- Open the valve at the bottom of the cylinder and use a screwdriver to press the check valve on the charge set to purge the air. (Be careful of the liquid refrigerant.)
- The procedure is the same if using a gas cylinder.

3. Open the valve (Low side) on the charge set and charge the system with liquid refrigerant.

- If the system cannot be charged with the specified amount of refrigerant, it can be charge with a little at a time (approximately 150g each time) while operating the air conditioner in the cooling cycle. However, one time is not sufficient, wait approximately 1 minute and then repeat the procedure. (Pumping down pin)

This is different from previous procedures. Because you are charging with liquid refrigerant from the gas side, absolutely do no attempt to charge with large amount of liquid refrigerant while operating the air conditioner.

4. Immediately disconnect the charge hose from the 3-way valve's service port.

- Stopping part-way will allow the refrigerant to be discharged.
- If the system has been charged with liquid refrigerant while operating the air conditioner, turn off the air conditioner before disconnecting the hose.

5. Mount the valve stem nuts and the service port.

- Use a torque wrench to tighten the service port cap to a torque of 1.8kgf.m (18 N.m)
- Be sure to check for gas leakage.

11 Disassembly of the parts

Removal Procedure For Intake Grille

1. Open the intake grille and pull it to the horizontal position. (Fig. 1)



Fig. 1

2. Pull up the intake grille until it falls off. (Fig. 2)



Fig. 2

Removal Procedure For Front Grille

1. Remove the two caps at the discharge port (right and left) (Fig. 3)

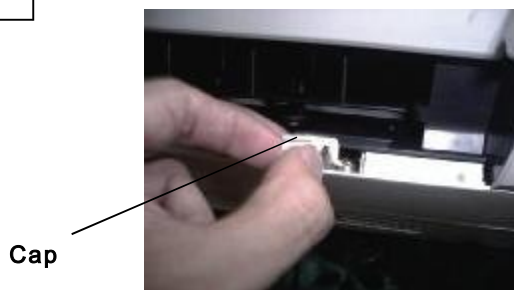

Fig. 3

2. Release the two screws under the both caps. (Fig. 4)



Fig. 4

3. Pull out the front grille from the unit body. (Fig.5)

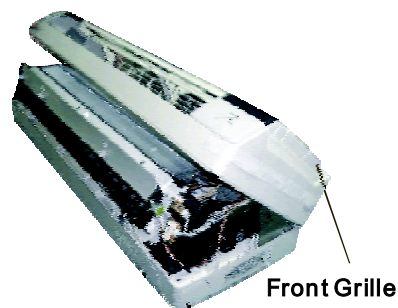

Fig. 5

Removal Procedure For Electronic Controller

1. Release tabs of the control box cover and detach the control box cover .
Release the fixing screws of the control box. (Fig. 6)

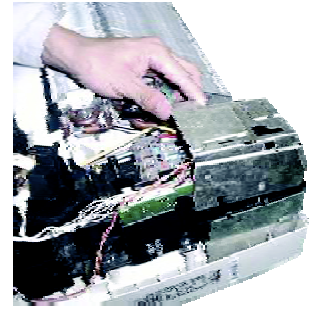

Fig 6

2. Release the lead wire CN-FM, CN-FB, CN-AIR, CN-STM,CN-RCV ,
CN-DISP and earth wire(Yellow/Green). Pull out the whole electronic
controller.



Fig 7

Removal Procedure For the Discharge Grille

1. Separate the drain hose and the drain plate(Fig. 8)



Fig 8

2. Pull out the discharge grille slightly (Fig. 9)

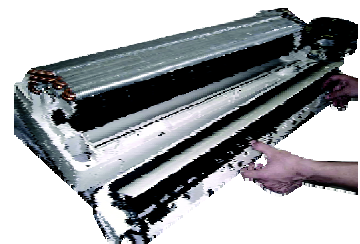

Fig. 9

Removal Procedure For Cross Flow Fan

1. Release the two fixing screws on the left side of the evaporator and lift up the evaporator slightly. (Fig. 10)

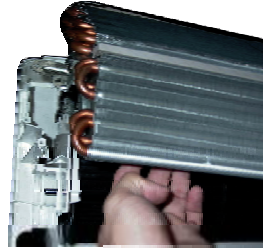
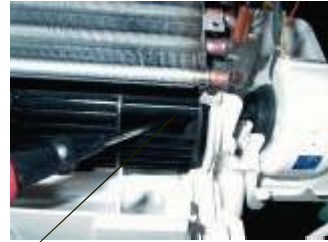

Fig. 10

2. Loose the fixing screw of the cross flow fan. (Fig. 11)



Fixing Screw

Fig. 11

3. After removing the bearing (refer to fig.12), indoor fan can be taken out from the left side.

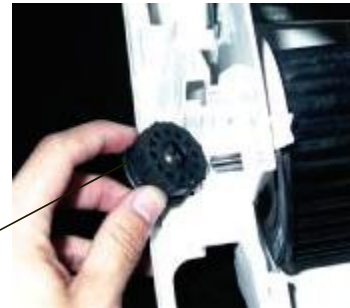

Bearing

Fig 12

4. Lift up the indoor fan slightly, and then pull the fan motor out. (Fig13)

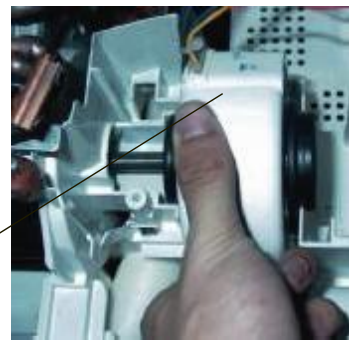

Fan motor

Fig 13

Remote control reset

If the display is chaotic or can not be adjusted, Remove the back lid of the remote control and you will find the resetting terminals and shorten the two terminals using a screw driver to reset.

Resetting terminals

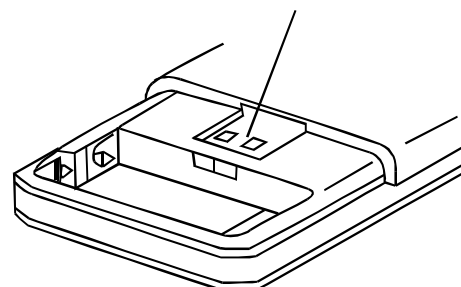

Fig 14

12 Troubleshooting Guide

12.1. Refrigeration cycle system

In order to diagnose malfunctions, make sure that there are no electrical problems before inspecting the refrigeration cycle. Such problems include insufficient insulation, problem with the power source, malfunction of compressor or fan. The normal outlet air temperature and pressure of the refrigeration cycle depends on various conditions, the standard values for them are shown in the table to the right.

Normal pressure and outlet air temperature(standard)

	Gas side pressure Mpa (kg/cm ² G)	Outlet air temperature (°C)
Cooling mode	0.4~0.6(4~6)	12~16

★ Condition: indoor fan speed: high
outdoor temperature:
35°C (Cooling mode)

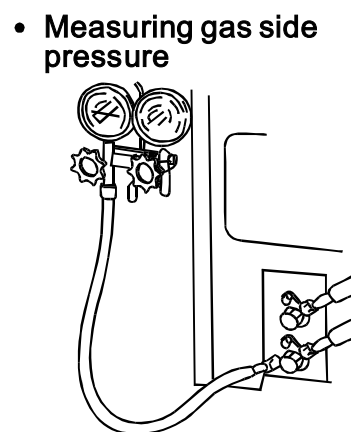
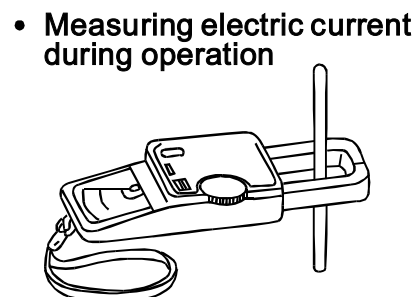
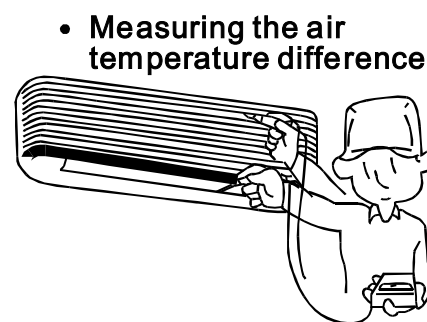
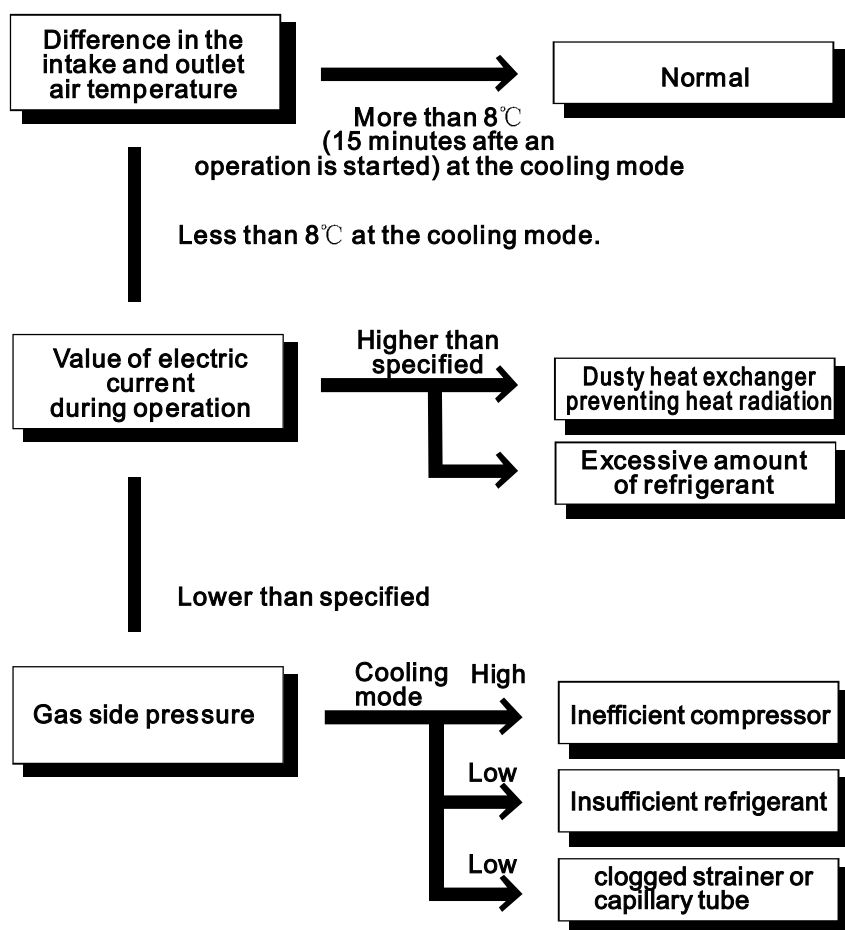

12.2. Relationship between the condition of air conditioner and pressure and electric current

Condition of the air conditioner	Cooling mode		
	Low pressure	High pressure	Electric current during operation
Insufficient refrigerant (gas leakage)	↓	↓	↓
Clogged capillary tube	↓	↓	↓
Short circuit in the indoor unit	↓	↓	↓
Heat radiation deficiency of the outdoor unit	↗	↗	↗
Insufficient compression	↗	↓	↓

12.3. Diagnosis methods of a malfunction of a compressor .

Nature of fault	Symptom
Insufficient compressing of a compressor	<ul style="list-style-type: none"> • Electric current during operation becomes approximately 80% lower than the normal level. • The discharge tube of the compressor becomes abnormally hot (normally 70~90°C). • The difference between high pressure and low pressure becomes almost zero.
Locked compressor	<ul style="list-style-type: none"> • Electric current reaches a high level abnormally, and the value exceeds the limit of an ammeter. In some cases, a breaker turns off. • The compressor has a humming sound.

13 Technical Data

■ Thermostat characteristics

• Cooling mode

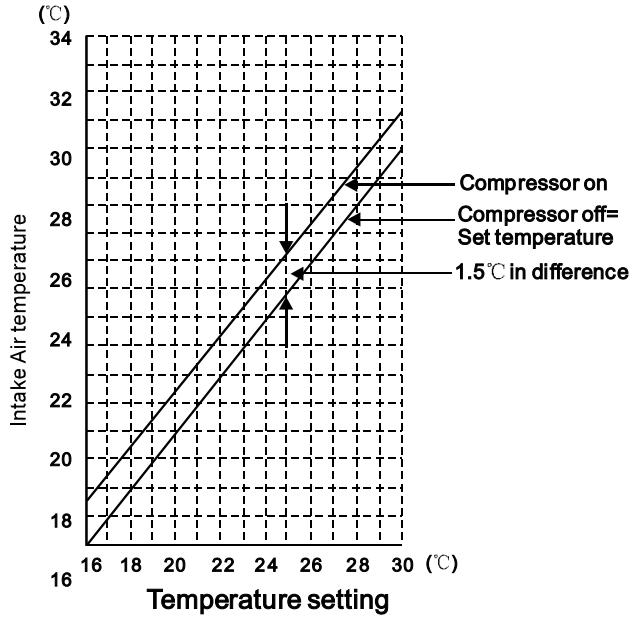

• Soft dry mode

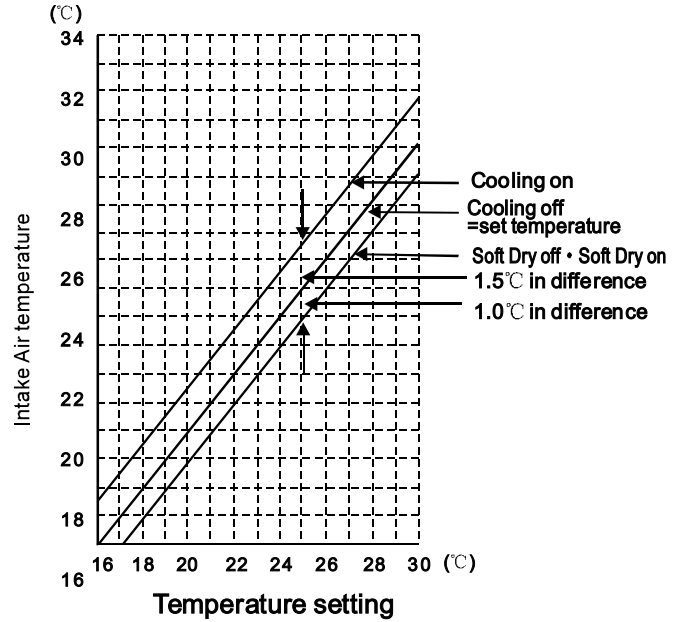

■ Cooling characteristics

• CS/CU-PC9GKV

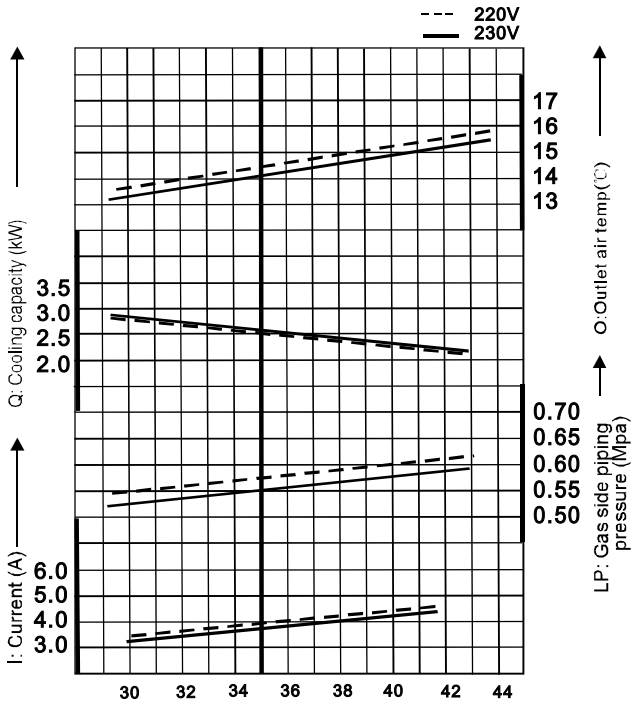

Outdoor temp (°C)
[Condition] Room temp: 27/19°C
Cooling operation: at high speed
Piping length: 5m

• CS/CU-PC12GKV

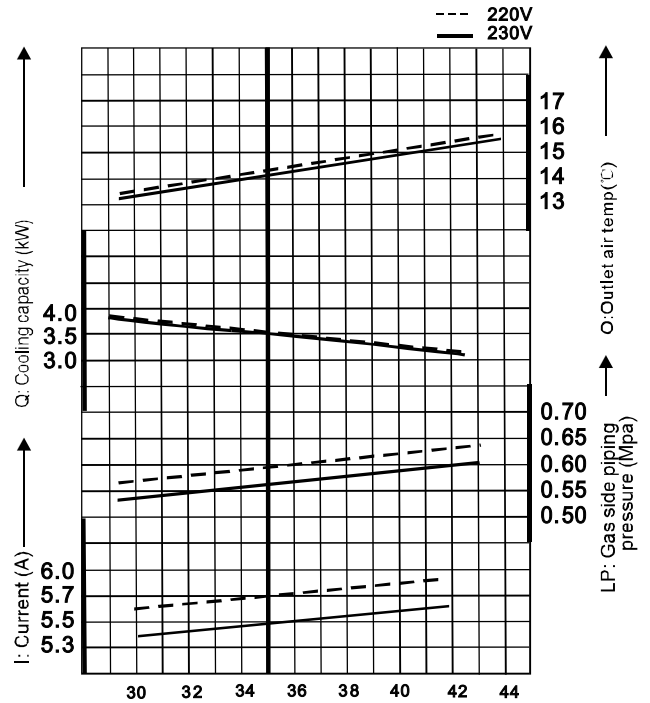

Outdoor temp (°C)
[Condition] Room temp: 27/19°C
Cooling operation: at high speed
Piping length: 5m

14 Exploded View

CS-PC9GKV
CS-PC12GKV

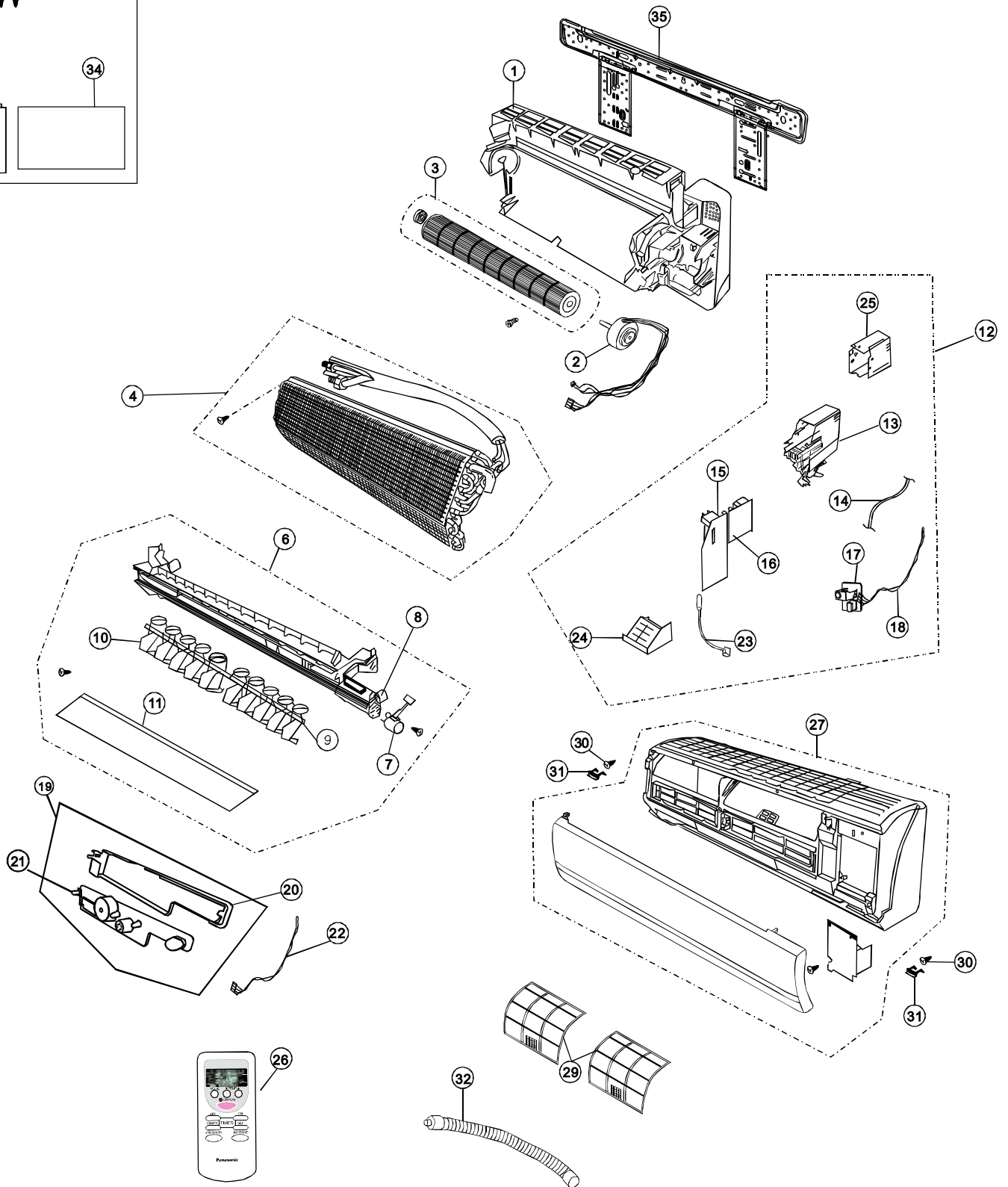
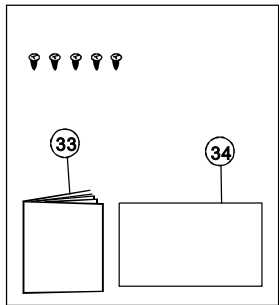

15 Replacement Parts List

CS-PC9GKV/CS-PC12GKV

No.	PART NAME & DESCRIPTION	Q'TY	CS-PC9GKV	CS-PC12GKV	RE
1	CHASSIS COMPLETE	1	CWD50C1531	CWD50C1531	
2	FAN MOTOR	1	CWA921310	CWA921310	*
3	CROSS FLOW FAN COMPLETE	1	CWH02C1051	CWH02C1051	
4	EVAPORATOR	1	CWB30C2146	CWB30C2147	
6	DISCHARGE GRILLE COMPLETE	1	CWE20C2691	CWE20C2700	
7	AIR SWING MOTOR	1	CWA981184	CWA981184	
8	DAIN ELBOW	1	CWH52160C	CWH52160C	
9	HORIZONTAL VANE(RIGHT)	2	CWE24C1184	CWE24C1184	
10	HORIZONTAL VANE(LEFT)	1	CWE24C1184	CWE24C1184	
11	VERTICAL VANE	1	CWE241141	CWE241141	
12	C-BOX	1	CWH14C5725	CWH14C5702	*
13	CONTROL BOARD	1	CWH102261	CWH102261	
14	POWER SUPPLY CORD COMPLETE	1	CWA20C2602	CWA20C2602	
16	MAIN PCB	1	CWA73C2639	CWA73C2619	*
17	RECEIVER	1	CWA743353	CWA743353	
19	INDICATOR COMPLETE	1	CWE39C1134	CWE39C1134	
20	INDICATOR HOLDER-FRONT	1	CWD932447	CWD932447	
21	INDICATOR PCB	1	CWA743929	CWA743929	
22	CONNECTING LEAD-INDICATOR	1	CWA67C5169	CWA67C5169	
23	SENSOR COMPLETE	1	CWA50C2275	CWA50C2275	*
24	CONTROL BOARD FRONT COVER	1	CWH131189	CWH131189	
25	CONTROL BOARD TOP COVER	1	CWH131256	CWH131256	
26	REMOTE CONTROL	1	CWA75C2710	CWA75C2710	*
27	FRONT GRILLE COMPLETE	1	CWE11C3744	CWE11C3744	
29	AIR FILTER	2	CWD001110	CWD001110	
30	SCREW-FRONT GRILLE	2	XTT4+14CFJ	XTT4+14CFJ	
31	CAP-FRONT GRILLE	2	CWH521096	CWH521096	
32	DRAIN HOSE	1	CWH851095	CWH851095	
33	OPERATING INSTRUCTIONS	1	CWF565591	CWF565591	
34	INSTALLATION INSTRUCTION	1	CWF613190	CWF613190	
35	INSTALLATION PLATE	1	CWH36K1025	CWH36K1025	

Note:

- 1.All parts are supplied from PHAAG, P.R. China.
- 2.** marked parts are recommended to be kept in stock.

16 Exploded View

CU-PC9GKV
CU-PC12GKV

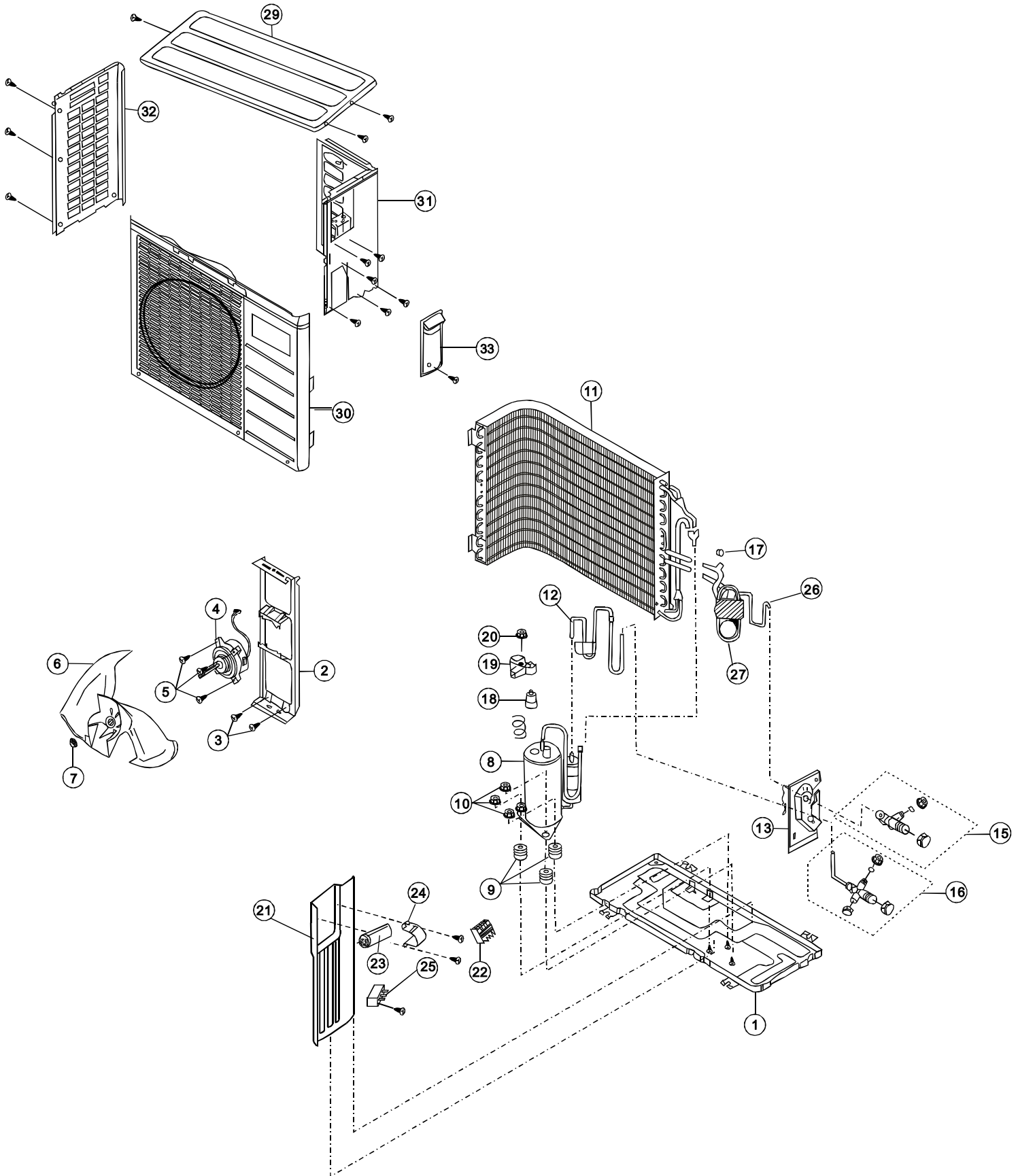

17 Replacement Parts List

CU-PC9GKV/CU-PC12GKV

No.	PART NAME & DESCRIPTION	Q'TY	CU-PC9GKV	CU-PC12GKV	RE
1	CHASSIS ASS'Y	1	CWD52K1174A	CWD52K1174A	
2	FAN MOTOR BRACKET	1	CWD541094	CWD541097	
3	SCREW-FAN MOTOR BRACKET	2	XTT4+10DFJ	XTT4+10DFJ	
4	FAN MOTOR	1	CWA951374	CWCWA951374	*
5	SCREW-FAN MOTOR MOUNT	3	CWH55252J	CWCWH55252J	
6	PROPELLER FAN ASS'Y	1	CWH03K1025	CWCWH03K1025	
7	NUT-PROPELLER FAN	1	CWH561036J	CWCWH561036J	
8	COMPRESSOR	1	CWB092308	CWCWB092309	*
9	ANTI-VIBRATION BUSHING	3	CWH501022	CWCWH501022	
10	NUT-COMPRESSOR MOUNT	3	CWH561047A	CWCWH561047A	
11	CONDENSER	1	CWB32C2023	CWB32C1785	
12	TUBE ASSY(3 WAY-VALVE)	1	CWT024727	CWCWT024728	
13	HOLDER COUPLING ASS'Y	1	CWH351064A	CWCWH351064A	
15	2-WAY VALVE	1	CWB021260	CWB021359	
16	3-WAY VALVE	1	CWB011322	CWB011476	
17	STRAINER	1	CWB111026	CWB111026	
18	OVER LOAD PROTECTOR	1	CWA121212	CWA121172J	
19	TERMINAL COVER	1	CWH17006	CWH17006	
20	NUT FOR TERMIANL COVER	1	7080300J	7080300J	
21	SOUND PROOF BOARD	1	CWH151080	CWCWH151080	
22	TERMINAL BOARD ASS'Y	1	CWA28K1105	CWCWA28K1105	
23	CAPACITOR-COMPRESSOR	1	DS371306CPXC	CWDS371306CPXC	*
24	HOLDER-CAPACITOR	1	CWH301037	CWCWH301037	
25	CAPACITOR-FAN MOTOR	1	F0DAH2050001	CWF0DAH2050001	*
26	TUBE ASS'Y(CAPILLARY TUBE)	1	CWT01C4198	CWT01C4182	
27	CAPILLARY		CWB15340	CWB15450	
29	TOP PLATE	1	CWE031044A	CWCWE031044A	
30	CABINET FRONT PLATE	1	CWE06K1049	CWCWE06K1049	
31	CABINET SIDE PLATE (R)	1	CWE041125A	CWCWE041125A	
32	CABINET SIDE PLATE (L)	1	CWE041124A	CWCWE041124A	
33	CONTROL BOARD COVER	1	CWH131223	CWH131223	

Note:

- 1.All parts are supplied from PHAAG, P.R. China.
- 2."*" marked parts are recommended to be kept in stock.