



# SPLIT-TYPE AIR CONDITIONER

INDOOR UNIT    OUTDOOR UNIT

<b>Basic Model</b>	<b>AQV09UGEN</b>	<b>AQV09EWEX</b>
	<b>AQV12UGEN</b>	<b>AQV12EWEX</b>
	<b>AQV18UGDNEUR</b>	<b>AQV18UGDXEUR</b>
	<b>AQV24UGDNEUR</b>	<b>AQV24UGDEUR</b>
	<b>AQV30UWCNXXSA</b>	<b>AQV36JAXKCV</b>
<b>Model Code</b>	<b>AQN09VFUAGM/CV</b>	<b>AQX09VFUAGM/CV</b>
	<b>AQN12VFUAGM/CV</b>	<b>AQX12VFUAGM/CV</b>
	<b>AQN18VFUAGM/CV</b>	<b>AQX18VFUAGM/CV</b>
	<b>AQN24VFUAGM/CV</b>	<b>AQX24VFUAGM/CV</b>
	<b>AQN36VFUAGM/CV</b>	<b>AQX36VFUAGM/CV</b>

# SERVICE Manual

## AIR CONDITIONER



**AQN09VFUAGM/CV**  
**AQN12VFUAGM/CV**



**AQN18VFUAGM/CV**  
**AQN24VFUAGM/CV**



**AQN36VFUAGM/CV**



**AQX09VFUAGM/CV**  
**AQX12VFUAGM/CV**  
**AQX18VFUAGM/CV**



**AQX24VFUAGM/CV**



**AQX36VFUAGM/CV**

## THE FEATURE OF PRODUCT

High Energy Efficiency BLDC

Air Conditioner

good'sleep Mode

good'sleep Mode can help you sleep quickly and soundly and wake up refreshed.

Silence Mode

When you use the "Silence Mode", you can experience extremely quiet operation of your air conditioner.

Refer to the service manual in the GSPN(see the rear cover) for the more information.

# Contents

<b>1. Precautions</b> .....	<b>1-1</b>
1-1 Installing the air conditioner .....	1-1
1-2 Power supply and circuit breaker .....	1-1
1-3 During operation .....	1-1
1-4 Disposing of the unit .....	1-2
1-5 Others .....	1-2
<b>2. Product Specifications</b> .....	<b>2-1</b>
2-1 The Feature of Product .....	2-1
2-2 Product Specifications .....	2-2
2-3 The Comparative Specifications of Product .....	2-3
2-4 Accessory and Option Specifications .....	2-4
<b>3. Alignment and Adjustments</b> .....	<b>3-1</b>
3-1 Test Mode .....	3-1
3-2 Display Error and Check Method .....	3-2
3-3 Setting Option Setup Method .....	3-4
<b>4. Disassembly and Reassembly</b> .....	<b>4-1</b>
4-1 Indoor Unit .....	4-2
4-2 Outdoor Unit .....	4-8
<b>5. Exploded Views and Parts List</b> .....	<b>5-1</b>
5-1 Indoor Unit .....	5-1
5-2 Outdoor Unit .....	5-3
5-3 Ass'y Control In .....	5-5
5-4 Ass'y Control Out .....	5-7
<b>6. Indoor Wiring Diagram</b> .....	<b>6-1</b>
<b>7. Outdoor Wiring Diagram</b> .....	<b>7-1</b>
<b>8. Schematic Diagram</b> .....	<b>8-1</b>
8-1 Indoor Unit .....	8-1
8-2 Outdoor Unit .....	8-2

# Contents

<b>9. Refrigerating Cycle Diagram</b> .....	<b>9-1</b>
<b>10. PCB Diagram</b> .....	<b>10-1</b>
10-1 Indoor PCB .....	10-1
10-2 Outdoor PCB .....	10-2
<b>11. Operating Instructions</b> .....	<b>11-1</b>
11-1 Name of Each Part .....	11-1
11-2 Wireless Remote Control-Buttons and Display .....	11-3
11-3 Main Function .....	11-4
<b>12. Troubleshooting</b> .....	<b>12-1</b>
12-1 Items to be checked first .....	12-1
12-2 Fault Diagnosis by Symptom .....	12-2
12-3 PCB Inspection Method .....	12-25
12-4 Main Part Inspection Method .....	12-27
<b>13. Block Diagram</b> .....	<b>13-1</b>
13-1 Indoor Unit .....	13-1
13-2 Outdoor Unit .....	13-3
<b>14. Reference Sheet</b> .....	<b>14-1</b>
14-1 Index for Model Name .....	14-1
14-2 Low Refrigerant Pressure Distribution .....	14-2
14-3 Pressure & Capacity mark .....	14-3
14-4 Q & A for Non-trouble .....	14-4
14-5 Cleaning/Filter Change .....	14-7
14-6 Installation .....	14-9
14-7 Installation Diagram of Indoor Unit and Outdoor Unit .....	14-10
<b>15. WORKING RANGE</b> .....	<b>15-1</b>
15-1 Power Supply .....	15-1
15-2 Working Range.....	15-1

---

# 1. Precautions

---

## 1-1 Installing the air conditioner

---

- Users should not install the air conditioner by themselves.  
Ask the dealer or authorized company to install the air conditioner except the window-type air conditioner in U.S.A and Canada.
- If you don't install the air conditioner properly, it may cause a fire, a water leakage or an electric shock.
- You must install the air conditioner according to the national wiring regulations and safety regulations.
- Install the indoor unit higher than 2.5m from the floor to avoid the injury caused by the operation of the fan.  
(except the window-type air conditioner)
- The manufacturer is not responsible for any accidents or injury caused by an incorrect installation.
- When installing the built-in type air conditioner, keep all electric cables such as the power cable and the connection cord in pipes, ducts, or cable channels to protect them from the danger of impact or any other incidents.

## 1-2 Power supply and circuit breaker

---

- If the power cord of the air conditioner is damaged, it must be replaced by the manufacturer or a qualified person in order to avoid a hazard.
- The air conditioner must be plugged into an independent circuit if applicable or connect the power cable to the auxiliary circuit breaker.  
An all pole disconnection from the power supply must be incorporated in the fixed wiring with a contact opening of >3mm.
- Do not extend an electric cord to the air conditioner.
- The air conditioner must be plugged in after you complete the installation.

## 1-3 During operation

---

- Do not repair the air conditioner at your discretion.  
It is recommended to contact a service center directly.
- Never spill any kind of liquid on the air conditioner.  
If this happens, turn off the air conditioner and contact an authorized service center.
- Do not insert anything between the airflow blades to prevent damage of the inner fan and consequent injury.  
Keep children away from the air conditioner.
- Do not place any obstacles in front of the air conditioner.
- Do not spray any kind of liquid into the indoor unit. If this happens, turn off the air conditioner and contact a service center.
- Make sure that the air conditioner is well ventilated at all times:  
 Do not place a cloth or other materials over it.
- Remove the batteries if you don't use the remote control for a long time. (If applicable)
- Use the remote control within 7 meters from the indoor unit. (If applicable)

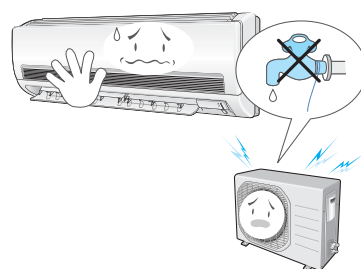

## 1-4 Disposing of the unit

---

- Before throwing out the air conditioner, remove the batteries from the remote control.
- When you dispose of the air conditioner, consult your dealer. If pipes are removed incorrectly, refrigerant may blow out and cause air pollution. When it contacts with your skin, it can cause skin injury.
- The package of the air conditioner should be recycled or disposed of properly for environmental reasons.

## 1-5 Others

---

- Never store or load the air conditioner upside down or sideways to prevent the damage to the compressor.
- Young children or infirm persons should be always supervised when they use the air conditioner.
- Max current is measured according to IEC standard for safety.
- Current is measured according to ISO standard for energy efficiency.

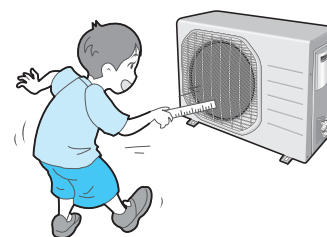

---

## 2. Product Specifications

---

### 2-1 The Feature of Product

---

- **good'sleep Mode**

good' sleep mode can help you sleep quickly and soundly and wake up refreshed.

- **Catech in Filter**

- **Silver Nano Evap orator**

- **Deo dorizing Filter**

then withclean,refreshin air

## 2-2 Product Specifications

Item				Model		AQ09VFUAGM/CV		AQ12VFUAGM/CV	
						Indoor Unit	Outdoor Unit	Indoor Unit	Outdoor Unit
Type				Wall-mounted		Wall-mounted			
Performance	Capacity	Cooling	kW (Low / Std / Max)	0.821/2.638/3.312		0.821/3.517/3.986			
		Heating		0.791/3.517/4.396		0.791/3.986/5.129			
	Running Frequency	Cooling	Hz (Low / Std / Max)	20 / 48 / 63		20 / 71 / 82			
		Heating		20 / 71 / 85		20 / 83 / 100			
	Dehumidifying		ℓ/h	-		-			
	Air Volume	Cooling	m <sup>3</sup> /min (H/M/L)	-	-	-	-		
		Heating		-	-	-	-		
	Noise	Cooling	dB (H/L)	43	51	43	53		
		Heating		43	51	43	53		
	Energy Efficiency Ratio	Cooling	W/W (Std)	3.94/13.43/14.17		3.26/11.11/11.72			
Heating		3.66/12.50/13.19		3.41/11.62/12.26					
Power		ph-V-Hz	1-208/230-60		1-208/230-60				
Power	Power Consumption	Cooling	W (Low / Std / Max)	200/670/900		210/1080/1250			
		Heating		190/960/1250		190/1170/1550			
	Operating Current	Cooling	A (Low / Std / Max)	1.5/3.8/4.5		1.5/5.5/5.8			
		Heating		1.3/5.0/6.0		1.3/6.1/7.0			
	Power Factor	Cooling	%	75 / 90 / 95		75 / 90 / 95			
		Heating		75 / 90 / 95		75 / 90 / 95			
Size	Outer Dimension		W x H x D	mm	880*360*260	926*640*384	880*360/260	926*640*384	
	Weight(Net)			kg	8.2	30.5	8.2	30.5	
	Refrigerant Pipe	Liquid	mm x L(m)	Φ 6.35 x 7.5		Φ 6.35 x 7.5			
		Gas	mm x L(m)	Φ 9.52 x 7.5		Φ 9.52 x 7.5			
	Drain Hose		D x L(mm)	Φ20*550		Φ20*550			
	Compressor	Type		Rotary UG9A090FUBJPSS		Rotary ,UG9A090FUBJPSS			
		Motor	Type	Hermetic		Hermetic			
			Rated Output	875		875			
	Oil Type			FREOLa68ES-T		FREOLa68ES-T			
	Blower	Type		Cross-flow	Propeller	Cross-flow	Propeller		
Motor		Type	Resin /Steel	Resin /Steel	Resin /Steel	Resin /Steel			
		Rated Output	W	40	93	40	93		
Heat Exchanger				2 Row 14 Step	1 Row 24 Step	2 Row 14 Step	1 Row 24 Step		
Refrigerant Control Unit				EEV		EEV			
Freezer Oil Capacity		cc	700		700				
Refrigerant to Change (R410A)		g	900		900				
Protection Device(OLP)				None		None			
Cooling TestCondition				Indoor Unit : DB80°F WB67°F (Indoor Unit : DB 27°C WB19°C)		Outdoor Unit : DB95°F WB75°F (Outdoor Unit : DB35°C WB24°C)			
Heating TestCondition				Outdoor Unit : DB68°F WB59°F (Outdoor Unit : DB 20°C WB15°C)		Outdoor Unit : DB47°F WB43°F (Outdoor Unit : DB 7°C WB6°C)			
Operation conditon range	cooling	indoor	61°F~90°F(16°C~32°C)		61°F~90°F(16°C~32°C)				
		Outdoor	14°F~114.8°F(-10°C~46°C)		14°F~114.8°F(-10°C~46°C)				
	heating	indoor	80°F( 27°C ) or less		80°F( 27°C ) or less				
		Outdoor	5°F~75°F(-15°C~24°C)		5°F~75°F(-15°C~24°C)				

## 2-2 Product Specifications



Item				Model		AQ18VFUAGM/CV		AQ24VFUAGM/CV	
						Indoor Unit	Outdoor Unit	Indoor Unit	Outdoor Unit
Type				Wall-mounted		Wall-mounted			
Performance	Capacity	Cooling	kW (Low / Std / Max)	1.29/5.27/6.15		1.29/7.03/7.91			
		Heating		0.82/6.00/7.47		1.67/7.91/9.96			
	Running Frequency	Cooling	Hz (Low / Std / Max)	15 / 72 / 82		15 / 76 / 88			
		Heating		15 / 76 / 93		15 / 76 / 100			
	Dehumidifying		ℓ/h	-		-			
	Air Volume	Cooling	m <sup>3</sup> /min (H/M/L)	-	-	-	-		
		Heating		-	-	-	-		
	Noise	Cooling	dB (H/L)	48	58	48	58		
		Heating		48	58	48	58		
	Energy Efficiency Ratio	Cooling	W/W (Std)	2.9/9.89/10.42		2.82/9.64/10.17			
Heating		3.37/12.52/12.13		2.99/10.19/10.75					
Power		ph-V-Hz	1-208/230-60		1-208/230-60				
Power	Power Consumption	Cooling	W (Low / Std / Max)	300/1820/2000		370/2490/2800			
		Heating		240/1780/2300		350/2650/3500			
	Operating Current	Cooling	A (Low / Std / Max)	2.2/8.9/9.5		2.6/11.9/12.5			
		Heating		2.0/8.8/10.5		2.3/13.3/16.5			
Power Factor	Cooling	%	75 / 90 / 95		75 / 90 / 95				
	Heating		75 / 90 / 95		75 / 90 / 95				
Size	Outer Dimension		W x H x D	mm	1125*375*290	926*640*384	1125*375*290	1023*413*925	
	Weight (Net)			kg	11.5	38.5	11.5	53.5	
	Refrigerant Pipe	Liquid	mm x L(m)	Φ 6.35 x 7.5		Φ 6.35 x 7.5			
		Gas	mm x L(m)	Φ 12.7 x 7.5		Φ 15.88 x 7.5			
	Drain Hose		D x L(mm)	Φ20*550		Φ20*550			
	Compressor	Type		Rotary,UG4T150FUDJQ		Rotary,UG4T200FUA4			
		Motor	Type	Hermetic		Hermetic			
	Rated Output		1369		1788				
	Oil Type		FREOLa68ES-T		FREOLa68ES-T				
	Blower	Type		Cross-flow	Propeller	Cross-flow	Propeller		
Motor		Type	Resin/Steel	Resin/Steel	Resin/Steel	Resin/Steel			
	Rated Output		40	93	40	93			
Heat Exchanger				2Row16(15)Step	2Row 24 Step	2Row16(15) Step	2 Row 36 Step		
Refrigerant Control Unit				EEV		EEV			
Freezer QI Capacity			cc	700		700			
Refrigerant to Change (R410A)			g	1300		1650			
Protection Device(OLP)				None		None			
Cooling TestCondition				Indoor Unit : DB80°F WB67°F (Indoor Unit : DB 27°C WB19°C)		Outdoor Unit : DB95°F WB75°F (Outdoor Unit : DB35°C WB24°C)			
Heating TestCondition				Outdoor Unit : DB68°F WB59°F (Outdoor Unit : DB 20°C WB15°C)		Outdoor Unit : DB47°F WB43°F (Outdoor Unit : DB 7°C WB6°C)			
Operation conditon range	cooling	indoor	61°F~90°F(16°C~32°C)		61°F~90°F(16°C~32°C)				
		Outdoor	14°F~114.8°F(-10°C~46°C)		14°F~114.8°F(-10°C~46°C)				
	heating	indoor	80°F(27°C) or less		80°F(27°C) or less				
		Outdoor	5°F~75°F(-15°C~24°C)		5°F~75°F(-15°C~24°C)				



## 2-2 Product Specifications

Item				Model		AQ36VFUAGM/CV	
						Indoor Unit	Outdoor Unit
Type				Wall-mounted			
Performance	Capacity	Cooling	kW (Low / Std / Max)	2.64/9.67/11.14			
		Heating		2.64/9.96/13.19			
	Running Frequency	Cooling	Hz (Low / Std / Max)	15/53/70			
		Heating		15/51/67			
	Dehumidifying		ℓ/h	-			
	Air Volume	Cooling	m <sup>3</sup> /min (H/M/L)	-	-		
		Heating		-	-		
	Noise	Cooling	dB (H/L)	56	66		
		Heating		56	66		
	Energy Efficiency Ratio	Cooling	W/W (std)	11.00			
Heating		10.63					
Power		ph-V-Hz	1-208/230-60				
Power	Power Consumption	Cooling	W (Low / Std / Max)	680/3000/4000			
		Heating		620/3200/4500			
	Operating Current	Cooling	A (Low / Std / Max)	3.6/14.2/18.0			
		Heating		3.3/15.0/21.0			
	Power Factor	Cooling	% (Low / Std / Max)	80/90/95			
		Heating		80/90/95			
Size	Outer Dimension		W x H x D	mm	1352*420*326      1095*476*1285		
	Weight (Net)			kg	18.2      87.0		
	Refrigerant Pipe	Liquid	mm x L(m)		Φ6.35 x 7.5		
		Gas	mm x L(m)		Φ12.7 x 7.5		
	Drain Hose			D x L(mm)	Φ20 x 550		
	Compressor	Type		Rotary,G5T360FUCEK			
		Motor	Type		Hermetic		
			Rated Output		3409W		
	Oil Type			POE			
	Blower	Type		Cross-flow	Propeller		
Motor		Type		Resin / Steel	Resin / Steel		
		Rated Output	W	40	93		
Heat Exchanger				2 Row	18 • Step      2 Row 52 Step		
Refrigerant Control Unit				EEV			
Freezer Oil Capacity			cc	500			
Refrigerant to Change (R410A)			g	2500			
Protection Device (OLP)				None			
Cooling Test Condition				DB27°C WB 19°C	DB35°C WB 24°C		
Heating Test Condition				DB20°C WB 15°C	DB7°C WB 6°C		
Operation conditon range	cooling	indoor		16°C ~ 32°C			
		Outdoor		-10°C ~ 46°C			
	heating	indoor		27°C or less			
		Outdoor		-15°C ~ 24°C			

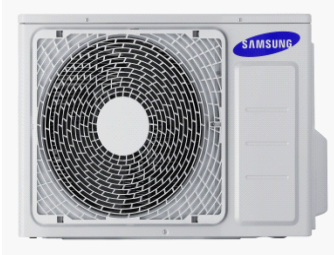
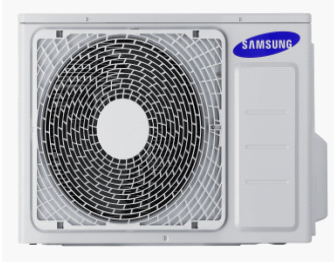

## 2-3 The Comparative Specifications of Product

Item		Development Model	Development Model
		AQ09VFUAGM/CV	AQ12VFUAGM/CV
Design	Indoor Unit		
	Outdoor Unit		
Net Weight	Indoor Unit	8.2Kg	8.2Kg
	Outdoor Unit	30.5Kg	30.5Kg
Outer Dimension (WidthxHeightxDepth)	Indoor Unit	880*360*260	880*360*260
	Outdoor Unit	926*640*384	926*640*384
Noise	Indoor Unit	43dB	43dB
	Outdoor Unit	51dB	53dB
Air Purifying System	Filter	Evaporator Catechin Filter	Evaporator Catechin Filter
Indoor Display		Three Color LED Display	Three Color LED Display

## 2-3 The Comparative Speciation of Product





Item		Development Model	
		AQ18VFUAGM/CV	AQ24VFUAGM/CV
Design	Indoor Unit		
	Outdoor Unit		
Net Weight	Indoor Unit	11.5Kg	11.5Kg
	Outdoor Unit	38.5Kg	53.5Kg
Outer Dimension (WidthxHeightxDPTH)	Indoor Unit	1125*375*290	1125*375*290
	Outdoor Unit	926*640*384	1023*413*925
Noise	Indoor Unit	48dB	48dB
	Outdoor Unit	58dB	58dB
Air Purify System	Filter	Evaporator Catechin Filter	Evaporator Catechin Filter
Indoor Display		Three Cd or LED Display	Three Cd or LED Display

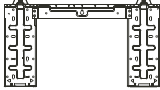

## 2-3 The Comparative Specifications of Product

Item		Development Model
		AQ36VFUAGM/CV
Design	Indoor Unit	
	Outdoor Unit	
Net Weight	Indoor Unit	18.2kg
	Outdoor Unit	87.0kg
Outer Dimension (WidthxHeightxDepth)	Indoor Unit	1352*420*326 (mm <sup>3</sup> )
	Outdoor Unit	1095*476*1285 (mm <sup>3</sup> )
Noise	Indoor Unit	56dB ↓
	Outdoor Unit	66dB ↓
Air Purifying System	Filter	Evaporator Catechin Filter
Indoor Display		Three Color LED Display

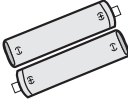
## 2-4 Accessory and Option Specifications

### 2-4-1 Accessories

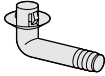
Item	Descriptions	Code-No.	Q'TY	Remark
	Assy Plate-Hanger	DB97-02851C [AQN09VFUAGM/CV] [AQN12VFUAGM/CV] DB90-02738A [AQN18VFUAGM/CV] [AQN24VFUAGM/CV] DB70-00787A [AQV36VFUAGM/CV]	1	Indoor Unit
	Remote Control	DB93-11115Y [AQN09VFUAGM/CV] [AQN12VFUAGM/CV] [AQN18VFUAGM/CV] [AQN24VFUAGM/CV] [AQN36VFUAGM/CV]	1	
	Batteries for Remote Control	DB47-90024A [AQN09VFUAGM/CV] [AQN12VFUAGM/CV] [AQN18VFUAGM/CV] [AQN24VFUAGM/CV] [AQN36VFUAGM/CV]	2	
	Manual	DB98-32163A [AQN09VFUAGM/CV] [AQN12VFUAGM/CV] [AQN18VFUAGM/CV] [AQN24VFUAGM/CV] [AQN36VFUAGM/CV]	1	

Item	Descriptions	Code-No.	Q'TY	Remark
	Drain Plug	DB67-20011A [AQX09VFUAGM/CV] [AQX12VFUAGM/CV] [AQX18VFUAGM/CV] [AQX24VFUAGM/CV] DB67-00477A [AQX36VFUAGM/CV]	1	Outdoor Unit
	Rubber Leg	DB73-20134A [AQX09VFUAGM/CV] [AQX12VFUAGM/CV] [AQX18VFUAGM/CV] [AQX24VFUAGM/CV]	4	

## 3. Alignment and Adjustments

### 3-1 Test Mode

#### ■ How to Approach Test Mode

You can approach the Test Mode by pressing the on/off switch of indoor unit for 5 seconds.

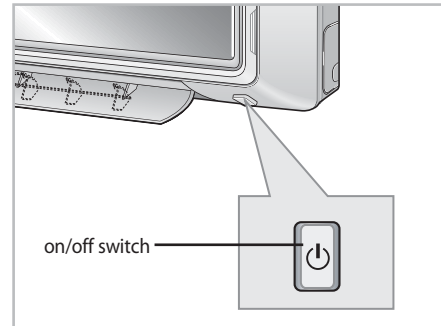

#### ■ Test Mode Operation Option

After installing the air conditioner, check whether each subordinate is normally operated or not by operating the Test Mode.

- **When an error occurs, display the Error Mode.**
- **Operation Mode :** Cool mode. Operate the cool mode by operating the compressor by force without the compressor ON/OFF according to the set temperature/indoor temperature. (Do not follow the antifreeze control)
- **Up-down louver :** Up-down swing mode
- **Indoor Fan :** High



• Because the Test Mode operate the cool mode by force not related to the set temperature / indoor temperature, check whether each subordinate is operated normally or not after completing installation and must turn off the power of the air conditioner.

## 3-2 Display Error and Check Method

### 3-2-1 Indoor Display Error and Check Method

ERROR MODE			DESCRIPTION
Oper.	Timer	Good Sleep	
×	○	○	Communication error (indoor<->outdoor) Pre power relay error
×	○	×	Indoor room temp sensor error
○	○	×	Evap in temp sensor error
×	×	○	Fan error(indoor)
○	×	○	Outdoor error display
○	○	○	EEPROM error
○	○	○	Option error

- LED ON
  - LED BLINKING
  - ×
- LED OFF



### 3-2-2 Outdoor LED Display Error and Check Method

AQX09/12/18/24VFUAGM/CV

LED PATTERN			DESCRIPTION
YEL	GRN	RED	
○	○	○	Power Off / VDD NG
○	◎	●	Normal Operation
○	○	◎	IPM Over Current(O.C)
○	○	●	Abnormal Serial communication (Display Board:Indoor<->Outdoor)
○	◎	○	Comp Starting error
○	●	◎	DC-Link voltage under/over error PFC over load / HW DC_link over
◎	○	◎	Outdoor temp sensor error(Dual/Single)
◎	○	●	Discharge over temperature(Dual/Single)
◎	◎	○	Discharge temp sensor error(Dual/Single)
◎	◎	●	Current sensor error/Heatsink sensor error Input current sensor error
◎	●	○	Comp Vlimit error/Heatsink over temp
◎	●	◎	Coil temp sensor error(Dual/Single)
◎	●	●	1min. Time out Comm. (Main <-> Inverter)
●	○	○	Fan error
○	●	○	EEProm data error
●	○	◎	OTP error
●	○	●	Comp rotation error
●	◎	○	Operation condition secession(Dual only)
●	◎	◎	DC-Link voltage sensor error
●	◎	●	I-Trip error / PFC Over current
●	●	○	GAS Leak error(Dual/Single)
●	●	◎	AC Line Zero Cross Signal out
●	●	●	Power ON reset(1sec)
◎	○	○	capacity miss match
○	◎	◎	Test Operation Cooling Mode
◎	◎	◎	Test Operation Heating Mode

● LED ON ○ LED OFF ◎ LED BLINKING

### 3-2-2 Outdoor LED Display Error and Check Method

AQX36VFUAGM/CV

LED DISPLAY			7 SEGMENT DISPLAY	DISCRIPTION
R	G	Y		
●	○	○	—	NORMAL OPERATION
●	○	○	E201	Unit Quantity Miss Matching between Indoor and Outdoor
●	●	○	E202	Abnormal state or 1min Time out Comm between Indoor and Outdoor
●	○	○		
●	●	○	E203	1min Time out Comm between Inverter and Outdoor
●	○	○	E221	Outdoor Temp Sensor error
●	○	○	E231	Cond Temp Sensor error
●	○	○	E251	Discharge Temp Sensor error
●	○	○	E320	OLP Sensor error
●	○	○	E403	Detection of Outdoor Freezing when Comp Stop
●	○	○	E404	Protection of Outdoor Overload when Comp Stop
●	○	○	E416	Discharge over Temp error when Comp Stop
●	○	○	E440	Out of Operation Temp range in Heating
●	○	○	E441	Out of Operation Temp range in Cooling
○	○	●	E458	Outdoor Fan1 error
○	○	○	E461	Comp Starting error
●	○	○	E462	I_Trip error/PFC Over Current
●	○	○	E463	OLP Over Heat and Comp Stop
○	○	○	E464	IPM Over Current(O.C) error
○	●	○	E465	COMP Over Load error
○	●	○	E466	DC Link Under/Over Voltage error
●	○	●	E467	COMP Wire Missing error
●	○	○	E468	Current Sensor error
○	○	●	E469	DC Link Voltage Sensor error
●	○	○	E471	Outdoor EEPROM error
○	○	○	E474	Heatsink Sensor error
○	○	●	E475	Outdoor Fan2 error
●	○	●	E484	PFC Over Load error
○	○	○	E500	Heatsink Over Heat error
●	○	○	E554	GAS Leak error
●	○	○	E556	Capacity Miss Matching between Indoor and Outdoor
●	○	○	E557	Option Code Miss Matching among the Indoors(only for DPM)

● : ON    ○ (with dot) : BLINKING    ○ : OFF

### 3-3 Setting Option Setup Method

ex) Option No. :

SEG1	SEG2	SEG3	SEG4	SEG5	SEG6	SEG7	SEG8	SEG9	SEG10	SEG11	SEG12	SEG13	SEG14	SEG15	SEG16	SEG17	SEG18
0	1	2	3	0	5	1	7	4	2	7	B	2	7	4	4	4	E
SEG19	SEG20	SEG21	SEG22	SEG23	SEG24	SEG25	SEG26	SEG27	SEG28	SEG29	SEG30	SEG31	SEG32	SEG33	SEG34	SEG35	SEG36
3	7	8	2	0	0	0	3	4	C	4	B	1	0	4	4	4	2

**NOTE :**

SEG1, SEG7, SEG13, SEG19 need not to be pressed in, so in fact the Option No. we should press in is as below.

12305 7427d 7444E 78200 34C4b 04442

**Step 1 : Enter the Option Setup mode.**







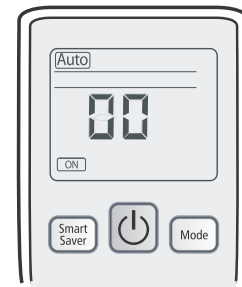



















1<sup>st</sup> Take out the batteries of remote control.

2<sup>nd</sup> Press the temperature  button simultaneously and insert the battery again.















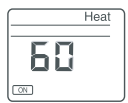













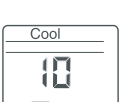

3<sup>rd</sup> Make sure the remote contr display shown as  .



**Step 2 : Enter the Option Setup mode and select your option according to the following procedure.**

	Feature	Display
	<p><b>1</b> The default value is  .</p> <p>Every time you push the  button, the display panel reads  Auto → Cool → Dry → Fan → Heat ,  Auto → Cool → Dry → Fan → Heat repeatedly.</p>	
	<p><b>2</b> Push the  button to set the display panel to 3 .</p> <p>Every time you push the  button, the display panel reads 0 → 1 → 2 → 3 → ..... → 9 → A → b → c → d → E → F repeatedly.</p>	
	<p><b>3</b> Push the  button to  .</p> <p>Every time you push the  button, the display panel reads 0 → 1 → 2 → 3 → ..... → 9 → A → b → c → d → E → F repeatedly.</p>	
	<p><b>4</b> Push the  button to  .</p> <p>Push the  button to set the display panel to 7 .</p> <p>Every time you push the  button, the display panel reads 0 → 1 → 2 → 3 → ..... → 9 → A → b → c → d → E → F repeatedly.</p>	
	<p><b>5</b> Push the  button to  .</p> <p>Push the  button to set the display panel to C .</p> <p>Every time you push the  button, the display panel reads 0 → 1 → 2 → 3 → ..... → 9 → A → b → c → d → E → F repeatedly.</p>	
	<p><b>6</b> Push the  button to set the display panel to 2 .</p> <p>Every time you push the  button, the display panel reads 0 → 1 → 2 → 3 → ..... → 9 → A → b → c → d → E → F repeatedly.</p>	

### 3-3 Setting Option Setup Method(continue)

	Feature	Display
	<p><b>7</b> Push the  button to  . Push the  button to set the display panel to <b>6</b>. Every time you push the  button, the display panel reads <b>0→1→2→3→.....→9→A→b→c→d→E→F</b> repeatedly.</p>	
	<p><b>8</b> Push the  button to set the display panel to <b>8</b>. Every time you push the  button, the display panel reads <b>0→1→2→3→.....→9→A→b→c→d→E→F</b> repeatedly.</p>	
	<p><b>9</b> Push the  button to  . Push the  button to set the display panel to <b>8</b>. Every time you push the  button, the display panel reads <b>0→1→2→3→.....→9→A→b→c→d→E→F</b> repeatedly.</p>	
	<p><b>10</b> Push the  button to set the display panel to <b>3</b>. Every time you push the  button, the display panel reads <b>0→1→2→3→.....→9→A→b→c→d→E→F</b> repeatedly.</p>	
	<p><b>11</b> Push the  button to  . Push the  button to set the display panel to <b>1</b>. Every time you push the  button, the display panel reads <b>0→1→2→3→.....→9→A→b→c→d→E→F</b> repeatedly.</p>	
	<p><b>12</b> Push the  button to  .</p>	
	<p><b>13</b> Push the  button to  .</p>	
	<p><b>14</b> Push the  button to  .</p>	

**Step 3 : Upon completion of the selection, check you made right selections.**

Press the Mode  Selection key to set the display part and check the display part.

➔ The display part shows like below when each time you press Mode button .

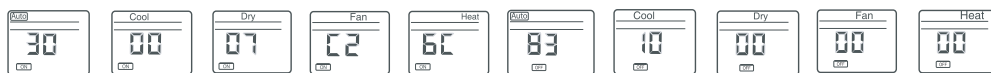

**Step 4 : Pressing the ON/OFF button (  )**

When pressing the operation ON/OFF key with the direction of remote control for unit, the sound "Ding" or "Diriring" is heard and the OPERATION ICON (  ) lamp of the display is flickering at the same time, then the input of option is completed. (If the diriring sound isn't heard, try again pressing the ON/OFF button.)

**Step 4 : Pressing the ON/OFF button (  )**

When pressing the operation ON/OFF key with the direction of remote control for unit, the sound "Ding" is heard and the OPERATION ICON(  ) lamp of the display is flickering at the same time, then the input of option is completed. (If the diriring sound isn't heard, try again pressing the ON/OFF button.)

**Step 5 : Unit operation test-run**

**First,** Remove the battery from the remote control.

**Second,** Re-insert the battery into the remote control.

**Third,** Press ON/OFF key with the direction of remote control for set.

**• Error Mode**

- 1<sup>st</sup> If all lamps of indoor unit are flickering, Plug out, plug in power plug again and press ON/OFF key to retry.
- 2<sup>nd</sup> If the unit is not working properly or all lamps are continuously flickering after setting the option code, see if the correct option code is set up for its model.

**■ OPTION ITEMS AQ-09VFUAGM/CV**

011425-17421D- 271A23-372520	034044-113047 200000-300000
---------------------------------	--------------------------------

**■ OPTION ITEMS AQ-12VFUAGM/CV**

011425-17423D- 272328-372520	034B4D-114753 200000-300000
---------------------------------	--------------------------------

**■ OPTION ITEMS AQ-18VFUAGM/CV**

012425-17423E- 27343C-37F620	034947-11484C 200000-300000
---------------------------------	--------------------------------

**■ OPTION ITEMS AQ-24VFUAGM/CV**

012425-18428C- 27444E-37F320	034F52-104C4C 200000-300000
---------------------------------	--------------------------------

**■ OPTION ITEMS AQ-36VFUAGM/CV**



01B425-17428C- 276063-37F520	034645-113533 200000-300000
---------------------------------	--------------------------------

---





## 4. Disassembly and Reassembly







---

### ■ Necessary Tools





Item	Remark
SCREW DRIVER	
MONKEY SPANNER	





## 4-1 Indoor Unit

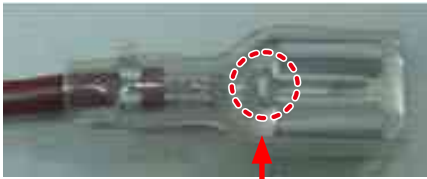



No	Parts	Procedure	Remak
1	PANEL-FRONT	<p>1) Stop the driving of air conditioner and shut main power supply.</p> <p>2) Open the FRONT-GRILLE and pull out from the PANEL-FRONT.</p> <p>3) Detach COVER-TERMINAL from the PANEL-FRONT.(use + Screw Driver )</p> <p>4) Loosen connector wire(white) and detach the temperature sensor wire .</p> <p>5) To detach the FRONT-PANEL the main frame, unfasten 2 screw at the bottom.(use + Screw Driver )</p> <p>6) Take off the FRONT-PANEL, lifting up the bot</p>	    





No	Parts	Procedure	Remark
2	TRAY DRAIN	<p>1) Loosen stepping motor wire and detach the hook of main frame.</p> <p>2) To detach TRAY-DRAIN from the main frame, pull the bottom of the TRAY-DRAIN towards you.</p>	 
3	CONTROL IN	<p>1) Unfasten the earth screw.(use + Screw Driver)</p> <p>2) Detach COVER-CONTROL from the CASECONTROL.</p> <p>3) Detach the temperature sensor.</p> <p>4) Loosen MOTOR Wire.</p> <p>5) Take off the CASE-CONTROL from the main frame.</p>	    







No	Parts	Procedure	Remark
4	PBA	1) Unfasten the screw.	
		2) Cut the cable tie.	
		3) Loosen the terminal block wires.  * Caution: The terminal is locking type. So, when you separate terminals, pull pressing the button.	 

No	Parts	Procedure	Remark
4	PBA	4) Loosen the Motor Feedback connector.  * Caution: When you separate the connector, pull pressing the locking button.	
		5) Loosen Stepping MOTOR connector.  * Caution: When you separate the connector, pull pressing the locking button.	
		6) Loosen Main Power connector.  * Caution: When you separate the connector, pull pressing the locking button.	
		7) Loosen the Thermistor wire connector.  * Caution: When you separate the connector, pull pressing the locking button.	
		8) Loosen the Relay connector(Red,White).	





No	Parts	Procedure	Remark
5	EVAPORATOR	<p>1) Unfasten the screw at the right side. (use + Screw Driver)</p> <p>2) Unfasten the screw at the left side. (use + Screw Driver)</p> <p>3) Detach the HOLDER PIPE.</p> <p>4) Take off the EVAPORATOR from the main frame.</p>	   



No	Parts	Procedure	Remark
6	FAN MOTOR & CROSS FAN	<p>1) Unfasten the screw in the HOLDER-EVAP on the left side of evaporator.(use + Screw Driver)</p> <p>2) unfasten the 3 points screws in the CASE-CONTROL, and then detach the CASE. (use + Screw Driver)</p> <p>3) unfasten the screw a little.(use + Screw Driver)</p> <p>4) Lift up the evaporator slightly and pull the CROSS-FAN to the left side.</p>	   

## 4-2 Outdoor Unit

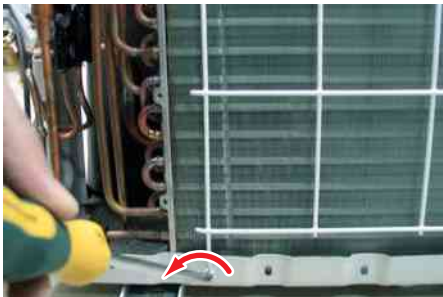

No	Parts	Procedure	Remark
1	Common Work	<p>1) Loosen 1 fixing screw(CCW) of the Cover-Control and detach the Cover Control.</p> <p>2) Loosen fixing screws(CCW) and detach the Cabinet-Upper.</p> <p>3) Loosen 1 screw(CCW) fixed to assemble Control Box with Cabinet-Side RH.</p> <p>4) Loosen 6 fixing screws(CCW) and detach the Cabinet-Side RH.</p>	   

No	Parts	Procedure	Remark
		<p>6) Loosen fixing screws(CCW) of the Cabinet Front.</p>	
		<p>5) Loosen 2 screws(CCW) fixed on the Guide Condenser.</p>	

No	Parts	Procedure	Remark
2	Fan ☒ Motor	<p>1) Detach the Nut Flange like the picture on the right side. (Turn clockwise because the screw is left-handed.)</p> <p>2) Detach the Fan Propeller.</p> <p>3) Loosen 4 fixing screws(CCW) to detach the Motor.</p> <p>4) Disconnect the wire between Ass'y Control Out and Motor.</p> <p>5) Loosen 2 fixing screws(CCW) and detach the Bracket Motor.</p>	   



No	Parts	Procedure	Remark
3	Ass'y Control Out	1) Detach several connectors from the Ass'y Control Out. 2) Detach several connectors from the PCB of Ass'y Control Out. 3) Pull up the Ass'y Control Out.	
4	Heat Exchanger	1) Release the refrigerant at first 2) Loosen fixing screw(CCW) and detach the steel bar. 3) Disassemble the pipes in both inlet and outlet with welding torck.  <b>⚠ Before you disassemble the pipes and Condenser, be sure that there should be no refrigerant remained in the unit.</b>	
		1) Loosen fixing screw(CCW) and detach the Heat Exchanger	





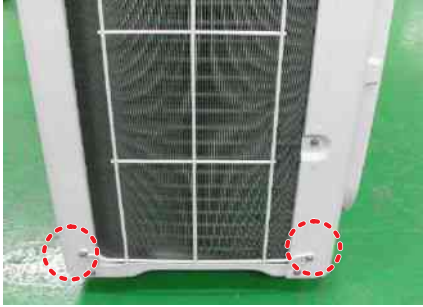

No	Parts	Procedure	Remark
5	Compressor	1) Disassemble the Felt Comp Sound. 2) Loosen the fixing nut(CCW) and detach the Compressor Lead Wire.	 
		3) Loosen the 3 bolts(CCW) at the bottom of Compressor like the picture on the right side.	

# AQX36VFUAGM/CV

No	Parts	Procedure	Remark
1	Common Work	<p>1) Loosen 2 fixing screws of the Cabi Front Rh and detach the Cabi Front Rh.</p> <p>2) Loosen each 8 fixing screws and detach the Cabi Top Cover.</p> <p>3) Loosen 17 screws fixed to assemble Control Box with Cabi Back Rh.</p>	   

No	Parts	Procedure	Remark
		4) Loosen 4 screws fixed on cond-bar.	
		5) Loosen 4 screws fixed on cond-bar.	
		6) Loosen 13 fixing screws of the Cabi Front Lf and detach it.	

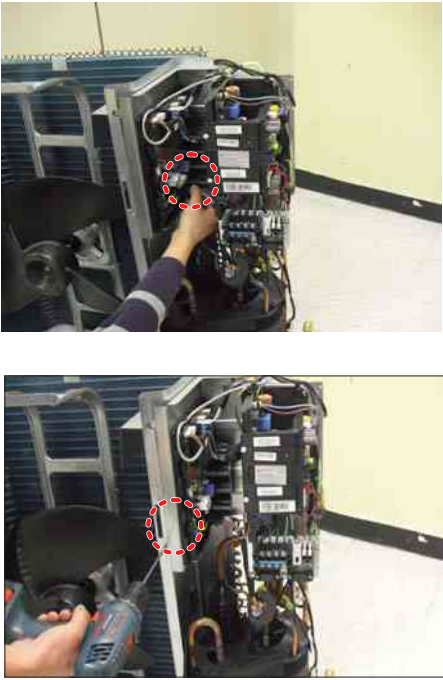
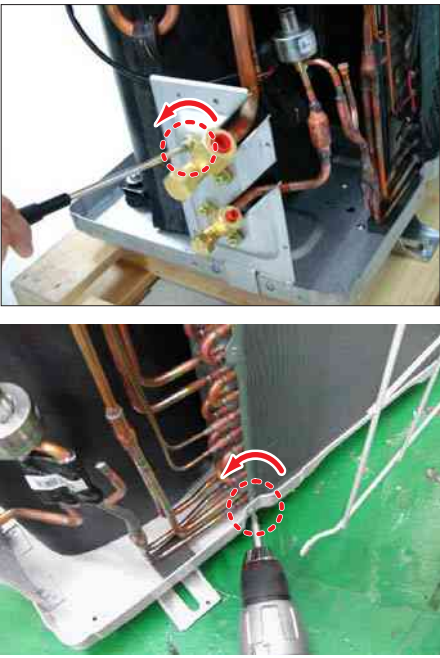

No	Parts	Procedure	Remark
2	Fan & Motor	<p>1) Detach the Nut Flange like the picture on the right side.(Turn clockwise because the screw is left-handed.) (Use Monkey Spanner.)</p> <p>2) Detach the Fan Propeller.</p> <p>3) Loosen 4 fixing screws to detach the Motor. (Use Monkey Spanner.)</p> <p>4) Disconnect the wire between Ass'y Control Out and Motor.</p> <p>5) Loosen 2 fixing bolts and detach the Bracket Motor.(Use Monkey Spanner.)</p>	   

No	Parts	Procedure	Remark
3	Ass'y Control Out	<ol style="list-style-type: none"> <li>1) Detach several connectors from the Ass'y Control Out.</li> <li>2) Detach several connectors from the PCB of Ass'y Control Out.</li> <li>3) Pull up the Ass'y Control Out.</li> </ol>	
4	Heat Exchanger	<ol style="list-style-type: none"> <li>1) Release the refrigerant at first.</li> <li>2) Loosen fixing screw on both sides.</li> <li>3) Disassemble the pipes in both inlet and outlet with welding torch.</li> <li>4) Detach the Heat Exchanger.</li> </ol>	

No	Parts	Procedure	Remark
5	Compressor	<ol style="list-style-type: none"> <li>1) Loosen the fixing nut and detach the Compressor Lead Wire. (Use Monkey Spanner.)</li>   <li>2) Disassemble the Felt Comp Sound.</li> <li>3) Loosen the 3 bolts at the bottom of Compressor like the picture on the right side.(Use Monkey Spanner.)</li> </ol>	

### 3.EEPROM DOWNLOAD

No	Parts	Procedure	Remark
1	Maldives High EER (only)	<p>1) Power off</p>           <p>2) Take off the Cabinet : Check the LED off</p>           <p>3) Connect PC-Download Jig-PBA</p>	    

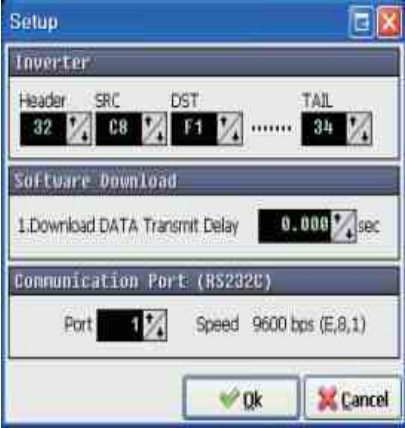
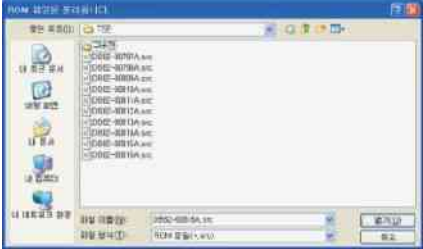
No	Parts	Procedure	Remark
1		<p>5) Execute the Universal EEPwriter program</p> <p>6) Select COM Port and connect</p> <p>7) Open the file</p>	    

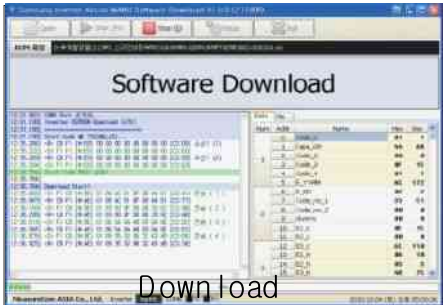
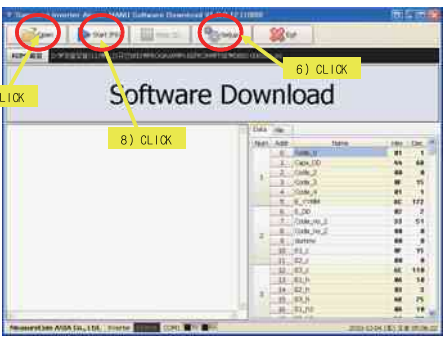

No	Parts	Procedure	Remark
1		8) Click the Start button and reset the power	  

## 5.Exploded views and Parts list

### 5-1 Indoor Unit

AQN09/12VFUAGM/CV

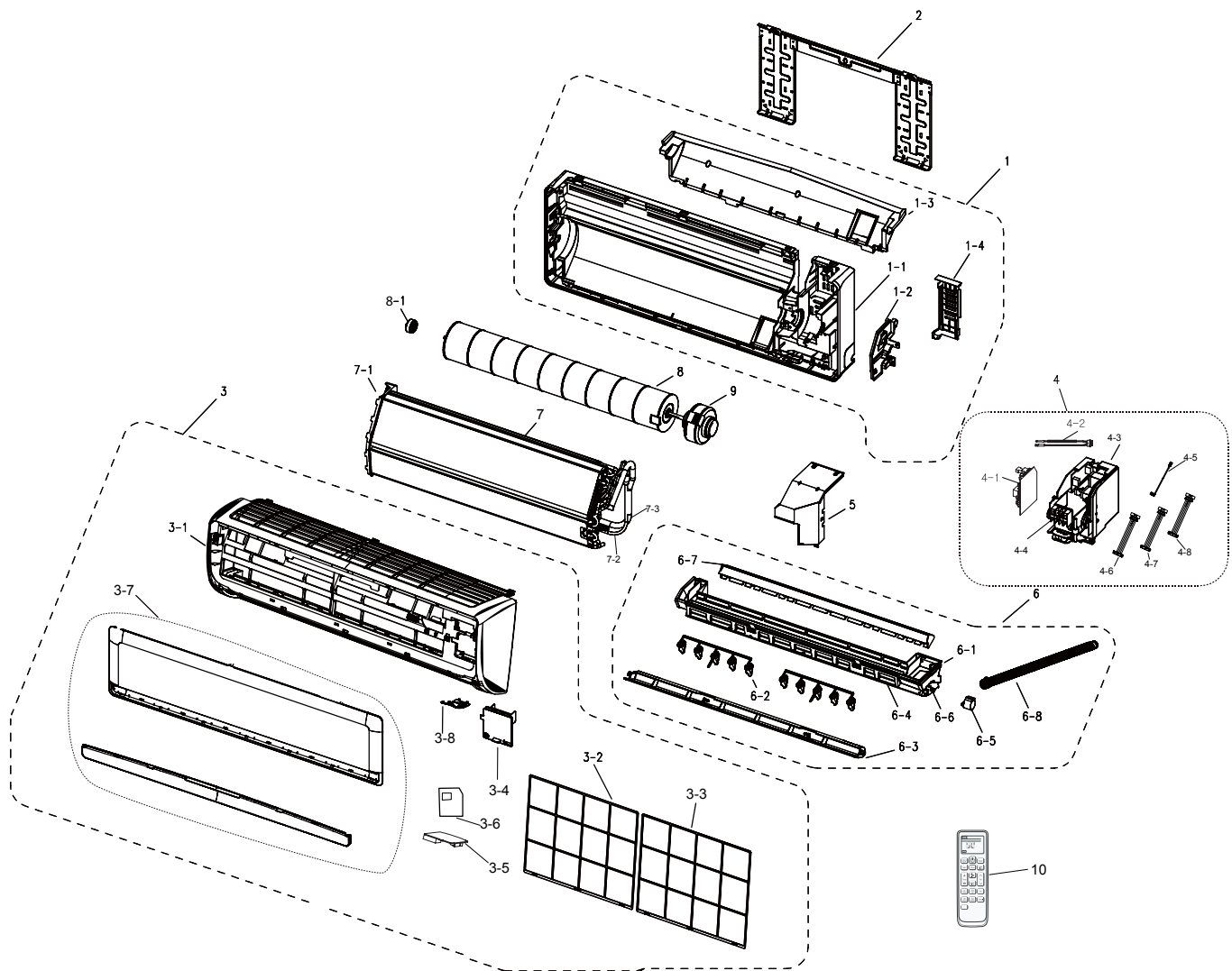

## ■ Parts List

No	Parts Code	Parts Description	Spec.	Q'ty		SA/SNA
				AQN09VF UAGM/CV	AQN12VF UAGM/CV	
1	DB94-01921R	ASSY BACK BODY	DA WHITE,R410A,Max 1,SSEC	1	1	SA
1-1	DB61-03656C	BODY BACK	VIVALDI,HIPS,2.5,-,820,286,WHITE,SSEC	1	1	SNA
1-2	DB61-03651B	SUPPORT-EVAP RH	VIVALDI,ABS,2,52.2,130.1,SSEC	1	1	SA
1-3	DB62-05888B	SEAL-INSUL BODY REAR	VIVALDI,EPS,WHITE,76,656,S-	1	1	SNA
1-4	DB61-03666A	HOLDER-PIPE	VIVALDI,HIPS,T2.0,63.5,183.7,SC-06106R,SSEC	1	1	SA
2	DB97-02851C	ASSY-PLATE HANGER	vivaldi 1,ssec	1	1	SA
3	DB92-02553C	ASSY PANEL FRONT	VIVALDIS 1,SSEC	1	1	SA
3-1	DB64-02124A	PANEL FRONT	VIVALDI-1,HIPS,2.5,286.6,820,-,SC-06106R	1	1	SA
3-2	DB63-02143H	FILTER-PRE L	VIVALDI 1,PP,T2.0,Light Gray(GY0262),SSEC	1	1	SA
3-3	DB63-02144H	FILTER-PRE R	VIVALDI 1,PP,T2.0,Light Gray(GY0262),SSEC	1	1	SA
3-4	DB97-11240C	ASSY COVER TERMINAL	VIVALDI 1,-,-,SSEC	1	1	SA
3-5	DB61-03648A	CASE PCB	VAVAI,ABS,2.0T,83.6,BLACK,SSEC	1	1	SNA
3-6	DB93-11009A	ASSY PCB SUB-DISPLAY	MAX,TR DRIVER,LED 3EA,N	1	1	SA
3-7	DB92-01405N	ASSY GRILLE	VIVALDI-1 ,STD,SSEC	1	1	SA
3-8	DB90-04305E	ASSY COVER DISPLAY	VIVALDI-1,SSEC	1	1	SA
4	DB93-12914C	ASSY CONTROL IN	INV,9-12K,KCV,SSEC	1	1	SNA
4-1	DB93-12827B	ASSY PCB MAIN-IN	STD#4,INV,AC MOTOR,SPI,12Y	1	1	SA
4-2	DB95-04570B	ASSY THERMISTOR IN	BORACAY	1	1	SA
4-3	DB61-04578A	CASE CONTROL-IN	Maldives,ABS+PC,GRAY,5VA,SSEC	1	1	SA
4-4	DB65-00326A	TERMINAL BLOCK-THERMAL FUSE	4P,PBT,4-TAB,4-SCREW,MAX	1	1	SA
4-5	DB93-10942A	ASSY CONNECTOR WIRE	JUNGFRAU-PJT,MAIN TO T/B	1	1	SA
4-6	DB93-10918H	ASSY CONNECTOR WIRE	MALDIVE	1	1	SA
4-7	DB93-10943H	ASSY CONNECTOR WIRE	MALDIVE	1	1	SA
4-8	DB93-10943P	ASSY CONNECTOR WIRE	INV	1	1	SA
5	DB90-04385A	ASSY COVER CONTROL IN	VIVALDI,SSEC	1	1	SA
6	DB94-01922K	ASSY TRAY DRAIN	WHITE,RH,1M,Y,-,VIVALDI,SSEC	1	1	SA
6-1	DB63-02118A	TRAY DRAIN	VIVALDI,HIPS,2.5,96,690,-,VIVALDI BLACK,SSEC	1	1	SNA
6-2	DB61-03672A	BLADE-V	VIVALDI-1,PP,BLACK,T2.0,SSEC	2	2	SA
6-3	DB61-03649A	BLADE-H	VIVALDI,ABS,WHITE,639.9*64.1,SSEC	1	1	SA
6-4	DB69-00839A	CUSHION-TRAY RH	SS-P/J,EPS,-,-,-,3g,WHITE,SSEC,RAC,AS	1	1	SNA
6-5	DB31-00371C	MOTOR STEP	24BYJ48,DC15V	1	1	SA
6-6	DB62-05900A	SEAL-TRAY RH	VIVALDI,FOAM-PE,GRAY,T5,32.5,64.3,SSEC	1	1	SNA
6-7	DB63-02121A	TRAY-STABILIZER	VIVALDI,HIPS,2.5,34.5,580,-,VIVALDI BLACK,SSEC	1	1	SNA
6-8	DB94-00458D	ASSY HOSE DRAIN	WHITE,LFET,550,Y,R410,-,-,SSEC	1	1	SA
7	DB96-11359B	ASSY EVAP TOTAL	AQV12PWAN,SSEC	1	1	SA
7-1	DB61-03650A	HOLDER-EVAP	VIVALDI,HIPS,2,41.8,146.9,SR-03101R,SSEC	1	1	SNA
7-2	DB96-11326C	ASSY TUBE EVAP IN	SSEC	1	1	SA
7-3	DB96-11683C	ASSY TUBE EVAP OUT	VIVALDI,SSEC	1	1	SA
8	DB94-01874A	ASSY-CROSS FAN	VIVALDI,SSEC	1	1	SA
8-1	DB94-00455B	ASSY-RUBBER BEARING	WW-PJT,CR,BLK SSEC	1	1	SA
9	DB31-00531C	MOTOR FAN	Y4S476A55,vivaldi-PJT,0.15A,60Hz,31W,-,1750,60HZ,220V,-,-,Bclass	1	1	SA
10	DB93-11115Y	ASSY REMOCON	ARH-5022,MALDIVES, BORACAY, MAX USA	1	1	SA

## 5.Exploded views and Parts list

### 5-1 Indoor Unit

AQN18/24VFUAGM/CV

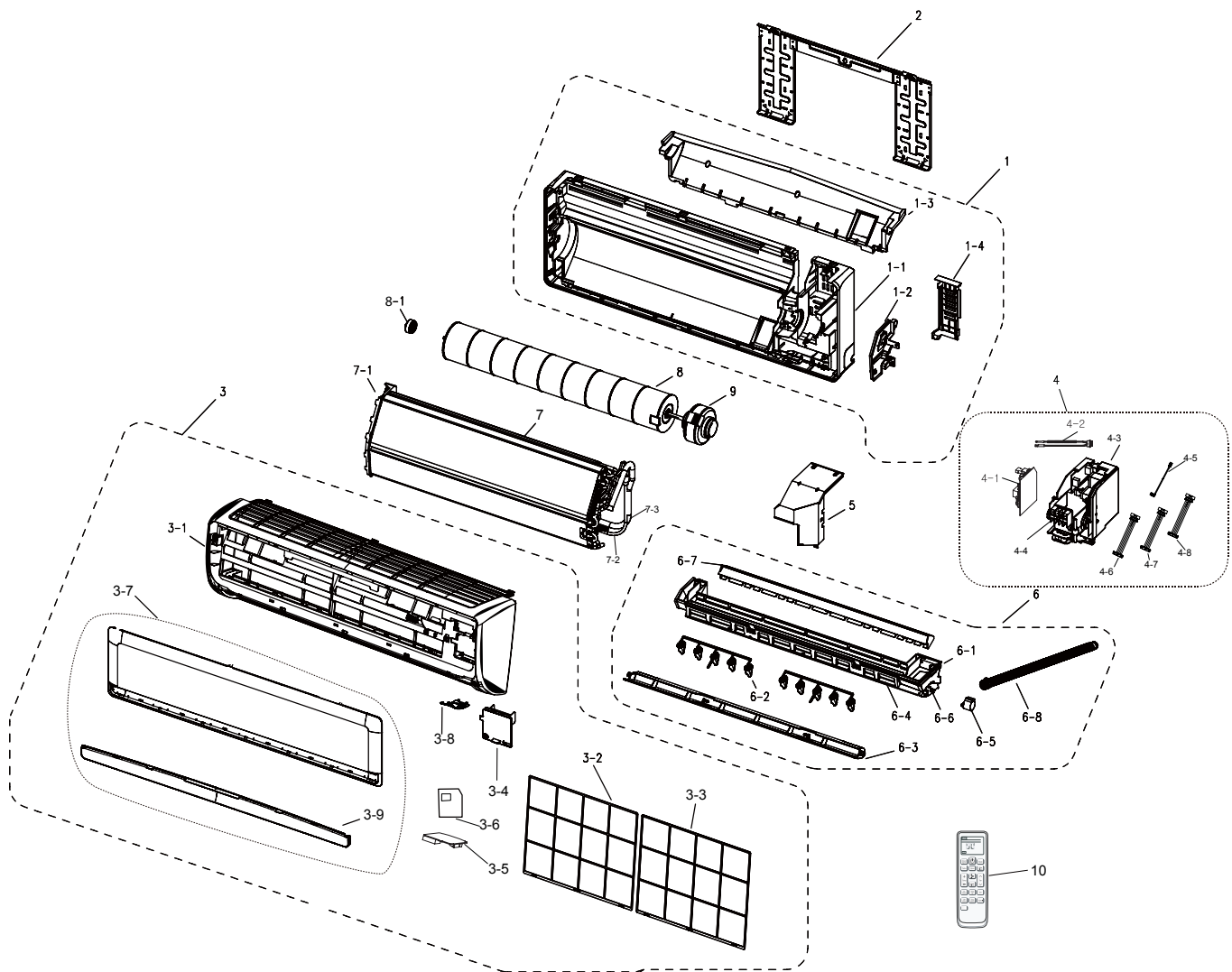

## ■ Parts List

No	Parts Code	Parts Description	Spec.	Q'ty		SA/SNA
				AQN18VF UAGM/CV	AQN24VF UAGM/CV	
1	DB94-00615J	ASSY BACK BODY	WHITE,AQN18VFUAGM/CV,SSEC	1	1	SA
1-1	DB61-04681A	BODY BACK	BORACAY,HIPS,2.5,-,1065,298,white,SSEC	1	1	SNA
1-2	DB90-04857A	ASSY-SUPPORT EVAP	VIVALDI,SSEC	1	1	SA
1-3	DB69-01039A	CUSHION-BACK BODY	AQT24W6WE,EPS,WHITE,RAC,AH	1	1	SNA
1-4	DB61-01977A	BRACKET-EVAP	AQT24W6WE,SGCC-M,0.8,-,-,-	1	1	SA
2	DB90-02738A	ASSY-PLATE HANGER	WW2,SSEC	1	1	SA
3	DB92-02645B	ASSY PANEL FRONT	SSEC	1	1	SA
3-1	DB64-02128A	PANEL FRONT	VIVALDI-3,HIPS,T2.2,300.6,1065,WHITE,SSEC	1	1	SA
3-2	DB63-02129H	FILTER-PRE L	VIVALDI-3 EUR,PP,2.0,422.9,283.5,LIGHT GRAY GY0262,silk screen:SAMSUNG	1	1	SA
3-3	DB63-02130H	FILTER-PRE R	VIVALDI-3 EUR,PP,2.0,422.9,283.5,LIGHT GRAY GY0262,SILK SCREEN: SAMSUNG	1	1	SA
3-4	DB97-11889A	ASSY COVER TERMINAL	VIVALDI 1,-,-,-,SSEC	1	1	SA
3-5	DB61-03648A	CASE PCB	VAVAI,ABS,2.0T,83.6,BLACK,SSEC	1	1	SNA
3-6	DB93-11009A	ASSY PCB SUB-DISPLAY	MAX,TR DRIVER,LED 3EA,N	1	1	SA
3-7	DB92-01398N	ASSY GRILLE	VIVALDIS 3,SSEC	1	1	SA
3-8	DB90-04301C	ASSY COVER DISPLAY	VIVALDI-3,SSEC	1	1	SA
3-9	DB64-02132D	DECORATION-GRILLE	VIVALDI3 EUR,HIPS,37.5,1011.6,15.6,PM Gray GY0096,SSEC	1	1	SA
4	DB93-12915H	ASSY CONTROL IN	HP,INV,24K,MALDIVE3,AQN18VFUAGM/CV	1	1	SNA
4-1	DB93-12828C	ASSY PCB MAIN-IN	STD#5,INV,BLDC MOTOR,12Y KCV,SPI,Y,SMPS, TOP253P	1	1	SA
4-2	DB95-04570B	ASSY THERMISTOR IN	BORACAY	1	1	SA
4-3	DB61-04576A	CASE CONTROL-IN	MALDIVES-3,PC+ABS,T2.0,142,220.1,GRAY	1	1	SA
4-4	DB65-00326A	TERMINAL BLOCK-THERMAL FUSE	4P,PBT,4-TAB,4-SCREW,MAX	1	1	SA
4-5	DB93-10942A	ASSY CONNECTOR WIRE	JUNGFRAU-PJT,MAIN TO T/B	1	1	SA
4-6	DB93-10918H	ASSY CONNECTOR WIRE	MALDIVE	1	1	SA
4-7	DB93-10943H	ASSY CONNECTOR WIRE	MALDIVE	1	1	SA
4-8	DB93-10943P	ASSY CONNECTOR WIRE	INV	1	1	SA
5	DB90-06284A	ASSY COVER CONTROL IN	BORACAY3,SSEC	1	1	SA
6	DB94-01925M	ASSY TRAY DRAIN	WHITE,RH,550mm,Y,R22,-,VIDD-3,SSEC	1	1	SA
6-1	DB63-01071A	TRAY-DRAIN	AQT24W6WE,HIPS,T2.5,BLACK	1	1	SA
6-2	DB61-03660A	BLADE-V	VIVALDI-3,PP,BLACK,T2.0,SSEC	2	2	SA
6-3	DB61-03661A	BLADE-H	VIVALDI-3,ABS,WHITE,877.3, T2.5,SSEC	1	1	SA
6-4	DB69-01024A	CUSHION	AQT24W6WE,EPS,WHITE,RAC,AH	1	1	SNA
6-5	DB31-00370B	MOTOR STEP	35BYJ46,DC15V	1	1	SA
6-6	DB62-02941A	SEAL-TRAY RH A	WW2-P/J,FOAM-PE,GRAY,T5,R-	1	1	SNA
6-7	DB63-01066A	TRAY-STABILIZER	AQT24W6WE,HIPS,T2.0,L819.4,BLACK	1	1	SNA
6-8	DB94-00458D	ASSY HOSE DRAIN	WHITE,LFET,550,Y,R410,-,-,SSEC	1	1	SA
7	DB96-11950S	ASSY EVAP TOTAL	AQV18EWD,SSEC	1	1	SA
7-1	DB63-01065A	COVER-BEARING	AQT24W6WE,ABS,2.5,-,-,-,BLACK,-	1	1	SNA
7-2	DB96-11547A	ASSY TUBE EVAP IN	vivaldi 3,SSEC	1	1	SA
7-3	DB96-11682J	ASSY TUBE EVAP OUT	RAC,SSEC	1	1	SA
8	DB94-01556B	ASSY-CROSS FAN	VIVALDI,SSEC	1	1	SA
8-1	DB94-00455B	ASSY-RUBBER BEARING	WW-PJT,CR,BLK SSEC	1	1	SA
9	DB31-00609A	MOTOR FAN	SIC-41CVJ,27[W],DC310V,CLASS E	1	1	SA
10	DB93-11115Y	ASSY REMOCON	ARH-5022,MALDIVES, BORACAY, MAX USA	1	1	SA

## 5.Exploded views and Parts list

### 5-1 Indoor Unit

AQN36VFUAGM/CV

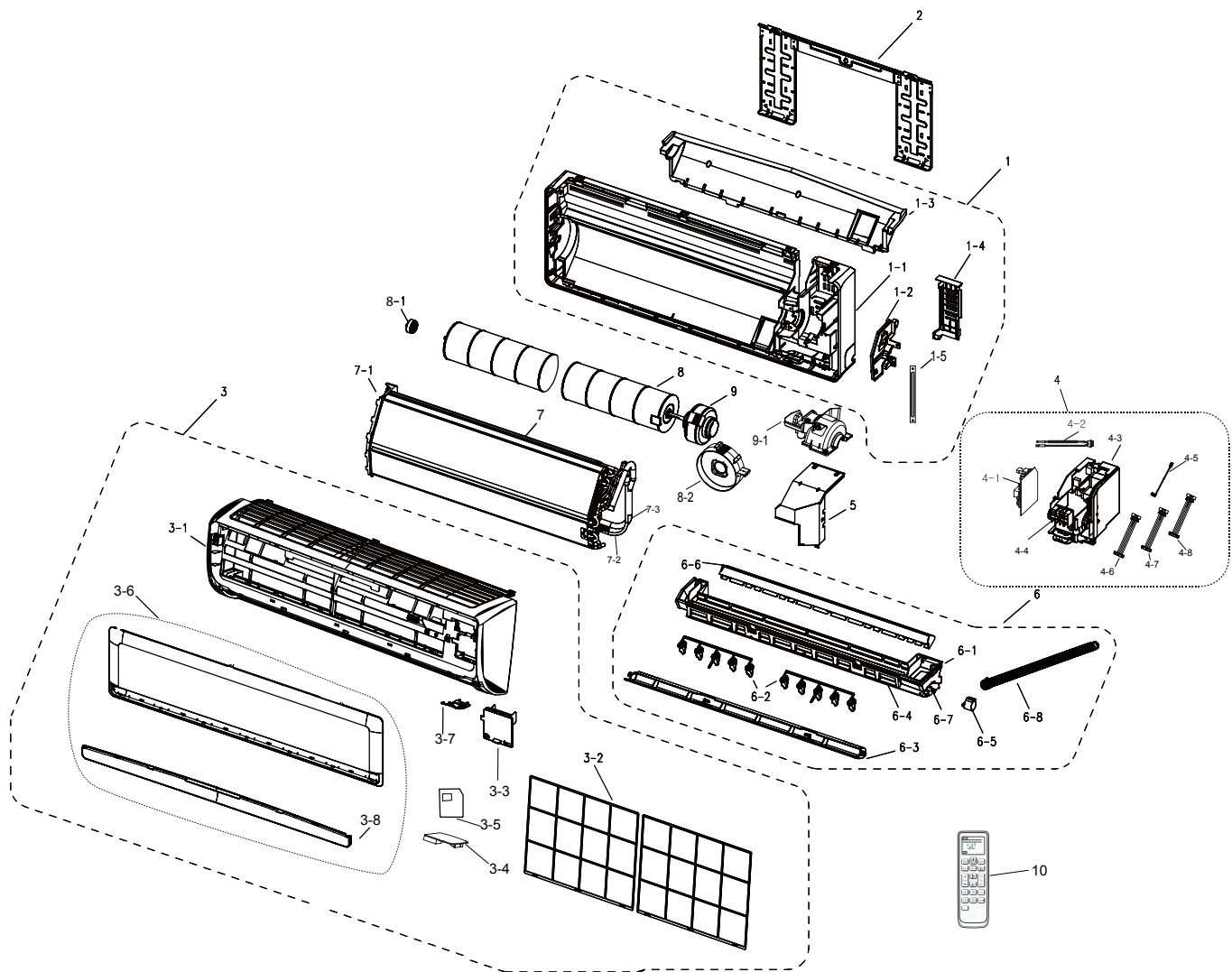

## Part List

No	Parts Code	Parts Description	Spec.	Q'ty	SA/SNA
				AQN36VF UAGM/CV	
1	DB94-01498G	ASSY BACK BODY	DA WHITE,R410A,MAX 4,SSEC	1	SA
1-1	DB61-03208B	BODY-BACK	WW3,HIPS,2.5,345,1280,SC-06106R,SSEC	1	SNA
1-2	DB90-03402A	ASSY-SUPPORT EVAP	WW3,SSEC	1	SA
1-3	DB61-03215A	BODY BACK-CUSHION	WW3,CUSHION,64.8,-,1049.4,121.1,WHITE,SSEC	1	SNA
1-4	DB61-03218B	HOLDER-PIPE	WW3,ABS,1.5,25,216,DA-WHITE,SSEC	1	SA
1-5	DB61-03250A	HOLDER-BODY BACK	WW3,SGCC-M,1.0,14,151,WHITE,SSEC	1	SA
2	DB70-00787A	PLATE-HANGER	WW3,SGCC-M,0.8,303.25,1010.5,SSEC	1	SA
3	DB92-02107W	ASSY PANEL FRONT	WHT,R410A,DA WHITE,max4,SSEC	1	SA
3-1	DB64-02517A	PANEL FRONT	VIVALDI-3,HIPS,T2.2,WHITE,SSEC	1	SA
3-2	DB63-01765F	GUARD-AIR FILTER	MAX4,PP,LIGHT GRAY GY0262,SSEC	2	SA
3-3	DB90-07397A	ASSY COVER-TERMINAL	MAX4,WIRED REMOCON,SSEC	1	SA
3-4	DB61-03648A	CASE PCB	VAVAIDI,ABS,2.0T,83.6,BLACK,SSEC	1	SNA
3-5	DB93-11009A	ASSY PCB SUB-DISPLAY	MAX,TR DRIVER,LED 3EA,N	1	SA
3-6	DB92-02101G	ASSY GRILLE	MAX4,SSEC	1	SA
3-7	DB90-05771A	ASSY COVER DISPLAY	WW3-MAX,SSEC	1	SA
3-8	DB64-02515E	DECORATION-GRILLE	MAX4,HIPS,41,1229,18,GY0096; PM	1	SA
4	DB93-09711A	ASSY CONTROL IN	hp,INV,KCV,SSEC	1	SNA
4-1	DB93-12828C	ASSY PCB MAIN-IN	STD#5,INV,BLDC MOTOR,12Y KCV,SPI,Y,SMPS,TOP253P	1	SA
4-2	DB95-01990F	ASSY THERMISTOR IN	HP,INV	1	SA
4-3	DB61-04464A	CASE CONTROL-IN	WW3-MAX,HIPS,T2.0,BLACK,ssec	1	SNA
4-4	DB65-00326A	TERMINAL BLOCK-THERMAL FUSE	4P,PBT,4-TAB,4-SCREW,MAX	1	SA
4-5	DB93-10942A	ASSY CONNECTOR WIRE	JUNGFRAU-PJT,MAIN TO T/B	1	SA
4-6	DB93-10918H	ASSY CONNECTOR WIRE	MALDIVE	1	SA
4-7	DB93-10943H	ASSY CONNECTOR WIRE	MALDIVE	1	SA
4-8	DB93-10943P	ASSY CONNECTOR WIRE	INV	1	SA
5	DB90-05839A	ASSY COVER-PCB	INV,SSEC	1	SA
6	DB94-01495D	ASSY TRAY DRAIN	WHITE,RH,1M,Y,R22,-,EXPORT,SSEC	1	SA
6-1	DB63-01755A	TRAY DRAIN	WW3,ABS,2.0,123,1076,-,SC-06106R,SSEC	1	SA
6-2	DB61-03254A	BLADE-V A	WW3,PP,BLACK,79*49*5.5,SSEC	2	SA
	DB61-03255A	BLADE-V B	WW3,PP,BLACK,79*49*5.5,SSEC	10	SA
6-3	DB61-04465A	BLADE-H	WW3-MAX,ABS,WHITE,1068.5, T2.5,SSEC	1	SA
6-4	DB63-01760A	TRAY-CUSHION UP	WW3,PS,24.2,52.4,537.3,-,WHITE,SSEC	2	SNA
6-5	DB31-00369B	MOTOR STEP	35BYJ46,-,-,-,-,DC12V,-,-,-,-10~40,- .DC12V,1500gf.cm, SMH250-05L(WHT),100±20mm	1	SA
6-6	DB62-05060A	SEAL-TRAY RH A	WW3,FOAM-PE,GRAY,10,35.2,116.7,SSEC	1	SNA
6-7	DB63-01760A	TRAY-CUSHION UP	WW3,PS,24.2,52.4,537.3,-,WHITE,SSEC	2	SNA
6-8	DB94-00458D	ASSY HOSE DRAIN	WHITE,LFET,550,Y,R410,-,-,SSEC	1	SA
7	DB96-09872H	ASSY EVAP TOTAL	AQV30UWCNXSA,SSEC	1	SA
7-1	DB61-03205A	BRACKET EVAP	WW3,SGCC-M,0.8,44.9,100.3,BLACK,SSEC	1	SA
7-2	DB96-09870A	ASSY TUBE EVAP IN	KCV,SSEC	1	SA
7-3	DB96-11295B	ASSY TUBE EVAP OUT	AQV30UWCNXSA,SSEC	1	SA
8	DB94-00118A	ASSY FAN-CROSS R	B-P/J,CHINA	1	SA
	DB94-00119A	ASSY FAN-CROSS L	B-P/J,CHINA	1	SA
8-1	DB94-00455B	ASSY-RUBBER BEARING	WW-PJT,CR,BLK SSEC	1	SA
8-2	DB90-03401A	ASSY HOLDER-FAN	WW3,SSEC	1	SA
9	DB31-00332C	MOTOR FAN	SIC-55CVL-F158-1,-,-,-,-,-,-,-,-,0V,E,YH396- 06VRT/YT396B-RT,250	1	SA
9-1	DB61-03200A	HOLDER-MOTOR	WW3,ABS,1.5,145,180.1,WHITE,SSEC	1	SA
10	DB93-11115Y	ASSY REMOCON	ARH-5022,MALDIVES, BORACAY, MAX USA	1	SA

# 5-2 Outdoor Unit

AQX09/12/18VFUAGM/CV

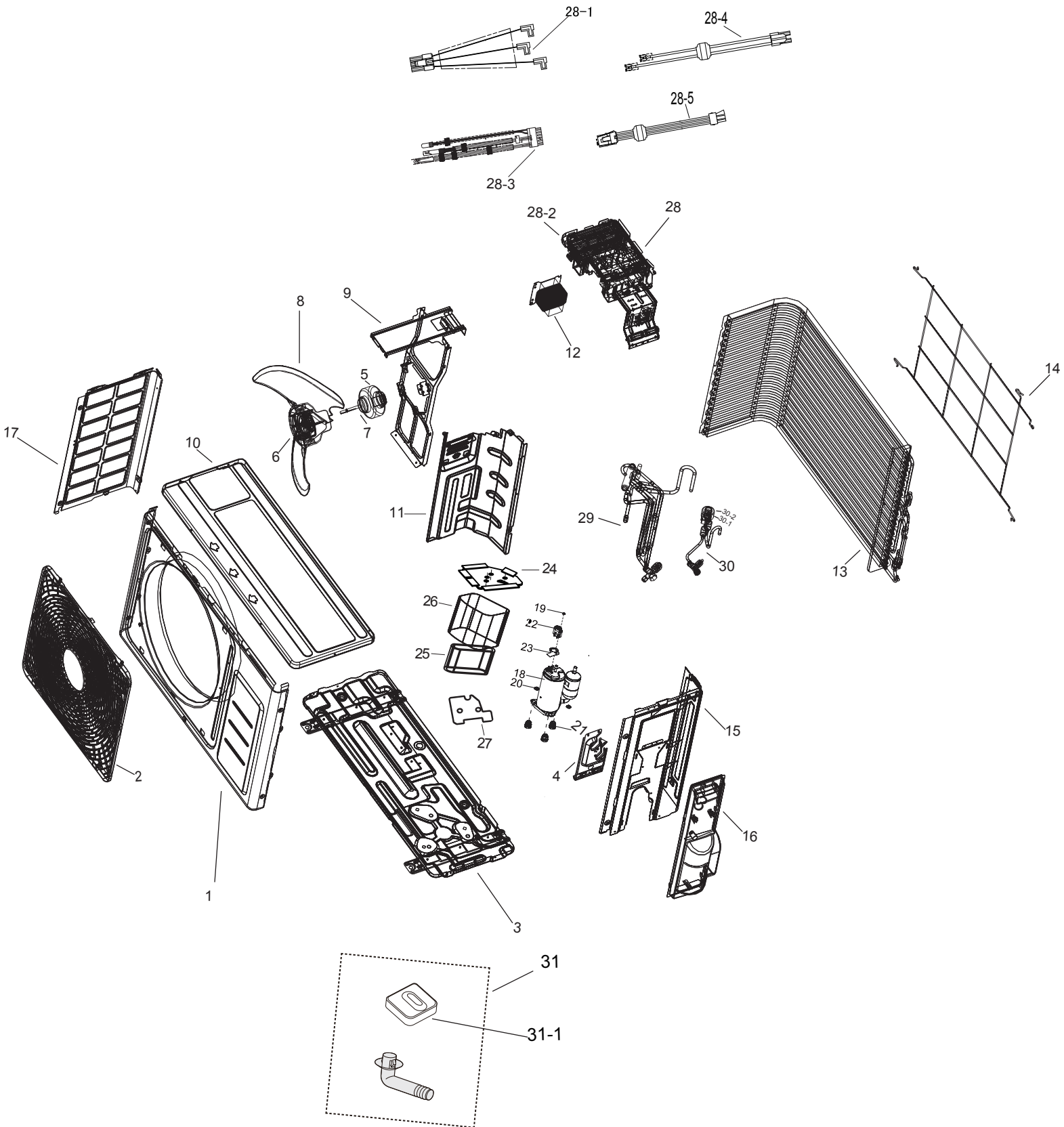



## ■ Parts List

No	Parts Code	Parts Description	Spec.	Q'ty	Q'ty	Q'ty	SA/SNA
				AQX09VF UAGM/CV	AQX12VF UAGM/CV	AQX18VF UAGM/CV	
1	DB90-07377A	ASSY CABI FRONT	AQV12UGAXKCV,EARTH BROWN	1	1	1	SA
2	DB63-02588B	GUARD FAN	SI-PJT,PP,T2.5,512.2,459.2,SSEC	1	1	1	SA
3	DB90-07141A	ASSY BASE OUT	maldives1,SSEC	1	1	1	SA
4	DB90-05738B	ASSY BRACKET-VALVE	AQ18UUAMID,RAC,SSEC	1	1	1	SA
5	DB31-00610C	MOTOR FAN	FMD6531SSBA,50[W],DC310V,CLASS E	1	1	1	SA
6	DB67-01042A	FAN-PROPELLER	NON-INV,PP-(GF+PD)40,410PI,SSEC	1	1	1	SA
7	6009-001001	SCREW-SPECIAL	TH,+,WT,M4,L10,ZPC(WHT),SWRCH18A	2	2	2	SNA
8	DB60-30020A	NUT-HEXAGON FLANGE	M6,Zn-Ni,MSWR3,CLOCKWISE	1	1	1	SA
9	DB90-06219B	ASSY BRACKET MOTOR	MALDIVES1,SSEC	1	1	-	SA
	DB90-06219D	ASSY BRACKET MOTOR	MALDIVES3,SSEC	-	-	1	SA
10	DB90-07376A	ASSY CABINET-UPPER	AQV12UGAXKCV,EARTH BROWN	1	1	1	SA
11	DB94-02998B	ASSY PARTITION	SI-PJT,SSEC	1	1	1	SA
12	DB27-00041B	COIL CHOKE	Forfe,5mH,10%,120mOHM,,10A,94.5*94*55	1	1	1	SA
13	DB96-15014A	ASSY COND	MALDIVES,SSEC	1	1	-	SA
	DB96-15137A	ASSY COND	SI-PJT,SSEC	-	-	1	SA
14	DB90-07144A	ASSY-SCREEN COND BAR	SI-PJT,SSEC	1	1	1	SA
15	DB90-07379A	ASSY CABI RH	AQV12UGAXKCV,EARTH BROWN	1	1	1	SA
16	DB90-07140A	ASSY COVER-VALVE	AQ18UUBMID,ASSY	1	1	1	SA
17	DB90-07378A	ASSY CABI LF	AQV12UGAXKCV,EARTH BROWN	1	1	1	SA
18	UG9A090FUBJPSS	RCP,39,F,R410A	RCP,39,F,R410A	1	1	-	SA
	UG4T150FUDJQSS	RCP,44,F,R410A	RCP,44,F,R410A	-	-	1	SA
19	DB60-30020A	NUT-HEXAGON FLANGE	M6,Zn-Ni,MSWR3,CLOCKWISE	1	1	1	SA
20	DB60-30028A	NUT-FLANGE	HWH,M8,ZPC(WHT),SWRCH18A,P1.25/Wa sher Type(WP)	3	3	3	SNA
21	DB63-00817B	GASKET	A/C model,SIR,T0.8,26.0,L80,A/C model use	1	1	1	SA
22	DB63-02310A	COVER TERMINAL	SABIC N1250,2.5,BLACK,no OLP	1	1	1	SA
23	DB63-02426A	GROMMET ISOLATOR	VIVALDI2,NR,37,15,INVERTER	1	1	1	SNA
24	DB63-02863A	FELT-COMP UPPER OUT	SI,FELT+PVC,T5(FELT)+T1.6(PVC),210,210, GRAY,SSEC	1	1	1	SA
25	DB63-02863A	FELT-COMP UPPER OUT	SI,FELT+PVC,T5(FELT)+T1.6(PVC),210,210, GRAY,SSEC	1	1	1	SA
26	DB63-02860A	FELT-COMP SIDE OUT	SI,FELT+PVC,T5(FELT)+T1.6(PVC),330,850, GRAY,SSEC	1	1	1	SA
27	DB63-02864A	FELT-COMP BASE	SI,FELT,T5,243.3,256,GRAY,SSEC	1	1	1	SA
28	DB93-10960K	ASSY CONTROL OUT	HP,INV,9/12/18K,50/60Hz,A &	1	1	-	SA
	DB93-10960L	ASSY CONTROL OUT	ASSY CONTROL	-	-	1	SA
28-1	DB93-12849A	ASSY CONNECTOR WIRE-COMP	AQV09PSBX,AWG#16	1	1	-	SA
	DB93-12849B	ASSY CONNECTOR WIRE-COMP	AQV09PSBX,AWG#1	-	-	1	SA
28-2	DB61-04658A	CASE CONTROL-OUT	WB,PC+ABC- FR(40),5V,T2,183.5,256.6,BLACK,TSE	1	1	1	SA
28-3	DB95-04637D	ASSY THEMISTOR	CAC,SSEC	1	1	1	SA
28-4	DB93-09493F	ASSY CONNECTOR WIRE	MALDIVE,SSEC	1	1	1	SA
28-5	DB93-09497C	ASSY CONNECTOR WIRE	MALDIVE,SSEC	1	1	1	SA
29	DB96-16885A	ASSY-VALVE 4WAY	MALDIVES1,SSEC	1	1	-	SA
	DB96-15136A	ASSY-VALVE 4WAY	HP,INV,SI-PJT,SSEC	-	-	1	SA
29-1	DB62-02284A	VALVE SERVICE	G2-P/J,-,3/8",-,SSEC	1	1	-	SA
	DB62-09656A	VALVE SERVICE	1/2",C3771,K-Type,4.2MPa	-	-	1	SA
30	DB96-18254A	ASSY-EEV	HP,INV,MALDIVES1,SSEC	1	1	-	SA
	DB96-15135A	ASSY-EEV	HP,INV,SI-PJT,SSEC	-	-	1	SA
30-1	DB62-04266A	VALVE-EXPAN	SUS, 1. 4, 500	1	1	-	SA
	DB62-09652A	VALVE SERVICE	1/4",C3771,K-Type,4.2MPa	-	-	1	SA
30-2	DB62-11205F	VALVE COIL EXPAN	DC12V, COIL, 500, 15. 45, MOLDING,	1	1	-	SA
	DB62-05932B	VALVE-EXPANSION COIL	QA(A)12-SXK-08-RK	-	-	1	SA
31	DB97-02066C	ASSY ACCESSORY	HP,NO,18000,NO,-,N,SH18AW6X,SSEC	1	1	1	SA
31-1	DB73-20134A	RUBBER-LEG	NBR,BLACK	4	4	4	SA

# 5-2 OUTDOOR UNIT

AQX24VFUAGM/CV

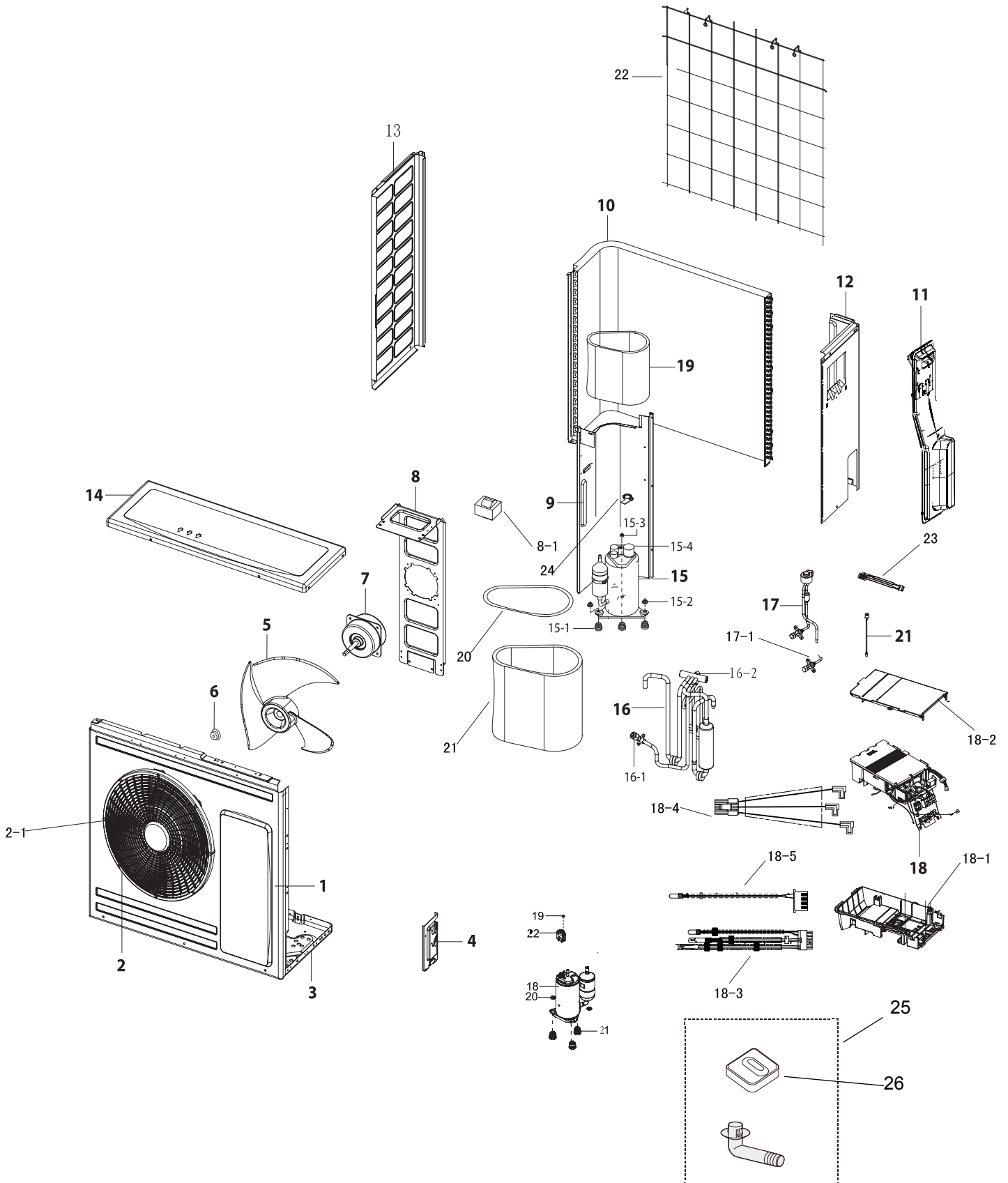

## ■ Parts List

No	Parts Code	Parts Description	Spec.	Q'ty	SA/SNA
				AQX24VF UAGM/CV	
1	DB90-07186R	ASSY CABI FRONT-TOTAL	P CHASSIS,SSEC	1	SA
2	DB63-02226D	GUARD FAN	GUARD FAN,PP+GF,SSEC	1	SA
3	DB90-07134H	ASSY BASE OUT-TOTAL	AQV24PSBX,FAC,SSEC	1	SA
4	DB61-01593C	BRACKET-VALVE	P/Q,SECC-	1	SA
5	DB67-00861A	FAN-PROPELLER	WW3,AS+GF20%,460,3,T3.5,SSE	1	SA
6	DB60-30020A	NUT-HEXAGON FLANGE	M6,Zn-Ni,MSWR3,CLOCKWISE	1	SA
7	DB31-00512F	MOTOR FAN	FMBC531SSK,124[W],1050RPM,D C310V,MAX IC 85°C,1500mm ,	1	SA
8	DB90-04194D	ASSY BRACKET MOTOR	KFRD-72W/MSD,FAC,SSEC	1	SA
8-1	DB27-00043C	COIL CHOKE-REACTOR	forte,5mH,5%,20A	1	SA
9	DB94-03086A	ASSY PARTITION	maldive,SSEC	1	SA
10	DB96-14021B	ASSY COND UNIT	Maldives3,SSEC	1	SA
11	DB90-07187A	ASSY-COVER VALVE	P Chassis,SSEC	1	SA
12	DB90-07225N	ASSY-CABI SIDE RH	P CHASSIS,SSEC	1	SA
13	DB90-07136C	ASSY CABINET-SIDE LF PAINT	AQ25VBFXHAC,ASSY SECC-P	1	SA
14	DB90-07133A	ASSY CABINET-UP	MH060,SSEC	1	SA
15	UG4T200FUAE4SS	RCP,44,F,R410A	RCP,44,F,R410A	1	SA
15-1	DB63-02296A	GROMMET ISOLATOR	-,NR,-,- ,32.5,ID11.5,OD34.0,BLACK,SSEC	3	SNA
15-2	6009-001369	SCREW-HEX	HEX,+WP,M4,L12,NI PLT,SWRCH18A,2,PVC WASHER(D10)	4	SNA
15-3	DB60-30020A	NUT-HEXAGON FLANGE	M6,Zn-Ni,MSWR3,CLOCKWISE	1	SA
15-4	DB63-02310A	COVER TERMINAL	SABIC N1250,2.5,BLACK,no OLP	1	SA
16	DB96-15081D	ASSY-VALVE 4WAY	HP,INV,R410,P CHASSIS	1	SA
16-1	DB62-09658A	VALVE SERVICE	5/8",C3771,K-Type,4.2MPa,R410A, HNBR	1	SA
16-2	DB62-02338A	VALVE-4WAY	R410A,ASSY,-,-,-,2HP	1	SNA
17	DB99-01005B	ASSY VALVE EEV	Maldives3,SSEC	1	SA
17-1	DB62-09652A	VALVE SERVICE	1/4",C3771,K-Type,4.2MPa,R410A / HNBR	1	SA
18	DB93-10961A	ASSY CONTROL OUT	HP,INV,24/30K,50Hz,150,A & C,VENICE	1	SA
18-1	DB61-04908A	CASE CONTROL-OUT	Q CHASSIS,ABS,GRAY,5V,SSEC	1	SNA
18-2	DB61-04910A	CASE CONTROL-UPPER	Q CHASSIS,ABS,DARK GRAY,5V,SSEC	1	SNA
18-3	DB95-04636D	ASSY-THERMISTOR	CAC,SSEC	1	SA
18-4	DB93-12849B	ASSY CONNECTOR WIRE-COMP	AQV09PSBX,AWG#14	1	SA
18-5	DB95-04635C	ASSY THEMISTOR	RAC,SSEC	1	SA
19	DB63-02868A	FELT-COMP SIDE	P Chassis,FELT,5,280,555,GRAY,SS	1	SA
20	DB63-02869A	FELT-COMP UPPER OUT	P Chassis,FELT+PVC,5,225,230,GR AY,SSEC	1	SA
21	DB63-02870A	FELT-COMP SIDE OUT	P Chassis,FELT+PVC,5,380,780,GR AY,SSEC	1	SA
22	DB63-03321A	GUARD COND-BAR	UP080EAV,HSWR-SWRH	1	SA
23	DB81-00635A	SPRING ETC-SENSOR	DVM- SYSTEM,STS304,R2.5,R4.5,44,0. 3,2.0,NONE	1	SNA
24	DB63-00817B	GASKET	A/C model,SIR,T0.8,26.0,L80,A/C model use	1	SA
25	DB97-02066C	ASSY ACCESSORY	HP,NO,18000,NO,- ,N,SH18AW6X,SSEC	1	SA
26	DB73-20134A	RUBBER-LEG	NBR,BLACK	4	SA

# 5-2 Outdoor Unit

AQX36VFUAGM/CV

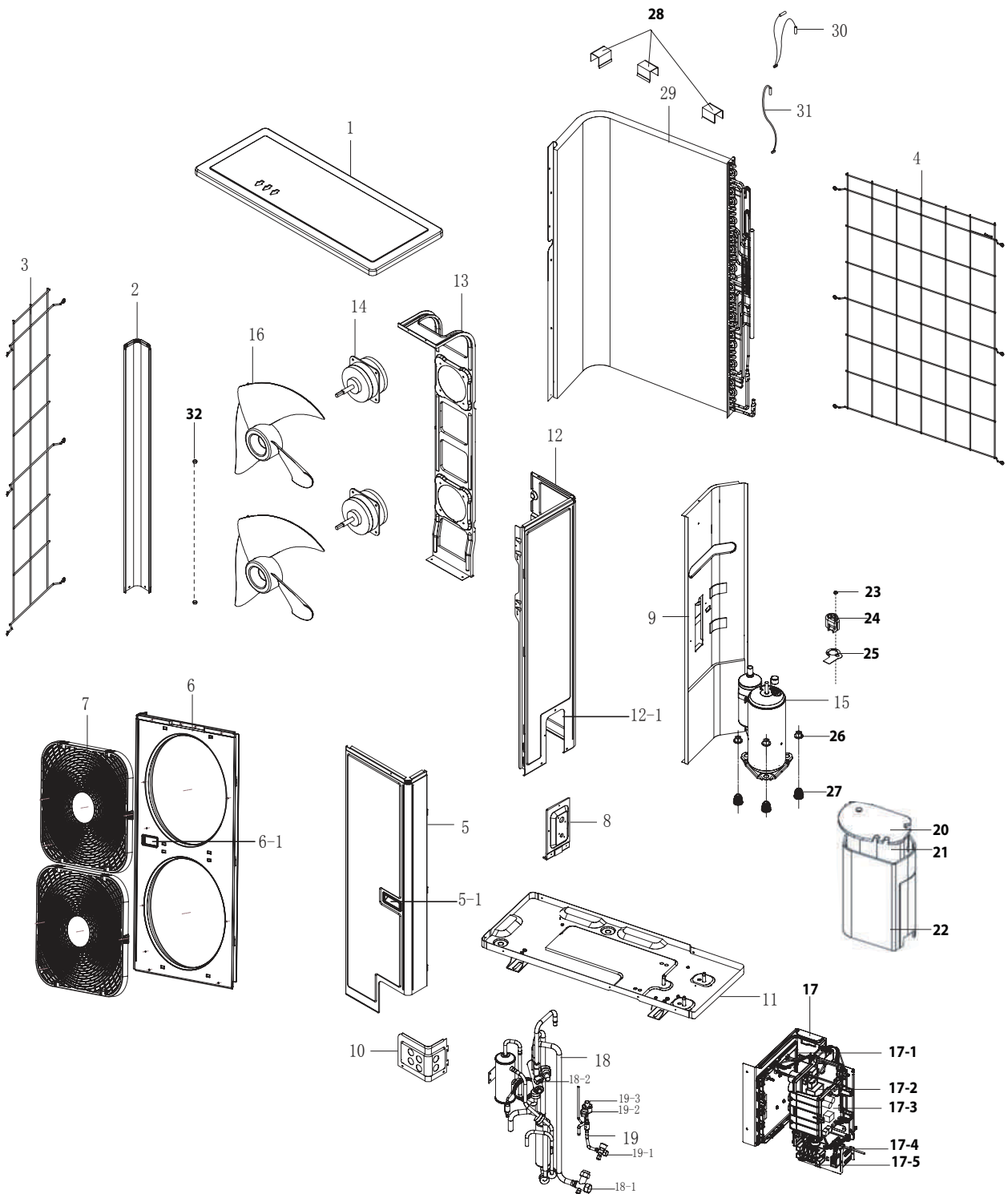

## ■ Parts List

No	Parts Code	Parts Description	Spec.	Q'ty	SA/SNA
				AQN36VF UAGM/CV	
1	DB90-07222A	ASSY COVER TOP	UH140GZMC,SSEC	1	SA
2	DB90-07103A	ASSY CABI BACK-LF	UP110(&140)EAV,EHS PJT	1	SA
3	DB63-03316A	GUARD COND-B	MSWR,SSEC	1	SA
4	DB63-03315A	GUARD COND-A	MSWR,OD3.5,SSEC	1	SA
5	DB90-07219B	ASSY CABI FRONT RH	SSEC	1	SA
5-1	DB64-01231C	HANDLE	ABS	1	SNA
6	DB90-07220D	ASSY CABI FRONT-LF	SSEC	1	SA
6-1	DB64-01231C	HANDLE	ABS	1	SNA
7	DB63-02226D	GUARD FAN	GUARD FAN,PP+GF,SSEC	2	SA
8	DB90-07110A	ASSY BRACKET-VALVE	SSEC	1	SA
9	DB94-03569A	ASSY PARTITION	RC140SHXEC,SSEC,S50-2	1	SA
10	DB90-07117C	BRACKET-WIRE PAINT	SSEC	1	SA
11	DB90-07243E	ASSY-CABI BASE PART	SAMSUNG ROTARY 55F,S50-2	1	SA
12	DB90-07215G	ASSY CABI BACK-RH	RC140SHXEC,S50-2	1	SA
12-1	DB64-01231C	HANDLE	ABS	1	SNA
13	DB94-01767A	ASSY BRACKET MOTOR	UH140EAV,SGCC-M,1.6,SSEC	1	SA
13-1	DB90-02583B	ASSY-MOTOR BRACKET SUB	AP55Q0AXIMG,SSEC	1	SA
14	DB31-00512F	MOTOR FAN	FMBC531SSK,124[W],1050RPM,DC310V,M AX IC 85°C,1500mm , Class E	2	SA
15	UG5T360FUCEKSS	COMPRESSOR	RCP,55,F,R410A	1	SA
16	DB67-00861A	FAN-PROPELLER	WW3,AS+GF20%,460,3,T3.5,SSEC,	2	SA
17	DB93-09771D	ASSY CONTROL OUT	HP,INV,AQV36UGAKCV	1	SNA
17-1	DB93-11112D	ASSY PCB MAIN-INVERTER	RC100DHXEA, RC100PHXEA, RC125PHXEA,Inverter Platform	1	SA
17-2	DB93-12326C	ASSY PCB MAIN-OUT	RAC OUT DOOR,Inverter Platform #4, #5, #6 MAIN,Y,SMPS,TOP264VG,5Vdc, 12Vdc	1	SA
17-3	DB93-11110A	ASSY PCB SUB-EMI	GLOBAL-4WAY OUTDOOR,Inverter Platform #4, #5 1Phase EMI,N	1	SA
17-4	DB65-00061H	TERMINAL BLOCK	FORTE-PJT,PBT,2-TAB,2- SCREW,Max2.5MM^2,36.4*24.2MM^2,BLK,3	1	SNA
17-5	DB65-00296A	TERMINAL BLOCK	RC140DHXEA,PC,4-SCREW 4-	1	SNA
18	DB96-17910A	ASSY-4WAY VALVE	S50-2,SSEC	1	SA
18-1	DB62-02342A	VALVE SERVICE	G3-P/J,-,5/8",-,-,-	1	SA
18-2	DB33-00002G	SOLENOID-VALVE ASSY	-,UH105/140GAV,220~240V,50/60Hz,450,-,-	1	SNA
19	DB96-09949A	ASSY-EEV VALVE	HP,INV,-,-,E,-,-,-,-,-,WW,SSEC	1	SA
19-1	DB62-02283A	VALVE SERVICE	G2-P/J,-,1/4",-,-,-	1	SNA
19-2	DB62-04067A	VALVE-EXPANSION COIL	QA(Q)12-SXK-04-	1	SA
19-3	DB62-04267A	VALVE-EXPANSION BODY	DPF(Q)1.8C-17-RK(E),-	1	SA
20	DB63-03262A	FELT-COMP UPPER OUT	Maldives 1,FELT+PVC,GRAY,SSEC	1	SNA
21	DB72-00630F	INSULATION-SOUND	FELT,W330,L710,GRAY,RAC,SSEC	1	SNA
22	DB63-03263A	FELT-COMP OUTSIDE	Maldives 1,FELT+PVC,GRAY,SSEC	1	SNA
23	6021-001142	NUT-HEXAGON FLANGE	-,M5,ZPC(YEL),SWCH10A,SERRATION	1	SNA
24	DB63-02280A	COVER TERMINAL	55F TBR,CEXP-0023C,BLACK	1	SNA
25	DB63-02281B	GASKET	55F TBR,SIR,T0.8,60-70	1	SNA
26	DB60-30028A	NUT-FLANGE	HWH,M8,ZPC(WHT),SWRCH18A,P1.25/Wa sher Type(WP)	3	SNA
27	DB63-00801B	GROMMET ISOLATOR	NR,L32.5,ID11.5,OD40,BLACK,SSEC	3	SNA
28	DB70-00163A	PLATE-COND	MH18VA1,SGCC-M,1.0T,SILVER,MULTI-	2	SNA
29	DB96-09416A	ASSY COND UNIT-BENDING	UH105EAV,SSEC	1	SA
30	DB93-13198D	ASSY CONNECTOR WIRE-COMP	MAN U,INV	1	SA
31	DB95-05071A	ASSY THERMISTOR OUT	36K KCV,SSEC	1	SA
32	DB60-30020A	NUT-HEXAGON FLANGE	M6,Zn-Ni,MSWR3,CLOCKWISE	2	SA

## 5-3 ASSY-CONTROL IN

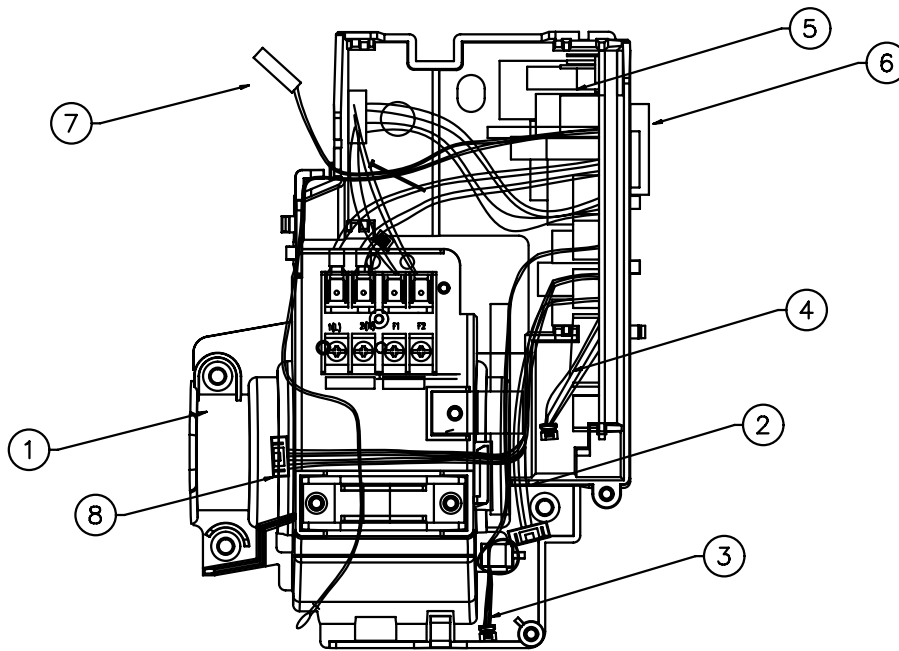

### PartList

ASSY CONTROL IN CODE		DB93-12914C		
适用型号		MALDIVE HIGH 9~12K H/P MPI无 非恶劣 AQN09VFUAGM/CV AQN12VFUAGM/CV		
NO	NAME	SPEC	CODE-NO	QTY
1	ASSY CASE CONTROL IN	MALDIVE	DB90-06932A	1
2	MAIN PBA TO DISPLAY	10 PIN TO 9 PIN	DB93-10918H	1
3	ASSY C/W LOUVER	5 PIN, 250mm, WHITE	DB93-04688B	0
4	MPI WIRE	4 PIN, 100mm	DB93-04695B	0
5	ASSY PCB MAIN	MALDIVE1 HIGH EEV	DB93-12827B	1
6	LABEL BAR CODE	45, 15, E-PASS	DB68-02809A	1
7	ASS'Y THERMISTOR	3*, BLK, SMH200, WHT	DB95-04570B	1
8	ASSY CONNECTOR WIRE	FJM WIRE	DB93-10943H	1
9	ASSY CONNECTOR WIRE	485 CONNECTOR WIRE	DB93-10943P	1

## 5-3 ASSY-CONTROL IN

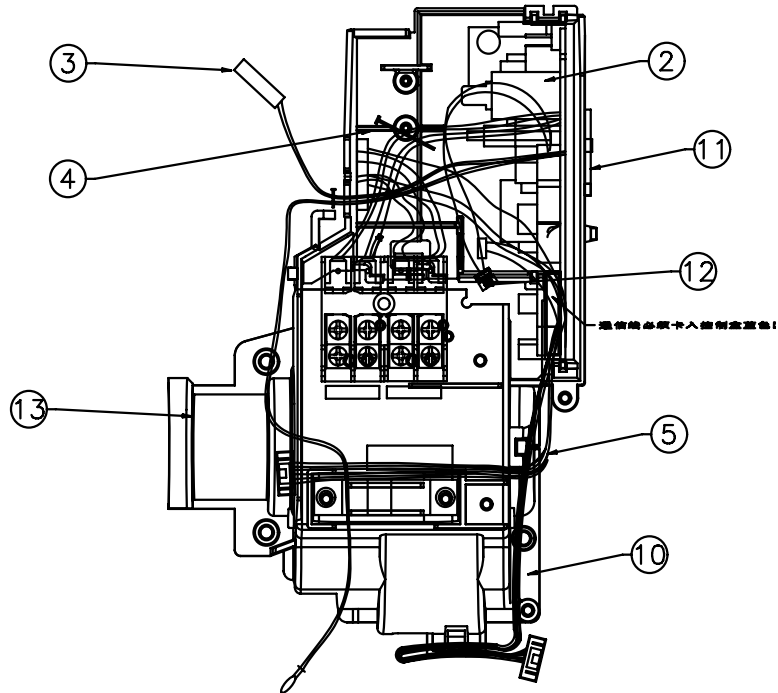

### PartList

	ASSY CONTROL IN CODE		DB93-12915H		DB93-12915J	
	适用型号		MAX KCV向 18K MPI无 H/P 恶劣 AQN18VFUAGM/CV		MAX KCV向 24K MPI无 H/P 恶劣 AQN24VFUAGM/CV	
NO	NAME	SPEC	CODE-NO	QTY	CODE-NO	QTY
1	ASSY HUMIDITY SENSOR	3PIN	DB95-01703A	0	DB95-01703A	0
2	ASSY PCB MAIN-IN	MALDIVE3	DB93-12828C	1	DB93-12828C	1
3	ASSY THERMISTOR IN	3x, BLK, SMH200, WHT	DB95-04570B	1	DB95-04570B	1
4	CABLE TIE	NYLON66	DB65-10088D	0	DB65-10088D	0
5	ASSY CONNECTOR WIRE	10 PIN TO 9 PIN	DB93-10918H	1	DB93-10918H	1
6	ASSY CONNECTOR WIRE	2 PIN	DB93-10917A	0	DB93-10917A	0
7	ASSY CONNECTOR WIRE	5 PIN, 250mm, WHITE	DB93-04688B	0	DB93-04688B	0
8	ASSY CONNECTOR WIRE	5 PIN, BLK	DB93-10918E	0	DB93-10918E	0
9	ASSY CONNECTOR WIRE	5 PIN, RED	DB93-10918F	0	DB93-10918F	0
10	ASSY CONNECTOR WIRE	10PIN	DB93-10943H	1	DB93-10943H	1
11	LABEL BAR CODE	LABEL	DB68-02809A	1	DB68-02809A	1
12	ASSY CONNECTOR WIRE	4 PIN, 100mm	DB93-04695B	0	DB93-04695B	0
13	ASSY CASE CONTROL IN	MALDIVE	DB90-06933A	1	DB90-06933C	1
14	485 COMM WIRE CHANGE	2 PIN	DB93-10943P	1	DB93-10943P	1

## 5-3 ASSY-CONTROL IN

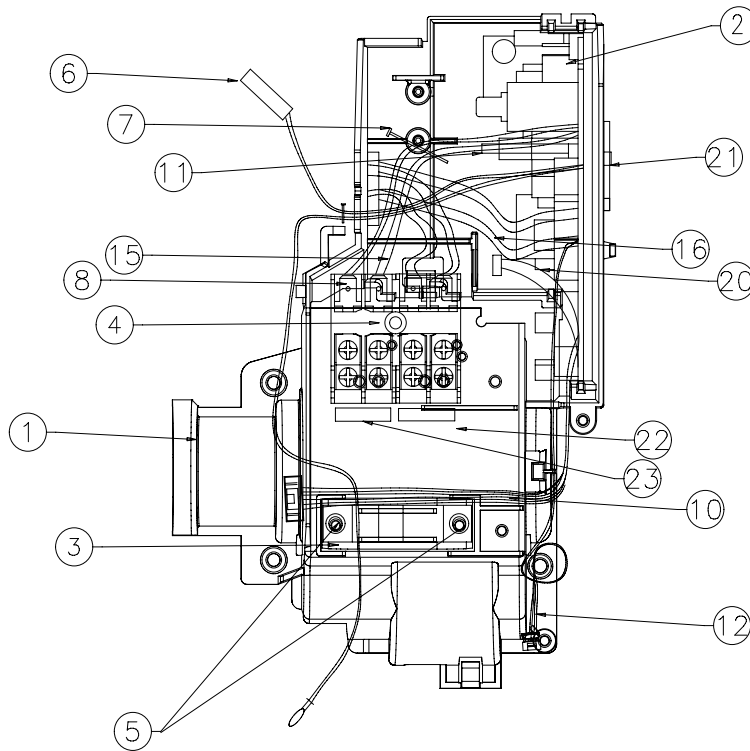

### PartList

ASSY CONTROL IN CODE			DB93-09711A	
Model			MAX KCV向 AQN36VFUAGM/CV H/P	
NO	NAME	SPEC	CODE-NO	QTY
1	CASE CONTROL IN	MALDIVE	DB61-04576A	1
2	ASS'Y PCB MAIN	MALDIVE3	DB93-10956A	1
3	HOLDER WIRE CLAMP	ABS,BLK,V'	DB61-01097A	1
4	SCREW	PH M3*L25	DB91-00309A	1
5	SCREW	TH M4*L10	DB97-02418A	2
6	ASS'Y THERMISTOR	3*,BLK,SMH200,WHT	DB95-04570B	1
7	CABLE TIE	NYLON66	DB65-10088D	1
8	TERMINAL BLOCK	[1(L),2(N),F1,F2]	DB65-00176C	1
9	T.P I LOCK	(F1,F2)	DB65-00297A	0
10	MAIN PBA TO DISPLAY	10 PIN TO 9 PIN	DB93-10918H	1
11	MAIN PBA TO TERMINAL	2 PIN	DB93-10917A	0
12	ASSY C/W LOUVER	5 PIN,250mm,WHITE	DB93-04688B	1
13	ASSY C/W LOUVER	5 PIN,BLK	DB93-10918E	0
14	ASSY C/W LOUVER	5 PIN,RED	DB93-10918F	0
15	POWER IN WIRE	2 PIN	DB93-10942A	1
16	COMM WIRE	2 PIN	DB95-04339C	1
17	MPI WIRE	4 PIN,100mm	DB93-04695B	0
18	PLATE CONTROL IN	JUNGFRAU	DB61-04724A	0
19	ASS'Y HUMIDITY	3PIN	DB95-01703A	0
20	FJM WIRE	10PIN	DB93-10943H	1
21	LABEL	LABEL	DB68-02809A	1
22	COMMUNICATION LABEL	LABEL	DB98-33292A	1
23	POWER LABEL	LABEL	DB98-33293A	1



# 5-4 Ass'y Control Out -AQX09/12/18VFUAGM/CV

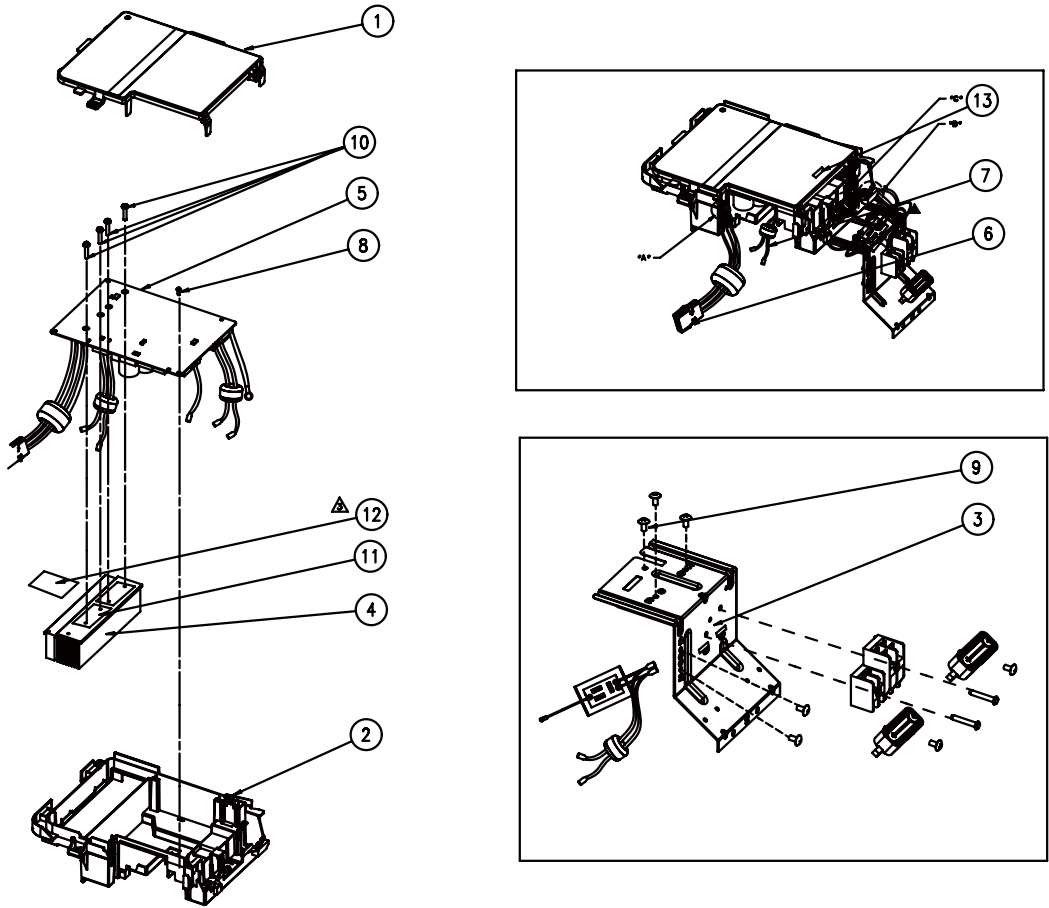

ASSY CONTROL OUT CODE				DB93-10960K	DB93-10960L
通用型号				AQX09VFUAGM/CV AQX12VFUAGM/CV	AQX18VFUAGM/CV
NO	CODE-NO	NAME	SPEC	QTY	QTY
1	DB61-04659A	CASE CONTROL-COVER	SI (RAC)	1	1
	DB61-04885A	CASE CONTROL-COVER	SI (FAC)	0	0
2	DB61-04658A	CASE CONTROL-BASE	SI/OI (RAC)	1	1
	DB61-04877A	CASE CONTROL-BASE	SI (FAC)	0	0
3	DB90-06308A	ASSY CASE CONTROL OUT	SI	0	0
	DB90-06308B	ASSY CASE CONTROL OUT	SI	0	0
	DB90-06308C	ASSY CASE CONTROL OUT	SI	0	0
	DB90-06308D	ASSY CASE CONTROL OUT	SI ,FAC	0	0
	DB90-06308E	ASSY CASE CONTROL OUT	SI ,KFR-50W/BPPE	0	0
	DB90-06308F	ASSY CASE CONTROL OUT	SI ,KFR-50W/BPPE	1	1
	DB90-06308G	ASSY CASE CONTROL OUT	SI	0	0
4	DB62-09724A	HEAT SINK	12K	1	0
	DB62-09725A	HEAT SINK	18K	0	1
5	DB62-10652A	HEAT SINK	18K	0	0
	DB93-10952A	ASSY PCB MAIN	SI (11R RAC)	0	0
	DB93-10952C	ASSY PCB MAIN	SI (11R FAC)	0	0
	DB93-13183A	ASSY PCB MAIN	SI (12R RAC)	1	1
	DB93-13183C	ASSY PCB MAIN	SI (12R FAC)	0	0
6	DB93-09497C	WIRE-COMP	AWG16, RED, BLU, YEL	1	1
7	DB93-09493C	WIRE-REACTOR	AWG16, WHT	0	0
	DB93-09493E	WIRE-REACTOR	AWG16, WHT, FAC	0	0
	DB93-09493F	WIRE-REACTOR	AWG16, WHT	1	1
8	6002-000630	SCREW	PH +	1	1
9	6002-000527	SCREW	M4, L10	1	1
10	DB91-00933A	ASSY-SCREW MACHINE	M3, L12	4	4
11	0205-001303	THERAL GREASE	NYLON66	3g	3g
12	DB62-04956E	INSULATION-COND IN		1	1
13	DB68-02809A	BAR CODE LABEL		1	1

# 5-4 Ass'y Control Out -AQX24VFUAGM/CV

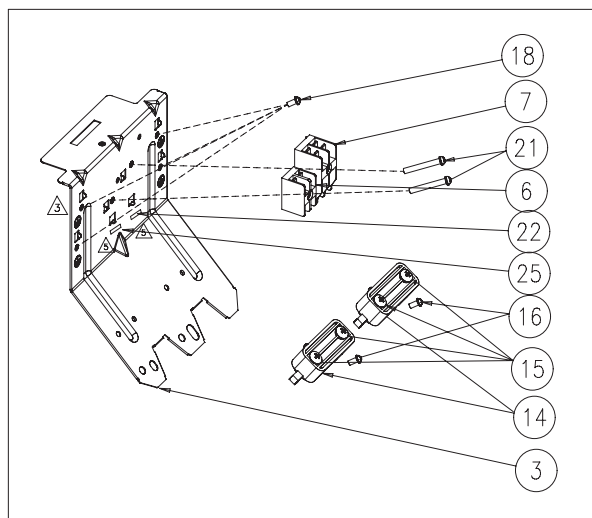
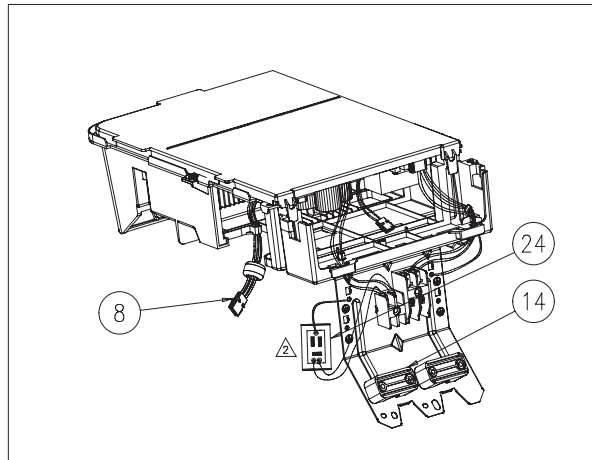
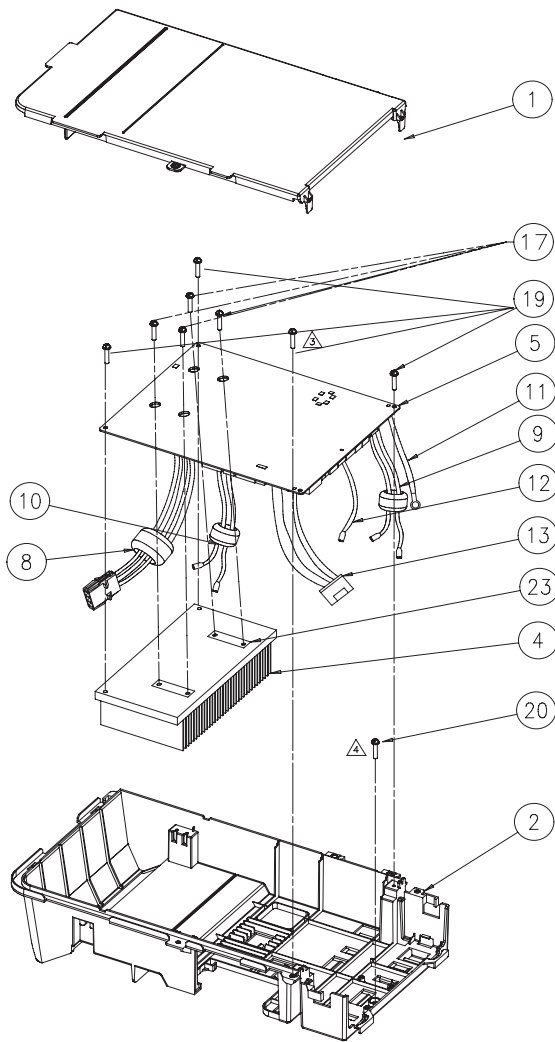

ASSY CONTROL OUT CODE				DB93-10961A
				BLDC FAN
Model				AQX24VFUAGM/CV
NO	CODE-NO	NAME	SPEC	QTY
1	DB61-04908A	CASE CONTROL -COVER	PF3	1
2	DB61-04910A	CASE CONTROL -BASE	PF3	1
3	DB61-05018A	PLATE-CONTROL OUT	PF3	1
4	DB62-09721A	HEAT SINK	PF3	0
	DB62-10653A	HEAT SINK	PF3	1
5	DB93-10939A	ASSY PCB MAIN	PF3	1
6	DB65-00297A	TERMINAL BLOCK	TERMINAL BLOCK-ASSY	1
7	DB65-00298B	TERMINAL BLOCK	TERMINAL BLOCK-ASSY	1
8	DB93-10988A	WIRE-COMP	AWG16,RED,BLU,YEL	1
9	DB93-09495B	WIRE-POWER	AWG16,BRN,SKYBLU	0
	DB93-09495H	WIRE-POWER	AWG16,BRN,SKYBLU	1
	DB93-10987A	WIRE-REACTOR	AWG16,WHT	1
11	DB93-09494B	WIRE-EARTH	AWG20,GRNYEL	1
12	DB93-11218A	WIRE-COMMUNICATION	AWG22,RED,BLU	1
13	DB93-10821A	WIRE-4 WAY	AWG18,BLU	1
14	DB61-00250A	HOLDER-WIRE CLAMP	HOLDER-WIRE CLAMP	2
15	6002-000214	SCREW	TH, +, -, 1, M4.0, L16, ZPC(BLK)	4
16	6001-001054	SCREW	M4, L25	2
17	DB91-00306A	ASSY-SCREW MACHINE	M3, L16	4
18	6009-001001	SCREW	M4, L8	4
19	6002-000630	SCREW	M3, L8	4
20	6002-000527	SCREW	M4, L10	0
21	6002-000555	SCREW	M4, L25	2
22	DB98-33293A	LABEL	POWER	1
23	DB98-24813A	THERMAL GREASE		2g
24	DB95-01712M	ASSY NOISE ABSORBER		1
25	DB98-33292A	LABEL	COMM	1

5-4 ASSY CONTROL OUT -AQX36VFUAGM/CV

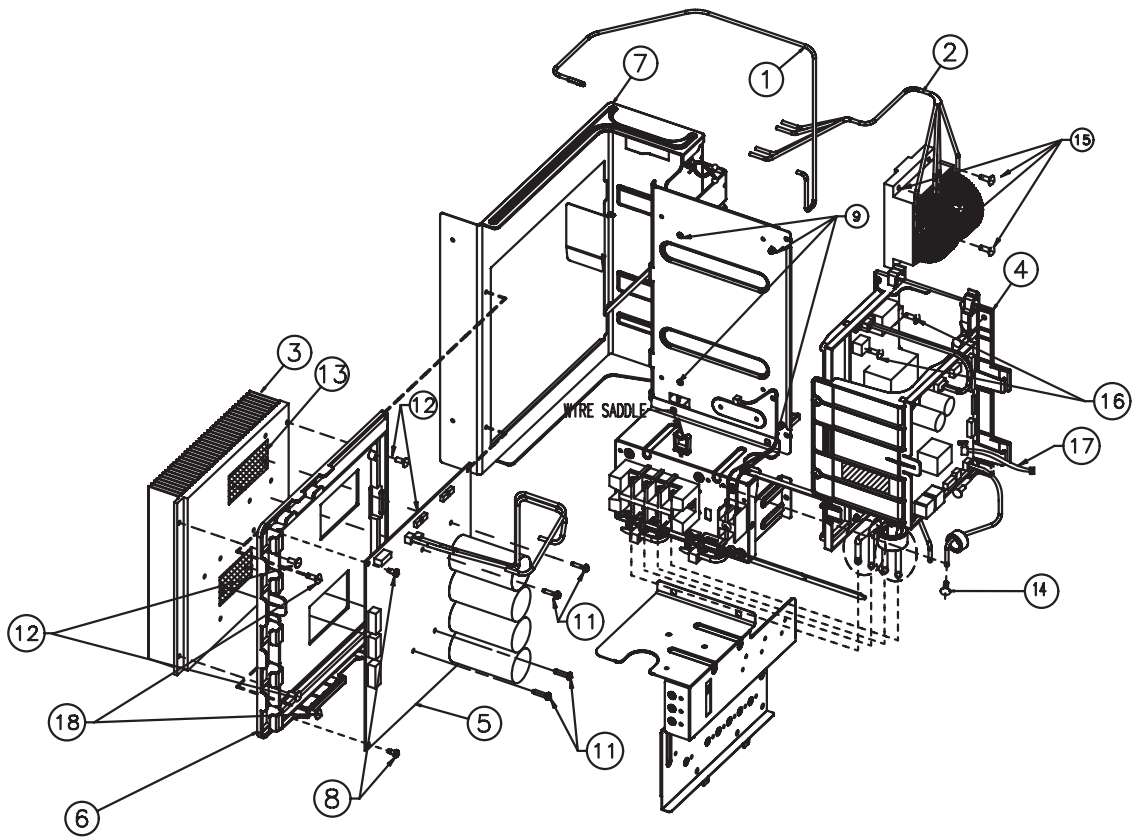
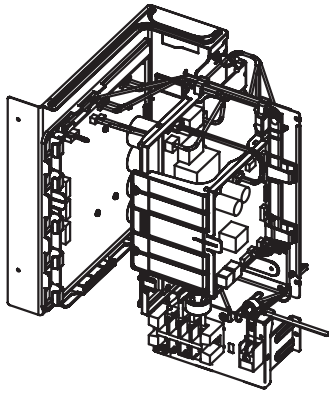

## Parts List(DB93-09771D)

NO	Parts Code	Parts Description	Spec.	QTY	SA/SNA
1	DB93-13119A	ASSY CONNECTOR WIRE-COMM(MAIN TO INV)	MAN U	1	SNA
2	DB59-00016A	AC REACTOR-1PHASE 30A	RC100PHXEA	1	SNA
3	DB62-10902A	HEAT SINK-1PHASE 30A	FJM,AL,10mm,187mm,200mm,COUNT-SINK,45mm	1	SNA
4	DB93-09902C	ASSY CONTROL OUT	HP,INV,CAC,LCI 4/5# CASE_PBA	1	SA
4-1	DB93-11110A	ASSY PCB SUB-EMI	ASSY, RC100SHXEC	1	SA
4-2	DB93-12326C	ASSY MAIN PCB	ASSY, RC100SHXEC	1	SA
5	DB93-11112D	ASSY PCB MAIN-INVERTER	ASSY, RC140SHXEC	1	SNA
6	DB61-05286A	CASE-INV	LCI ,OUTDOOR,ABS,VE-0860SE,SSEC,LCI	1	SNA
7	DB93-09793A	ASSY CONTROL OUT	HP,inv,CAC,LCI 4/5#,T_B PLATE	1	SA
8	6002-000536A	SCREW-TAPPING	TH,+,NO,2S,M4,L18,ZPC(WHT),SWRCH18A	2	SNA
9	6002-000231	SCREW-TAPPING	TH,+,NO,2S,M4,L12,ZPC(WHT),SWRCH18A	4	SNA
10	DB91-00306A	ASSY-SCREW MACHINE	BLDC INV. CONTROLLER,M3*16,WSP,PH,+,ZPC	2	SNA
11	DB91-00307A	ASSY-SCREW MACHINE	WW-INV,M4*16,WSP,PH,+,ZPC	2	SNA
12	6001-001054	SCREW-MACHINE	TH,+,NO,M4,L10,ZPC(WHT),SM20C,-	4	SNA
13	0205-001303	OIL-SILICON	SF9038A,OIL-SILICON,g	7	SNA
14	6009-001001	SCREW-SPECIAL	TH,+,WT,M4,L10,ZPC(WHT),SWRCH18A	1	SNA
15	6002-000216	SCREW-TAPPING	TH,+,NO,1,M4,L20,ZPC(WHT),SWRCH18A	4	SNA
16	6003-001150	SCREW-TAPTYPE	PH,+,WP,S,M5,L12,ZPC(BLK),SWRCH18A	2	SNA
17	DB93-12214A	ASSY CONNECTOR WIRE-POWER	LCI 4#,POWER,UL1007 AWG22,SKY-BLUE,BRN,130mm	0	SNA
18	6001-001054	SCREW-MACHINE	TH,+,NO,M4,L10,ZPC(WHT),SM20C,-	2	SNA

# 6. Wiring Diagram

## 6-1 Indoor Unit

AQN09/12VFUAGM/CV

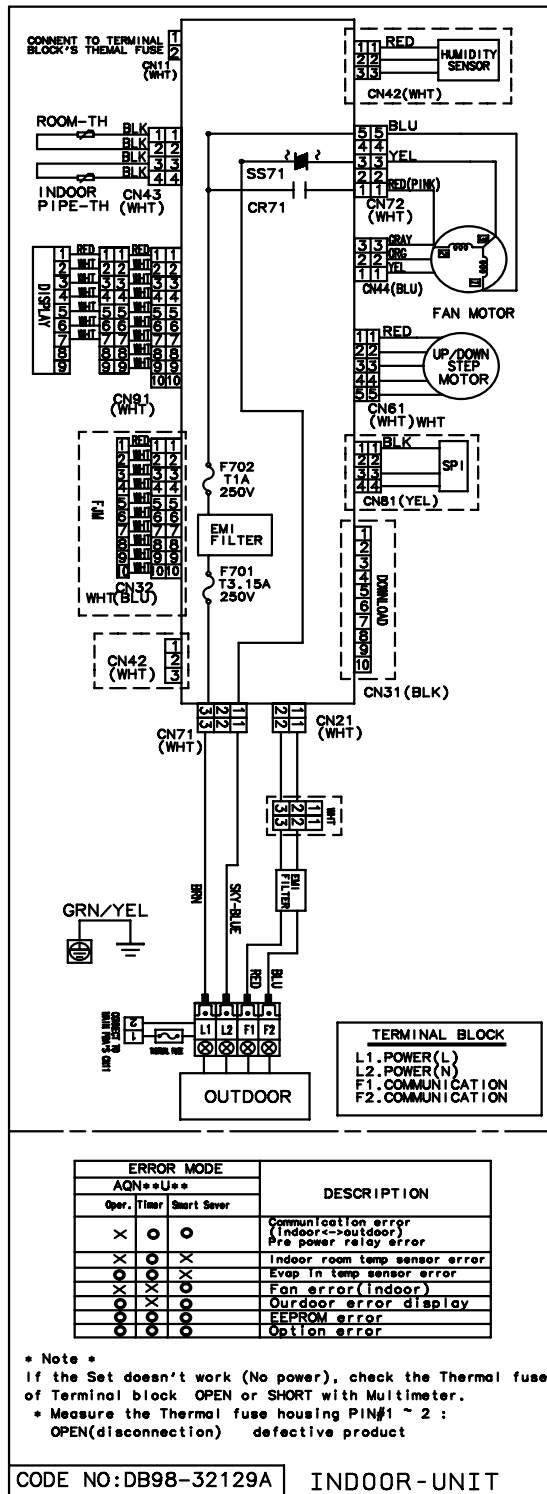

This Document can not be used without Samsung's authorization.

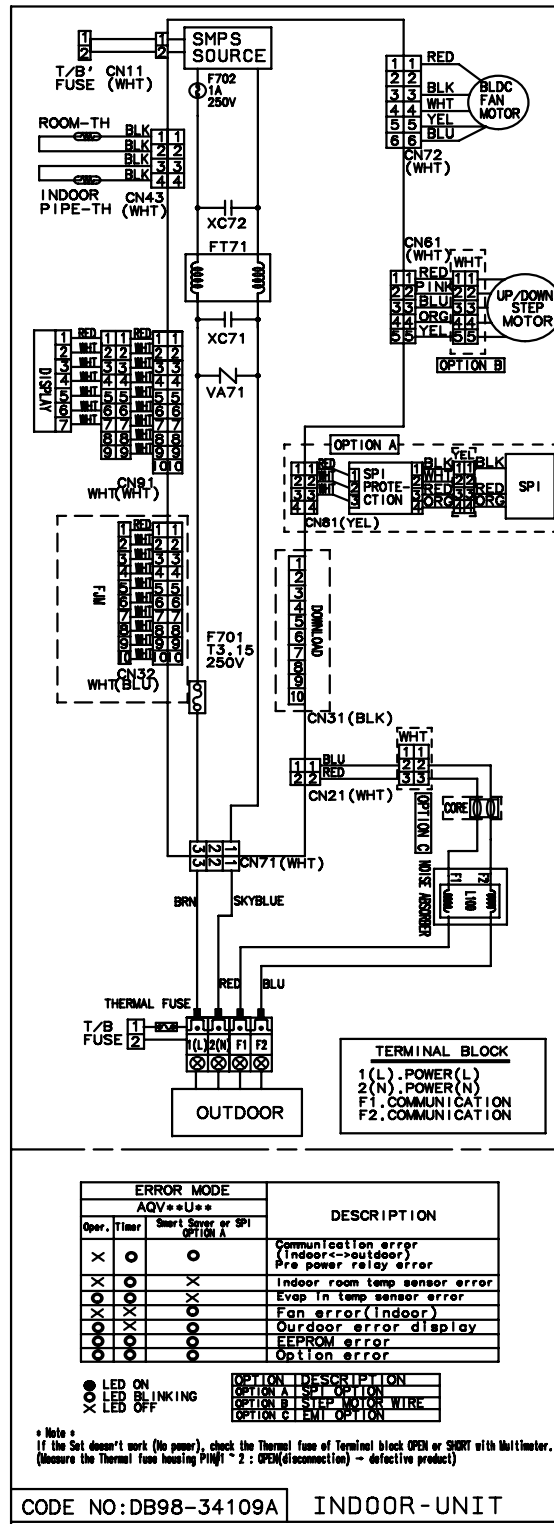

ERROR MODE			DESCRIPTION
AQV**U**			
Oper. Timer	Smart Sensor or SPI	OPTION A	
X	○	○	Communication error (Indoor->outdoor) Pre power relay error
X	○	X	Indoor room temp sensor error
○	○	X	Evap in temp sensor error
X	X	○	Fan error(Indoor)
○	X	○	Outdoor error display
○	○	○	EEPROM error
○	○	○	Option error

● LED ON  
 ○ LED BLINKING  
 X LED OFF

OPTION	DESCRIPTION
OPTION A	SPI OPTION
OPTION B	STEP MOTOR WIRE
OPTION C	TEMP OPTION

\* Note \*  
 If the Set doesn't work (No power), check the Thermal fuse of Terminal block OPEN or SHORT with Multimeter.  
 (Measure the Thermal fuse housing PIN#1 ~ 2 : OPEN(disconnection) - defective product)

CODE NO: DB98-34109A INDOOR-UNIT

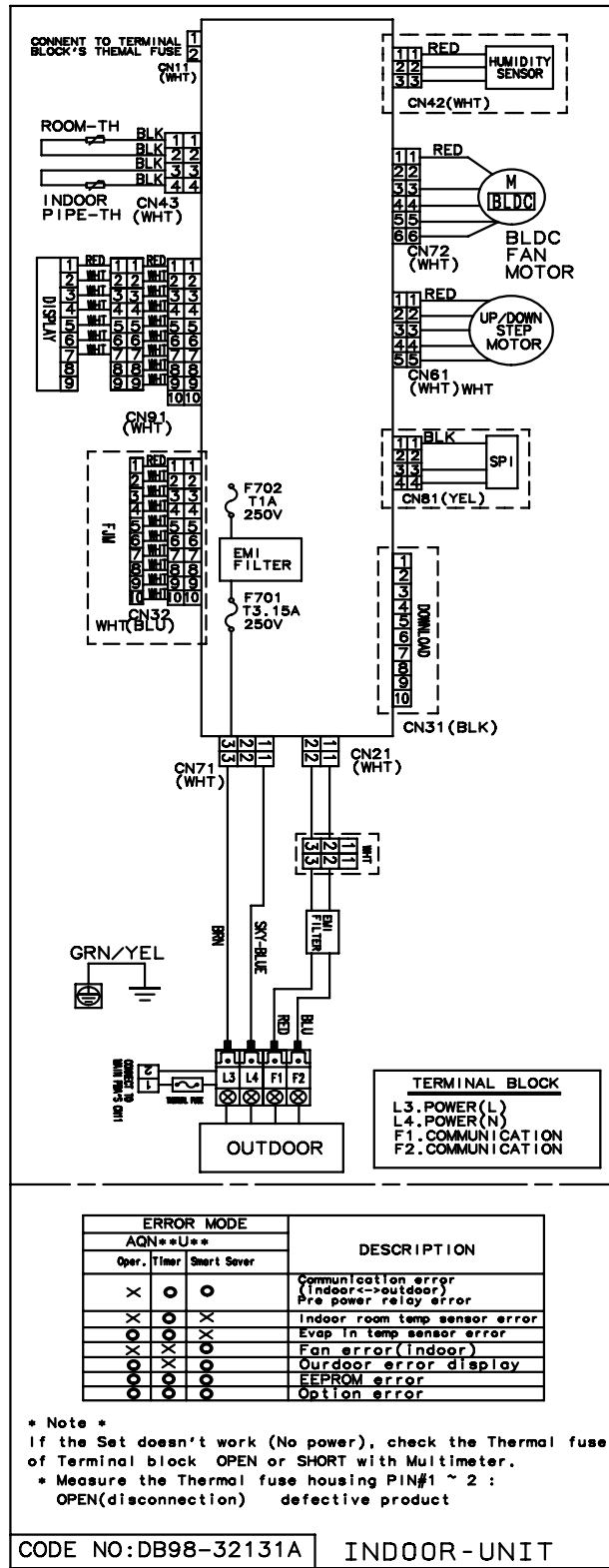

# 7-2 Outdoor Unit

AQX09/12/18VFUAGM/CV

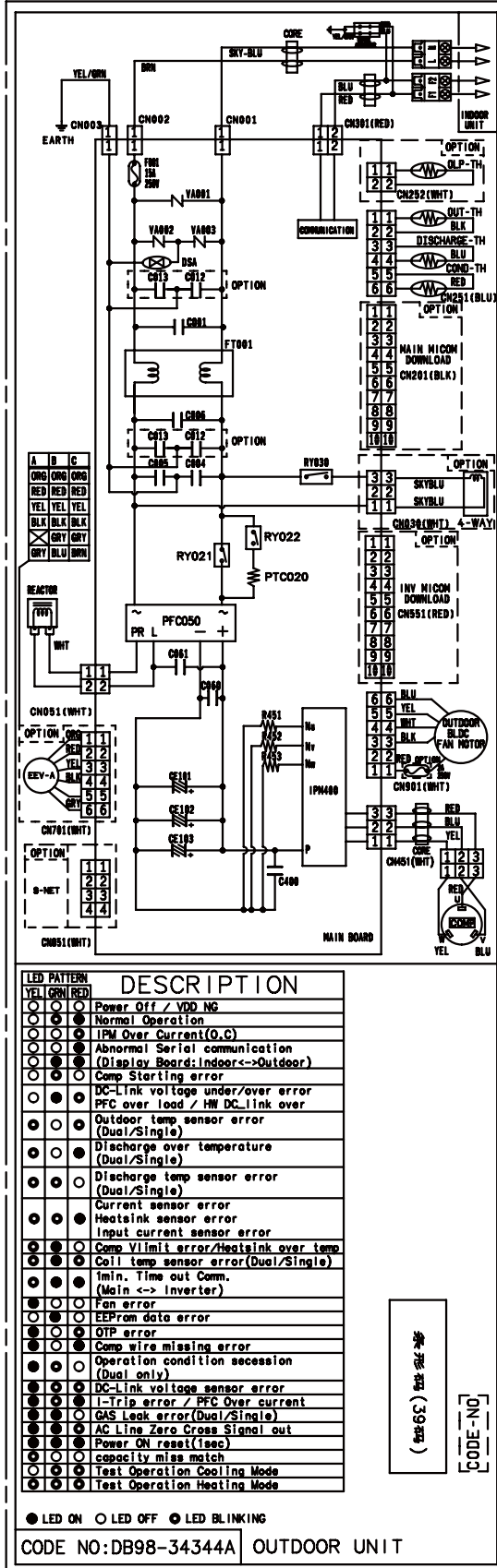

This Document can not be used without Samsung's authorization.



# 7-2 Outdoor Unit

AQX24VFUAGM/CV

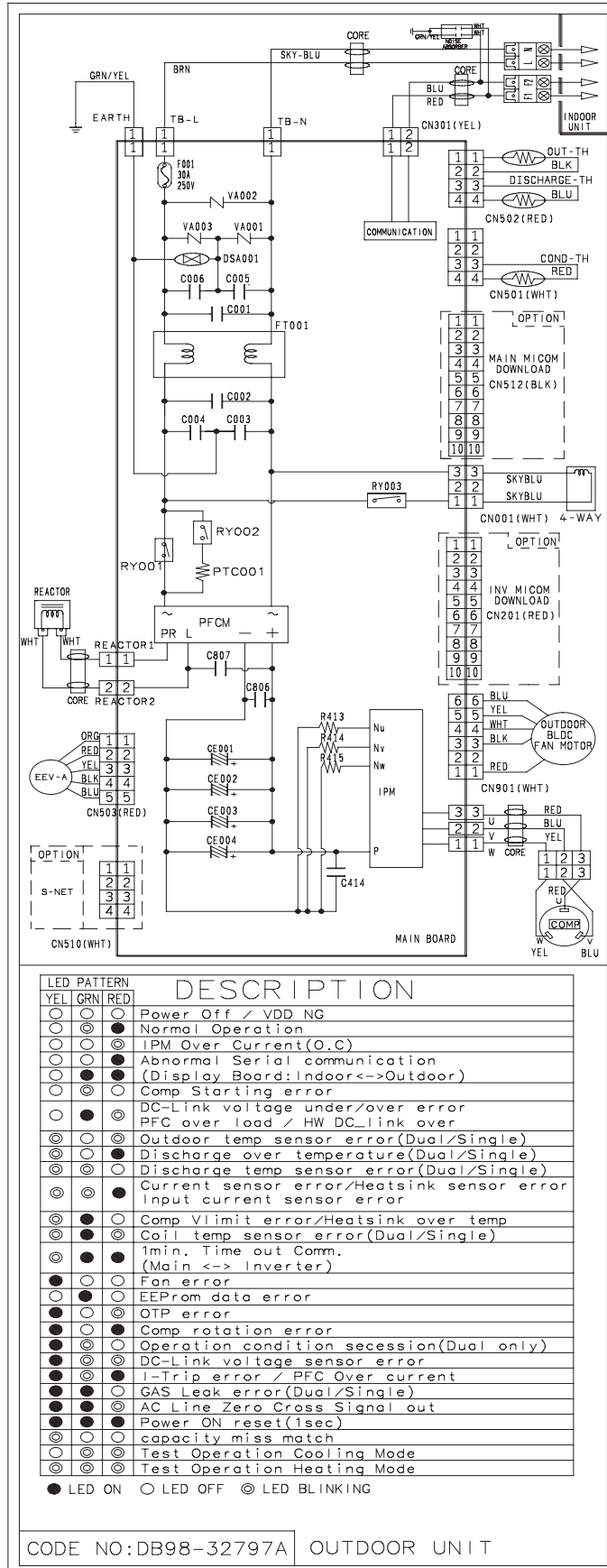

This Document can not be used without Samsung's authorization.

# 7-2 Outdoor Unit

AQX36VFUAGM/CV

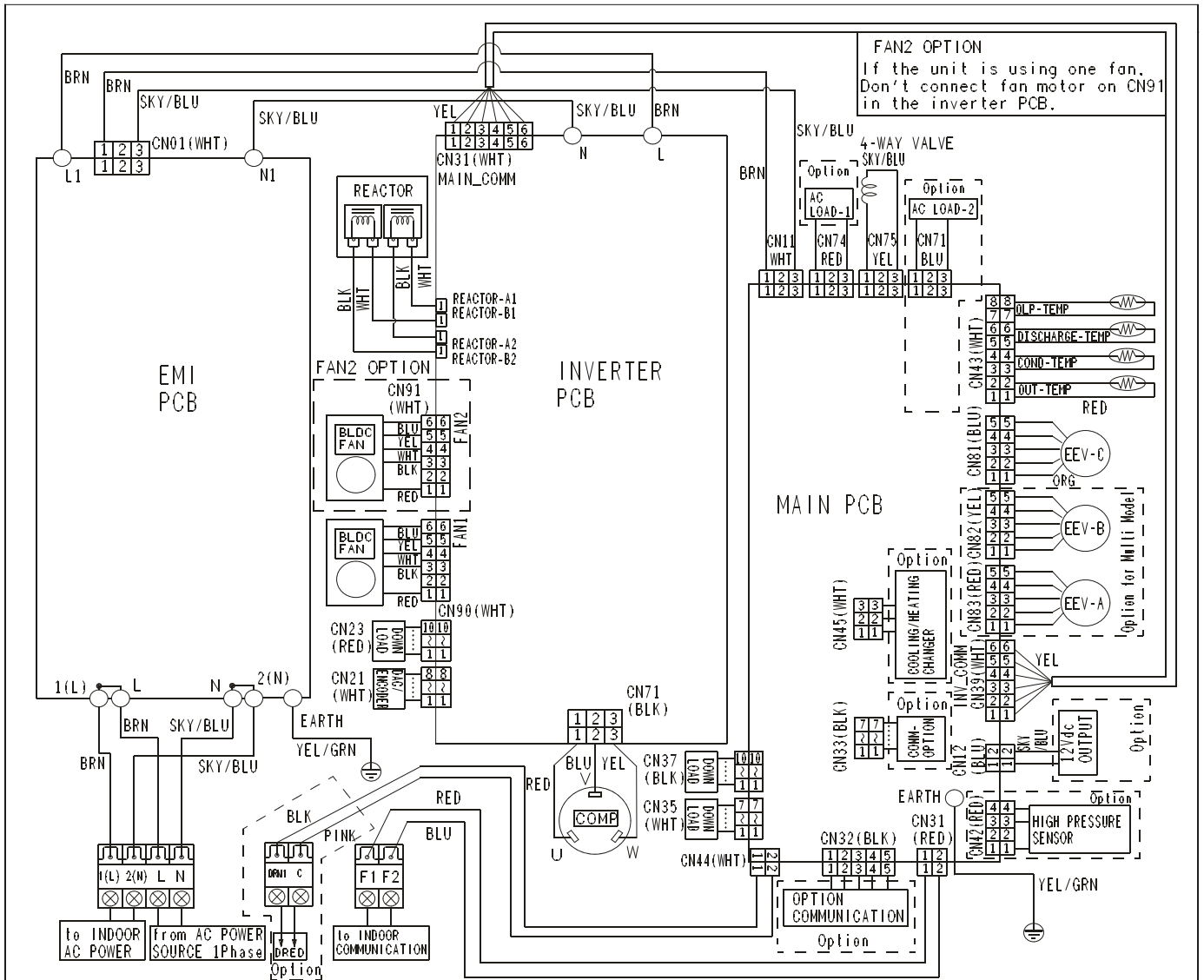

This Document can not be used without Samsung's authorization.



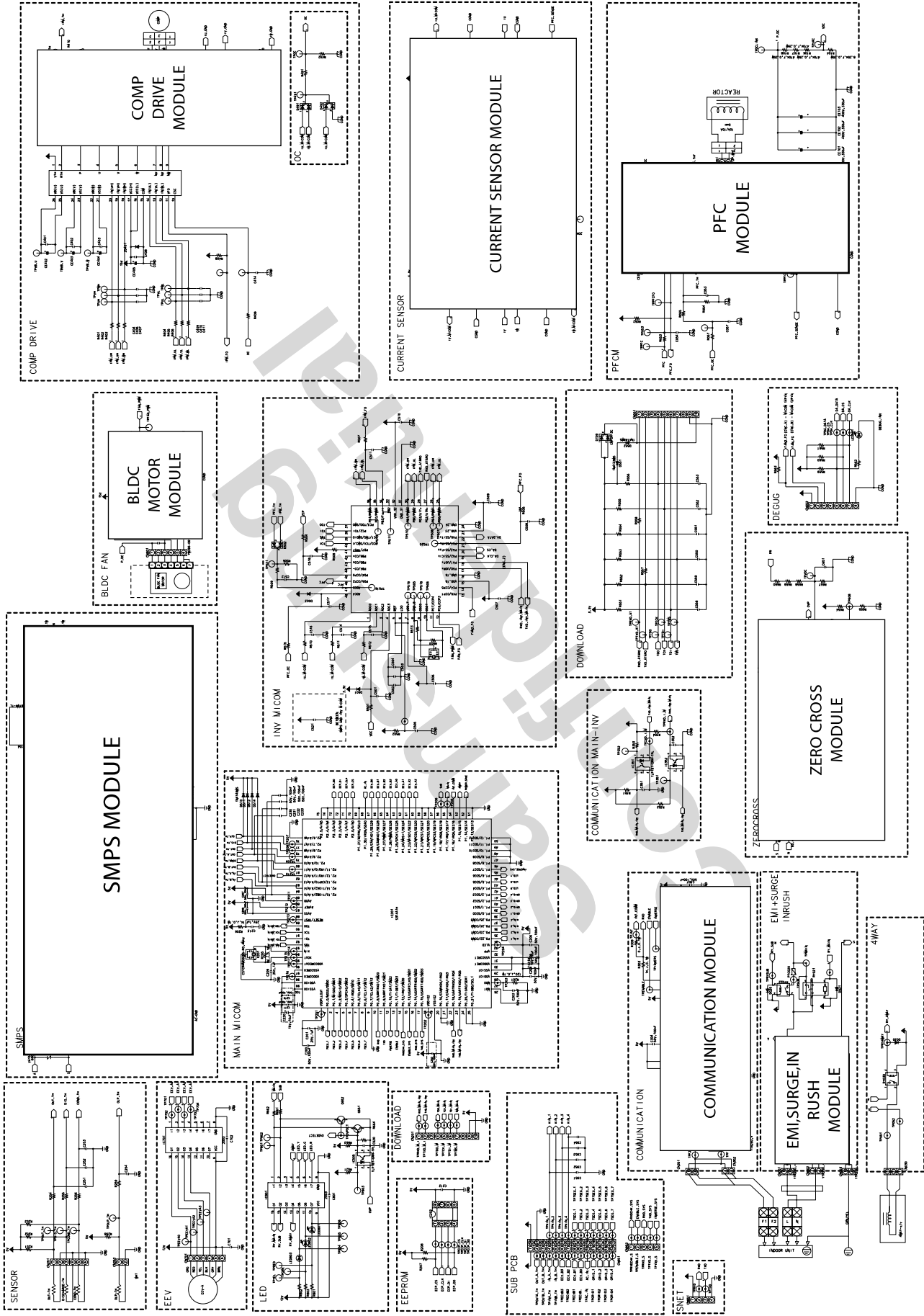

# 8-2 Outdoor Unit

AQX24VFUAGM/CV

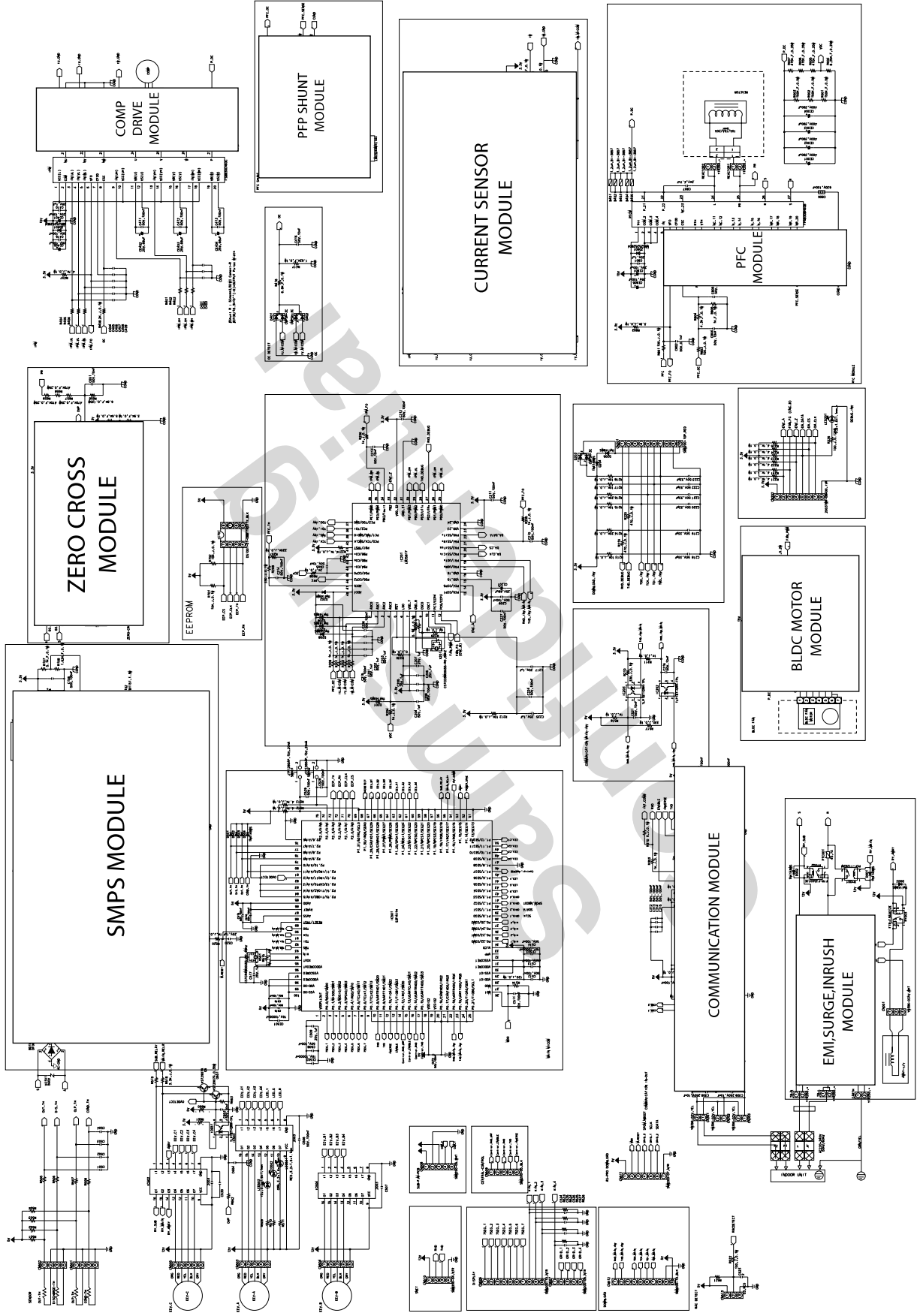

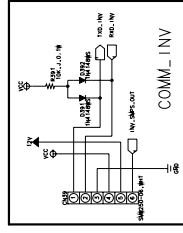
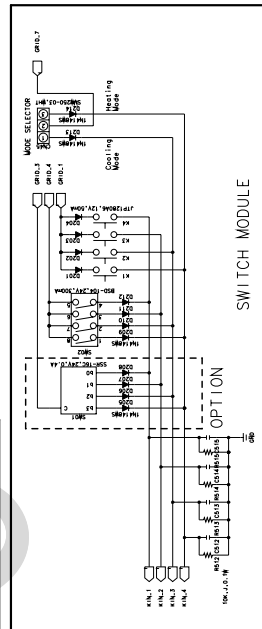
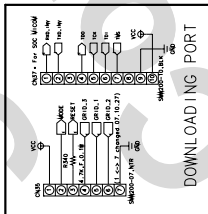
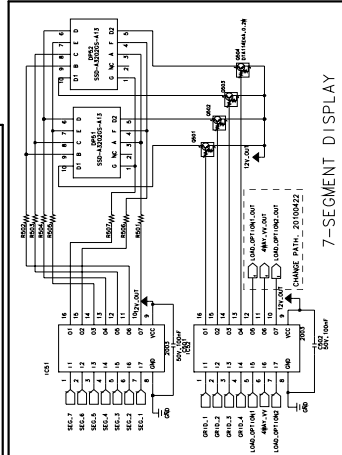
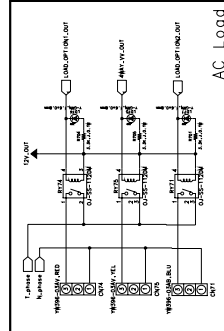
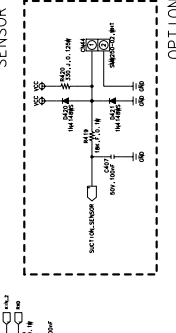
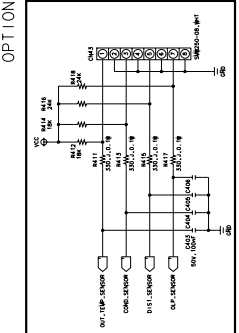
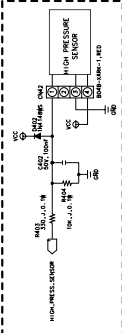
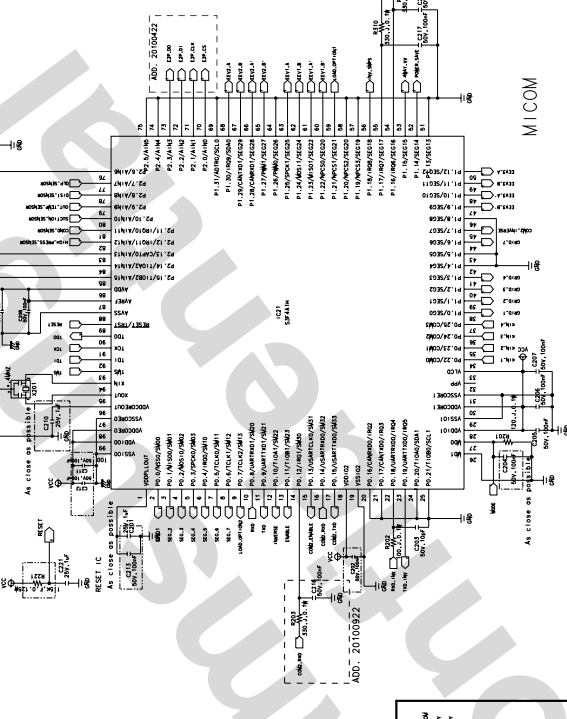
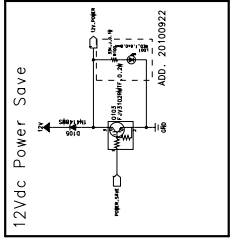
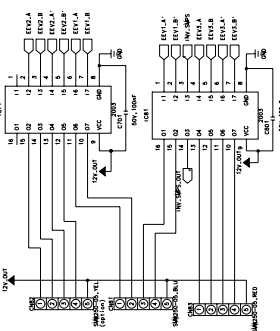
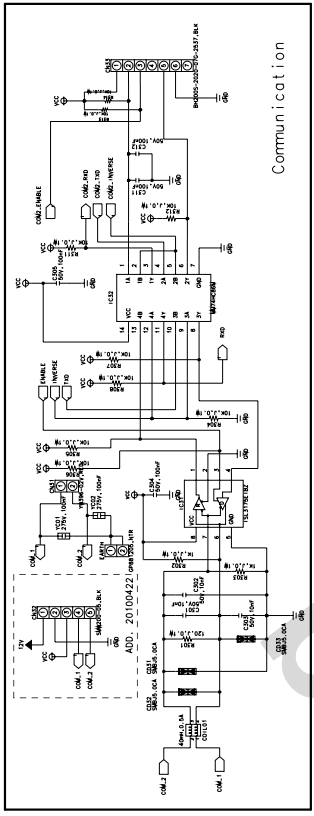
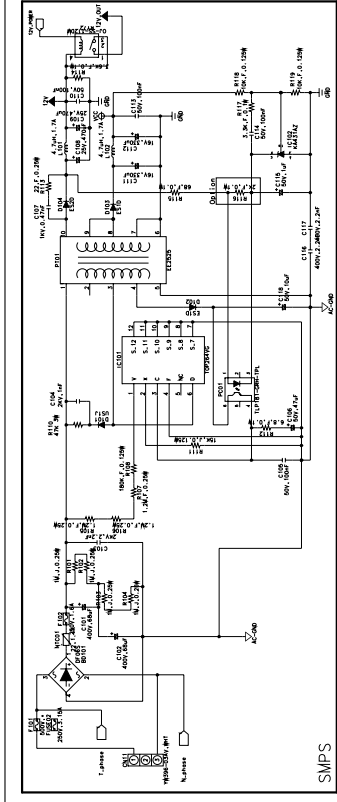

INVERTER PLATFORM #4, #5, #6 : MAIN  
F IM2, PAC

REV	DATE	CHG. BY	APPR. BY	DESIGN CHANGE	APPROVED BY	DATE
MODEL PCB MAIN P/N CODE (DB93-1) DB93-12326A P/N CODE (DB93-1) DB93-10081A REV. DATE 2011.02.15 CHECKED BY SAUNG-ELECTRONICS L.S.J.H. APPROVED BY 2011.02.15 CO., LTD.						

# 9 Refrigerating Cycle Diagram

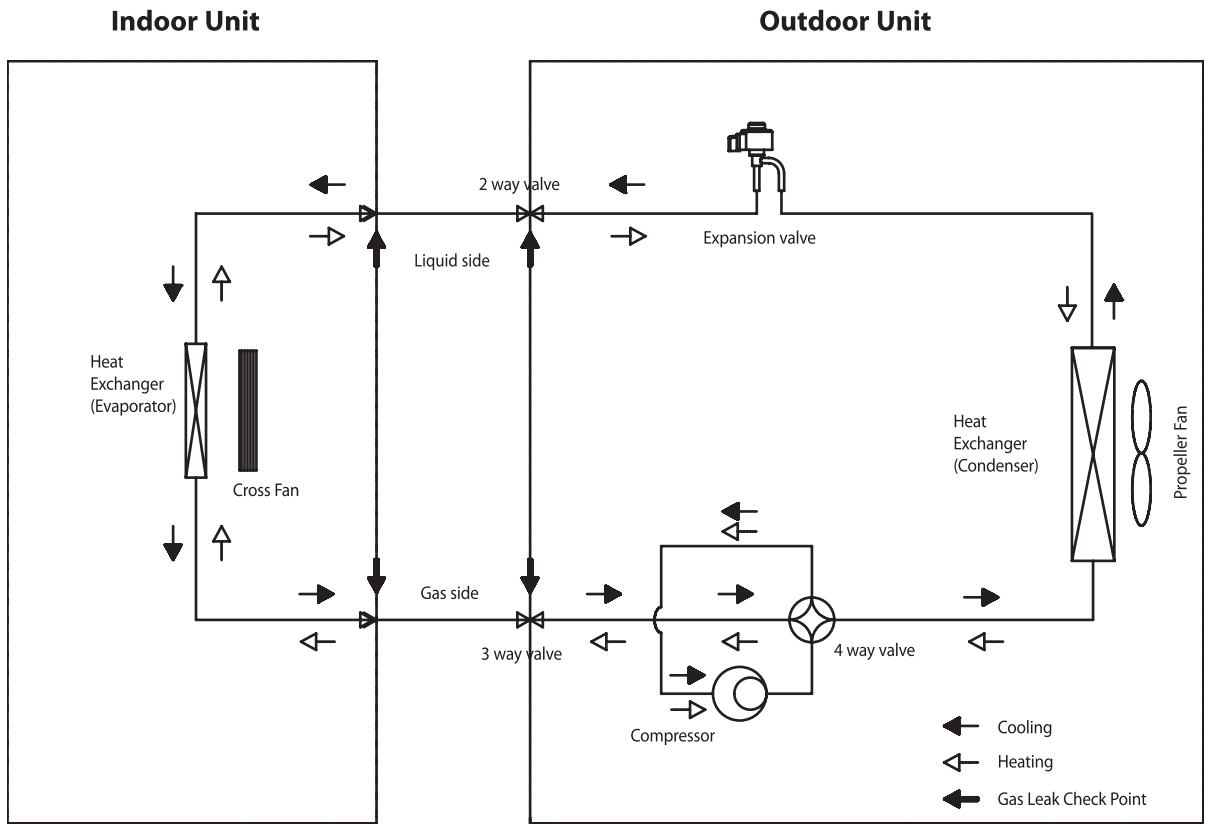

## 10-1 Indoor PCB

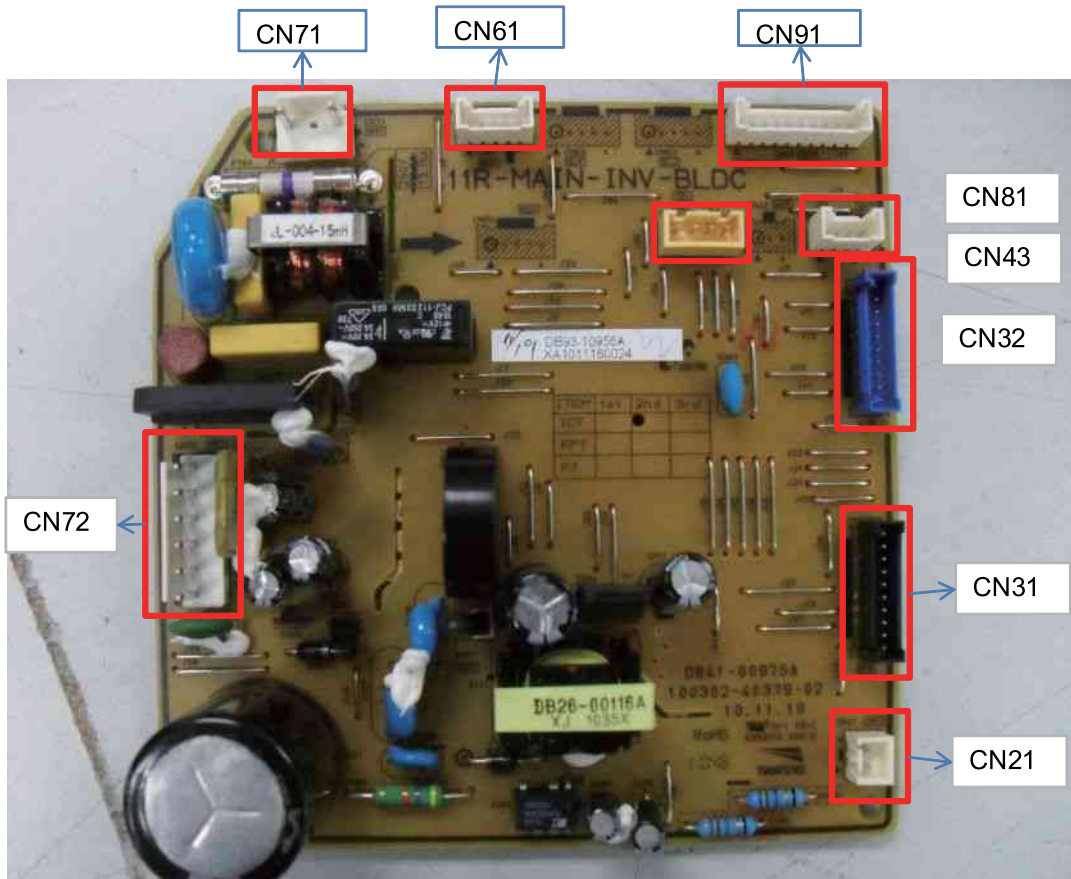

- 1.CN21-COMMUNICATION
- 2.CN31-DOWNLOAD
- 3.CN32-FJM
- 4.CN43-TEMPRATURE SENSOR
- 5.CN91-DISPLAY
- 6.CN81-MPI
- 7.CN61-STEP MOTOR
- 8.CN71-POWER IN
- 9.CN72-FAN MOTOR



## 10-2 Outdoor PCB

### AQX09/12/18VFUAGM/CV

 The red number connector is not used.

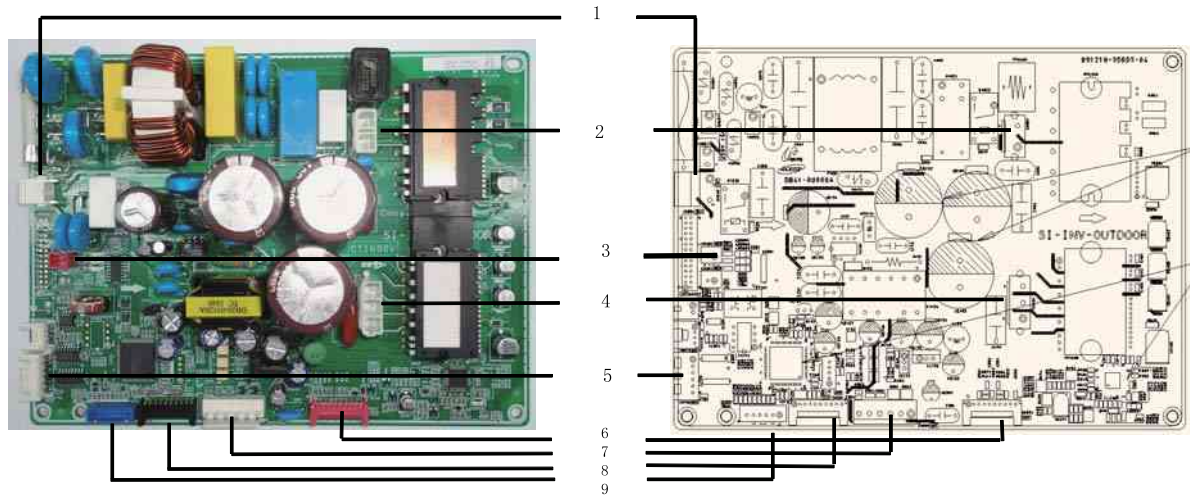

1. 4WAY	2. CN051-REACTOR	3. CN301-485 communication #1 F1 #2 F2	4. CN451-COMP #1 W phase #2 V phase #3 U phase	5. CN701-EEV #1 EEV signal #2 EEV signal #3 EEV signal #4 EEV signal #5, 6 12V
6. CN551-INV MICOM DOWNLOAD	7. CN901-BLDC FAN	8. CN201-MAIN MICOM DOWNLOAD	9. CN251-SENSOR #1 OUTDOOR TEMPERATURE #2 GND #3 DISCHARGE TEMPERATURE #4 GND #5 COND TEMPERATURE #6 GND	

### AQX24VFUAGM/CV

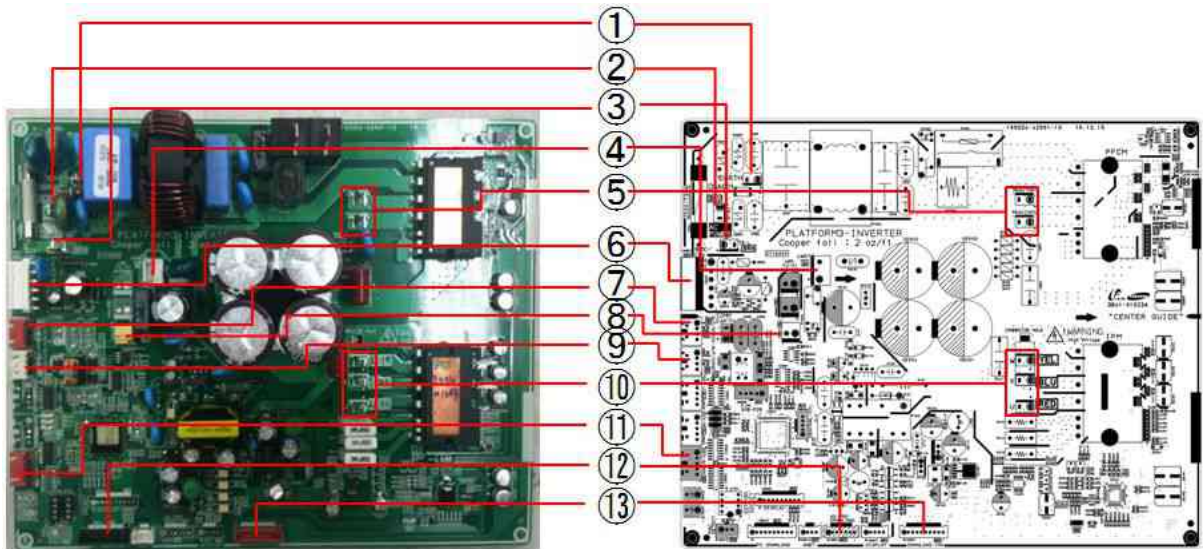

1	EARTH	EARTH	2	TB-N	POWER N
3	TB-L	POWE L	4	CN001	4-WAY
5	REACTOR1/2	REACTOR	6	CN901	FAN MOTOR
7	CN502	TEMP SENSOR - OUT/DIS	8	CN301	COMMUNICATION
9	CN501	TEMP SENSOR - COND	10	U/V/W	COMP
11	CN503	EEV	12	CN512	DOWNLOAD - MAIN
13	CN201	DOWNLOAD - INV			

## 10-2 Outdoor PCB

### AQX36VFUAGM/CV

 The red number connector is not used.

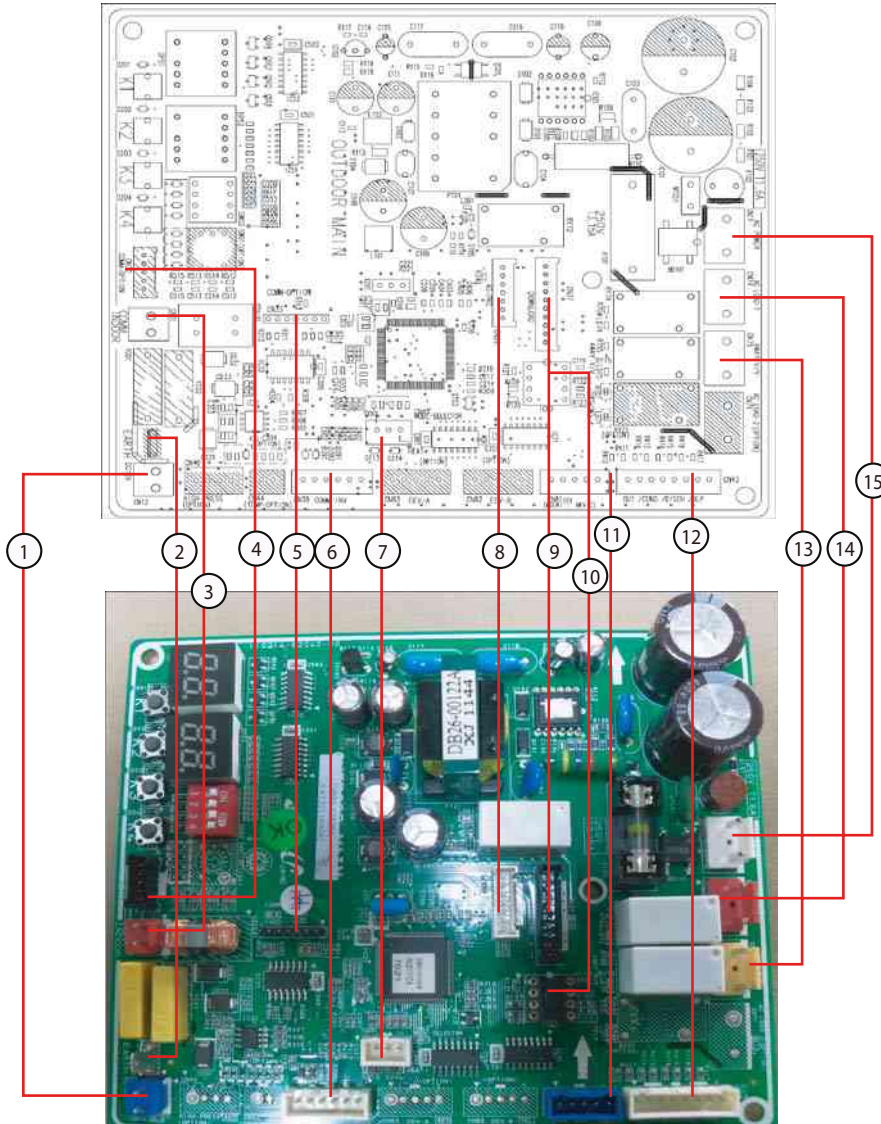

NO	LOCATION	NAME	SPEC
1	CN12	DC12V	YW396-02V(BLU)
2	EARTH	EARTH	TAB,MALE,N,0.5/4.75mm
3	CN31	COMM INDOOR	YW396-02(RE D)
4	CN32	COMM-OPTION	SMW200-05P(BLK)
5	CN33	COMM-OPTION	BH200S-2020-07G-2537(BLK)
6	CN39	COMM-INV	SMW250-06(WHT)
7	CN45	MODE-SELECTOR	SMW250-03(WHT)
8	CN35	AS-PRO	SMW200-07P(WHT)
9	CN37	DOWNLOAD	SMW200-10P(BLK)
10	IC83		DS1001-01-08BT1NST1X(BLK)
11	CN81	EEV	SMW250-05(BLU)
12	CN43	OUT/COND/DISCH/OLP	SMW250-08(WHT)
13	CN75	4WAY	YW396-03AV(YEL)
14	CN74	AC LOAD-1	YW396-03AV(RE D)
15	CN11	AC POWER	YW396-03AV(WHT)

## 10-2 Outdoor PCB

### AQX36VFUAGM/CV -OUTDOOR EMI PCB

⚠ The red number connector is not used.

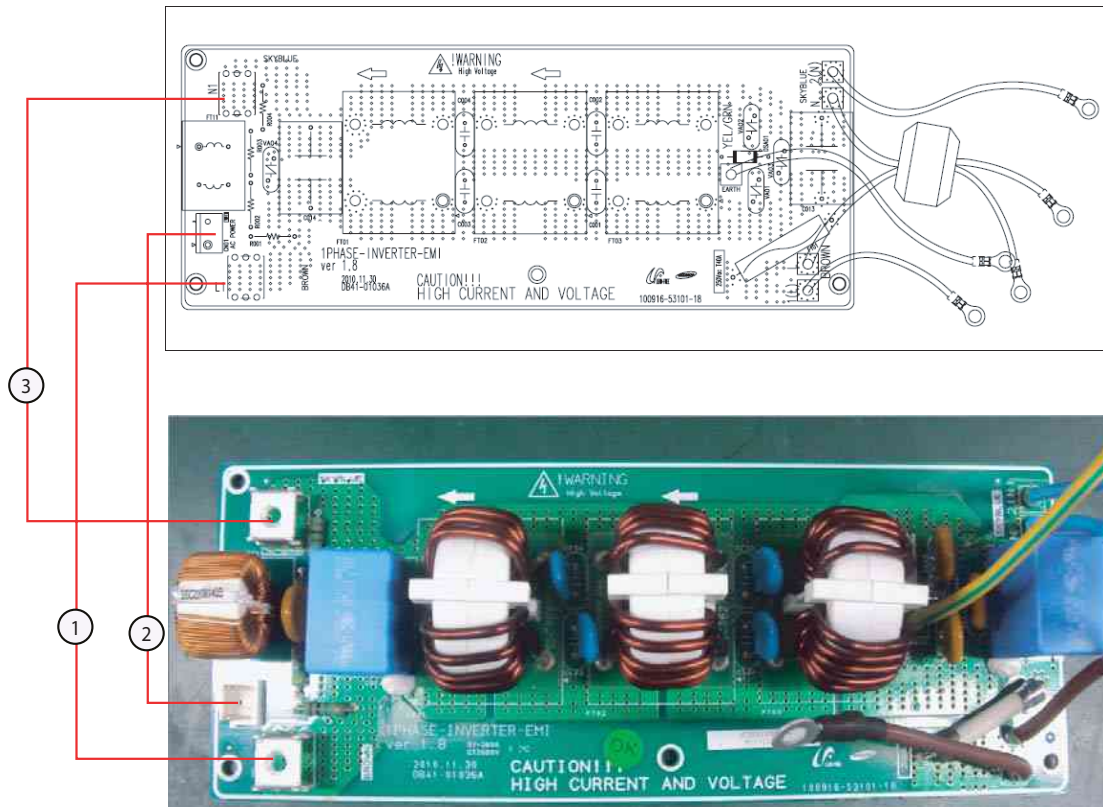

NO	LOCATION	NAME	SPEC
1	N1	N1	OT-048
2	CN01	AC POWER	YW396-03AV(WHT)
3	L1	L1	OT-048



## 10-2 Outdoor PCB

### AQX36VFUAGM/CV –OUTDOOR INVERTER PCB

 The red number connector is not used.

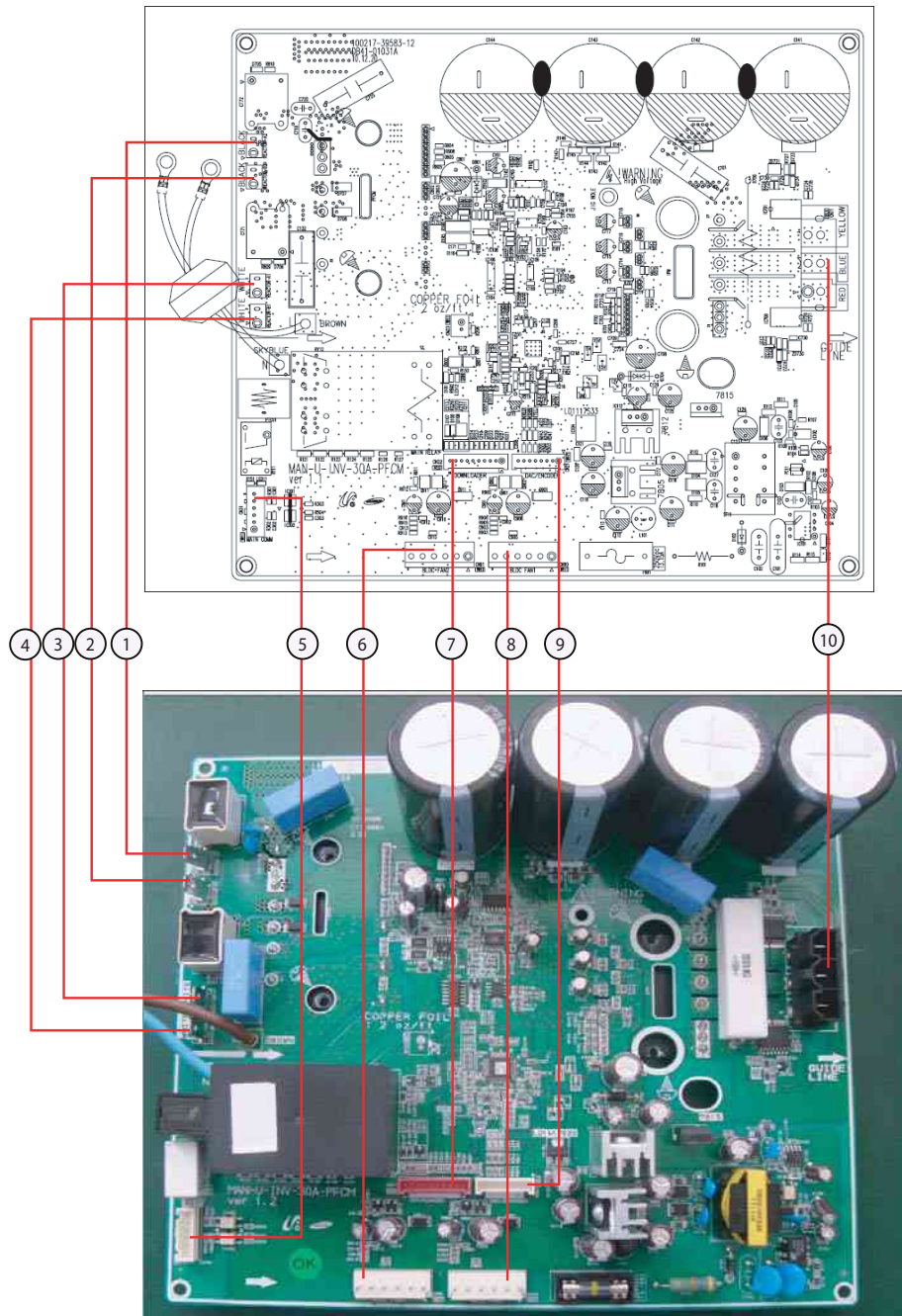

NO	LOCATION	NAME	SPEC
1	REACTOR-A2	REACTOR-A2	YTR250
2	REACTOR-B2	REACTOR-B2	YTR250
3	REACTOR-A1	REACTOR-A1	YTR250
4	REACTOR-B1	REACTOR-B1	YTR250
5	CN31	MAIN COMM	SMW250-06(WHT)
6	CN91	BLDC FAN2	YW396-06V(WHT)
7	CN22	DOWNLOADER	SMW200-10(RED)
8	CN90	BLDC FAN1	YW396-06V(WHT)
9	CN21	DAC/ENCODER	SMW200-08P(WHT)
10	CN71	RED/BLUE/YELLOW	HLW1005-03(BLK)

## 10-2 Outdoor PCB

### AQX36VFUAGM/CV –OUTDOOR INVERTER PCB

⚠ The red number connector is not used.

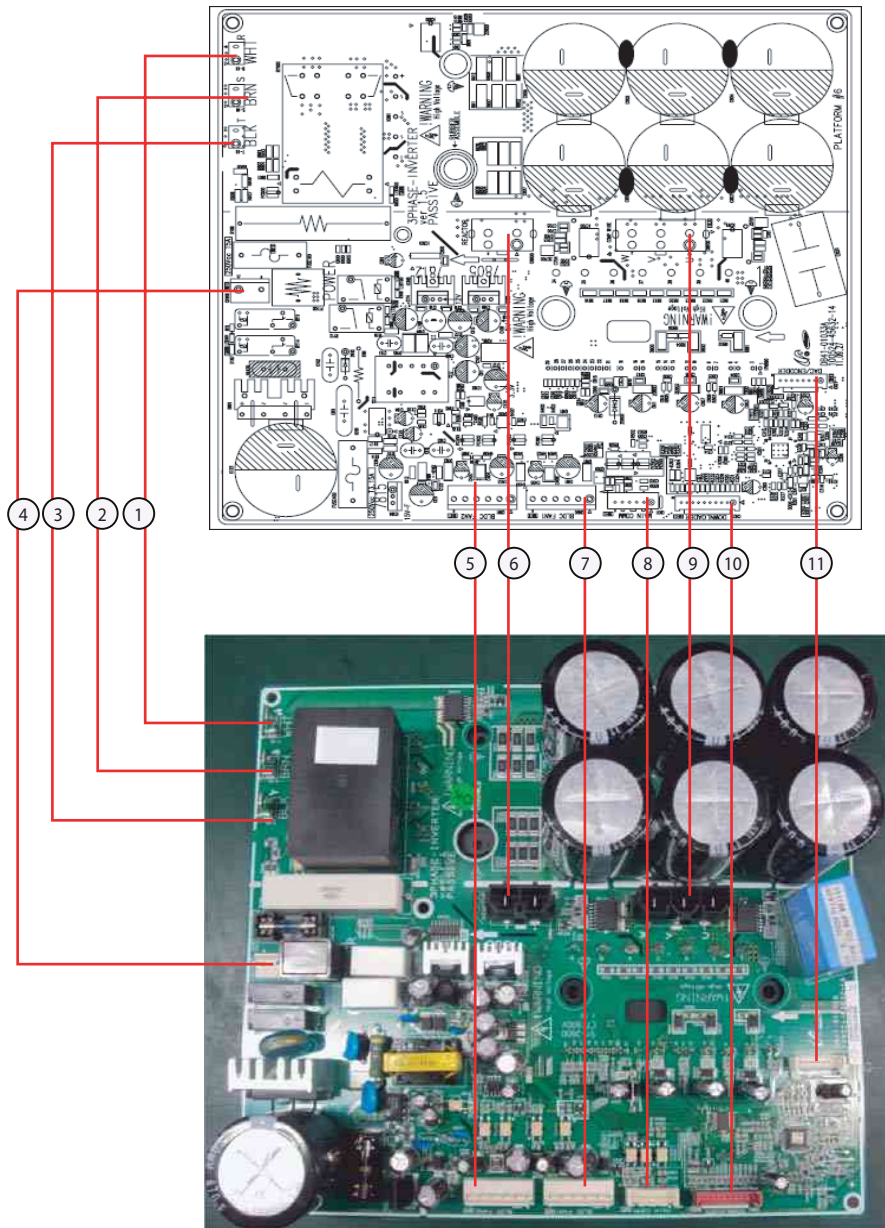

NO	LOCATION	NAME	SPEC
1	R	R-IN	YTR250
2	S	S-IN	YTR250
3	T	T-IN	YTR250
4	CN100	CN100	YW396-03AV(WHT)
5	CN91	BLDC FAN2	YW396-06V(WHT)
6	CN600	REACTOR	HLW1005-02(BLK)
7	CN90	BLDC FAN1	YW396-06V(WHT)
8	CN31	MAIN COMM	SMW250-06(WHT)
9	CN800	U/V/W	HLW1005-03(BLK)
10	CN22	DOWNLOADER	SMW200-10(RED)
11	CN21	DAC/ENCODER	SMW200-08P(WHT)

# New Function [ Indoor Terminal Block Safety Device ]

## 1. Thermal Fuse is installed in Terminal Block as below.

(Thermal Fuse is used to prevent PL caused by a defective connection of indoor and outdoor units)



Terminal Block Internals



Connection of terminal block and Main PBA

## 2. Thermal Fuse is opened when internal temperature of Terminal Block goes to a certain point due to Tracking caused by a defective connection of indoor and outdoor units.

- When Thermal Fuse is opened, Main PBA (DC12V) is turned off and the indoor unit does not operate. (There is no problem with Main PBA in this case)
- In the above case, the change of all-in-one Terminal Block will make Main PBA operate again.

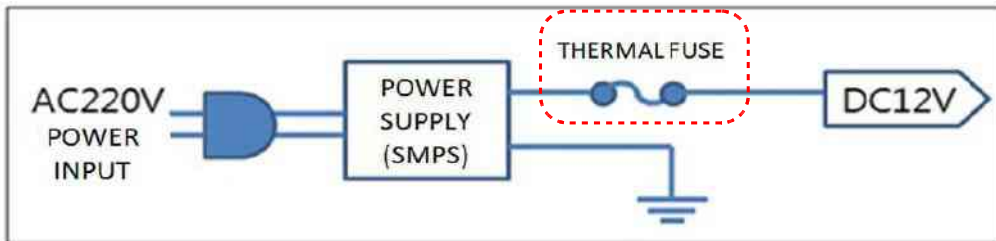

Circuit Block

## 3. Measurement method of fair/defective thermal fuse



Fair



Defective

---

# 11. Operating Instructions

---

## 11-1 Name of Each Part

---

### 11-1-1 Indoor Unit

The design and shape are subject to change according to the model.

Main parts

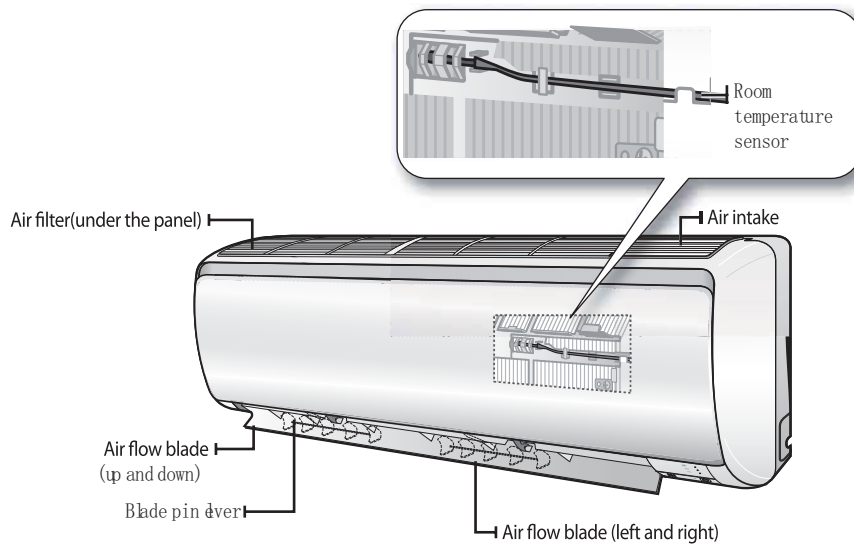



### 11-1-2 Outdoor Unit



## 11-2 Wireless Remote Control-Buttons and Display

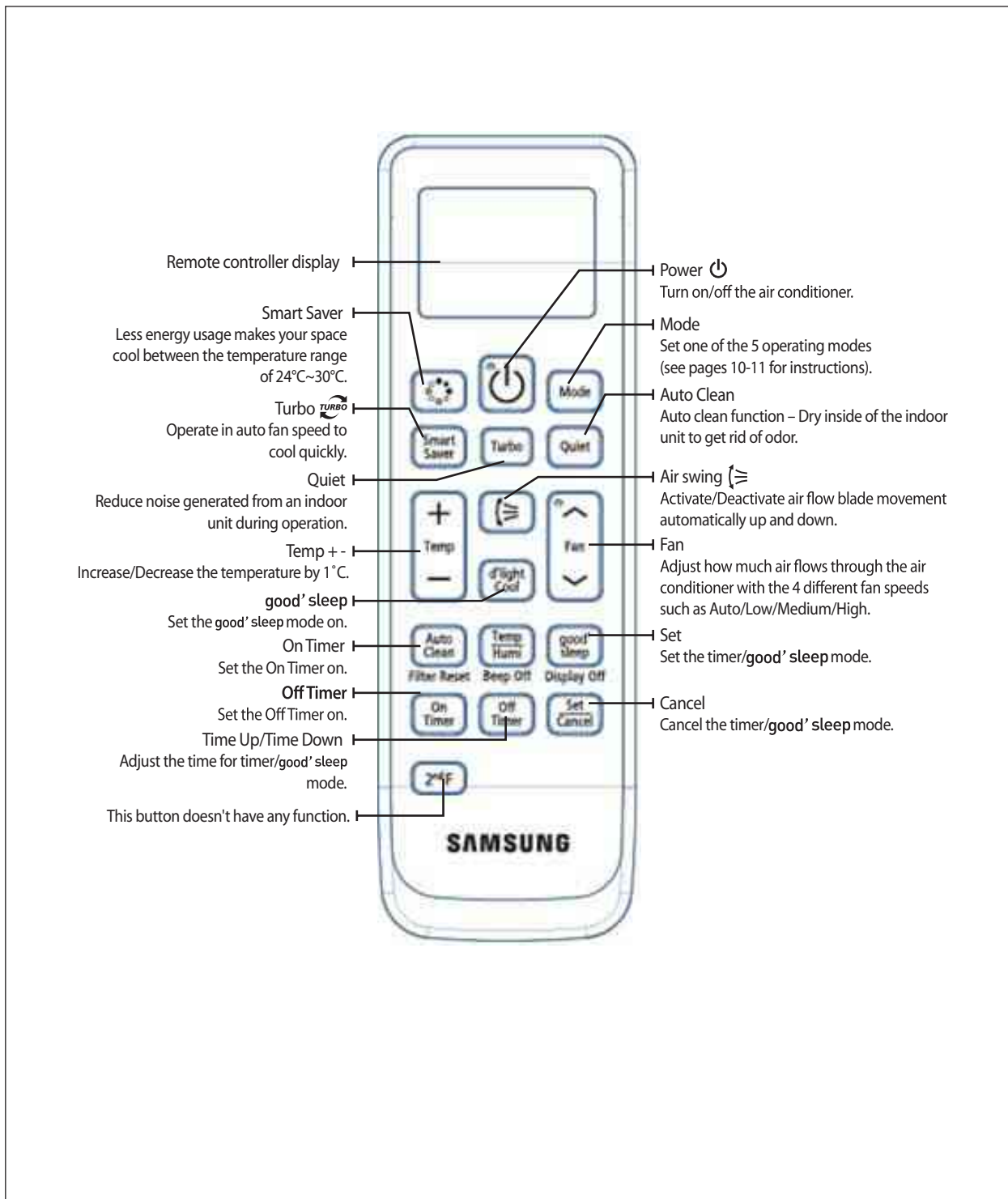

## 12. Troubleshooting

### 12-1 Items to be checked first

- The input voltage should be rating voltage  $\pm 10\%$  range.  
The air conditioner may not operate properly if the voltage is out of this range.
- Is the link cable linking the indoor unit and the outdoor unit linked properly?  
The indoor unit and the outdoor unit shall be linked by 5 cables.  
Check the terminals if the indoor unit and outdoor unit are properly linked by the same number of cables.  
Otherwise the air conditioner may not operate properly.
- When a problem occurs due to the contents illustrated in the table below it is a symptom not related to the malfunction of the air conditioner.

No	Operation of air conditioner	Explanation
1	The OPERATION indication LE $\boxtimes$ (BLUE) blinks when a power plug of the indoor unit is plugged in for the first time.	It indicates power is on. The LE $\boxtimes$ stops blinking if the operation ON/OFF button on the remote control unit is pushed.
2	In a COOL operation mode, the compressor does not operate at a room temperature higher than the setting temperature that the IN $\boxtimes$ DOOR FAN should operate. <b>[In case of heat pump model]</b> In a HEAT operation mode, the compressor does not operate at a room temperature lower than the setting temperature that indoor fan should operate.	In happens after a delay of 3 minutes when the compressor is reoperated. The same phenomenon occurs when a power is on. As a phenomenon that the compressor is reoperated after a delay of 3 minutes, the indoor fan is adjusted automatically with reference to a temperature of the air blew.
3	Fan speed setting is not allowed in $\boxtimes$ RY ( $\boxtimes$ ) mode.	The speed of the indoor fan is set to LL in $\boxtimes$ RY mode. Fan speed is selected automatically in AUTO mode.
4	Compressor stops operation intermittently in $\boxtimes$ RY ( $\boxtimes$ ) mode.	Compressor operation is controlled automatically in $\boxtimes$ RY mode depending on the room temperature and humidity.
5	Timer LE $\boxtimes$ (ORANGE) of the indoor unit lights up and the air conditioner does not operate.	Timer is being activated and the unit is in ready mode. The unit operates normally if the timer operation is cancelled.
6	The compressor stops intermittently in a COOL mode or $\boxtimes$ RY mode, and fan speed of the indoor unit decreases.	The compressor stops intermittently or the fan speed of the indoor unit decreases to prevent inside/outside air frozen depending on the inside/outside air temperature.
7	<b>[In case of heat pump model]</b> Compressor of the outdoor unit is operating although it is turned off in a HEAT mode.	When the unit is turned off while de-ice is activated, the compressor continues operation for up to 9 minutes(maximum) until the deice is completed.
8	<b>[In case of heat pump model]</b> The compressor and indoor fan stop intermittently in HEAT mode.	The compressor and indoor fan stop intermittently if room temperature exceeds a setting temperature in order to protect the compressor from overheated air in a HEAT mode.
9	<b>[In case of heat pump model]</b> Indoor fan and outdoor fan stop operation intermittently in a HEAT mode.	The compressor operates in a reverse cycle to remove exterior ice in a HEAT mode, and indoor fan and outdoor fan do not operate intermittently for within 20% of the total heater operation

## 12-2 Fault Diagnosis by Symptom

Communication error

Indoor display				Communication error
Outdoor display				Imin. Time out Comm.
				Abnormal Communication

1. Checklist :

- 1) Is the cable between the indoor unit and outdoor unit connected correctly?
- 2) Isn't the power cable and communication cable cross?

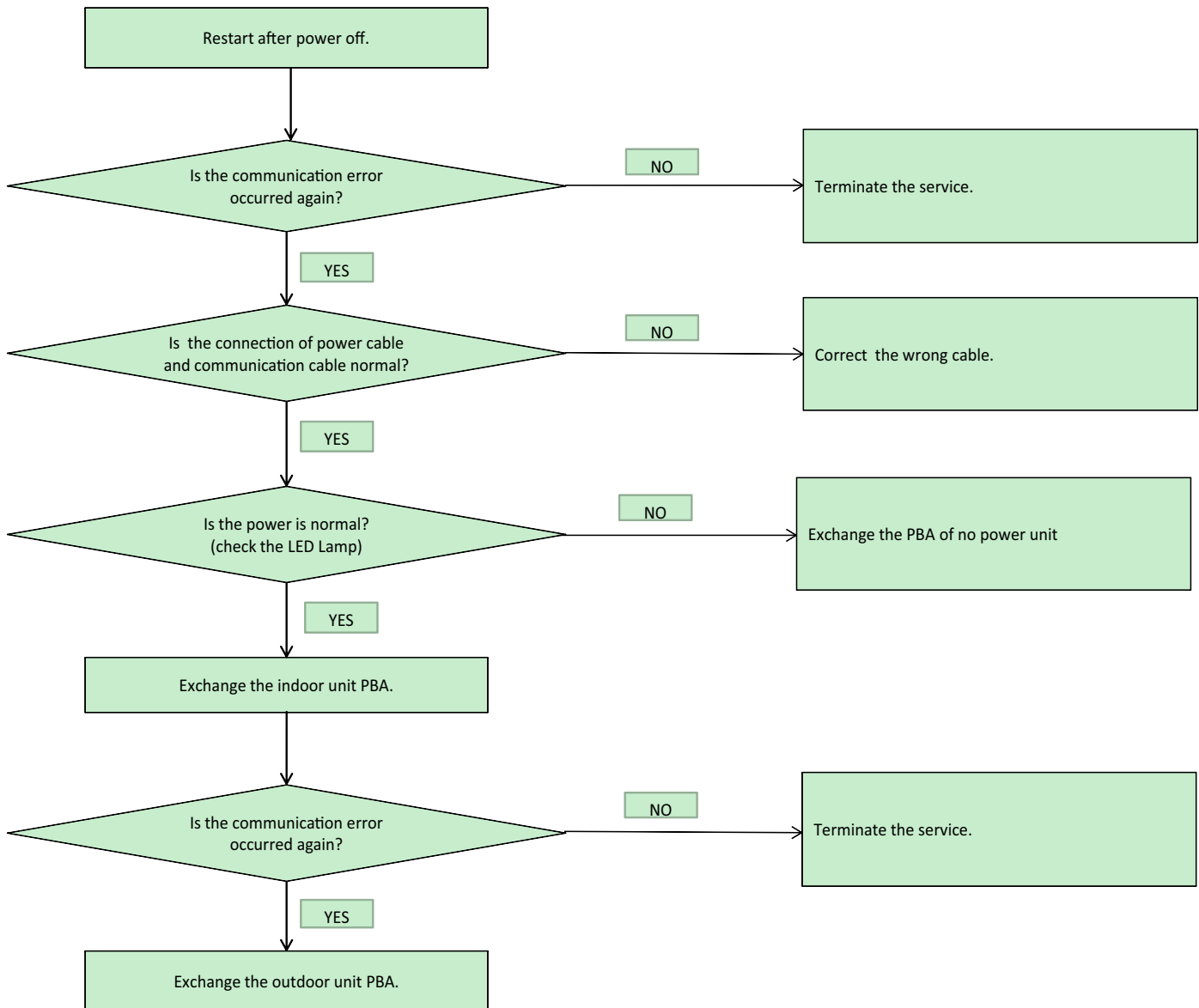

Indoor temperature sensor error

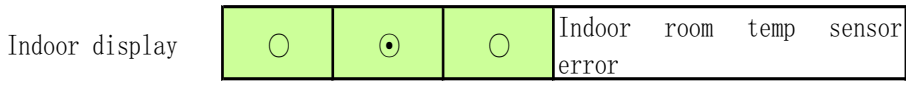

1. Checklist :

- 1) Is the indoor units temperature sensor connected correctly?
- 2) Is the sensor placed correctly?
- 3) Does the both terminal of sensor satisfy the resistance value in accordance with temperature?

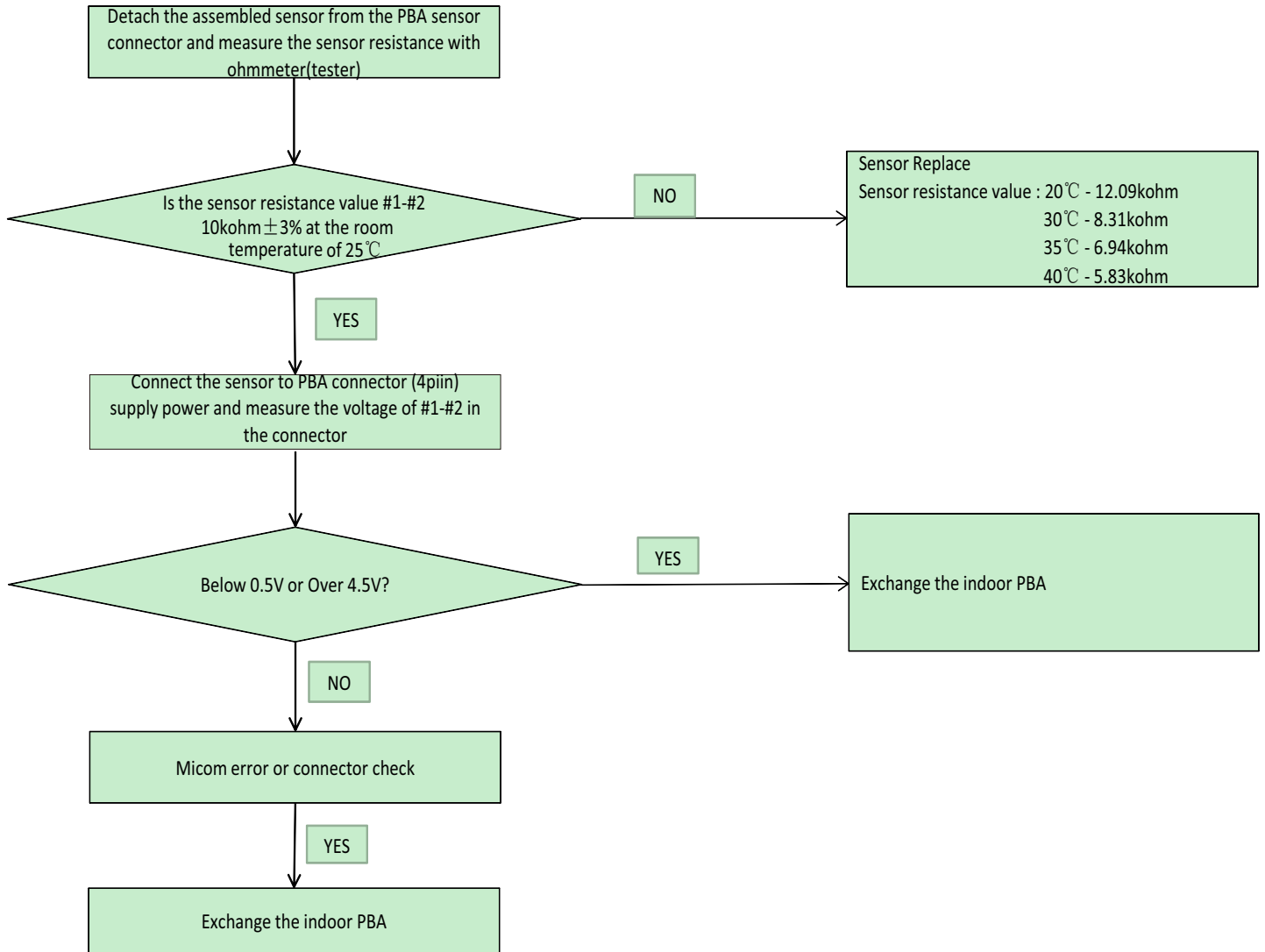

Indoor Eva-in temperature sensor error

Indoor display	●	●	○	Indoor Eva-in temp sensor error
----------------	---	---	---	---------------------------------

1. Checklist :

- 1) Is the indoor units temperature sensor connected correctly?
- 2) Is the sensor placed correctly?
- 3) Does the both terminal of sensor satisfy the resistance value in accordance with temperature?

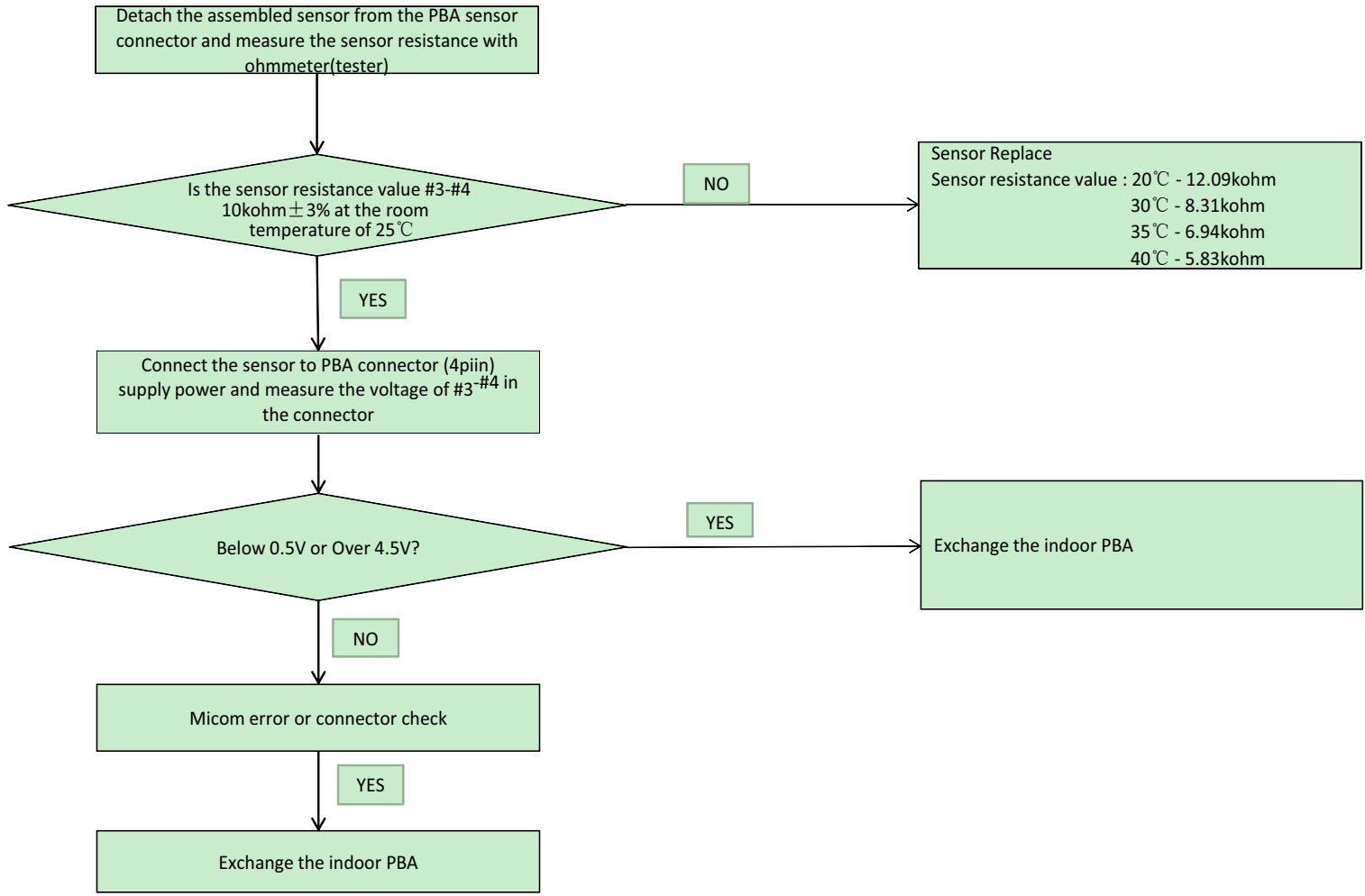

When the Up/Down louver motor does not operate (Initial Diagnosis) (Not displayed)

1. Checklist :

- 1) Is the input power voltage normal?
- 2) Is the Up/Down louver motor properly connected with the connector? (CN61)

2. Troubleshooting procedure

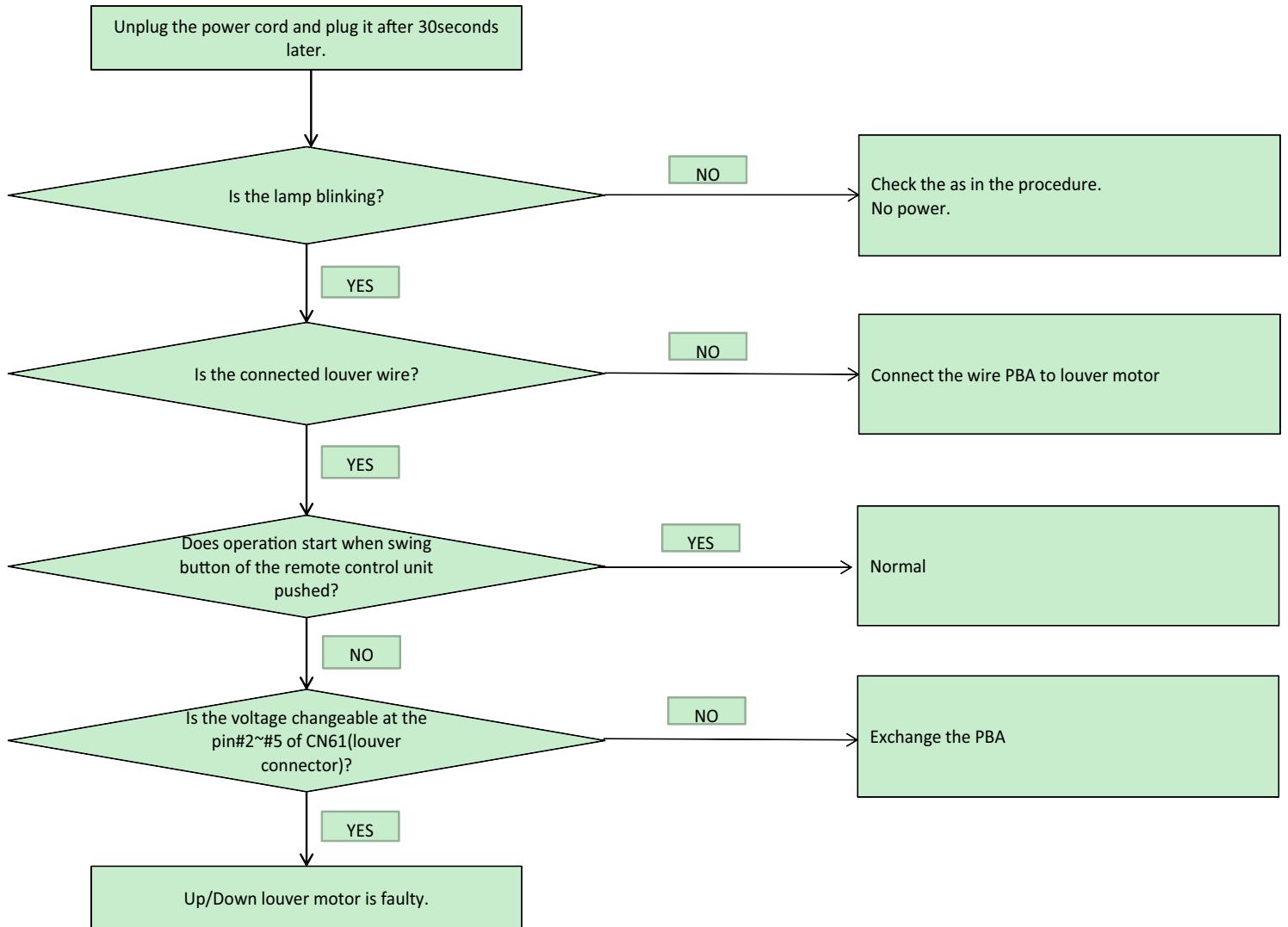

When the remote control is not receiving

1. Checklist :

- 1) Check if the connector was normally assembled.
- 2) Check the battery in remote control
- 3) All the lights out and check again : Change electronic typed to a fluorescent
- 4) Put the set in operation and check the voltage of display PBA
- 5) Replace the display PBA



Indoor fan motor speed detecting error (BLDC fan)

Indoor display 

<input type="radio"/>	<input type="radio"/>	<input checked="" type="radio"/>	Indoor fan error
-----------------------	-----------------------	----------------------------------	------------------

1. Checklist :

- 1) Is the indoor units fan motor properly connected with the connector(CN72)?
- 2) Is the AC voltage correct?

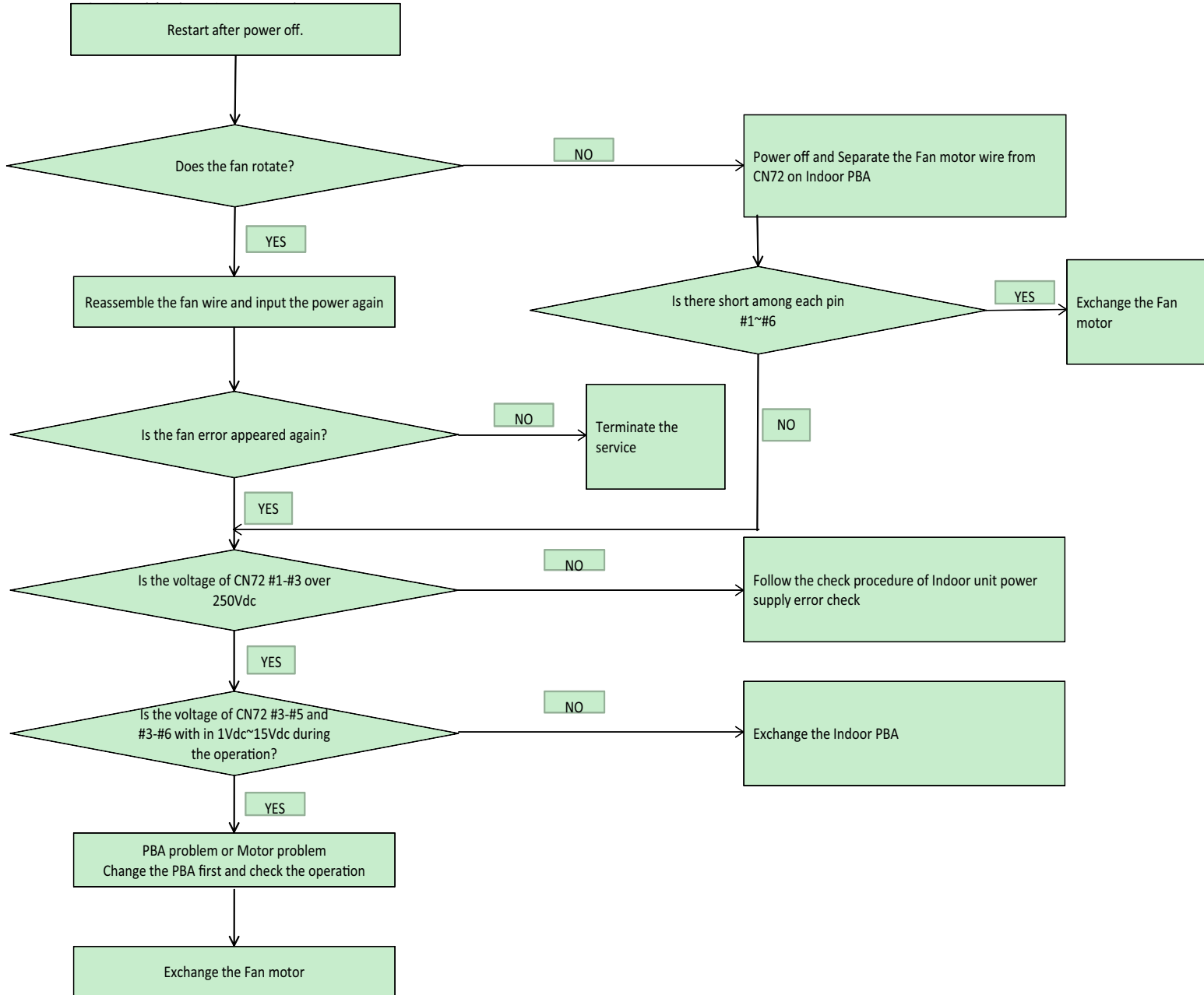

Outdoor temperature sensor error

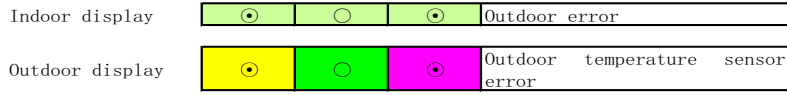

1. Checklist :

- 1) Is the sensor connected correctly?
- 2) Is the sensor placed correctly?
- 3) Does the both terminal of sensor satisfy the resistance value in accordance with temperature?
- 4) Is the resistance value of sensor connection pull-up correct?

2-1. Troubleshooting procedure (A\*V18\*\*\*)

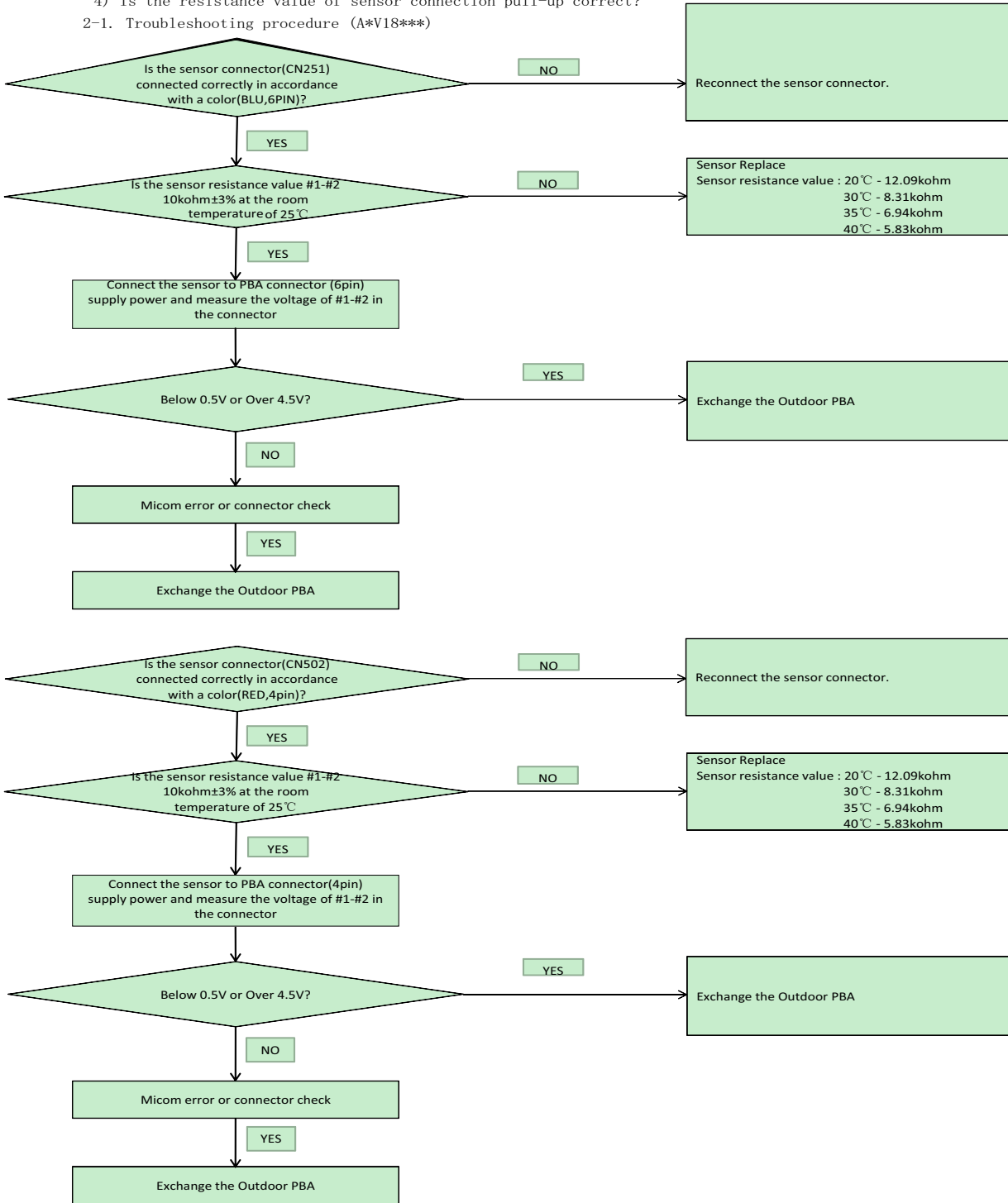

Temperature-Resistance

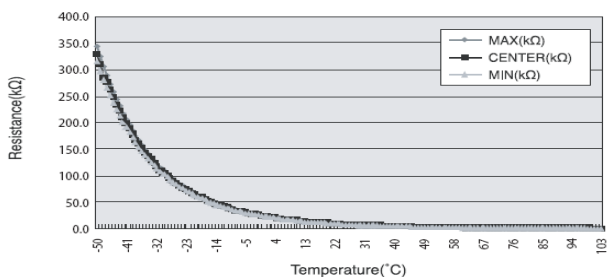

Outdoor Coil temperature sensor error

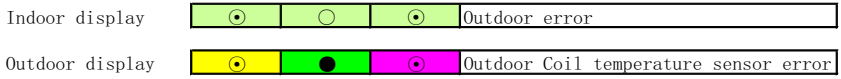

1. Checklist :

- 1) Is the sensor connected correctly?
  - 2) Is the sensor placed correctly?
  - 3) Does the both terminal of sensor satisfy the resistance value in accordance with temperature?
  - 4) Is the resistance value of sensor connection pull-up correct?
- 2-1. Troubleshooting procedure (A\*V18\*\*\*)

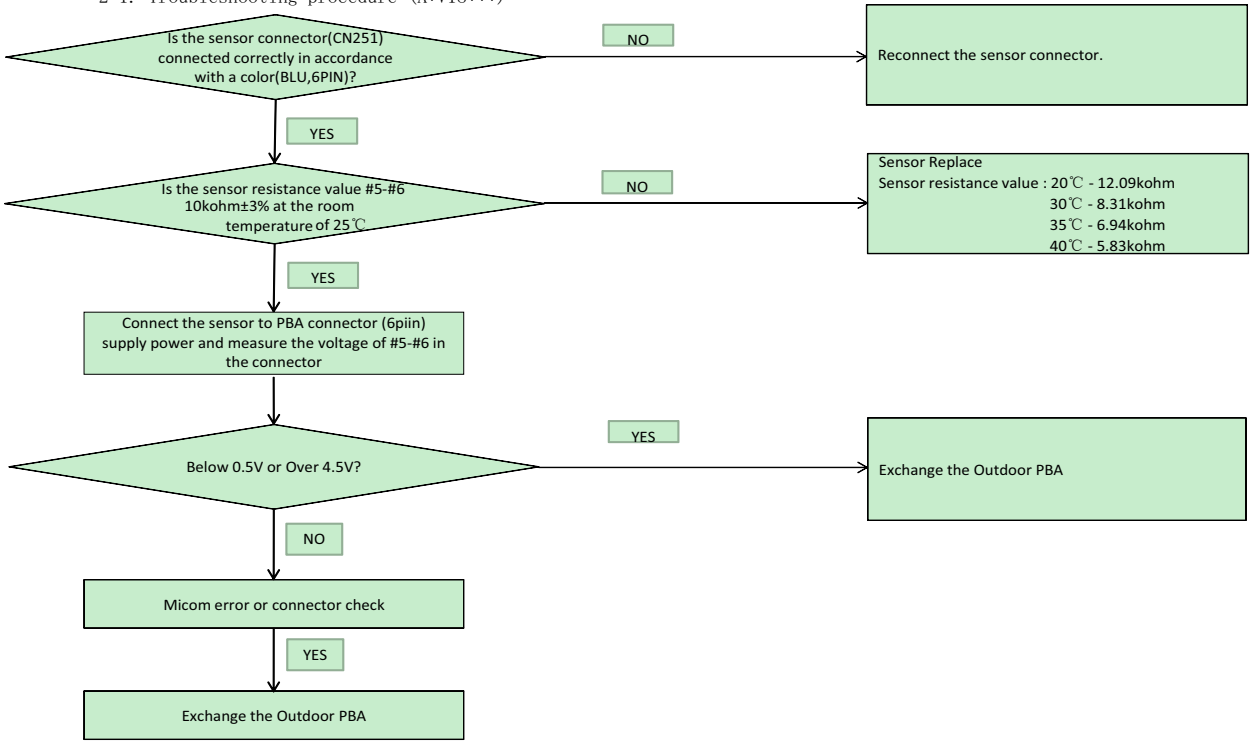

2-2. Troubleshooting procedure (A\*V24\*\*\*)

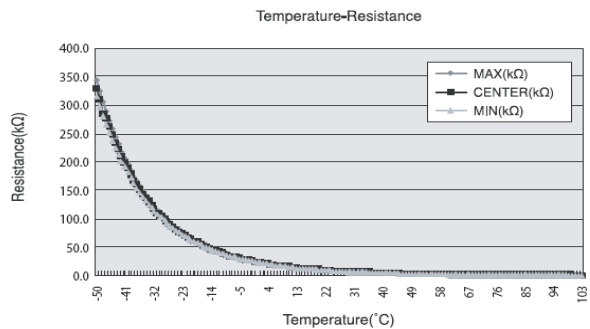
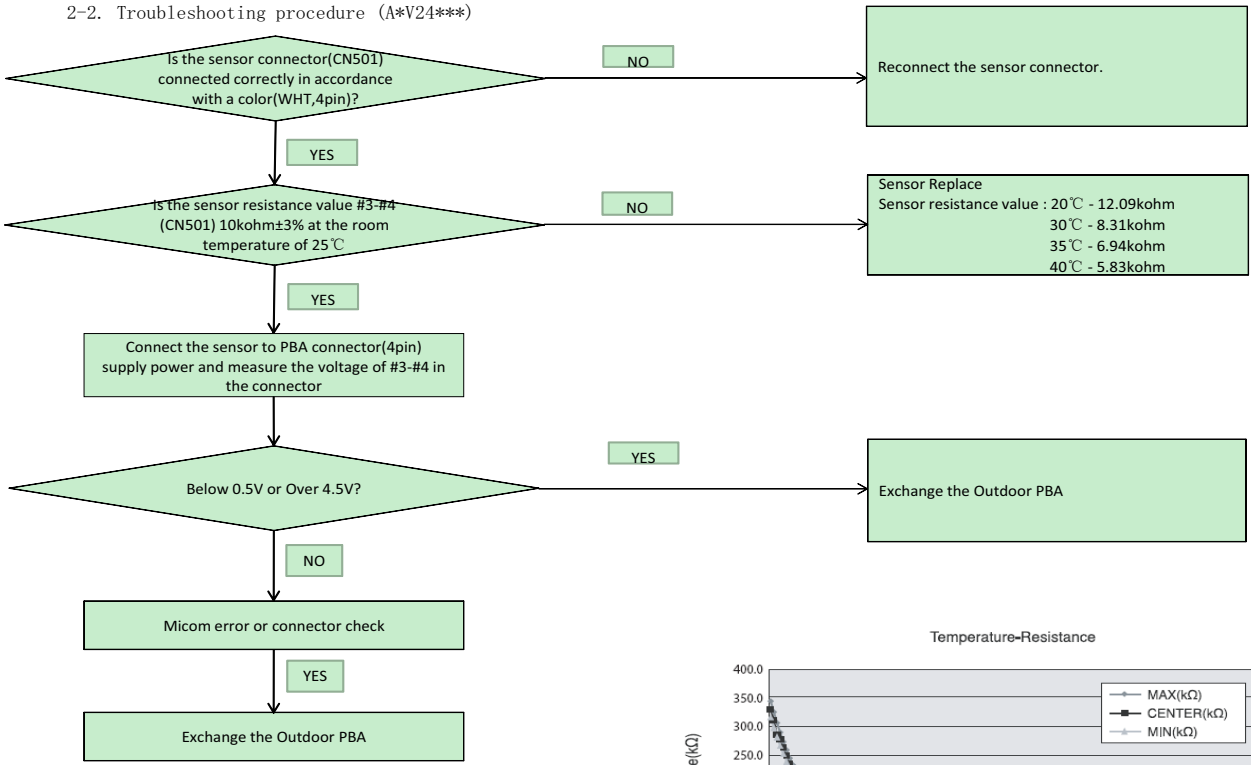

Outdoor Discharge temperature sensor error

Indoor display ● ○ ● Outdoor error

Outdoor display ● ● ○ Outdoor Discharge temperature sensor error

1. Checklist :

- 1) Is the sensor connected correctly?
- 2) Is the sensor placed correctly?
- 3) Does the both terminal of sensor satisfy the resistance value in accordance with temperature?
- 4) Is the resistance value of sensor connection pull-up correct?

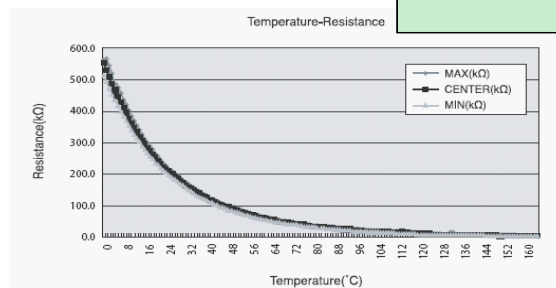
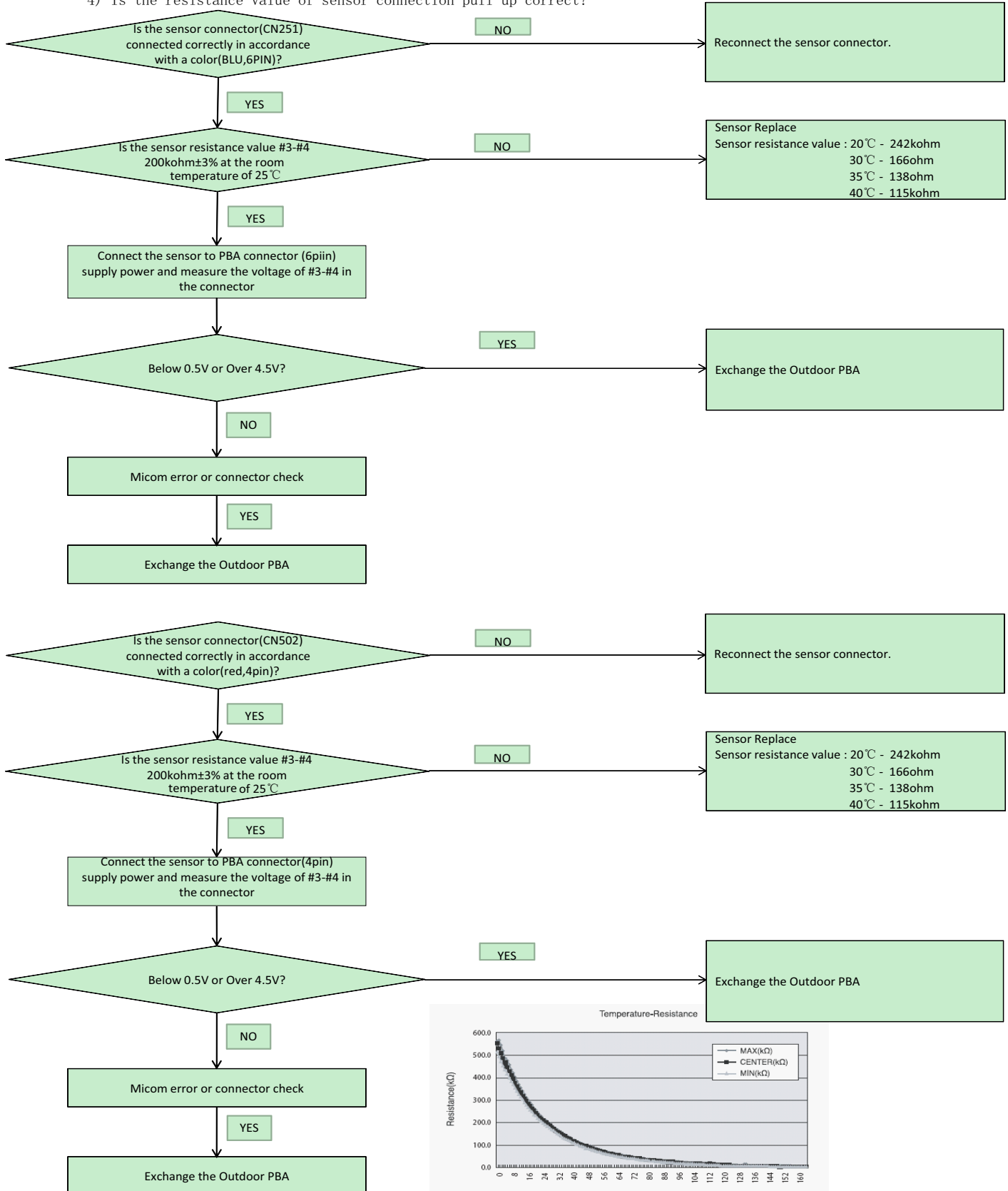

Outdoor Discharge over temperature error

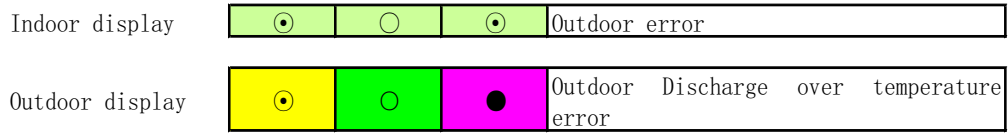

1. Checklist :

- 1) Check the discharge temperature in the outdoor unit
- 2) Check the compressor locking or gas leak
- 3) Download the EEPROM data

2. Troubleshooting procedure

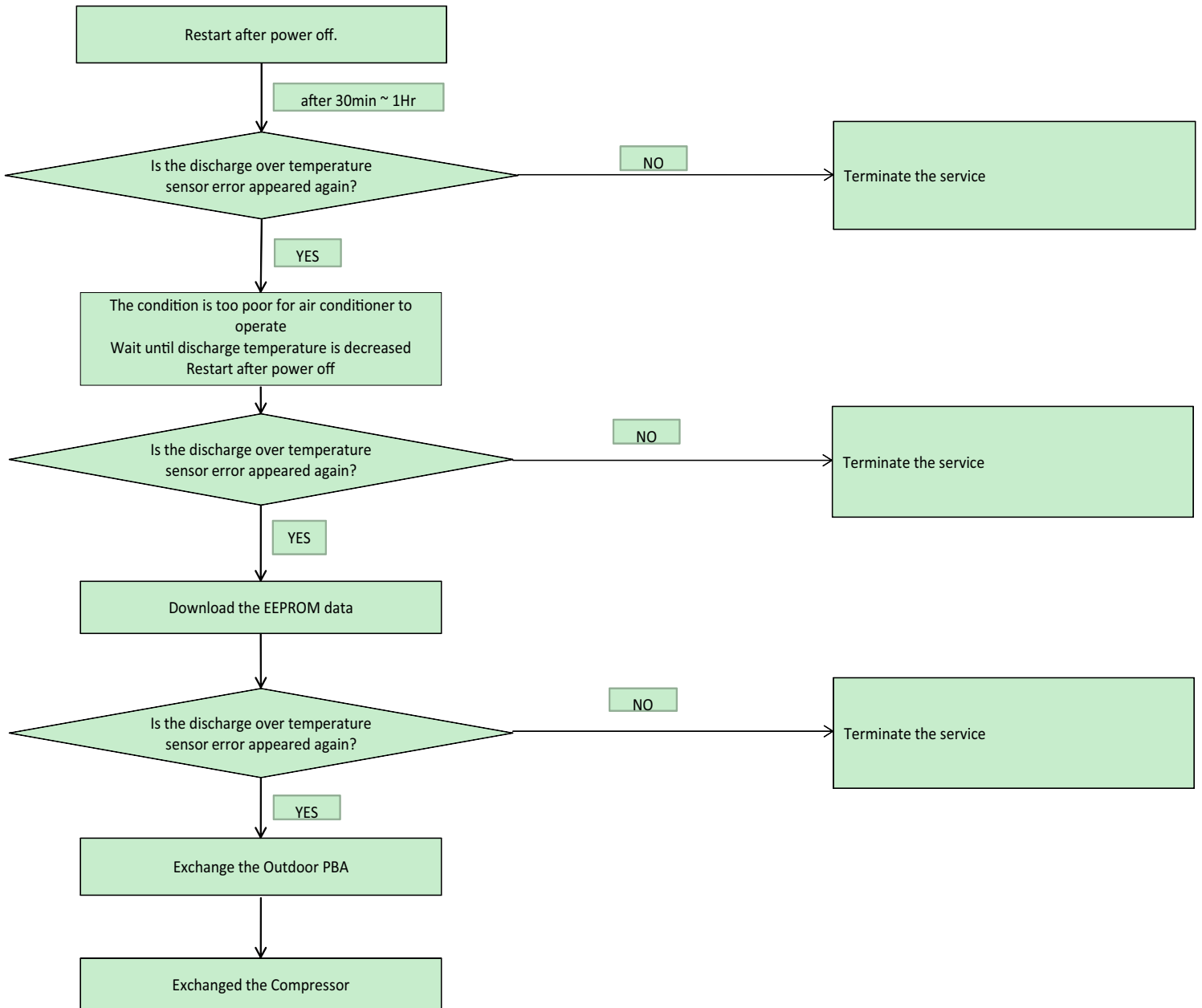

Outdoor Fan motor error

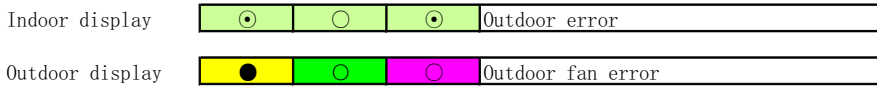

1. Checklist :

- 1) Are the input power voltage and the power connection correct?
- 2) Is the motor wire connected to the outdoor PBA correctly?
- 3) Is there no assembly error or none-assembly in the terminal of motor wire connector?
- 4) Is there no obstacle at the surrounding of motor and propeller?

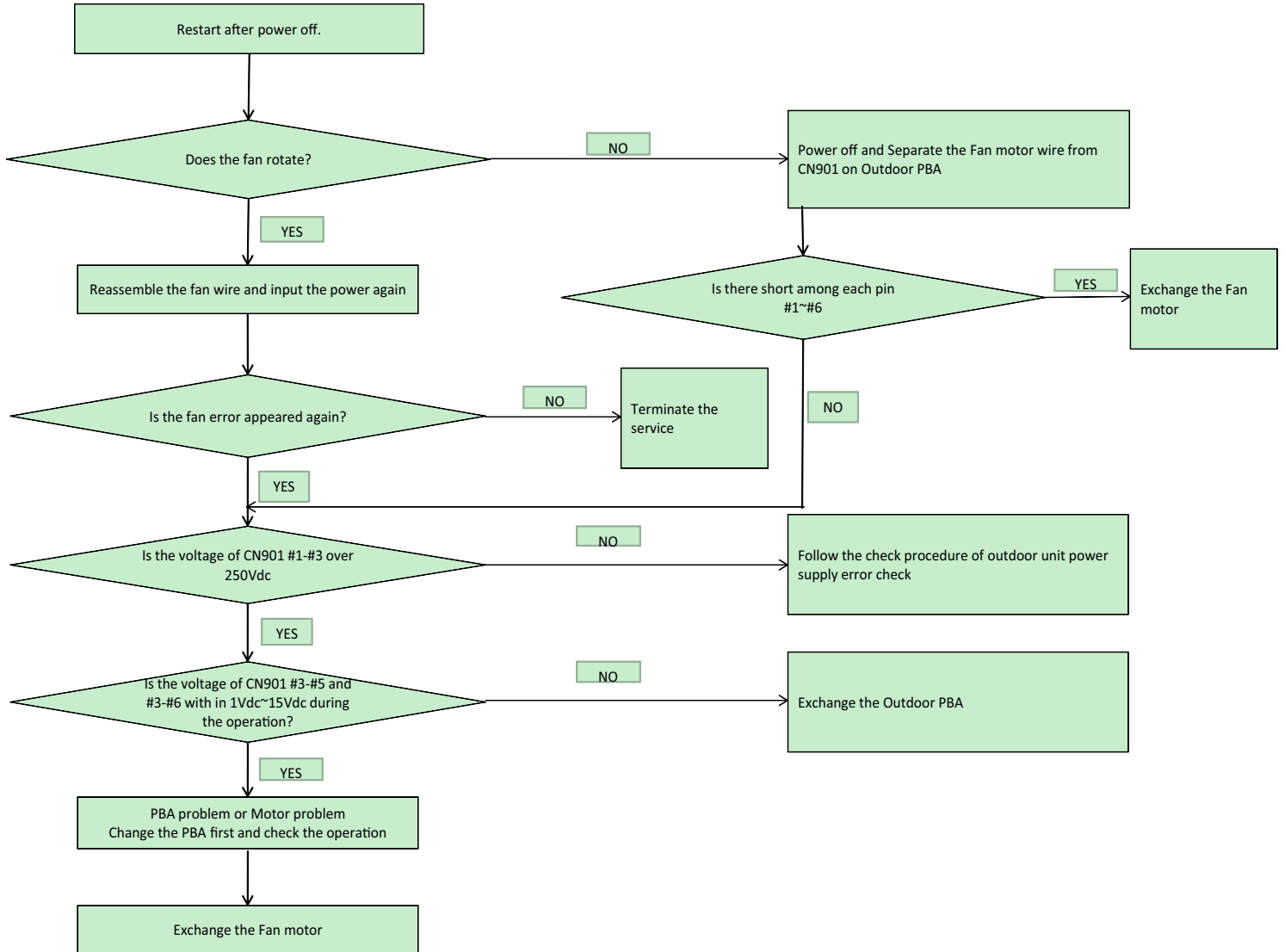

Compressor starting error

Indoor display  Outdoor error

Outdoor display  Comp starting error

1. Checklist :

- 1) Is the connection of cable for the compressor?
- 2) Is the compressor wire is connected clockwise? U(RED)-V(BLU)-W(YEL)
- 3) Is the interphase resistance of compressor normal?

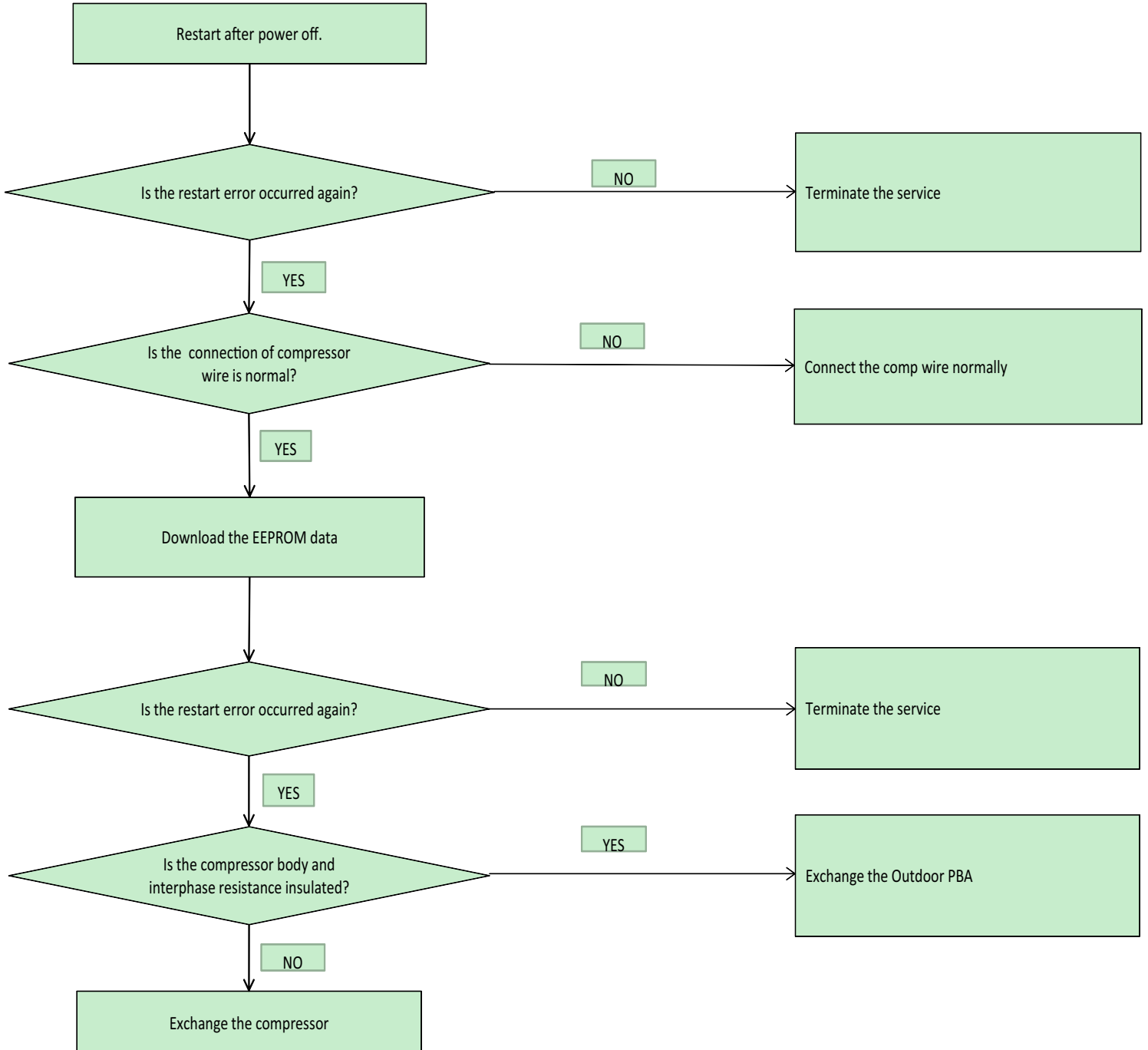

Compressor wire missing error/rotation error

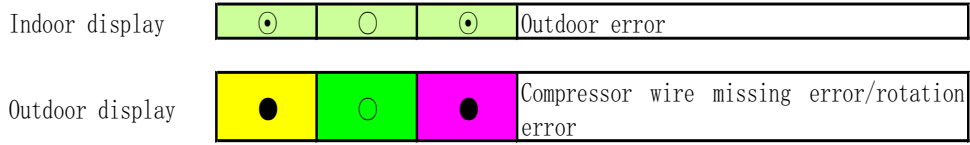

1. Checklist :

- 1) Is the connection of cable for the compressor?
- 2) Is the compressor wire is connected clockwise? U (RED)-V (BLU)-W (YEL)
- 3) Is the interphase resistance of compressor normal?

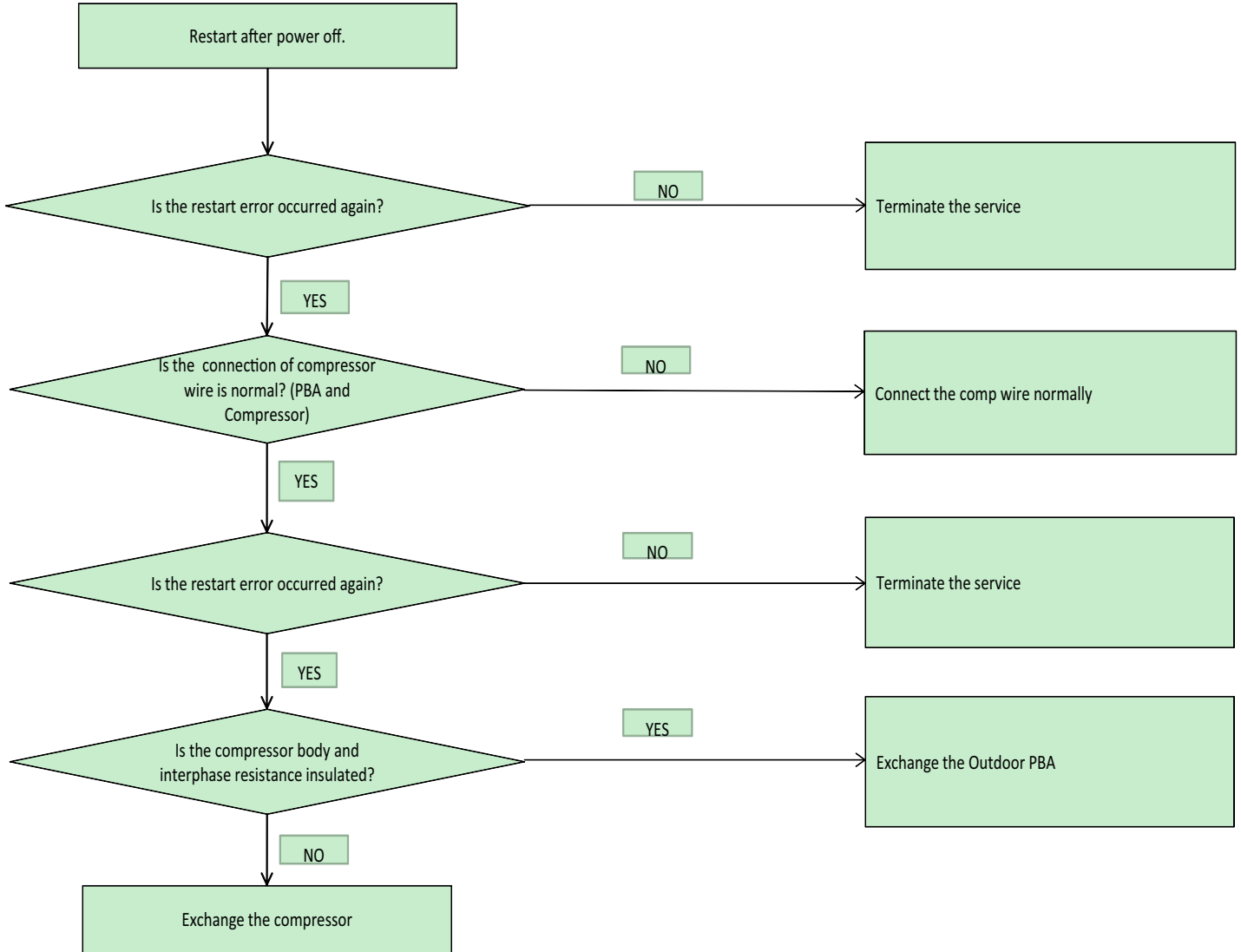

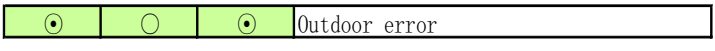

O.C(Over Current) error

Indoor display  Outdoor error

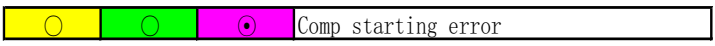
Outdoor display  Comp starting error

1. Checklist :

- 1) Is the IPM Shunt (A\*V18\*\*\*:R451, R452, R453, A\*V24\*\*\*:R413, R414, R415) resistance value correct? Check the resistor is opened
- 2) Is the condition of surrounding temperature abnormal overload?
- 3) Is there any problem as like the temperature sensor separation or measurement value error?
- 4) Is the interphase resistance of compressor normal?

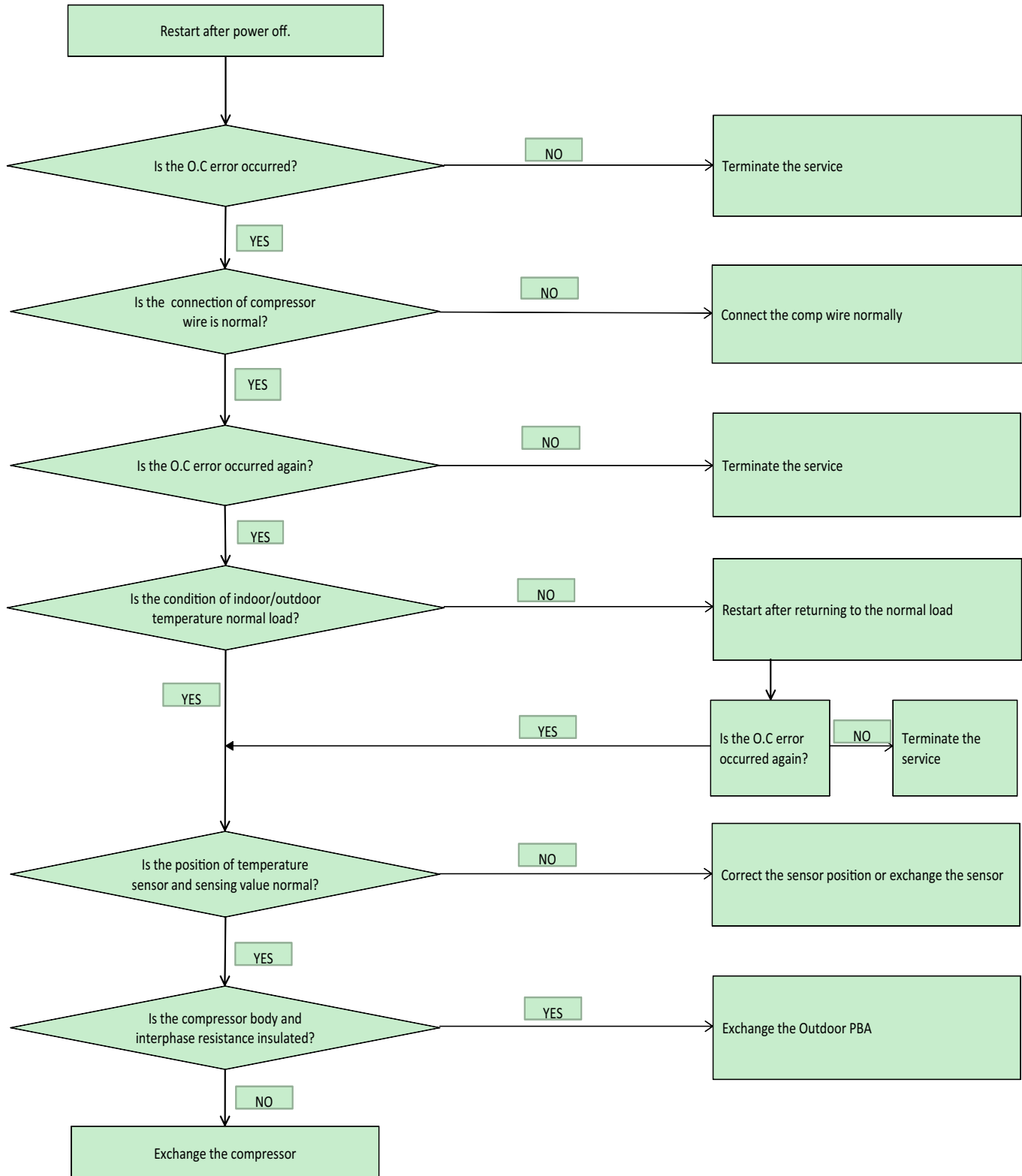

DC\_link voltage sensor error

Indoor display    Outdoor error

Outdoor display    DC link voltage sensor error

1. Checklist :

- 1) Is the input voltage of outdoor terminal block is normal?
- 2) Is the reactor wire connected?
- 3) Is the DC\_link capacitor (A\*V18\*\*\*:CE101, CE102, CE103, A\*V24\*\*\*:CE001, CE002, CE003, CE004) assembled in accordance the specification? (Outdoor PBA)
- 4) Is the DC\_link resistor (A\*V18\*\*\*:R104, R106, R107, R108, A\*V24\*\*\*:R004, R005, R006, R007) value is normal? (Outdoor PBA)

2. Troubleshooting procedure

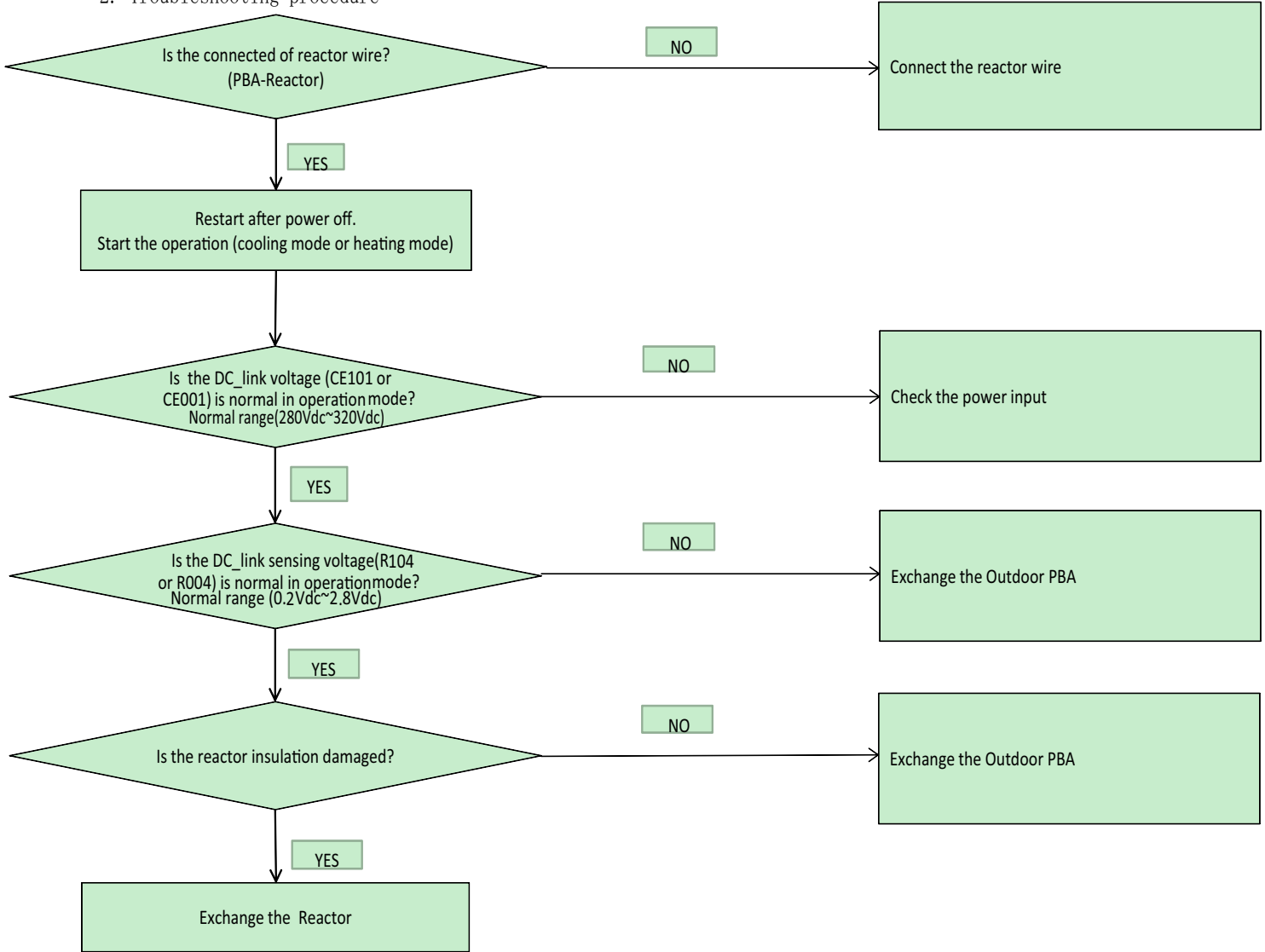

DC\_link voltage under/over error, Over voltage protection error/PFC over load

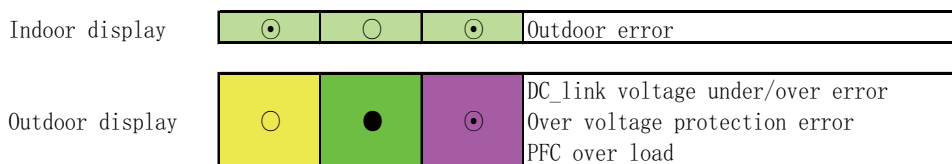

1. Checklist :

- 1) Is the input voltage of outdoor terminal block is normal?
  - 2) Is the input voltage is higher than 300Vac?
  - 3) Is the reactor wire connected?
  - 3) Is the DC\_link capacitor(A\*V18\*\*\*:CE101, CE102, CE103, A\*V24\*\*\*:CE001, CE002, CE003, CE004) assembled in accordance the specification? (Outdoor PBA)
  - 4) Is the DC\_link resistor(A\*V18\*\*\*:R104, R106, R107, R108, A\*V24\*\*\*:R004, R005, R006, R007) value is normal? (Outdoor PBA)
2. Troubleshooting procedure

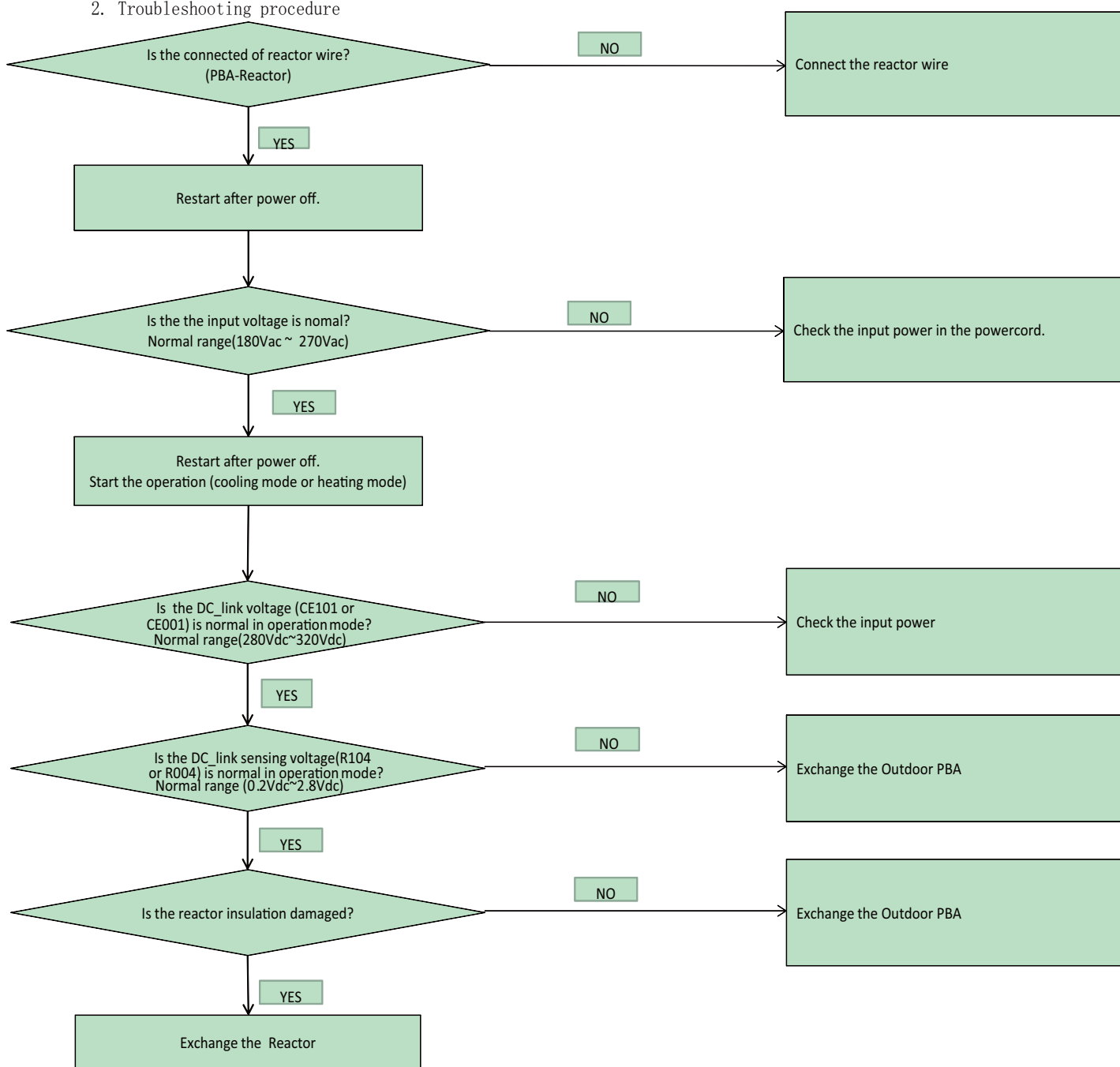

I\_trip error, PFC over current

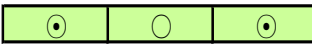
Indoor display  Outdoor error

Outdoor display  I\_trip error, PFC over current

1. Checklist :

- 1) Is the PFC Shunt (A\*V18\*\*\*:R062, R063, A\*V24\*\*\*:R807, R808, R809) resistance value correct? Check the resistor is opened
- 2) Is the condition of surrounding temperature abnormal overload?
- 3) Is there any problem as like the temperature sensor separation or measurement value error?
- 4) Is the interphase resistance of compressor normal?

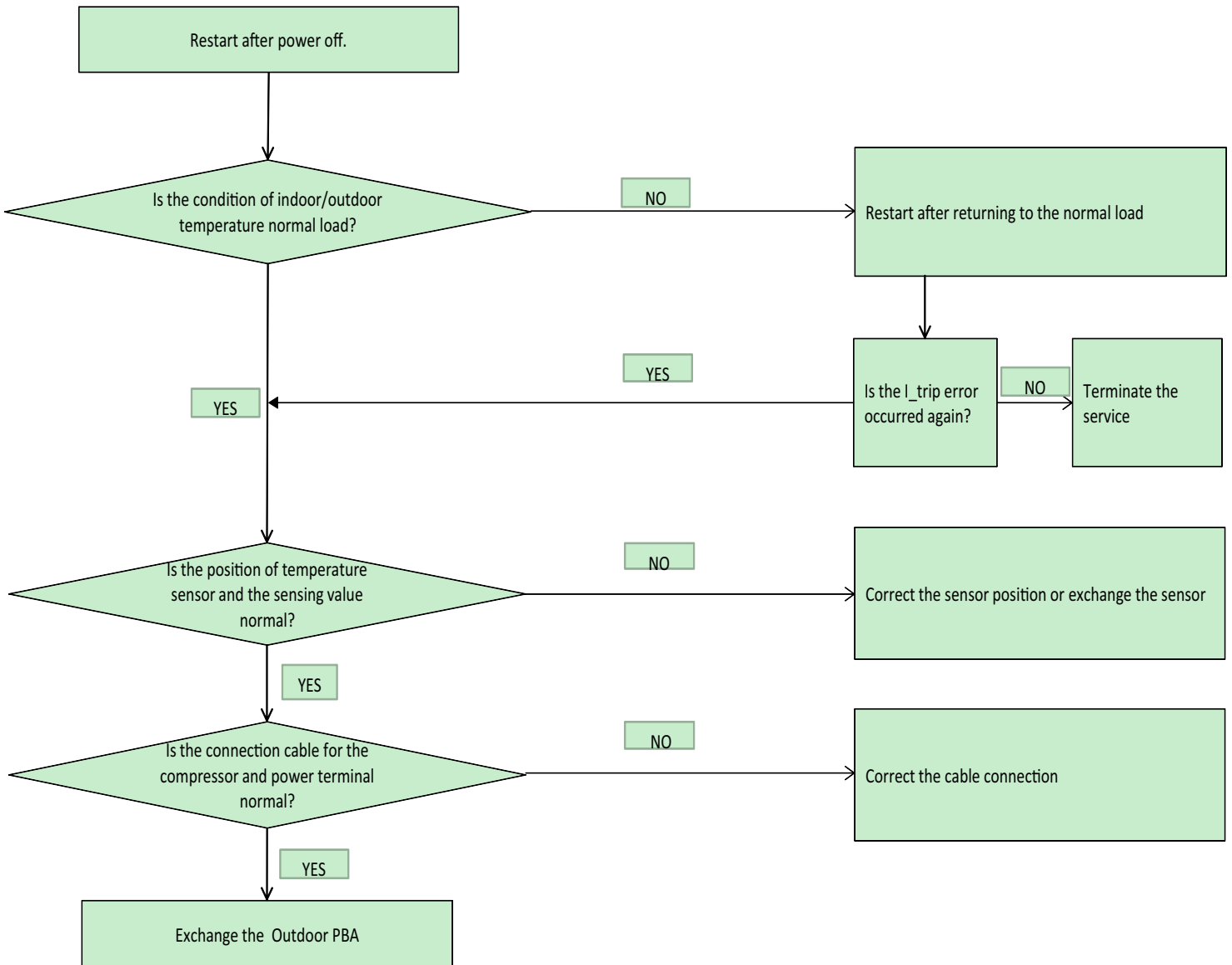

Current sensor error/Input current sensor error

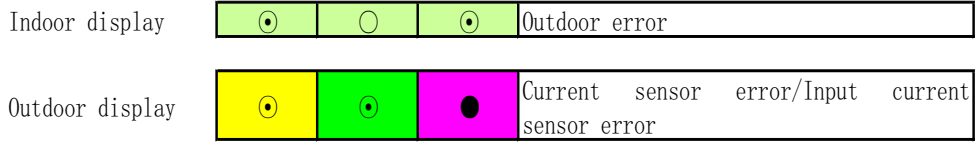

1. Checklist :

- 1) Is the PFC Shunt (A\*V18\*\*\*:R062, R063, A\*V24\*\*\*:R807, R808, R809) resistance value correct? Check the resistor is opened
- 2) Is the IPM Shunt (A\*V18\*\*\*:R451, R452, R453, A\*V24\*\*\*:R413, R414, R415) resistance value correct? Check the resistor is opened
- 3) Is there no short or open around IC451 (A\*V18\*\*\*) or IC451, IC452 (A\*V24\*\*\*)?

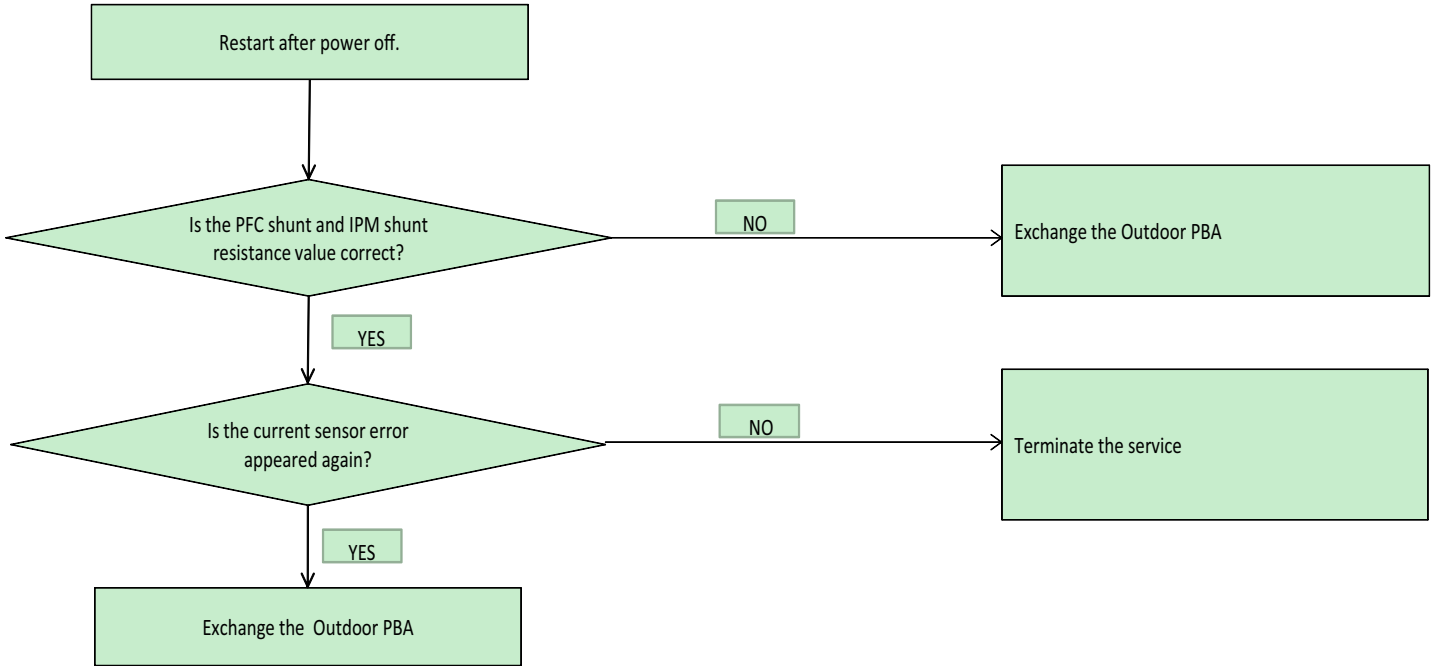

Heatsink sensor error/Heatsink over heat

Indoor display				Outdoor error
Outdoor display				Heatsink sensor error
				Heatsink over heat error

1. Checklist :

- 1) Are there screws assembly in PBA-heatsink?
- 2) Is the gap PBA-heatsink
- 3) Is the fan operation normal?
- 4) Is the cover assembly in control-box normal?

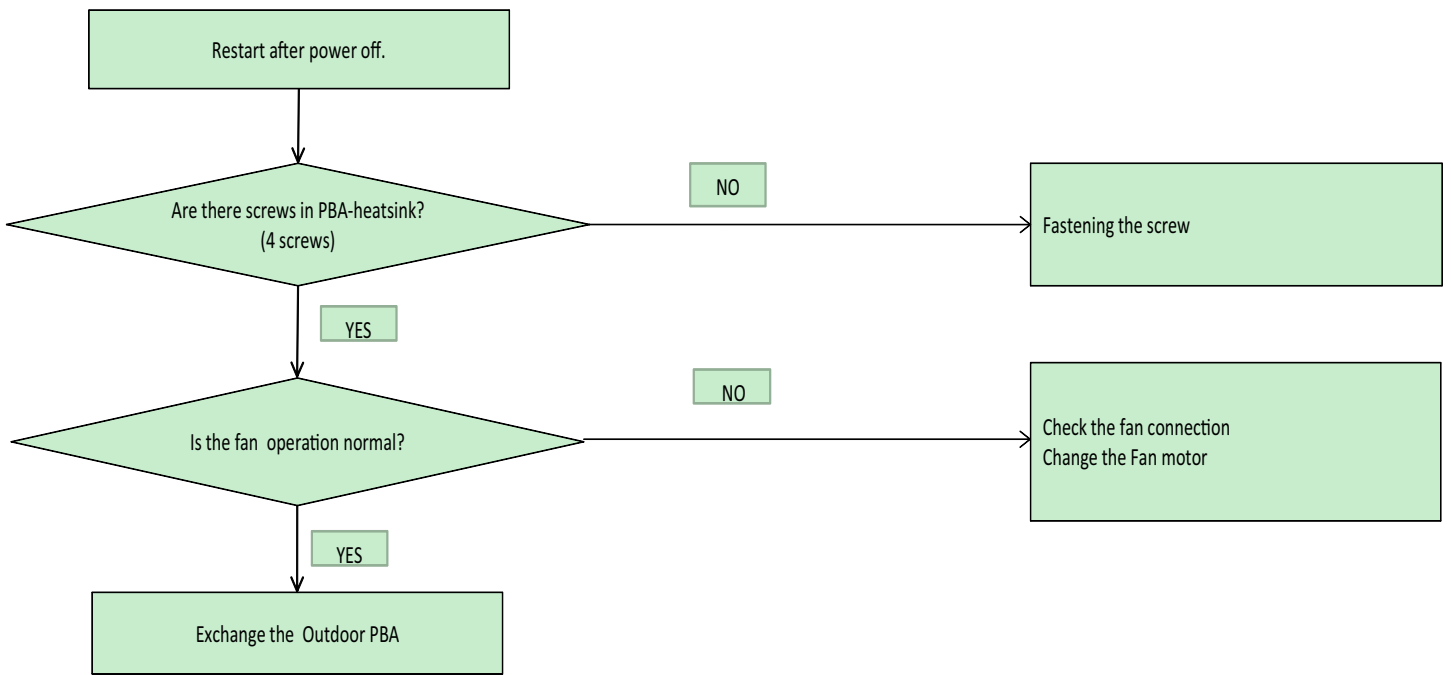

Comp Vlimit error/Comp current limit error

Indoor display  Outdoor error

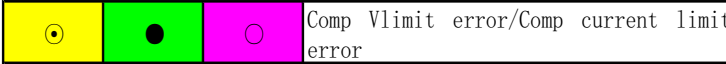
Outdoor display  Comp Vlimit error/Comp current limit error

1. Checklist :

- 1) Is the IPM Shunt (A\*V18\*\*\*:R451, R452, R453, A\*V24\*\*\*:R413, R414, R415) resistance value correct? Check the resistor is opened
- 2) Is the condition of surrounding temperature abnormal overload?
- 3) Is there any problem as like the temperature sensor separation or measurement value error?
- 4) Is the interphase resistance of compressor normal?

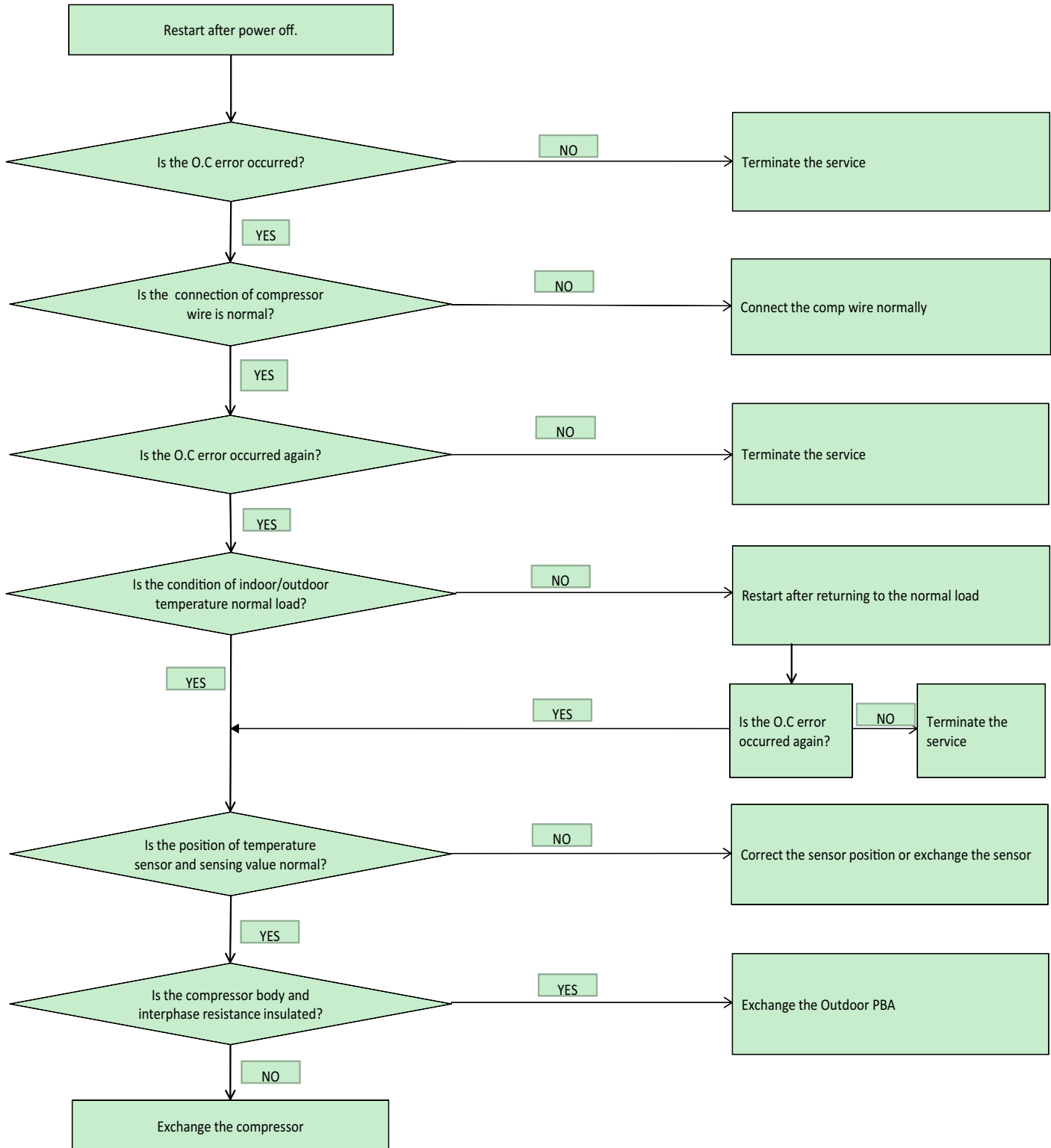

EEPROM error/OTP error

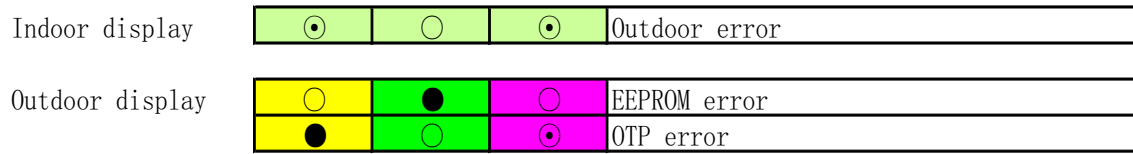

1. Checklist :

- 1) Is there a short around micom?
- 2) Is there a short around IC202 (A\*V18\*\*\*) or IC701 (A\*V24\*\*\*)?
- 3) Did you download or insert EEPROM IC, after changing outdoor PBA?

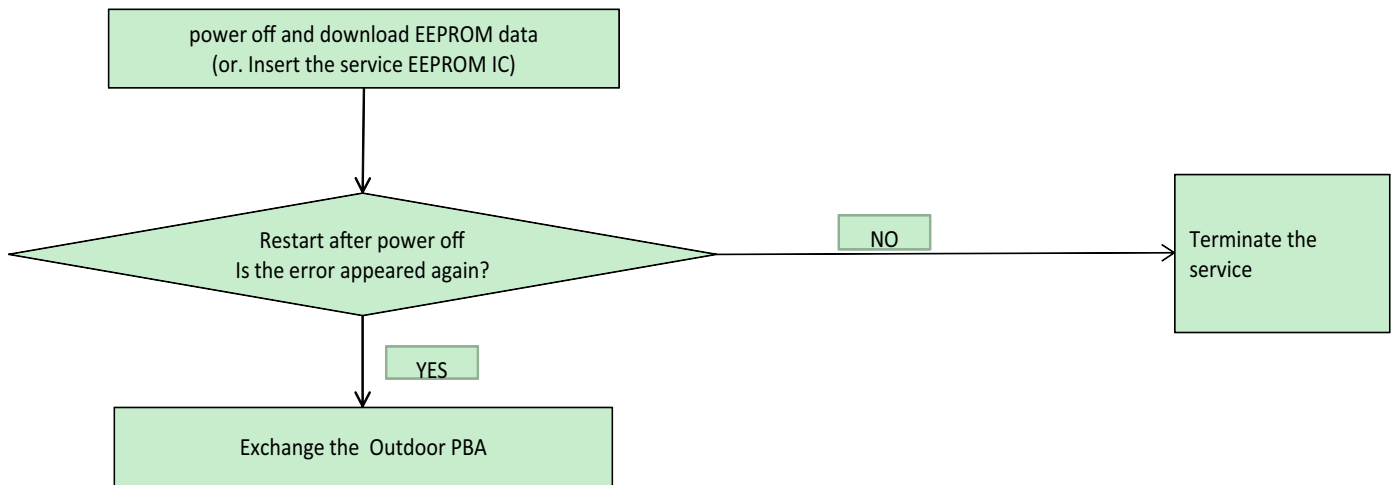



### AC zero cross signal error

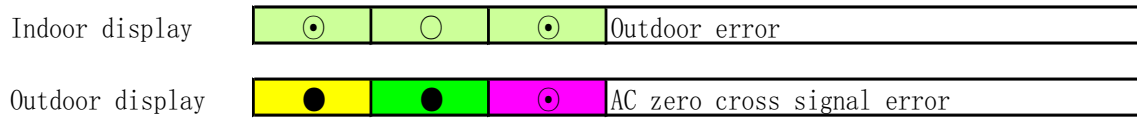

#### 1. Checklist :

- 1) Check the power condition at customer's house (Is there any power noise?)
- 2) Have been there power failure?

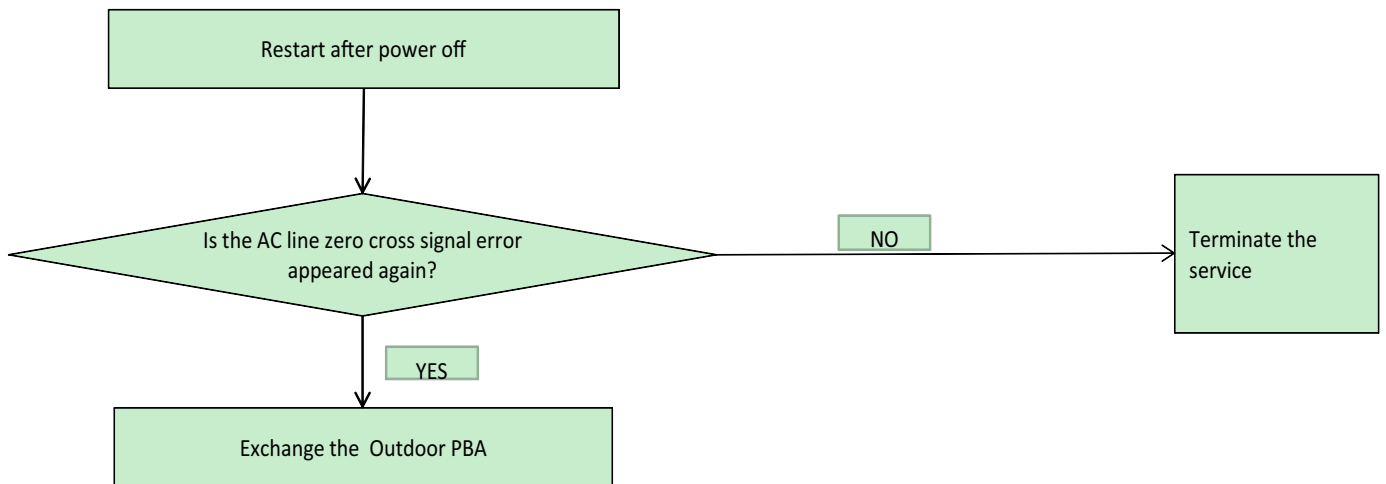

Operation condition secession error

Indoor display Outdoor error

Outdoor display AC zero cross signal error

1. Checklist :

1) Check the temperature around the outdoor unit.

2. Troubleshooting procedure

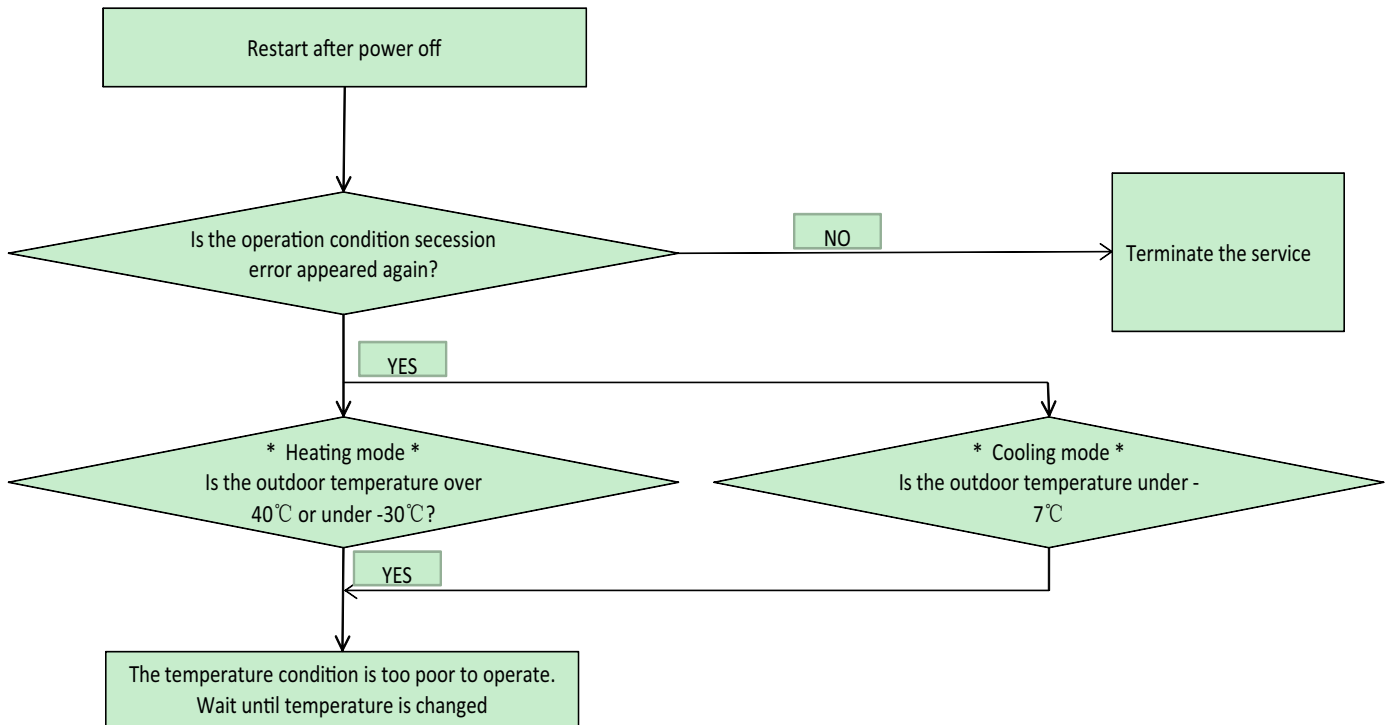

Capacity miss match error

Indoor display  Outdoor error

Outdoor display  Capacity miss match error

1. Checklist :

- 1) Check the Btu between indoor and outdoor unit
- 2) Check the indoor unit option and outdoor unit EEPROM data

2. Troubleshooting procedure

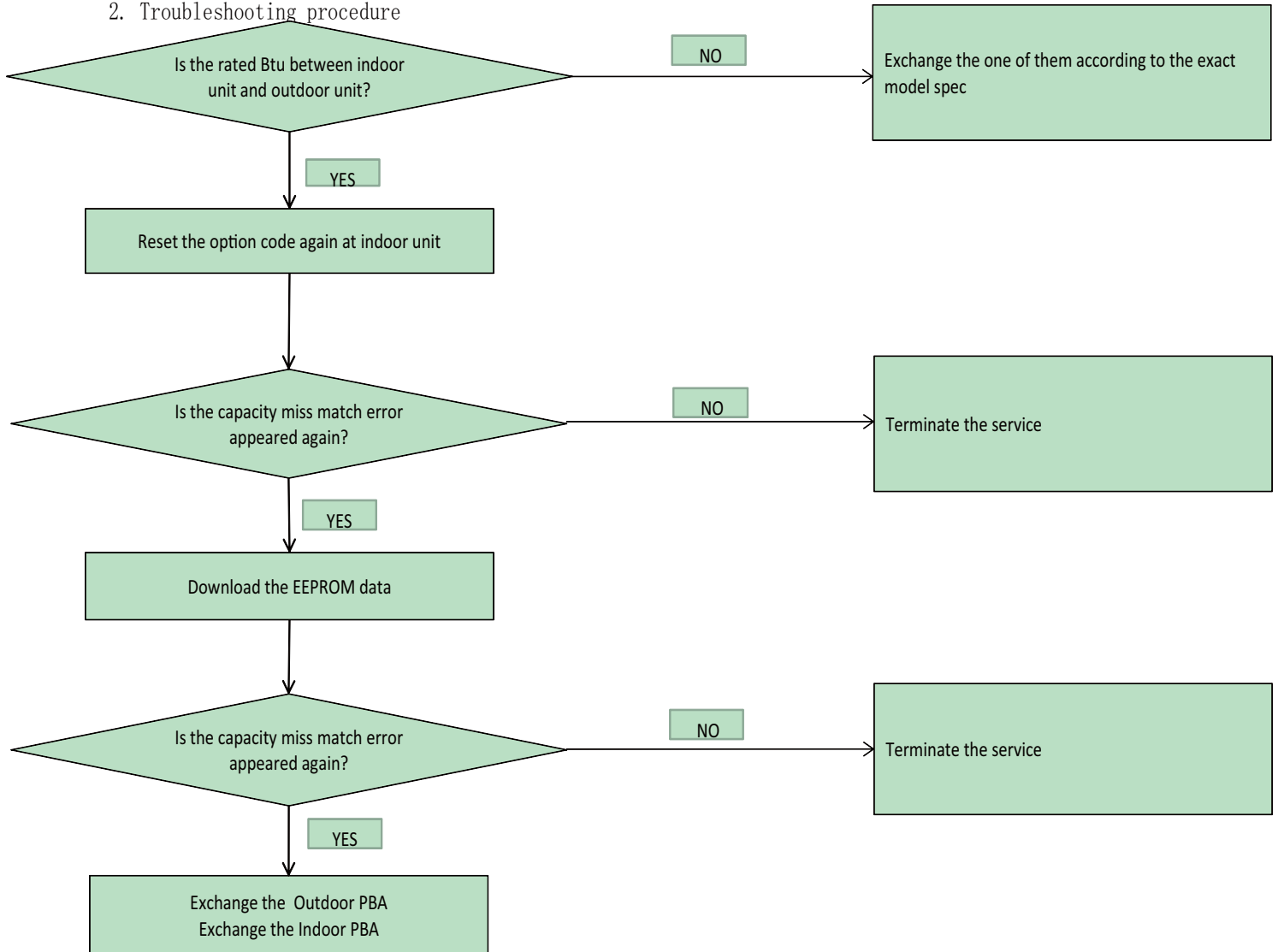

Gas leak error

Indoor display  Outdoor error

Outdoor display  Gas leak error

1. Checklist :

- 1) Is the position of indoor Eva\_in sensor normal?
- 2) Check the pipe crack
- 3) Check the EEV valve connection in Outdoor unit
- 4) Check the refrigerant was charged

2. Troubleshooting procedure

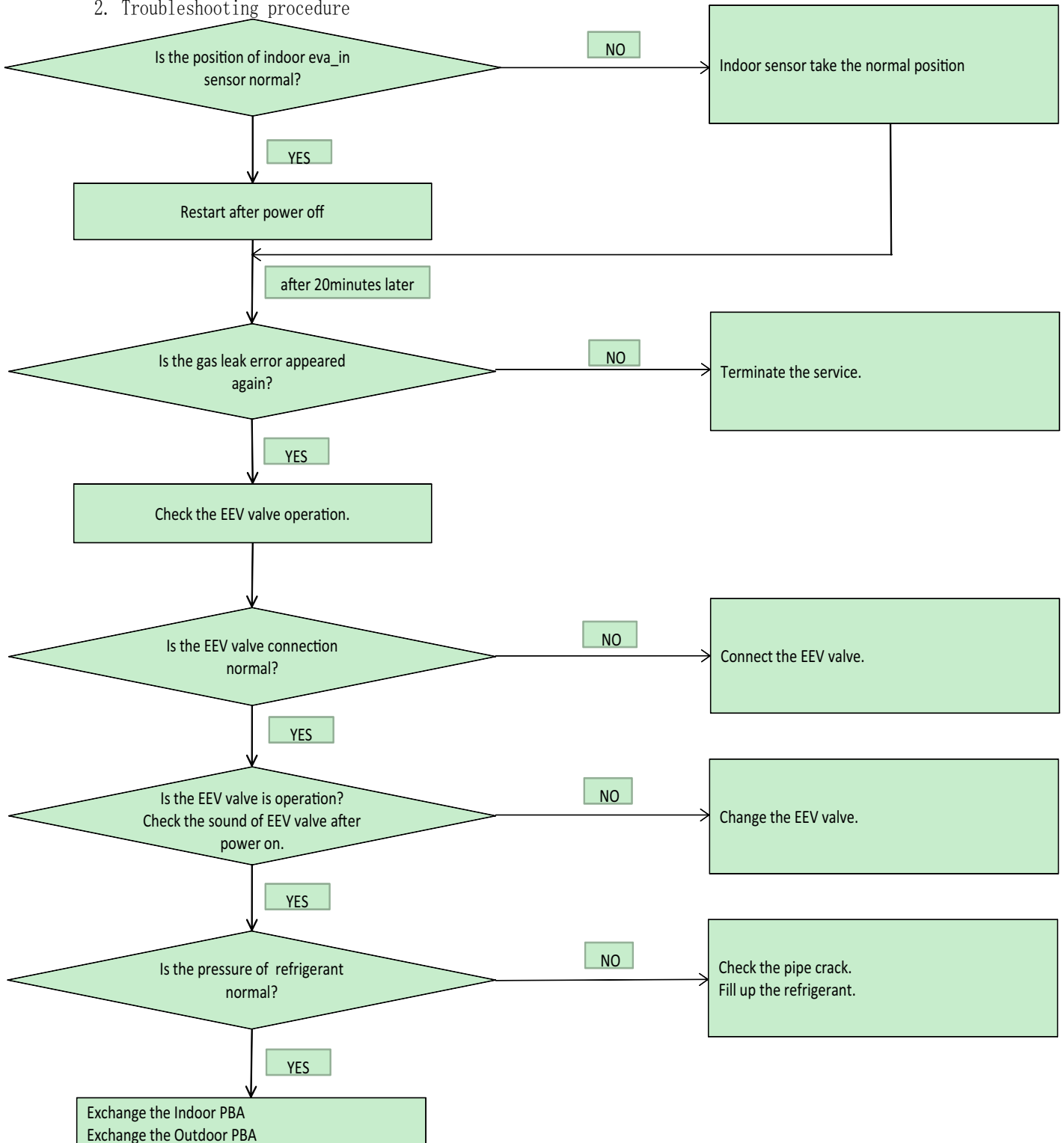

No power indoor (Initial Diagnosis) (Not displayed)

1. Checklist :

- 1) Is input power normal?
- 2) Is AC power linked correctly?
- 3) Is input voltage of DC\_link capacitor normal?
- 4) Is the voltage of DC regulator normal?

2. Troubleshooting procedure

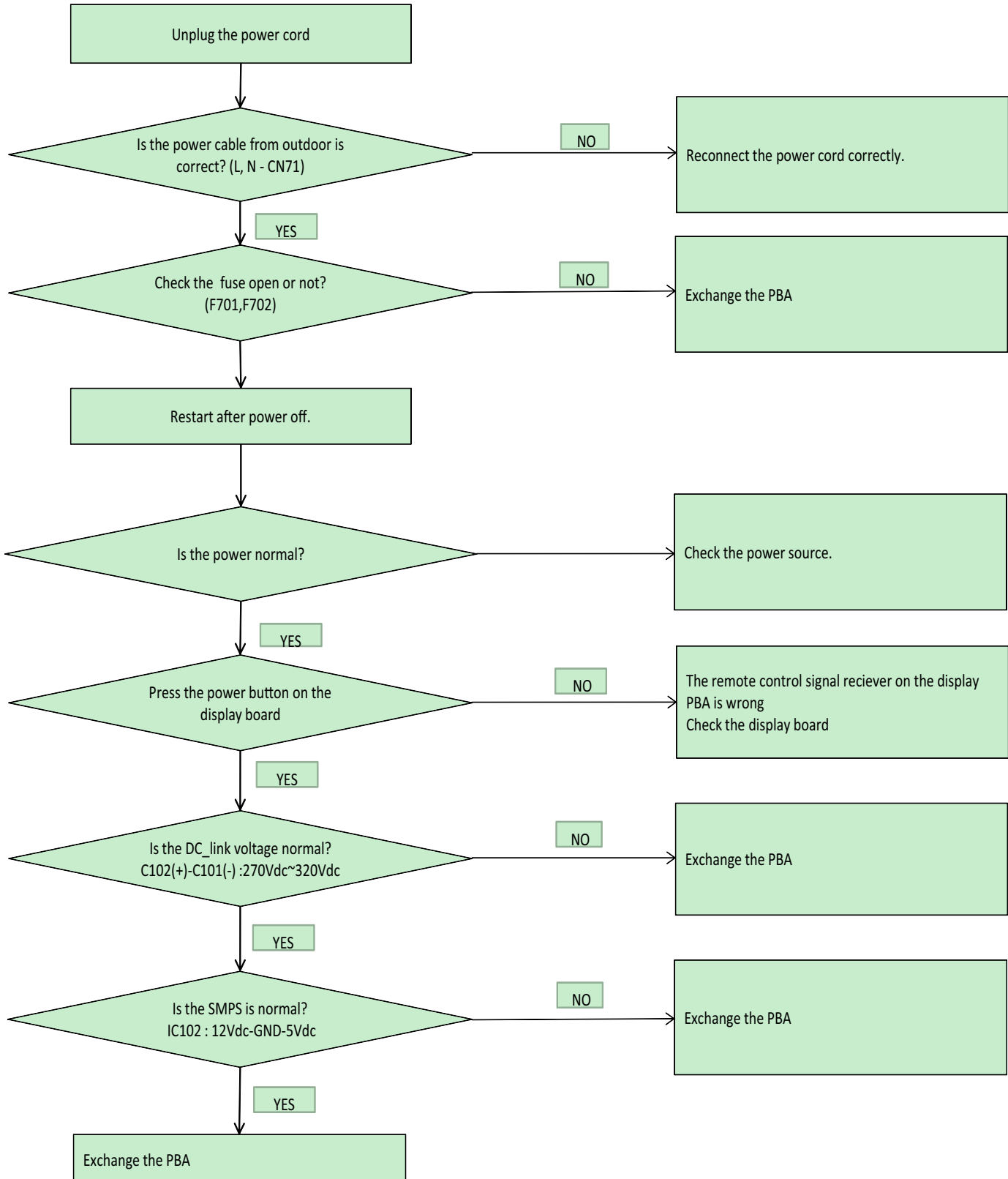

## 12-2 Outdoor Unit Error Display-AQX36VFUAGM/CV

If an error occurs during the operation, it is displayed on the outdoor unit PCB LED, both MAIN PCB and INVERTER PCB.

No.	Error Code	Meaning	Remarks
1	<b>E201</b>	Unit quantity miss matching between indoor and outdoor.	Check indoor quantity setting in outdoor (Refer to page 17.)
2	<b>E202</b>	Abnormal state, no communication between Indoor and Outdoor Main PCB	Check electrical connection and setting
3	<b>E203</b>	1min. Time out of communication error(Main $\times$ Inverter)	Check electrical connection and setting
4	<b>E221</b>	Outdoor temp sensor error	Check Outdoor sensor Open/Short
5	<b>E231</b>	Cond. temp sensor error	Check Cond. sensor Open/Short
6	<b>E251</b>	Discharge temp sensor error	Check Discharge sensor Open/Short
7	<b>E320</b>	OLP Sensor Error	Check OLP sensor Open/Short
8	<b>E403</b>	Detection of Outdoor Freezing when Comp. Stop	Check Outdoor Cond.
9	<b>E404</b>	Protection of Outdoor Overload when Comp. Stop	Check Comp. when it start
10	<b>E416</b>	Discharge temperature of a compressor in an outdoor unit is overheated.	
11	<b>E440</b>	Heating operation is not available since the outdoor air temperature is over 30°C.	Heating
	<b>E441</b>	Cooling operation is not available since the outdoor air temperature is lower than -5°C.	Cooling
12	<b>E458</b>	Outdoor unit BLDC Fan 1 or Fan 2 error	FAN1 error
	<b>E475</b>		FAN2 error
13	<b>E461</b>	Comp. Starting error	
14	<b>E462</b>	Primary Current Trip error	
15	<b>E463</b>	Over current trip / PFC over current error	Check OLP sensor
16	<b>E464</b>	IPM(IGBT Module) Over Current(O.C)	
17	<b>E465</b>	Comp. Over load error	
18	<b>E466</b>	DC-Link voltage under/over error	Check AC Power or DC_Link voltage
19	<b>E467</b>	Comp. wire missing error	Check Comp. wire
20	<b>E468</b>	Current sensor error	Check Outdoor Inverter PBA
21	<b>E471</b>	Outdoor EEPROM error	Check Outdoor EEPROM date
22	<b>E474</b>	IPM(IGBT Module) or PFCM Temperature sensor Error	Check Outdoor Inverter PBA
23	<b>E484</b>	PFC Overload Error	Check Outdoor Inverter PBA
24	<b>E500</b>	IPM is over heated.	Check Outdoor Inverter PBA
25	<b>E554</b>	GAS Leak error	Check indoor and outdoor unit model
26	<b>E556</b>	Capacity miss match between indoor and outdoor	Check indoor and outdoor unit model

## 12-2 Fault Diagnosis by Symptom

### 12-2-1 No Power(completely dead) - Initial diagnosis

1. Checklist:
  - 1) Is Power source voltage normal?
  - 2) Is AC power linked correctly?( miss-wiring, wire detaching etc. )
  - 3) Is any LED on the MAIN PCB of Outdoor unit lit?
  - 4) Is terminal voltage for indoor unit normal?(230Vac nominal)
  - 5) Is Wired remote controller installed correctly?
2. Troubleshooting procedure

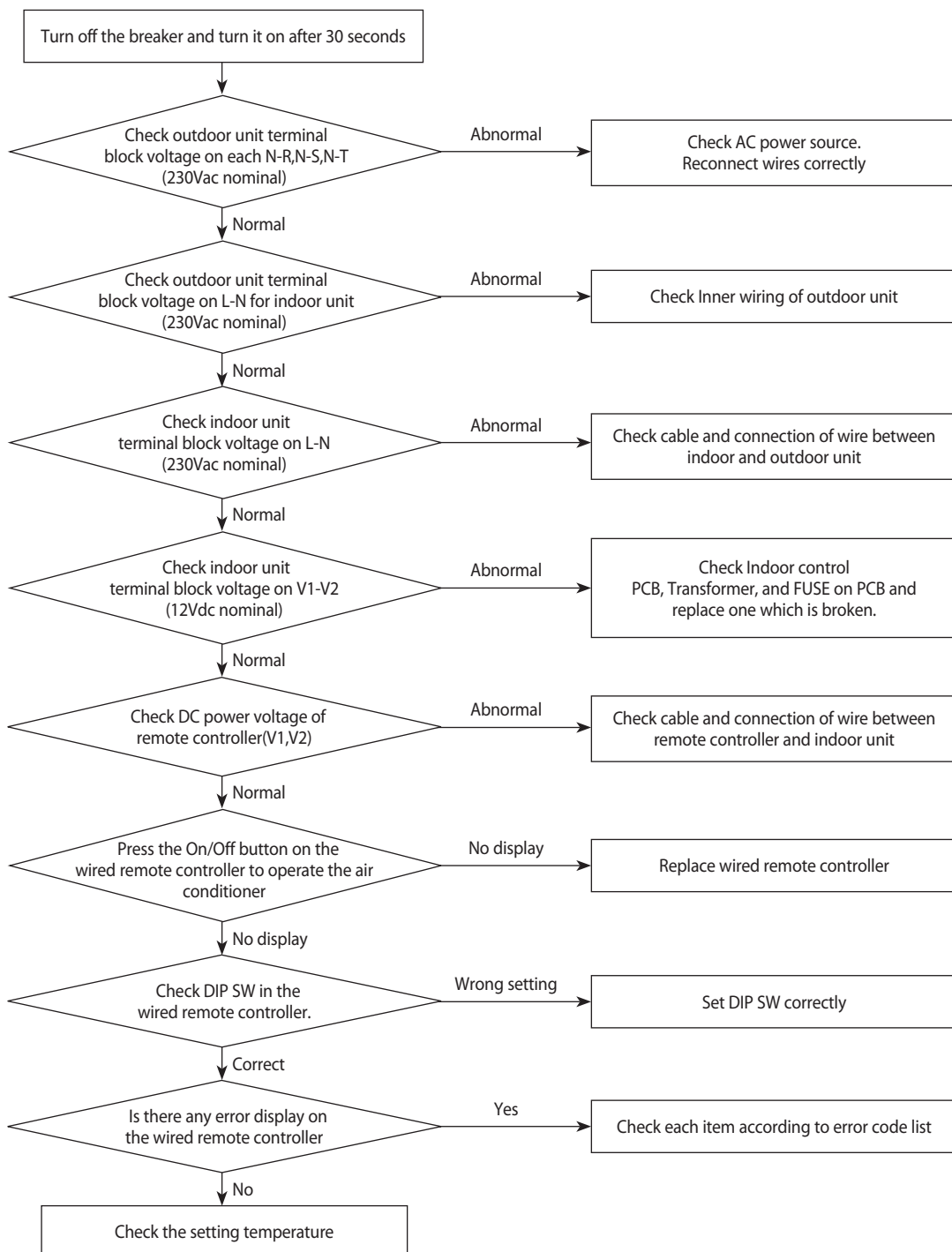

## 12-2-2 The Outdoor unit Power Supply error

1. Checklist:
  - 1) Are the input power voltage and power connection correct?
  - 2) Is there any Fuse Short of the indoor or outdoor unit?
  - 3) Is any LED lit on both MAIN PCB and INVERTER PCB?
  - 4) Are Reactor wires of the outdoor unit connected correctly?

### 2. Troubleshooting procedure

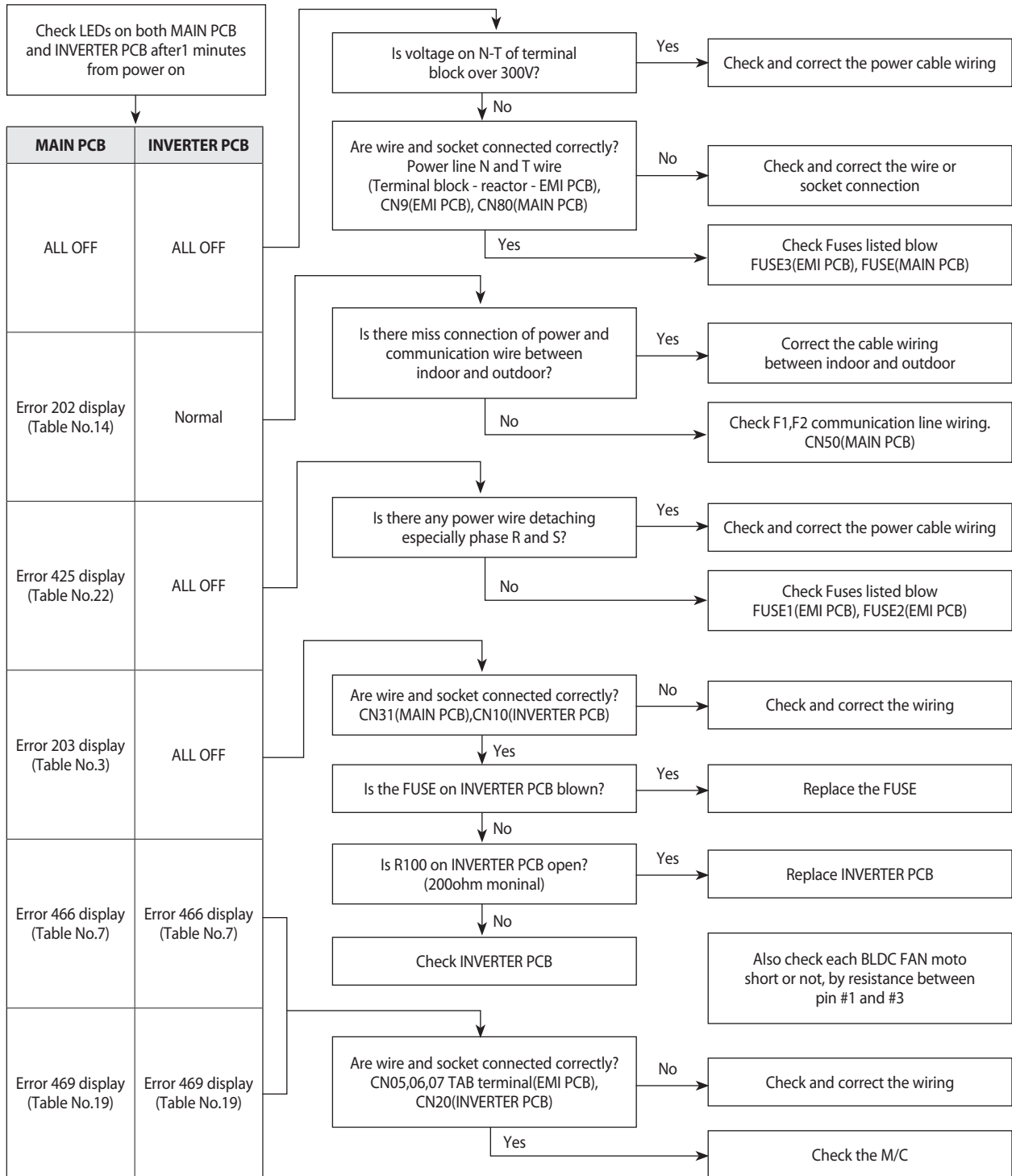



## 12-2-3 The Outdoor unit Fan error

1. Checklist:
  - 1) Are the input power voltage and power connection correct?
  - 2) Is the motor wire connected to the outdoor PCB correctly?
  - 3) Is there no obstacle at the surrounding of motor and propeller?
  - 4) Does the driver in the motor case broken?
2. Troubleshooting procedure

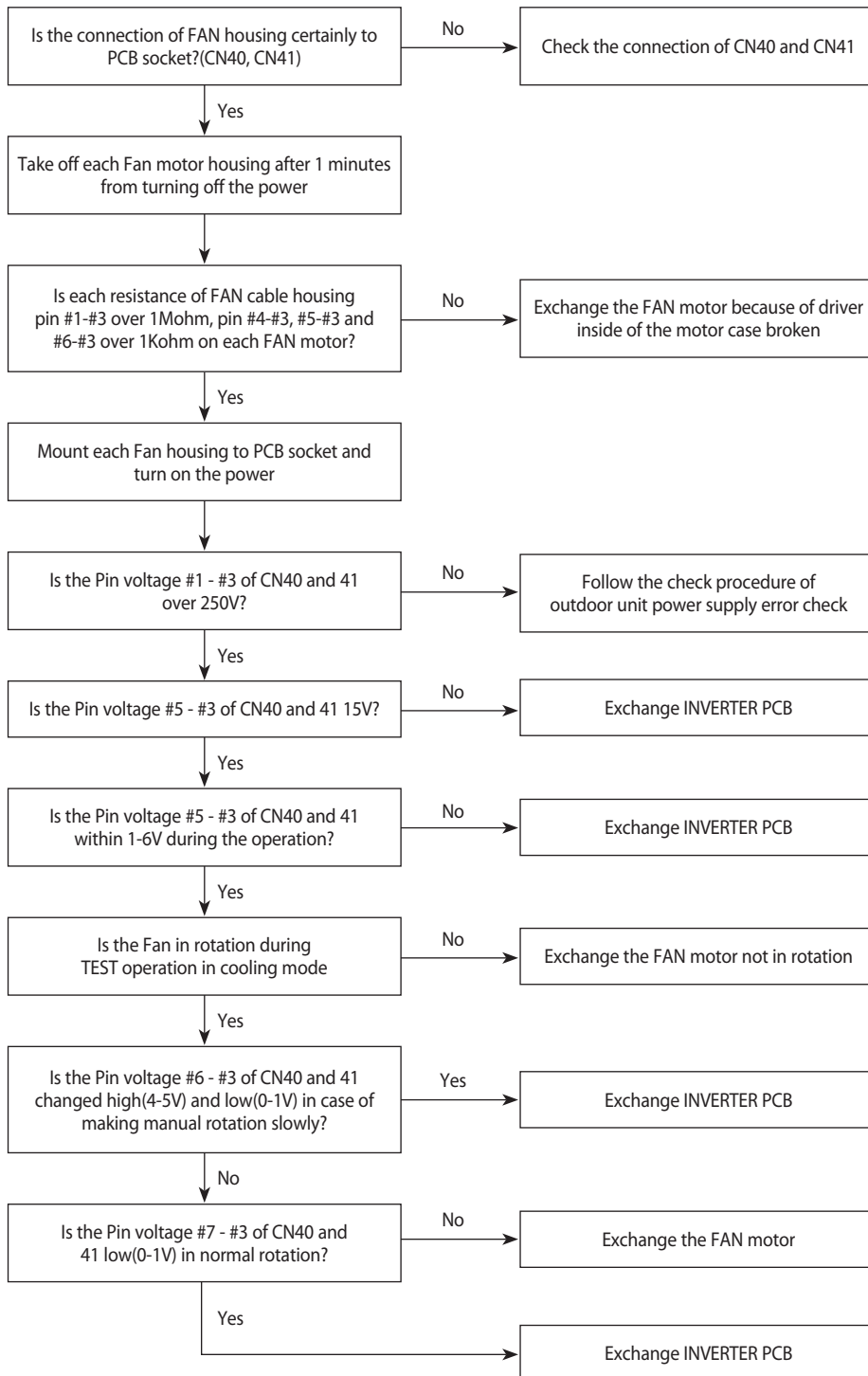

# TEST operation #  
press K900 button on the MAIN PCB after power on.

- once : cooling mode  
- twice in a second : heating mode

## 12-2-4 Total current trip error

### 1. Checklist :

- 1) Is the input power voltage proper?
- 2) Is the refrigerant charged properly?
- 3) Does the compressor rotate normally?(Reverse rotation, Locking etc.)
- 4) Does the outdoor fan operate normally?(Fan propeller loss, Motor error ect.)
- 5) Is the installation condition of outdoor unit good?(Piping, Space etc.)
- 6) Is there no ventilation obstruction at the surrounding of outdoor unit?(Outdoor unit cover, Fan front obstruction etc.)
- 7) Is there no ventilation obstruction at the surrounding of indoor unit?(Overload condition in heating mode)

### 2. Troubleshooting procedure

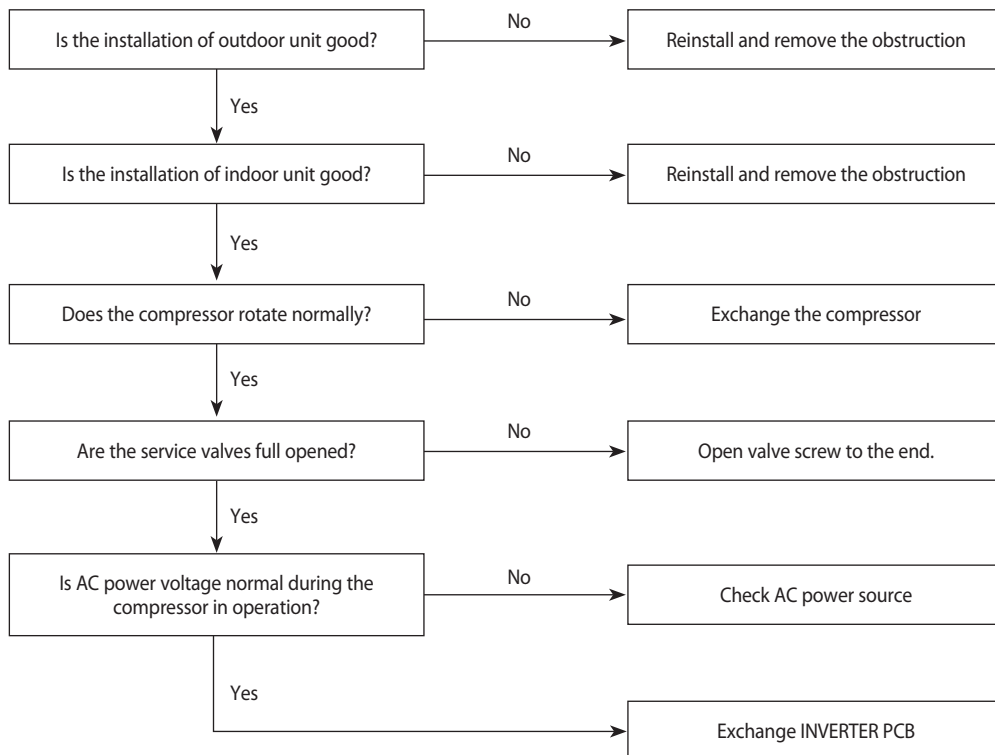

## 12-2-5 In case of heating at the cooling mode or cooling at the heating mode

### 1. Troubleshooting procedure

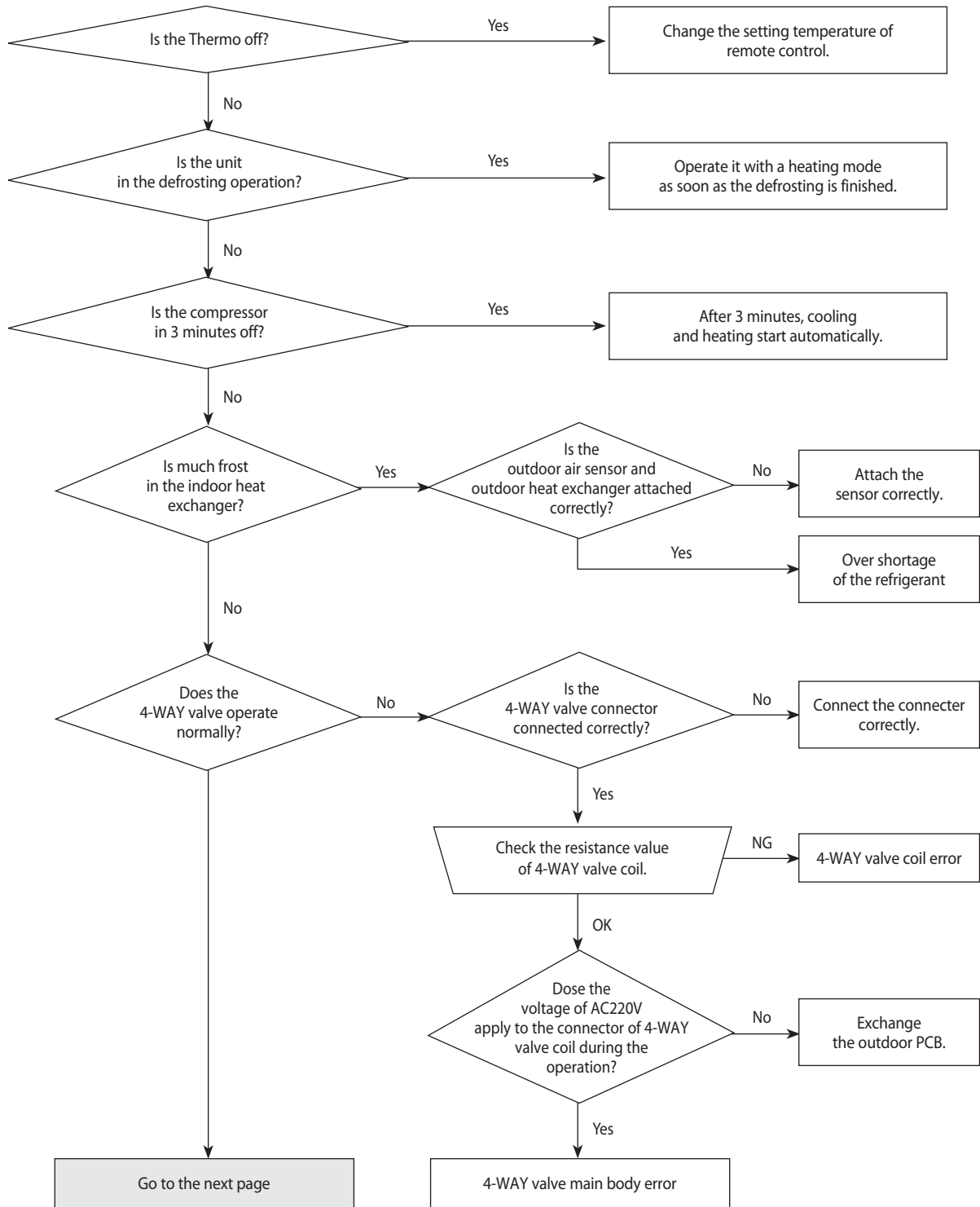

**In case of heating at the cooling mode or cooling at the heating mode(cont.)**

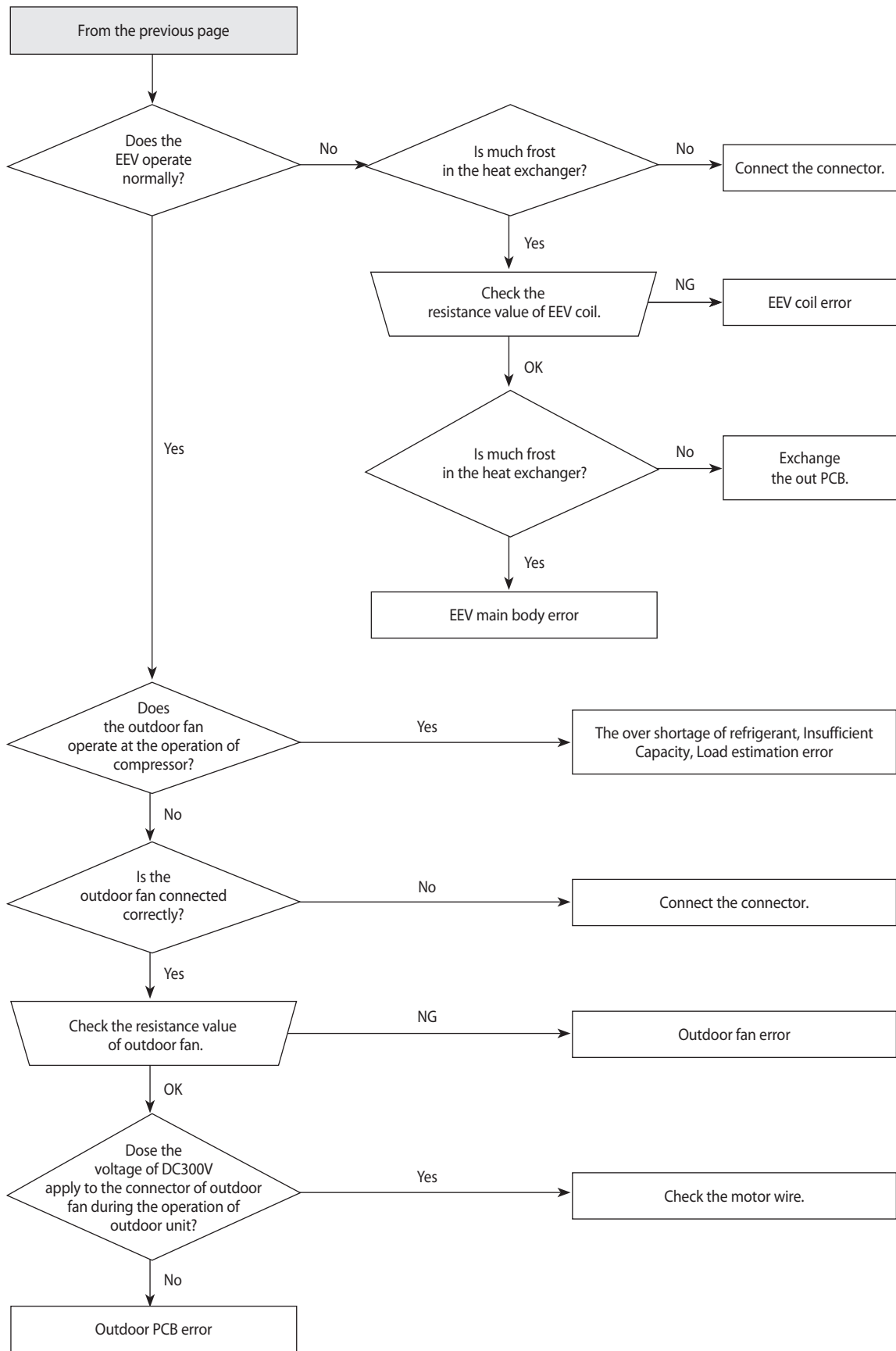

## 12-2-6 Outdoor temperature sensor error

### 1. Checklist :

- 1) Is the sensor connector connected correctly?
- 2) Is the sensor placed correctly?
- 3) Does the both terminal of sensor satisfy the resistance value in accordance with temperature?
- 4) Is the resistance value of sensor connection pull\_up correct?

### 2. Troubleshooting procedure

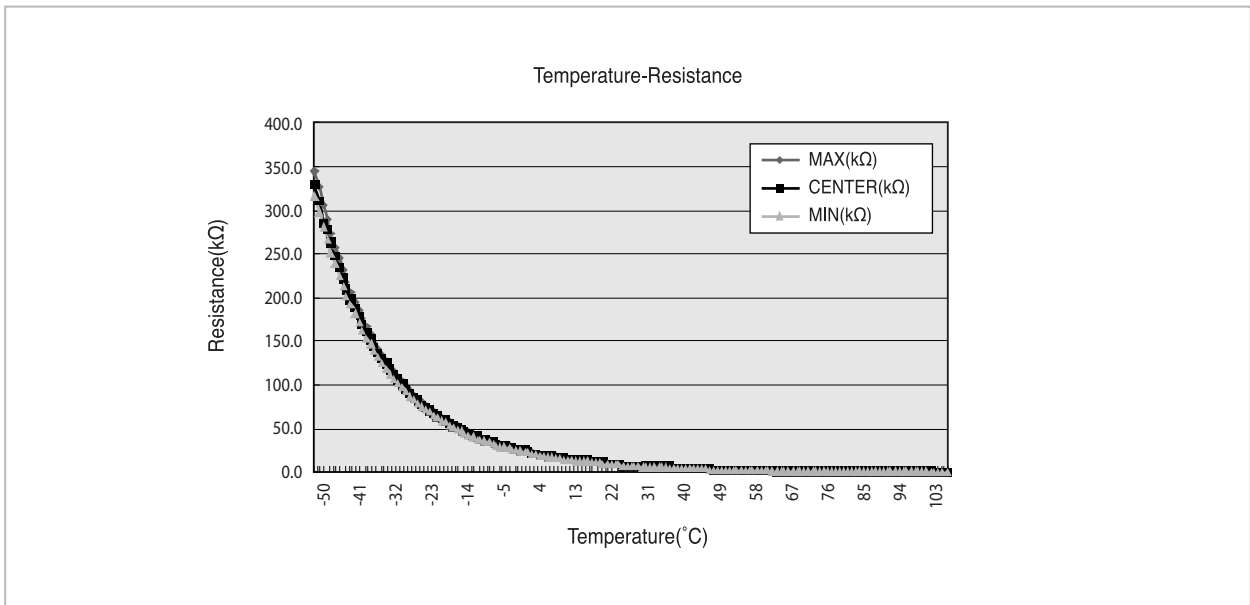
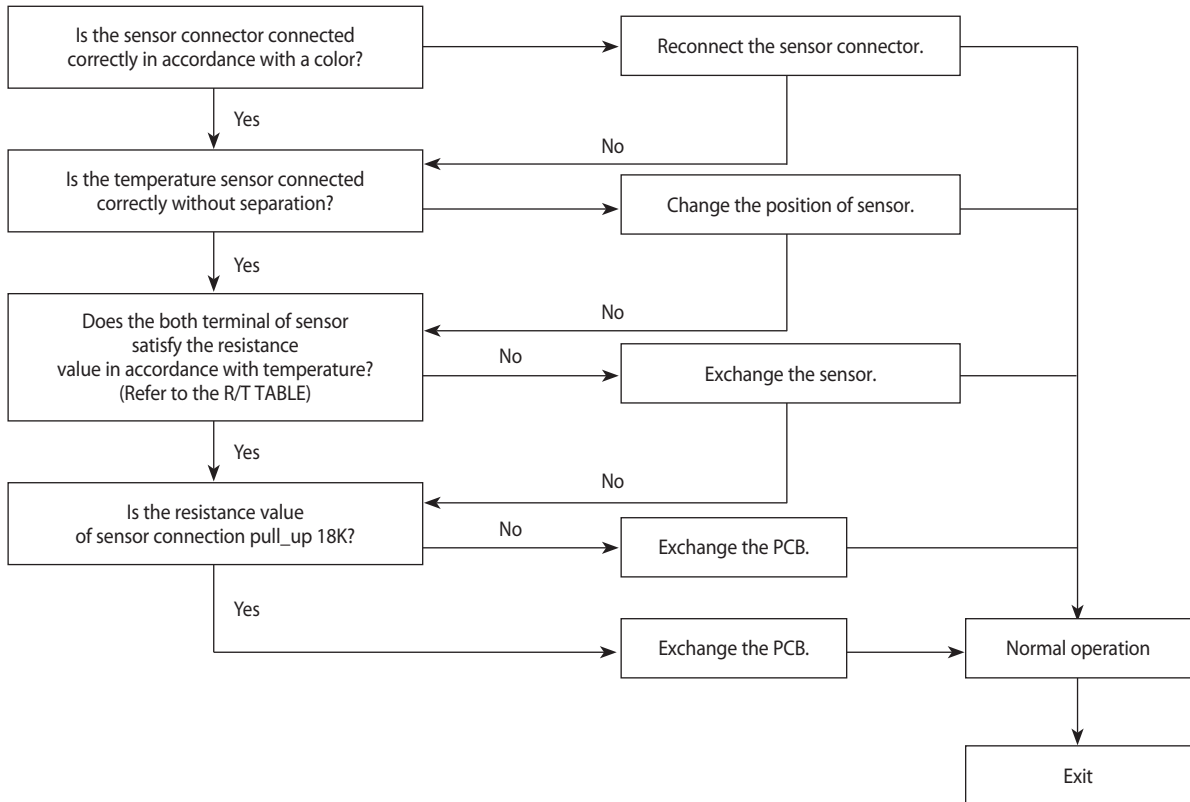

## 12- 2-7 Discharge temperature sensor error

### 1. Checklist :

- 1) Is the sensor connector connected correctly?
- 2) Is the sensor placed correctly?
- 3) Does the both terminal of sensor satisfy the resistance value in accordance with temperature?
- 4) Is the resistance value of sensor connection pull\_up correct?

### 2. Troubleshooting procedure

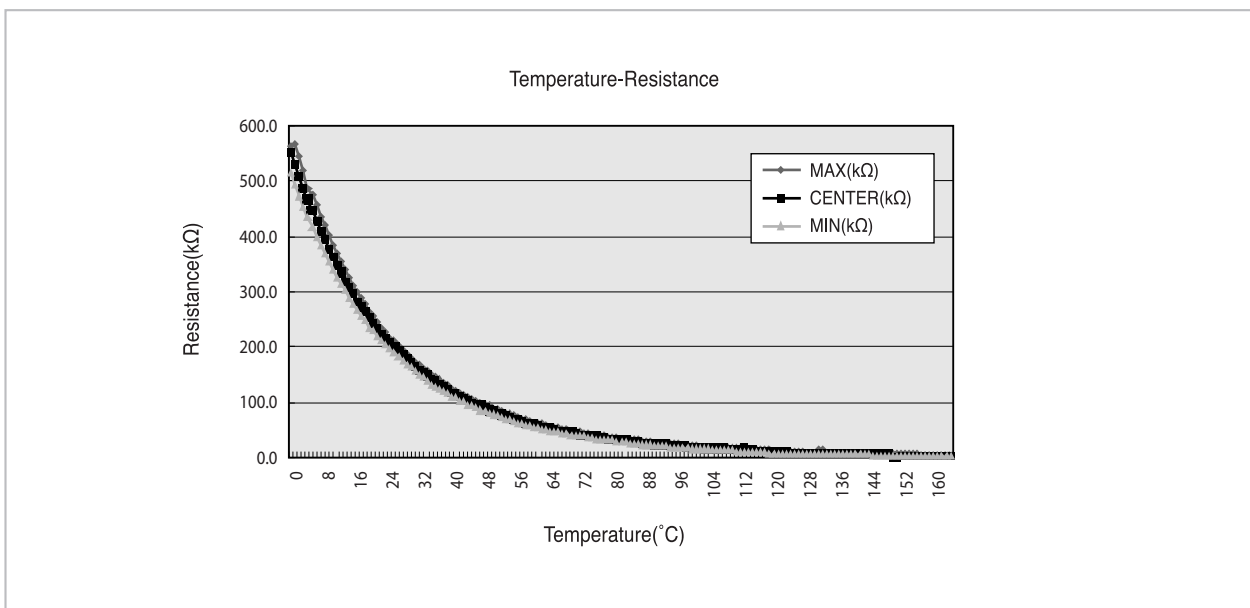
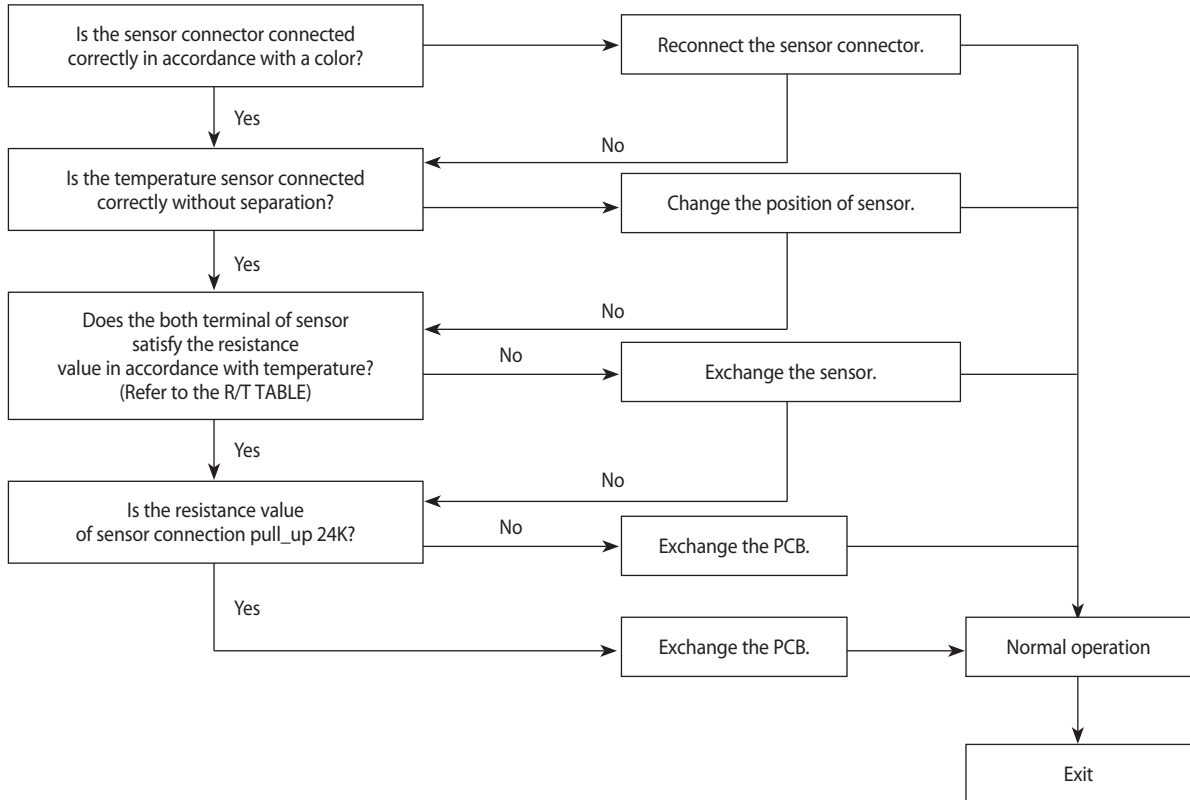

## 12-2-8 Coil temperature sensor error

### 1. Checklist :

- 1) Is the sensor connector connected correctly?
- 2) Is the sensor placed correctly?
- 3) Does the both terminal of sensor satisfy the resistance value in accordance with temperature?
- 4) Is the resistance value of sensor connection pull\_up correct?

### 2. Troubleshooting procedure

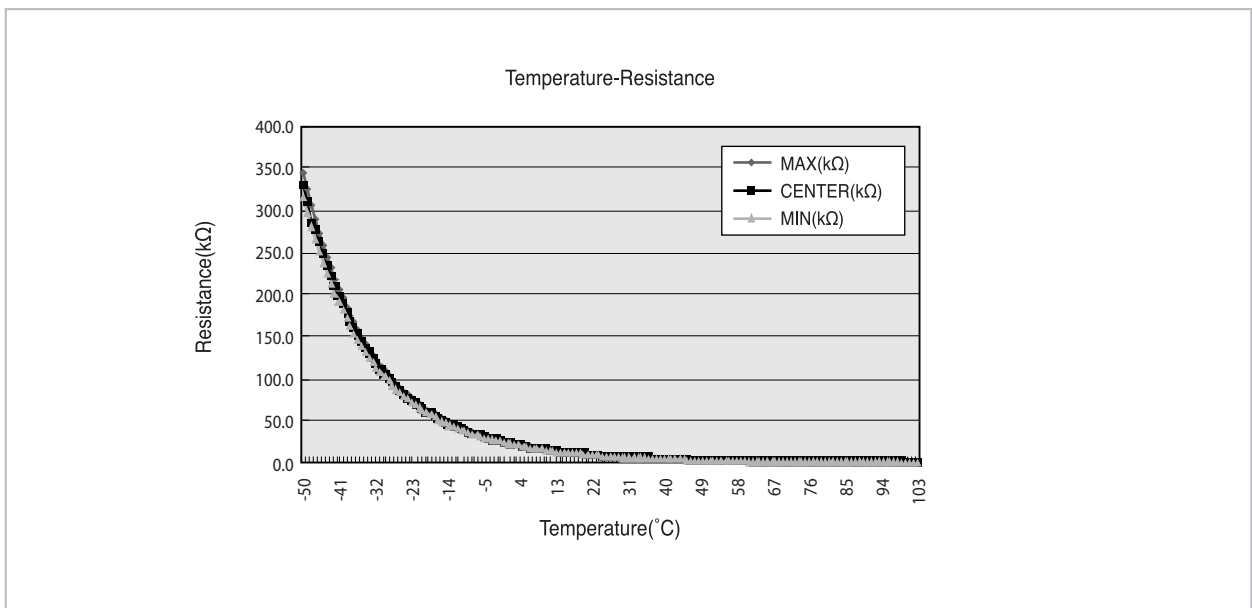
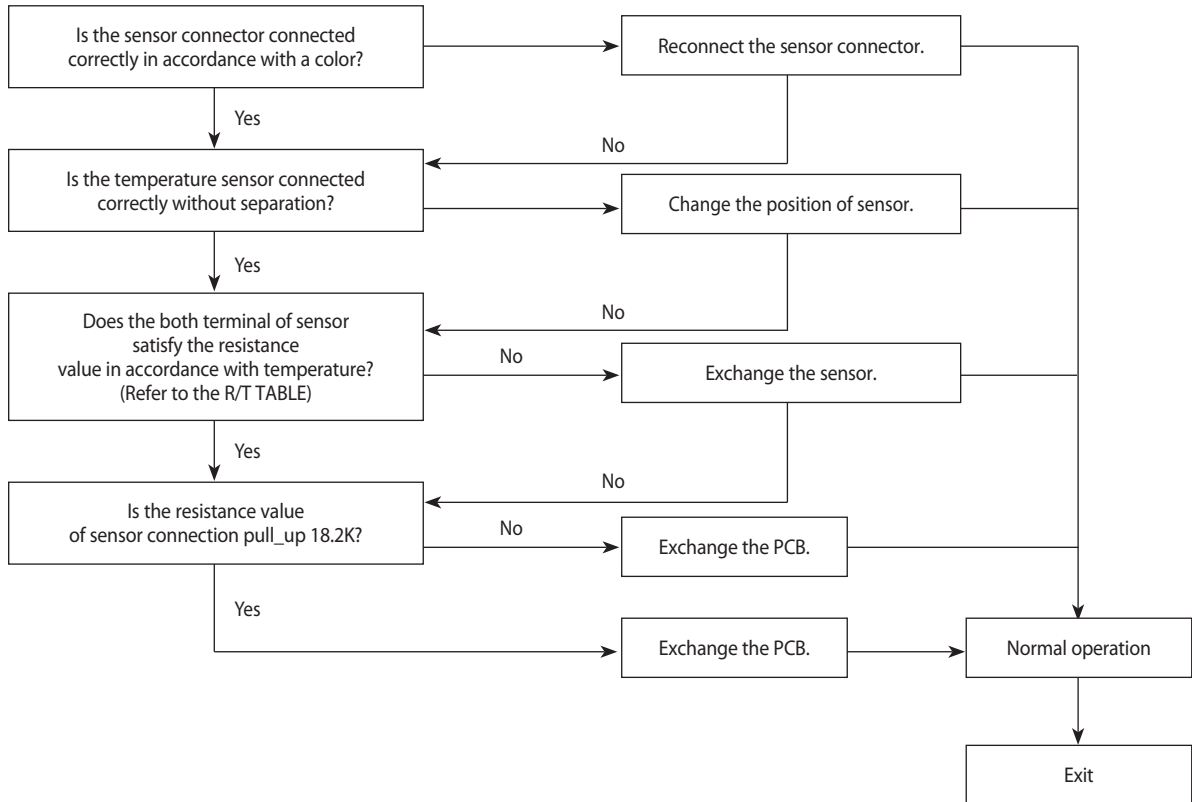

## 12- 2-9 Fan error

### 1. Checklist :

- 1) Isn't the fan locked?
- 2) Is the sensor placed correctly?
- 3) Does the both terminal of sensor satisfy the resistance value in accordance with temperature?
- 4) Is the resistance value of sensor connection pull\_up correct?

### 2. Troubleshooting procedure

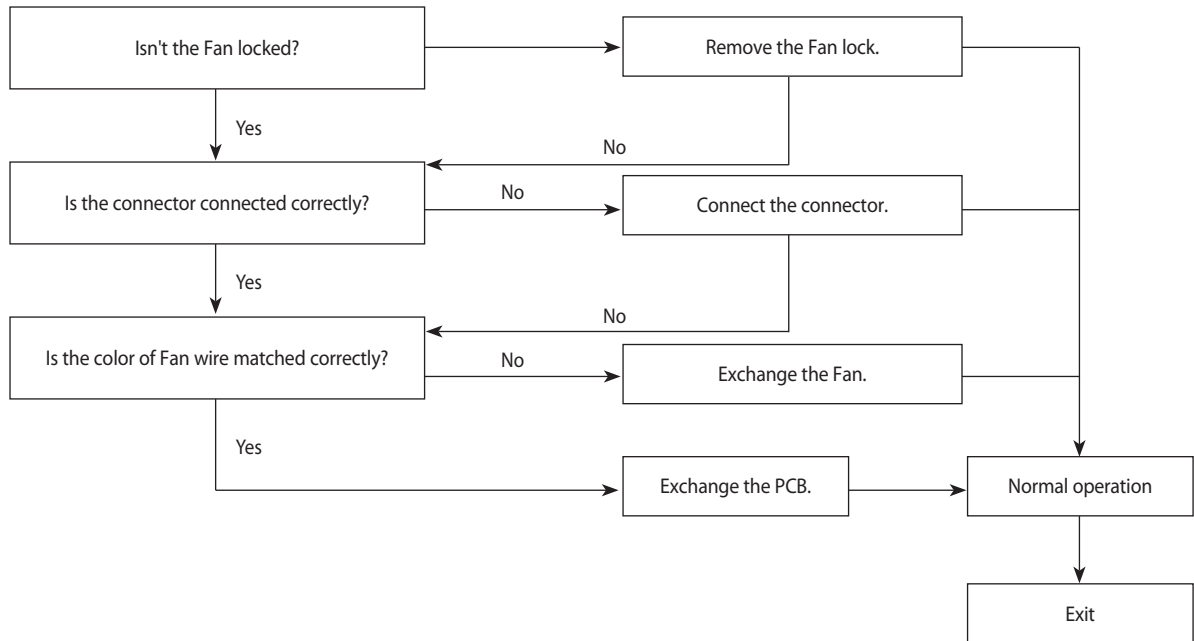



## 12-2-10 DC-Link voltage sensor error

1. Checklist :

- 1) Is the connection of R, S, T power wire normal?
- 2) Are Relay RY21 and R200 on the INVERTER PCB mounted normally?

2. Troubleshooting procedure

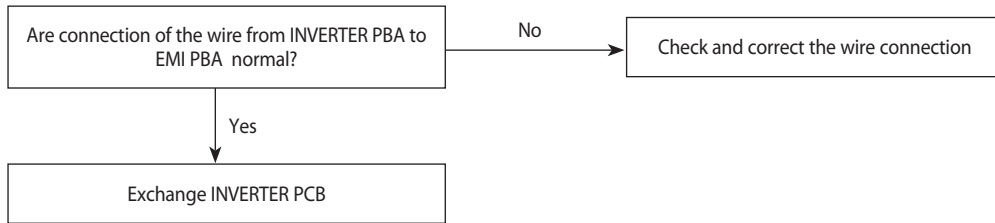

## 12-2-11 O.C.(Over Current) error

1. Checklist :
  - 1) Is the refrigerant charged properly?
  - 2) Does the compressor rotate normally?(Reverse rotation, Locking etc.)
  - 3) Is connection of compressor wire normal?
  - 4) Is compressor motor normal?(Insulation, Coil resistance etc.)
  - 5) Does a temporary cycle overload condition happened?

### 2. Troubleshooting procedure

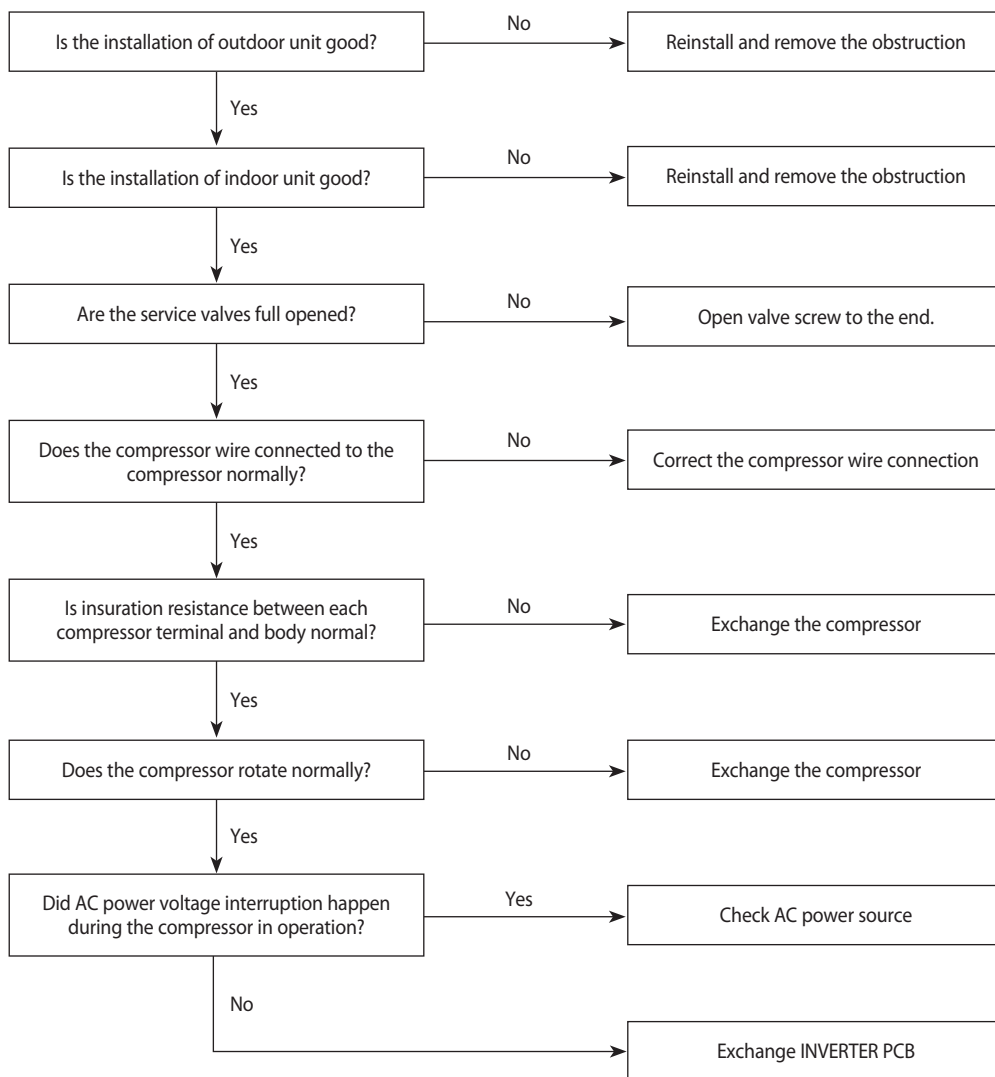

## 12-2-12 Communication error

### 1. Checklist :

- 1) Is the communication cable between the indoor unit and outdoor unit connected correctly?
- 2) Isn't the power cable and communication cable wiring error?

### 2. Troubleshooting procedure

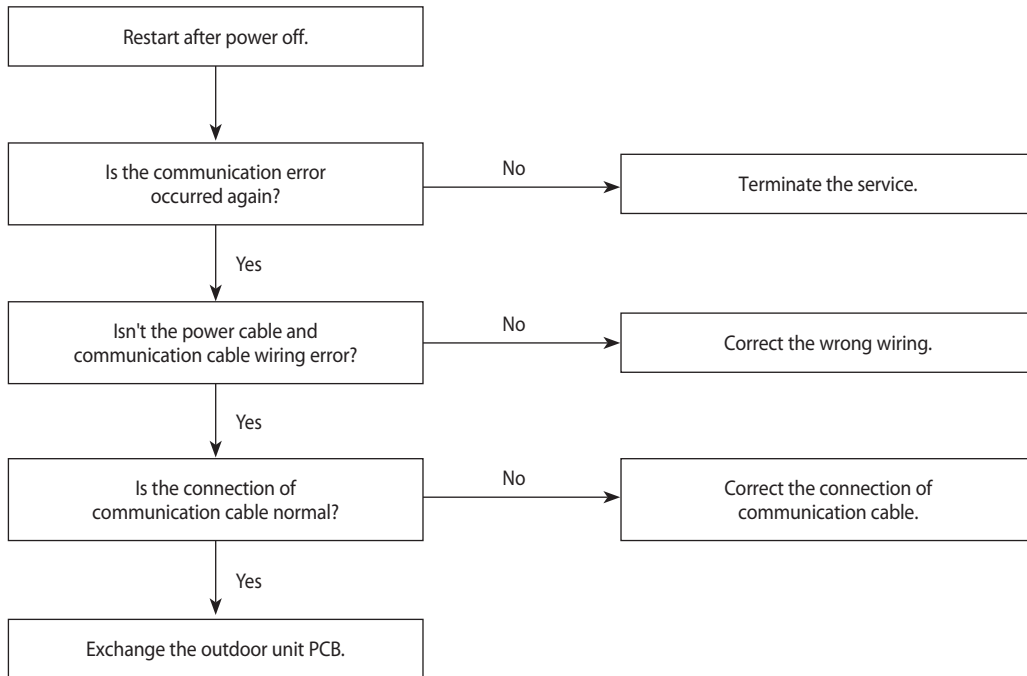

## 12-2-13 Compressor start error

1. Checklist :
  - 1) Is the connection of cable for the compressor and power?
  - 2) Is the interphase resistance of compressor normal?
2. Troubleshooting procedure

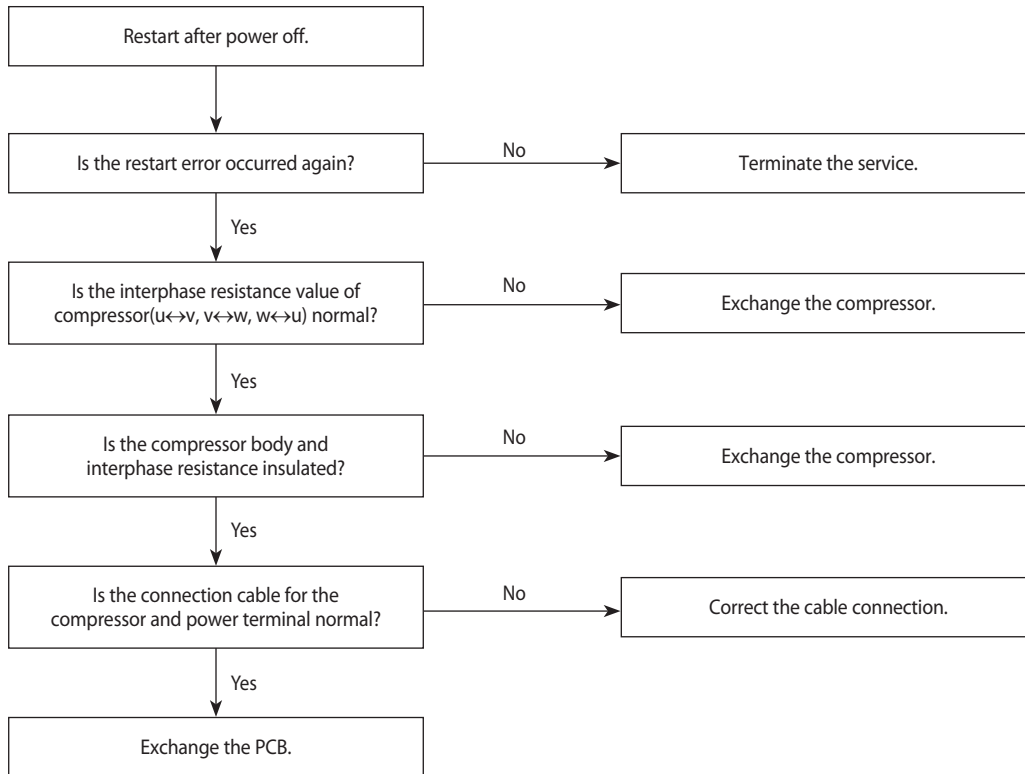

## 12-2-14 Compressor lock error

1. Checklist :
  - 1) Is the connection of cable for the compressor and power?
  - 2) Is the interphase resistance of compressor normal?
2. Troubleshooting procedure

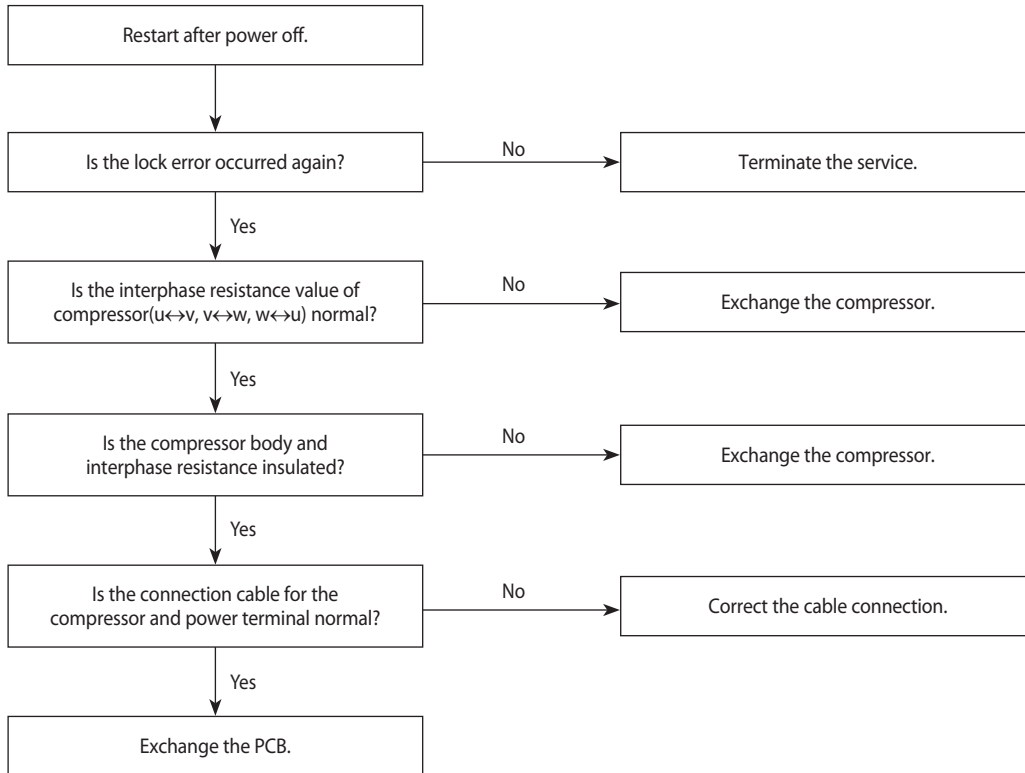

## 12-2-15 DC Link Over voltage/ Low voltage error

### 1. Checklist :

- 1) Is the power voltage normal?(Lightning, Power interruption etc.)
- 2) Is AC Power cable connection normal?(Detaching the wire)

### 2. Troubleshooting procedure

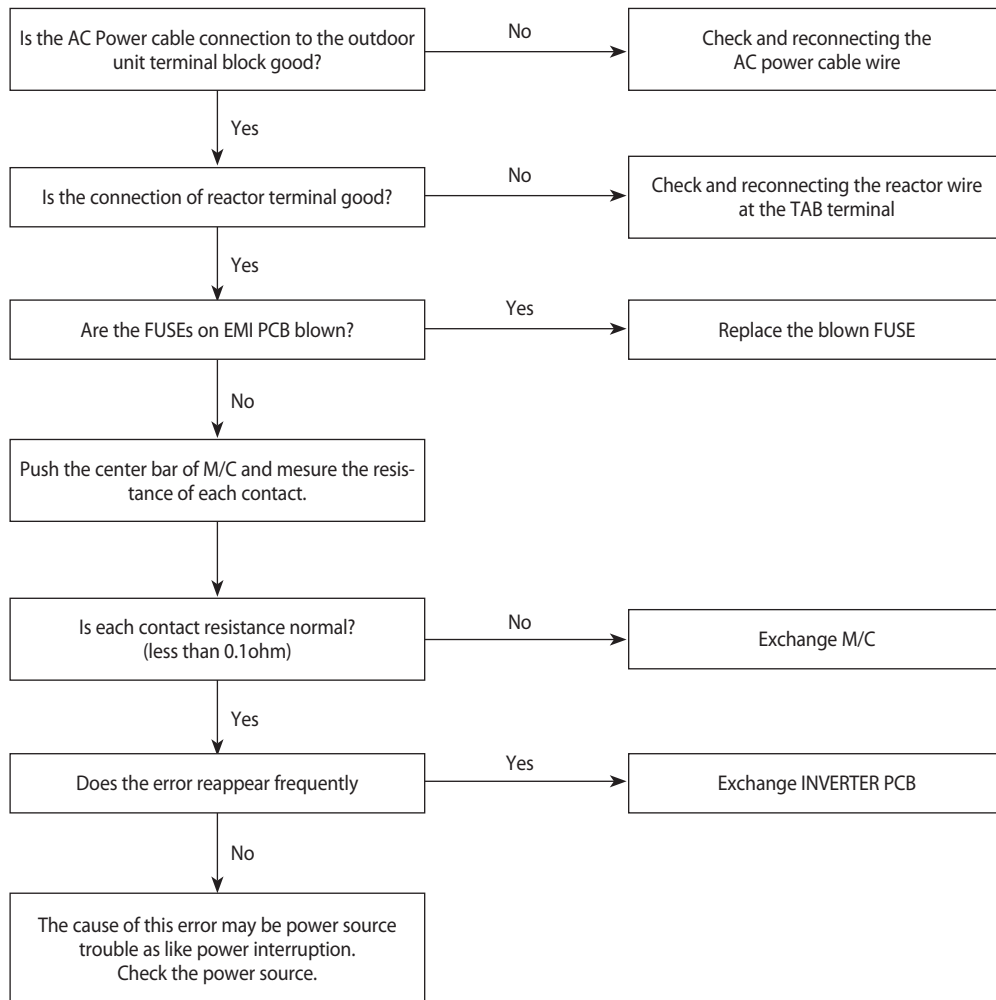

## 12-2-16 The others

### 1. Capacity miss match

- Check again the indoor unit option code.

### 12-3-1 Pre-inspection Notices

1. Check if you pulled out the AC power plug when you eliminate the PCB or front panel
2. Don't hold the PCB side not impose excessive force on it to eliminate the PCB
3. Don't pull the lead wire but hold the whole housing to connect or disconnect a connector to the PCB
4. In case of outdoor PCB disassembly, check first the complete discharge of condenser after 1 minute power off

### 12-3-2 Inspection procedure

1. Check connector connection and peeling of PCB or bronze coating pattern when you think the PCB is broken
2. The PCB is composed of 3 parts
  - Indoor Main part : MICOM and surrounding circuit, relay, fan motor sensing and driving circuit, temperature sensing circuit power circuit of SMPS, buzzer circuit. Communication circuit
  - Display part : LED lamp, Switch, Remote-control module
  - Outdoor Main part : MICOM and surround circuit, fan motor sensing and driving circuit, compressor driving circuit power circuit of SMPS, PFC control circuit, 4way circuit, communication circuit, OPTION (EEV control circuit, temperature sensing circuit)

### 12-3-3 Indoor detailed inspection procedure

No	procedure	Inspection Method	Cause
1	Plug out and pull the PCB out of the control box Check the PCB fuse	1) Is 1st fuse disconnected? 2) Is 2nd fuse disconnected?	. Over current . Indoor Fan motor short . AC part and pattern short of Indoor PBA
2	Supply power If the operating lamp twinkles at this time , the above 1)~3) have no relation	Check the power voltage	
		1) Is the BD71 input voltage 200Vac~240Vac?	. Power cord is fault, Fuse open, Wrong Power cable Wiring, AC part is faulty
		2) Is the voltage between both terminal of IC02 pin #1-#2 12Vdc?	. Switching Trans of Power circuit is faulty
3	Press the ON/OFF button 1. Fan speed(high) 2. Continuous Operation	3) Is the voltage between both terminal of IC02 pin #2-#3 5Vdc?	. Power circuit is faulty, Load short
		1) Is the voltage over AC 180V being imposed on terminal #3-#5 of fan motor connector (CN72)?	. Fan motor of the indoor is faulty
		2) The fan motor of the indoor unit doesn't run	. Fan motor connector(CN72) is faulty
		3) The power voltage between terminal #3-#5 of the connector(CN72) is 0V	. PBA is faulty

12-3-4 Outdoor detailed inspection procedure

No	procedure	Inspection Method	Cause
1	Plug out and pull the PCB out of the control box Check the PCB fuse (Wait 3 minutes after power off)	1) Is 1st fuse disconnected?	. Over current . AC part and pattern short of Outdoor PBA
2	Check the Wiring	1) Is the Compressor wire connected clockwise? 2) Is the Reactor wire connected normal? 3) Is the Fan wire connected normal? 4) Is the 4way wire connected normal? 5) Is the sensor wire connected normal?	. Wrong assembly . Installation(service) condition is bad
3	Supply power and operate the set (Use Remote-control, button in indoor set) - A*V18P**	Check the power voltage	
		1) Is the voltage between Terminal block L-N 200Vac~240Vac?	. Power cord is faulty, Wrong Power cable Wiring . Fuse open . L, N, F1, F2 wire wrong wiring (Terminal Block-PBA)
		2) Is the C006 voltage 200Vac~240Vac?	. Power circuit is faulty . Load short
		4) Is the PFC050(#26-#27) voltage 200Vac~240Vac after 3 minutes later?	. Fuse open . L, N, F1, F2 wire wrong wiring (Terminal Block-PBA) . PTC020 open . RY021, RY022 is faulty . Outdoor Micom(IC201) error
		5) Is the CE101 voltage 280Vdc~320dc after 3 minutes later?	. PFC050 is faulty . Reactor wire is wrong connection . Power circuit is faulty, Load short . BLDC Fan motor error
		6) Is the voltage CE154 voltage 15Vdc?	. Switching Trans of Power circuit is faulty . Load short
		7) Is the voltage CE155 voltage 3.3Vdc?	. Switching Trans of Power circuit is faulty
		8) Is the voltage CE158 voltage 5Vdc?	. Switching Trans of Power circuit is faulty
		9) Is the voltage CE157 voltage 12Vdc?	. Switching Trans of Power circuit is faulty . Load short
		3	Supply power and operate the set (Use Remote-control, button in indoor set) - A*V24***
1) Is the voltage between Terminal block L-N 200Vac~240Vac?	. Power cord is faulty, Wrong Power cable Wiring . Fuse open . L, N, F1, F2 wire wrong wiring (Terminal Block-PBA)		
2) Is the C002 voltage 200Vac~240Vac?	. Power circuit is faulty . Load short		
4) Is the PFCM(#26-#27) voltage 200Vac~240Vac after 3 minutes later?	. Fuse open . L, N, F1, F2 wire wrong wiring (Terminal Block-PBA) . PTC001 open . RY001, RY002 is faulty . Outdoor Micom(IC501) error		
5) Is the CE001 voltage 280Vdc~320dc after 3 minutes later?	. PFCM is faulty . Reactor wire is wrong connection . Power circuit is faulty, Load short . BLDC Fan motor error		
6) Is the voltage CE110 voltage 15Vdc?	. Switching Trans of Power circuit is faulty . Load short		
7) Is the voltage CE105 voltage 3.3Vdc?	. Switching Trans of Power circuit is faulty		
8) Is the voltage CE106 voltage 5Vdc?	. Switching Trans of Power circuit is faulty		
9) Is the voltage CE108 voltage 12Vdc?	. Switching Trans of Power circuit is faulty . Load short		
4	Check the LED lamp display		



## 12-4 Main Part Inspection Method

Part	Breakdown Inspection Method	
<b>Room Temperature Sensor</b>	Measure resistance with a tester	
	Normal	At the normal temperature 37kΩ~ 8.3kΩ(-7°C~+30°C)
	Abnormal	∞, 0Ω . . . Open or Short
<b>Room Fan Motor</b>	Measure the resistance between terminals of the connector (CN72) with a tester.	
	Abnormal	∞, 0Ω . . . Open or Short
<b>Stepping Motor</b>	Measure the resistance between the red wire and each terminal wire with a tester.	
	Normal	About 300Ω at the normal temperature (20°C ~ 30°C)
	Abnormal	∞, 0Ω . . . Open or Short

# 13. Block Diagram

## 13-1 Indoor Unit

\* : OPTION

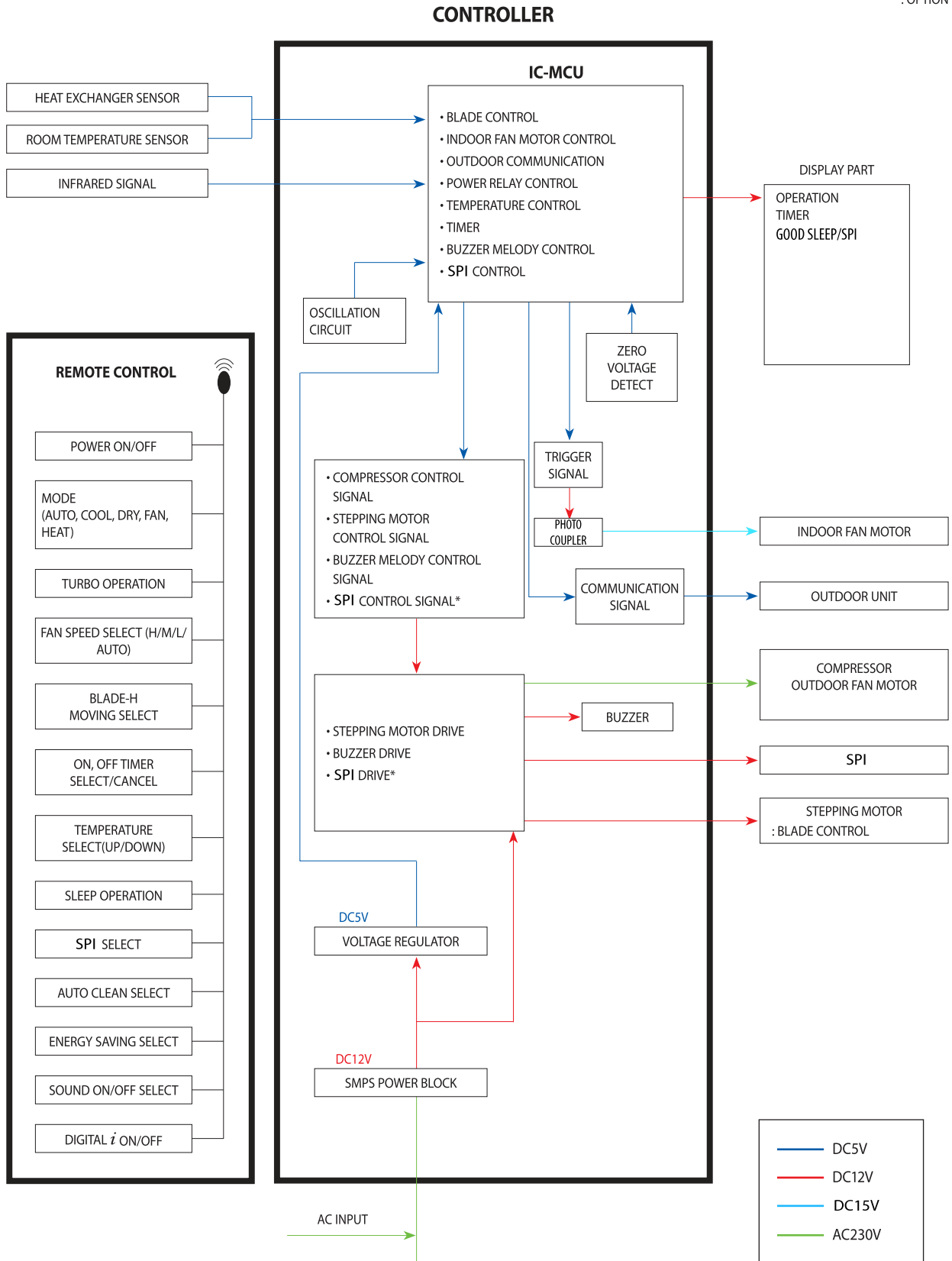

# 13-2 Outdoor Unit

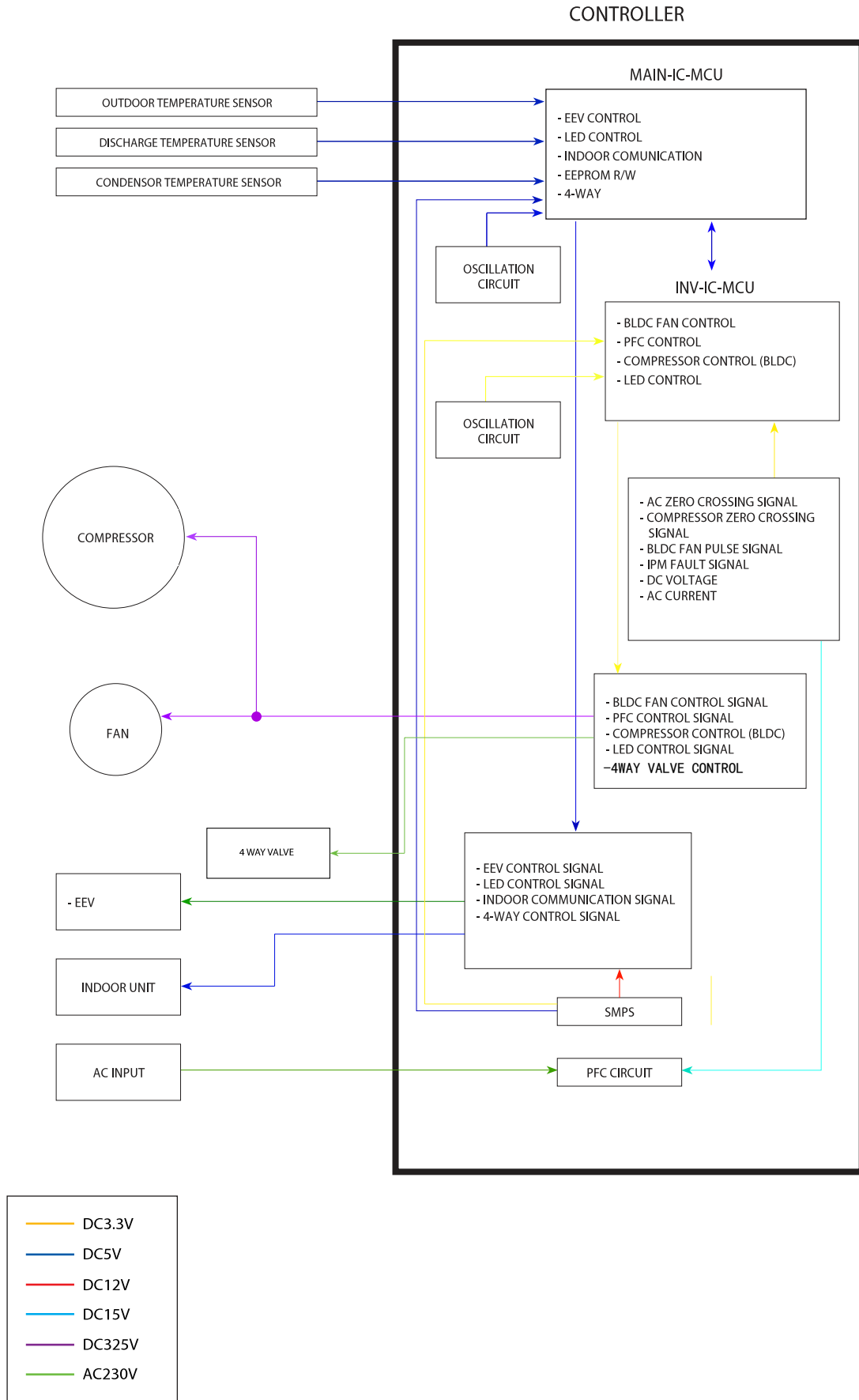

# 14. Reference Sheet

## 14-1 Index for Model Name

### Model Code

Digit No	1st	2nd	3rd	4th	5th	6th	7th	8th	9th	10th	11th	12th	13th	14th
属性			室内机	容量		Feature		Series		Color		/	Buyer	
事例	A	Q	N	0	9	V	F	U	A	G	M	/	C	V

#### 1,2

ITEM	1ST	2ND
RAC H/P	A	Q
RAC C/O	A	S
FAC H/P	A	H
FAC C/O	A	F
WAC H/P	A	Z
WAC C/O	A	W
PAC H/P	A	P
PAC C/O	A	B

#### 3

ITEM	3RD
Indoor	N
Outdoor	X
제트	-

#### 4,5

ITEM	(备注)	4TH	5TH
1	出口 BTU/H, 室内 PY	0	1
2	出口 BTU/H, 室内 PY	0	2
3	出口 BTU/H, 室内 PY	0	3
4	出口 BTU/H, 室内 PY	0	4
----			

#### 6

ITEM1	ITEM2	6TH
出口	INVERTER	V
出口	变频 R410A	S
出口	变频 R22	R
出口	HEATER	W
室内	INVERTER	H
室内	变频 R22	C
室内	TCS	T

#### 7

ITEM1	ITEM2	7TH
出口	6PI ( 인도/호남미 A/PAC K호)	S
出口	NO 6PI ( 인도/호남미 A/PAC K호)	F
出口	호남미 A호형(115V, 60Hz, 10)	A
出口	호남미 A호형 6PI	Z
出口	PAC K호형(220V, 60Hz, 30)	K
出口	PAC K호형 6PI	Y

#### 8,9

ITEM1	ITEM2	ITEM3	4	(국문호조호)	6TH	9TH
出口	RAC	CRYSTAL	16T MODEL	-	E	A
出口	RAC	CRYSTAL	인도 LOW-WATT 16T	-	E	B
出口	RAC	CRYSTAL	인도 6TF 6PI 16T	-	E	C
出口	RAC	JUNGFRAU-RLG	16T MODEL	-	K	A
出口	RAC	MALDIVES	16T MODEL	-	P	A
----						

#### 10,11

区分	Color	Color Code	Color	Color Code
Standard	WHITE	W	CAMELIA WHITE	A
Standard	WHITE		CEZANNE2 WHITE	B
Standard	WHITE		CREAM WHITE	C
Standard	WHITE		CRYSTAL WHITE (GLOSSY WHITE)	D
----				

#### 13,14

No	기호코드	판매 지역	동호코드
1	AFR	AFRICA	AF
2	FMC	AFRICA	FM
3	SIM	AFRICA	SI
4	SAH	ALGERIA	LR
5	UPC	ALGERIA	PC
6	YAM	ALGERIA	YA
7	SAM	ALGIERS	LS
8	KCV	AMERICA	CV
----			

#### 12

ITEM1	ITEM2	ITEM3	12TH
出口		연경호	/
出口		CKD	C
出口		SKD	S
出口		(영업가상코드) UNIVERSAL FJM 실내기	U
室内		(공통) MOCK-UP	M
室内		(개발용 8ET코드) 단품, 2미터	3
室内		(개발용 8ET코드) 3미터	4
室内		(개발용코드) IN/OUT (흑열티용 INDOOR 제외)	D
室内		(개발용코드) 흑열티용 INDOOR	Q
室内	SET	(영업가상 8ET코드) 단품, 2미터	호
室内	SET	(영업가상 8ET코드) 3미터	2
室内	FAC, PAC IN/OUTDOOR	(영업가상코드) FAC, PAC IN/OUT DOOR	호
室内	RAC IN/OUTDOOR	(영업가상코드) 단품 RAC IN/OUT DOOR	호
室内	흑열티용 RAC INDOOR	(영업가상코드) 2미터	호
室内	흑열티용 RAC INDOOR	(영업가상코드) 3미터	2

## 14-3 Pressure & Capacity mark

---

### ■ Power/Heat

W	cal/s	kcal/h	Btu/h	HP	kg·m/s	lb·m/s
1	0.23885	0.85985	3.4121	0.001341	0.10197	0.73756
4.1868	1	3.6	14.286	0.0056146	0.42693	3.088
1.163	0.27778	1	3.9683	0.0015596	0.11859	0.85778
0.29307	0.06999	0.252	1	$3.9302 \times 10^{-4}$	0.029885	0.21616
745.7	178.11	641.19	2,544.4	1	76.04	550
9.8067	2.3423	8.4322	33.462	0.013151	1	7.233
1.3558	0.32383	1.1658	4.6262	0.0018182	0.13826	1

## 14-4 Q & A for Non-trouble

Classification	Class	Description
Cooling	Q	<b>The cooling is weak.</b>
	A	When it is hot outside, its cooling capacity decreases due to the increase of the ambient temperature. When the dust filter gets blocked or warm outside air gets in, the cooling capacity will decrease. So, make sure to clean the dust filter frequently, prevent heat loss by closing the doors and insulate the cooling area by using curtains, blinds, shades or window tinting.
	Q	<b>The cooling is good generally. But, it gets weak when it is considerably hot.</b>
	A	It occurs when the outdoor unit is exposed to direct sun light and heat-up air is not ventilated well. So, set up a sunblind over the outdoor unit and keep stuff away from the unit to increase the ventilation. When the cooling capacity decreases during a heat wave, clean the heat exchanger of the outdoor unit or spray some cold water to the heat exchanger to increase the cooling capability.
	Q	<b>The cooling is weak. Does it need refrigerant charging?</b>
	A	It is not correct charging refrigerant regularly. Except that you have moved in several times or the connection pipes are broken, the refrigerant does not run low. So, when refrigerant is additionally charged, it could be costly and cause a product's failure. When the refrigerant leaks, all of it will escape in a short time resulting in cooling failure and no water coming out of the drain hose. So, if water comes out from the drain hose, it indicates the normal operation of the product and it does not need refrigerant charging.
	Q	<b>It fails to do cooling.</b>
A	When the air conditioner is set to Ventilation or the desired temperature is set higher than the current temperature, it fails to do cooling. In this case, select Cooling or set the desired temperature lower.	
Leakage	Q	<b>It floods the floor.</b>
	A	Place the drain hose properly. When it is not placed properly, the drain water would flow back flooding the floor. So, straighten out the drain hose for the water to be drained well.
	Q	<b>Water drips at the drain connection (service valve) of the outdoor unit.</b>
	A	When a glass bottle is taken out of the refrigerator, moisture gets condensed on its surface due to the temperature differences. The same principle applies to the air conditioner. When cold refrigerant goes through the copper tube, moisture gets condensed on the surface of the tube and the connection areas. To prevent the water condensation, the pipes are insulated. But, the connection areas of the outdoor unit are not insulated for the purpose of maintenance or repair, and water gets condensed due to the temperature differences and drips down. Generally, it evaporates right away. But, when it drips much during muggy days, put a water pan on the floor.
	Q	<b>It leaks even though a drain pump is used.</b>
A	It occurs when the drain pump is plugged out or it is out of order. Check the power of the drain pump and the position of the drain hose, and when the pump is faulty, contact the drain pump manufacturer. Samsung Electronics do not manufacture drain pumps. So, we are not able to correct the drain pump problems.	
Smells	Q	<b>Whenever the air conditioner is turned on, it irritates my eyes and gives me a headache.</b>
	A	There are no components in the air conditioner irritating the eyes and sending out chemical smells. But, when the air conditioner is turned on, other smell sources are sucked into the air conditioner and get out of it. So, find and root out the smell sources. Generally, it occurs at a interior renovated place, a pharmacy, a gasoline handling place, a tire shop, a second-hand book shop or an electronic component handling place; when its chemical or musty smells are sucked in and sent out, it can be misled that the air conditioner generates them. So, find and root out the problem or refresh the room frequently.

Classification	Class	Description
Smells	Q	<b>Whenever the air conditioner is turned on, it stinks.</b>
	A	There are no components in the air conditioner sending out chemical smells. But, when the air conditioner is turned on, other smell sources are sucked into the air conditioner and get out of it. So, find and root out the smell sources. Generally, when the drain hose is taken out to the washing room or there are sources of smells such as a diaper bin, a shoe shelf or a socks bin, bad smells generate. Also, it occurs where glass cleaners or air fresheners are used; when they are sucked in interacting with dusts and moistures inside, bad smells generate. These kinds of organic materials noxious to human bodies. So, we recommend against the use of them.
	Q	<b>Whenever the air conditioner is turned on, it smells sour.</b>
	A	When the room is papered recently, its paste smells would be sucked inside. Also, when the air conditioner is installed in the study room of young boys loving sweat-generating activities such as the basketball, excessive sweats evaporate and get sucked into the air conditioner resulting in bad smells. So, find and root out the problem or refresh the room frequently.
	Q	<b>Whenever the air conditioner is turned on, it smells musty.</b>
	A	It is due to the improper keeping of the product after its use. When keeping the product, dry up the inside with the operation of Ventilation to prevent must. When the product is kept without drying up the inside with Ventilation, mold would grow inside resulting in must. So, open the windows and switch on the Ventilation function to get rid of the saturated smell inside.
	Q	<b>Whenever the air conditioner is turned on, it sends out bad smells such as stale smells.</b>
	A	It occurs generally when there are pet animals in the house. Their smells stay at the same place. But, when the air conditioner is turned on, the air gets circulated resulting in the circulation of the smells. So, find and root out the problem or refresh the room frequently.
Operation	Q	<b>It won't start.</b>
	A	There is a power failure or it is plugged out. Also, check if the power distribution panel is switched off.
	Q	<b>It goes off during operation.</b>
	A	When the hot air does not escape properly, it goes off during operation. It occurs when it does not ventilate properly because the outdoor unit is covered, the back of the outdoor unit is blocked by a cardboard or a plywood panel, and the front of the outdoor unit is blocked by the closed window or other obstacles. Clear the above obstacles from the outdoor unit.
	Q	<b>It generally works properly. But, when it's considerably hot, it goes off during operation.</b>
	A	It occurs when the outdoor unit is exposed to direct sunlight and the hot air does not escape properly. Set up a sun blind over the outdoor unit and clear the neighboring obstacles from the outdoor unit to provide good ventilation. When it goes off frequently during a heat wave, it would prevent the turn-off and increase the cooling capacity cleaning the outdoor unit or spraying some water to the heat exchanger.
	Q	<b>The remote controller won't operate.</b>
	A	When the batteries run out or the transmitter or receiver of the remote controller is blocked by obstacles, change the batteries or keep the obstacles away from the controlling area. Also, the remote controller may not work under intensive light from a 3-wave length lamp or a neon sign due to the EMI. In this case, take the remote controller closer to the receiver.

Classification	Class	Description
Installation	Q	<b>Who installs the air conditioner? (Relocation/Re-installation)</b>
	A	When relocating or re-installing the air conditioner, make sure to contact Samsung Electronics Service Center or Authorized Service Agent and have them to do the job. (If not, it could cause personal injury or product damage.) The cost for the relocation/re-installation of the air conditioner is subject to the customer's expense. There is a cost table. But, our service engineer needs to visit to total up the cost correctly. When you move in, make sure to contact Samsung Electronics Service Center or Authorized Service Agent in advance to streamline the process.
	Q	<b>Is it possible to install the outdoor unit outside?</b>
	A	It is possible to install it at a designated place in the apartment or on the rooftop nearby. But, it's illegal hanging an angle iron case with the outdoor unit in it outside the apartment. Also, it is illegal obstructing passers-by with the outdoor unit installed outside.
	Q	<b>What can be done to install the outdoor unit facing the road because it is a commercial building?</b>
	A	The following is an excerpt from Building Code going into effect from JUNE 1st 2005. "The exhaust pipe of a cooling or ventilation facility installed in a building adjacent to the streets of commercial or residential areas shall be installed higher than 2 m to prevent the exhaust air from blowing directly to passers-by and the current facilities shall be corrected by MAY 31st 2005." So, please install it higher than 2 m or not to blow the hot exhausting air directly to passers-by.
	Q	<b>What about installing a windscreen during installation not to blow hot air directly to passers-by?</b>
	A	When the hot air from the front of the outdoor unit is blocked, the product's performance will be affected and it will fail to operate properly. So, keep it at least 300mm away from its surrounding walls and give it good ventilation.



## 14-5 Cleaning/Filter Change

### 14-5-1 Cleaning your Air Conditioner

To get the best possible use out of your air conditioner, you must clean it regularly to remove the dust that accumulates on the air filter.



• Before cleaning your air conditioner, ensure that you have switched off the breaker used for the unit.

#### Opening the panel

Tightly grab top of the front panel and pull it down to open. Then slightly lift the panel up.

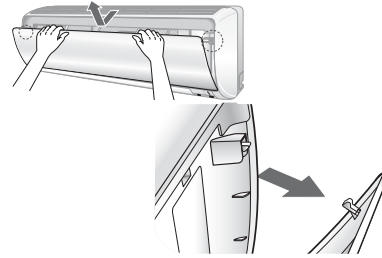

#### Removing the Air filter

Grab the handle and lift it up. Then, pull the Air filter towards you and slide it down.

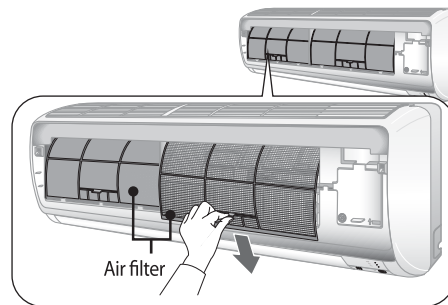

#### Cleaning the air filter

Washable foam based air filter captures large particles from the air. The filter is cleaned with a vacuum or by hand washing.

Open the panel and put the Air filter out.

Clean the Air filter with a vacuum cleaner or soft brush. If dust is too heavy, rinse it with running water.

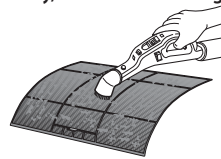

Insert the Air filter back in its original position and close the front panel.

Dry the Air filter in a ventilated area.

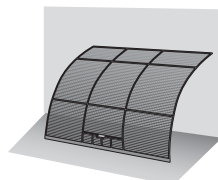

- Clean the Air filter every 2 weeks or when the filter clean reminder lights up. Cleaning term may differ depending on the usage and environmental conditions. In dusty area, clean it once a week.
- If you turn off the air conditioner by pressing **Power**  button, the filter clean reminder will be turned off.
- If the Air filter dries in a confined (or humid) area, odors may generate. If it occurs, re-clean and dry it in a well-ventilated area.

### 14-5-2 Cleaning Deodorizing and Bio filter (Option)

To remove minute dust particles and odors, deodorizing and Bio filter are installed in the air conditioner. You should clean the filters every 3 months.

1. Open the upper front grille by pulling the lower right and left tabs of the grille.
2. Pull out the deodorizing and Bio filter.
3. Wash the filters with clean water, then dry them in the shade.
4. Insert the filters into the original position.  
**Note** : • You can change the position of filters with each other.
5. Close the front grille.

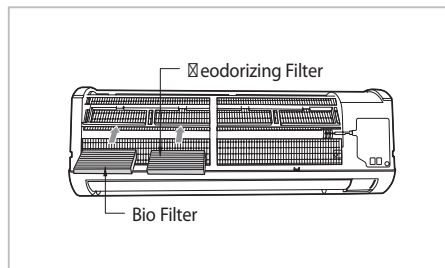

## 14-6 Installation

### 14-6-1 Before Installation

Keep the air conditioner outlet and inlet free from its surroundings.  
In case of installation, keep the symmetry and fix it to prevent vibration.  
The pipe length shall meet the standard as far as possible.

### 14-6-2 Installation Procedure

#### ■ Location

Install the product in an area to guarantee the best cooling effect, convenience of piping and electric work, and inexistence of vibration or wind.

#### ■ Wall Drilling

Drill the wall downward in a diameter of 60 to 65mm.

#### ■ Fixing Indoor Unit & Outdoor Unit

Fix the air conditioner indoor unit securely to the wall. Secure the outdoor unit in a suitable position.

#### ■ Pipe Spooling & Connecting

You shall cut the pipe with a pipe cutter and grind all the burrs of the cut surface.  
Pipe expansion may continue until the pipe surface becomes uneven or torn apart.  
Be sure to use a torque wrench to tighten pipes or flare nuts.

<Torque & Depth>

Outer Diameter(D)	Torque(kgf·cm)	Depth(A)
6.35mm(1/4")	140~170	1.3mm
9.52mm(3/8")	250~280	1.8mm
12.70mm(1/2")	380~420	2.0mm
15.88mm(5/8")	440~480	2.2mm
19.05mm(3/4")	990~1,210	2.2mm

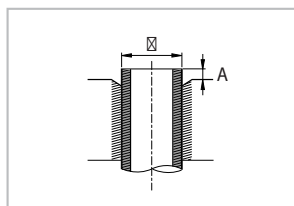

#### ■ Leak Test

Put an inert gas like nitrogen in the outdoor unit pipe and put soap bubbles or other test liquids on the pipe surface for the leak test.

#### ■ Drain Hose Connecting

Install the drain hose downward to drain water naturally. Be sure to pour water into the hose to check if it drains well.

#### ■ Electric & Earth Work

Electric and earth work shall meet the "Electric Facility Technology Standard" and the "Internal Wire Regulation" of the Electric Business Laws.

#### ■ Inspection & Trial Run

Upon completion of the tests, you shall make a trial run while you explain the main functions of the air conditioner to finish the installation.

# 14-7 Installation Diagram of Indoor Unit and Outdoor Unit

## 14-7-1 Air-Purge Procedure

1) Connect each assembly pipe to the appropriate valve on the outdoor unit and tighten the flare nut.



2) Connect the charging hose of low pressure side of manifold gauge to the packed valve having a service port as shown at the figure.



3) Open the valve of the low pressure side of manifold gauge counter-clockwise.



4) Purge the air from the system using vacuum pump for about 30 minutes.

- Make sure that pressure gauge show -0.1MPa(-76cmHg) after about 30 minutes.
- This procedure is very important in order to avoid gas leak.
- Turn off the vacuum pump.
- Close the valve of the low pressure side of manifold gauge clockwise.
- Remove the hose of the low pressure side of manifold gauge.



5) Set valve cork of both liquid side and gas side of packed valve to the open position.



6) Mount the valve stem nuts and the service port cap to the valve, and tighten them at the torque of 183kgf-cm with a torque wrench.



7) Check for gas leakage.

- At this time, especially check for gas leakage from the 3 way valve's stem nuts, and from the service port cap.

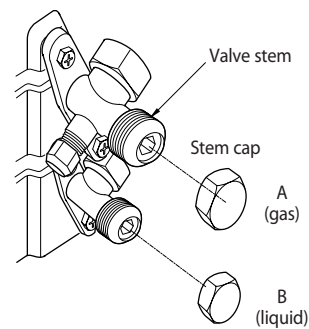
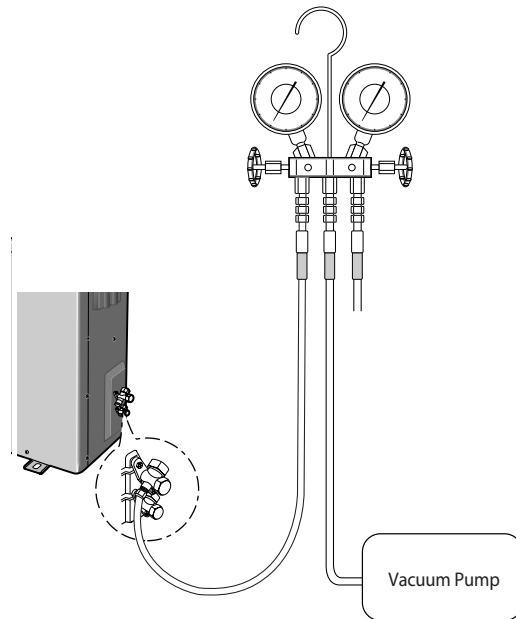
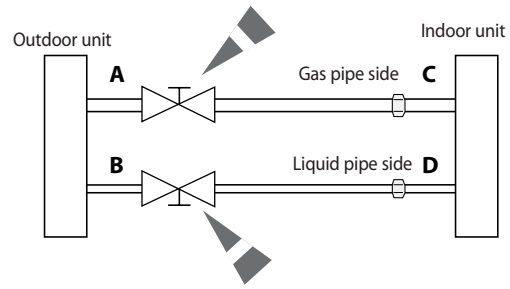

## 14-7-2 "Pump down" Procedure

Pump down will be carried out when an evaporator is replaced or when the unit is relocated in another area.

1) Remove the caps from the 3 way valve and the 3-Way valve.



2) Turn the 3-Way valve clockwise to close and connect a pressure gauge (low pressure side) to the service valve, and open the 3 way valve again.



3) Set the unit to cool operation mode.  
(Check if the compressor is operating.)



4) Turn the 3-Way valve clockwise to close.



5) When the pressure gauge indicates "0" turn the 3-Way valve clockwise to close.



6) Stop operation of the air conditioner.



7) Close the cap of each valve.

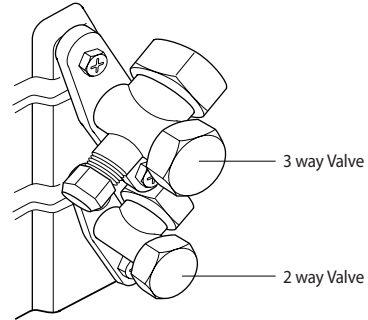

### Remarks

#### Relocation of the air conditioner

- Refer to this procedure when the unit is relocated.
- Carry out the pump down procedure (refer to the details of 'pump down').
- Remove the power cord.
- Disconnect the assembly cable from the indoor and outdoor units.
- Remove the flare nut connecting the indoor unit and the pipe.
- At this time, cover the pipe of the indoor unit and the other pipe using a cap or vinyl plug to avoid foreign material entering.
- Disconnect the pipe connected to the outdoor unit.  
At this time, cover the valve of the outdoor unit and the other pipe using a cap or vinyl plug to avoid foreign material entering.
- Make sure you do not bend the connection pipes in the middle and store together with the cables.
- Move the indoor and outdoor units to a new location.
- Remove the mounting plate for the indoor unit and move it to a new location.

## 15-1. POWER SUPPLY

<b>Working Voltage</b>	176V ~ 264V
<b>Voltage Imbalance</b>	Within a 3% Deviation from Each Voltage at the Main Terminal of Outdoor Unit
<b>Starting Voltage</b>	Higher than 80% of the Rated Voltage

## 15-2. WORKING RANGE

Applicable models:

AQ-09VFUAGM/CV  
 AQ-12VFUAGM/CV  
 AQ-18VFUAGM/CV  
 AQ-24VFUAGM/CV  
 AQ-36VFUAGM/CV

The temperature range is indicated in the following table.

### Cooling

working range	min (°C)	max (°C)	rated (°C)
outdoor	-10	46	35
indoor	16	32	27

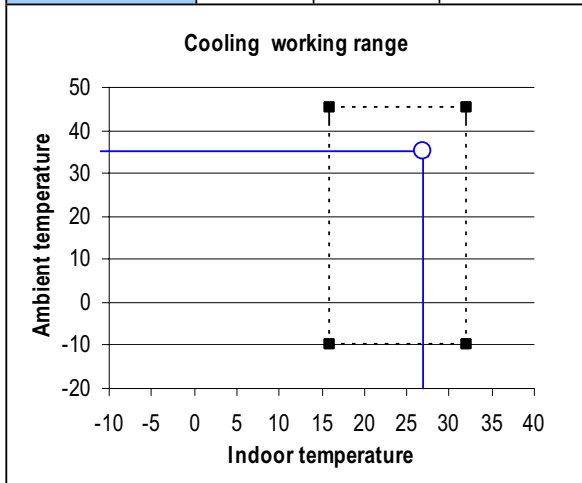

### Heating

working range	min (°C)	max (°C)	rated (°C)
outdoor	-15	24	7
indoor	—	27	20

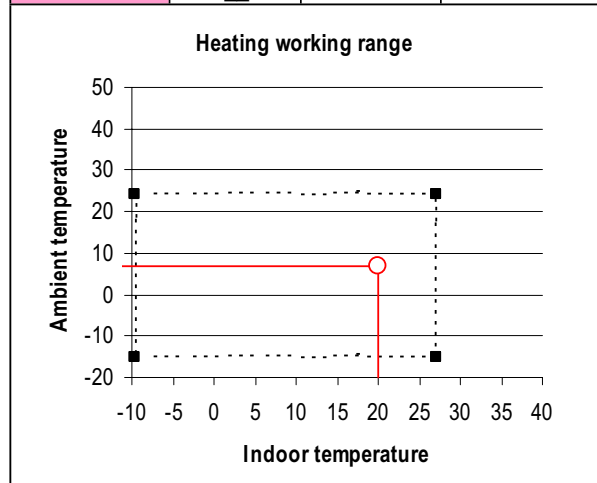



**GSPN(Global Service Partner Network)**

Area	Web Site
North America	<a href="http://service.samsungportal.com">http://service.samsungportal.com</a>
Latin America	<a href="http://latin.samsungportal.com">http://latin.samsungportal.com</a>
CIS	<a href="http://cis.samsungportal.com">http://cis.samsungportal.com</a>
Europe	<a href="http://europe.samsungportal.com">http://europe.samsungportal.com</a>
China	<a href="http://china.samsungportal.com">http://china.samsungportal.com</a>
Asia	<a href="http://asia.samsungportal.com">http://asia.samsungportal.com</a>
Mideast & Africa	<a href="http://mea.samsungportal.com">http://mea.samsungportal.com</a>

This Service Manual is a property of Samsung Electronics Co., Ltd.  
Any unauthorized use of Manual can be punished under applicable  
International and/or domestic law.

© Samsung Electronics Co., Ltd. Nov. 2007.  
Printed in China.