



Air conditioning & Heating

# Installer's Guide

---

## Condensing Units

### VEV GOLDTEC SERIES

Split System Heat Pump & Air Conditioner  
Up to 18 SEER  
2-5 Tons  
R410A

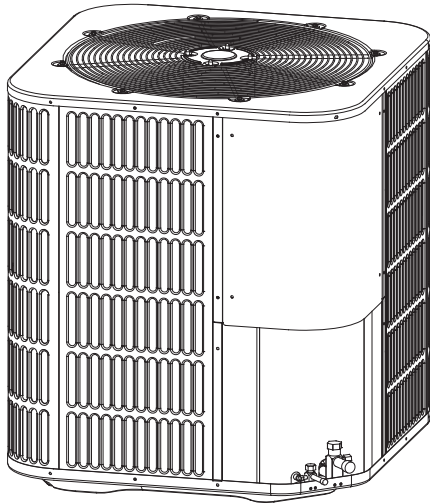

**NOTE:** Appearance of unit may vary.



ALL phases of this installation must comply with NATIONAL, STATE AND LOCAL CODES

---

**IMPORTANT** — This Document is customer property and is to remain with this unit. Please return to service information pack upon completion of work.

These instructions do not cover all variations in systems or provide for every possible contingency to be met in connection with the installation. Should further information be desired or should particular problems arise which are not covered sufficiently for the purchaser's purposes, the matter should be referred to your installing dealer or local distributor.

**Note :** *The manufacturer recommends installing only approved matched indoor and outdoor systems. All of the manufacturer's split systems are A.H.R.I. rated only with TXV indoor systems. Some of the benefits of installing approved matched indoor and outdoor split systems are maximum efficiency, optimum performance and the best overall system reliability.*

#### Table of Contents

Section 1. Safety.....	2
Section 2. Unit Location Considerations.....	3
Section 3. Unit Preparation.....	5
Section 4. Setting the Unit.....	5
Section 5. Refrigerant Line Considerations.....	6
Section 6. Refrigerant Line Routing.....	7
Section 7. Refrigerant Line Brazing.....	8
Section 8. Refrigerant Line Leak Check.....	10
Section 9. Evacuation.....	11
Section 10. Service Valves.....	11
Section 11. Electrical - Low Voltage.....	12
Section 12. Electrical - High Voltage.....	14
Section 13. Start Up.....	15
Section 14. System Charge Adjustment.....	16
Section 15. System operation and Troubleshooting.....	20

## Section 1. Safety

**Important** - This document contains a wiring diagram and service information. This is customer property and is to remain with this unit. Please return to service information pack upon completion of work.



### CAUTION

This information is intended for use by individuals possessing adequate backgrounds of electrical and mechanical experience. Any attempt to repair a central air conditioning product may result in personal injury and/or property damage. The manufacturer or seller cannot be responsible for the interpretation of this information, nor can it assume any liability in connection with its use.



### WARNING

#### HAZARDOUS VOLTAGE!

Failure to follow this warning could result in property damage, severe personal injury, or death.

Disconnect all electric power, including remote disconnects before servicing. Follow proper lockout/tagout procedures to ensure the power cannot be inadvertently energized.



### WARNING

#### REFRIGERANT OIL!

Any attempt to repair a central air conditioning product may result in property damage, severe personal injury, or death.

These units use R-410A refrigerant which operates at 50 to 70% higher pressures than R-22. Use only R-410A approved service equipment. Refrigerant cylinders are painted a "Rose" color to indicate the type of refrigerant and may contain a "dip" tube to allow for charging of liquid refrigerant into the system. All R-410A systems with variable speed compressors use a PVE oil that readily absorbs moisture from the atmosphere. To limit this "hygroscopic" action, the system should remain sealed whenever possible. If a system has been open to the atmosphere for more than 4 hours, the compressor oil must be replaced. Never break a vacuum with air and always change the driers when opening the system for component replacement.



### CAUTION

#### HOT SURFACE!

May cause minor to severe burning. Failure to follow this Caution could result in property damage or personal injury. Do not touch top of compressor.



### CAUTION

#### CONTAINS REFRIGERANT!

Failure to follow proper procedures can result in personal illness or injury or severe equipment damage.

System contains oil and refrigerant under high pressure. Recover refrigerant to relieve pressure before opening system.



### CAUTION

#### GROUNDING REQUIRED!

Failure to inspect or use proper service tools may result in equipment damage or personal injury.

Reconnect all grounding devices. All parts of this product that are capable of conducting electrical current are grounded. If grounding wires, screws, straps, clips, nuts, or washers used to complete a path to ground are removed for service, they must be returned to their original position and properly fastened.



### WARNING

#### SERVICE VALVES!

Failure to follow this warning will result in abrupt release of system charge and may result in personal injury and/or property damage. Extreme caution should be exercised when opening the Liquid Line Service valve. Turn valve stem counterclockwise only until the stem contacts the rolled edge. No torque is required.



### WARNING

#### BRAZING REQUIRED!

Failure to inspect lines or use proper service tools may result in equipment damage or personal injury.

If using existing refrigerant lines make certain that all joints are brazed, not soldered.



### WARNING

#### HIGH LEAKAGE CURRENT!

Failure to follow this warning could result in property damage, severe personal injury, or death.

Earth connection essential before connecting electrical supply.

## Section 2. Unit Location Considerations

### 2.1 Unit Dimensions

Unit Dimensions	
Models	H x W x L(Inches)
24/36	24-15/16 x 29-1/8 x 29-1/8
48/60	33-3/16 x 29-1/8 x 29-1/8

The unit's weight values is on the carton box.

When mounting the outdoor unit on a roof, be sure the roof will support the unit's weight. Properly selected isolation is recommended to prevent sound or vibration transmission to the building structure.

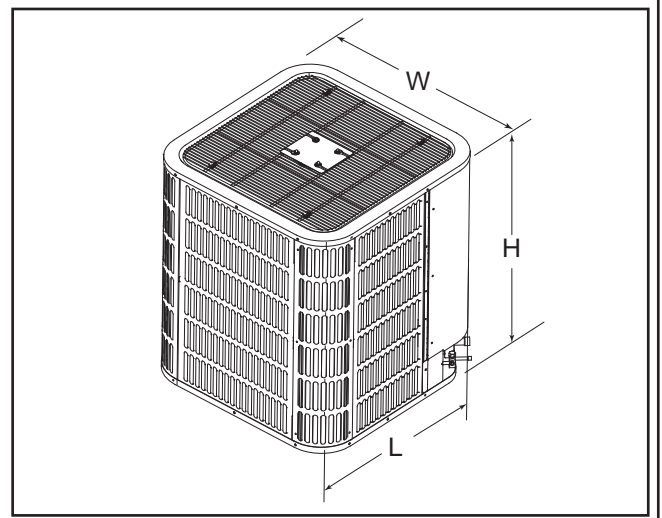

### 2.2 Refrigerant Piping Limits

- ☒ Maximum line length = 100 feet.
- ☒ Maximum vertical length = 50 feet.
- ☒ Compressor crankcase heat is required for line lengths over 50 feet.
- ☒ Use only the line diameters indicated in Table 5.1.
- ☒ Such as the connecting tube is more than 60 feet, does not use large Suction line than recommend.

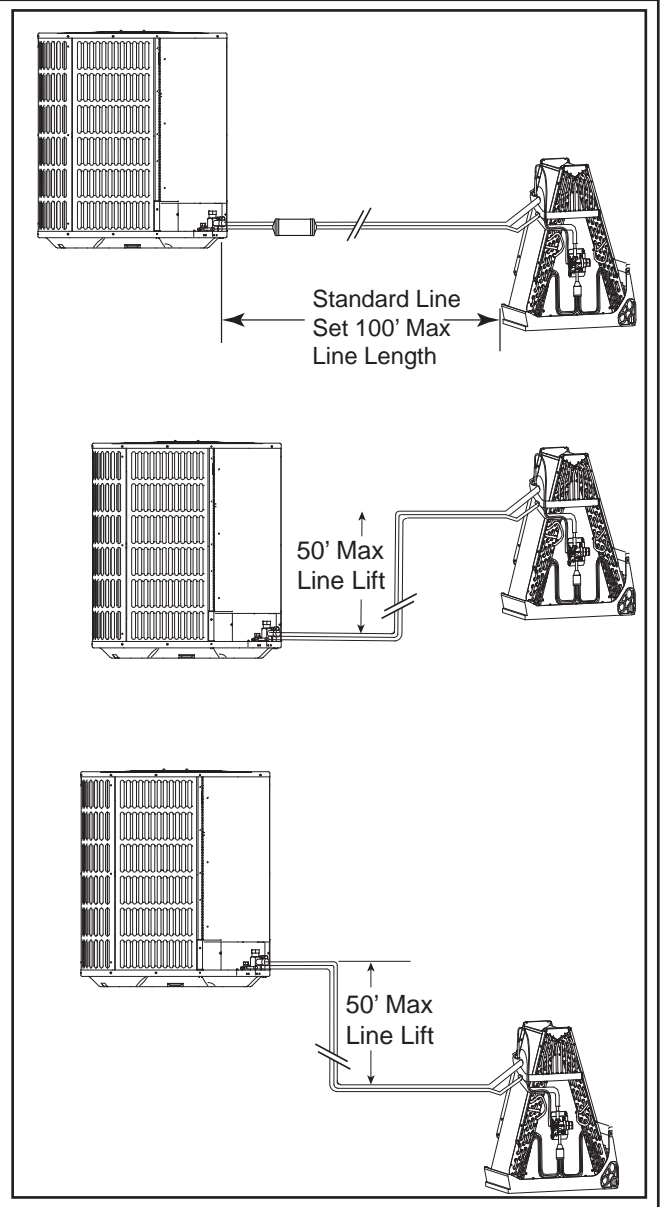

## 2.4 Location Restrictions

Ensure the top discharge area is unrestricted for at least 60 inches above the unit.

Clearance must be provided in front of the control box (access panels) and any other side requiring service.

Do not locate close to bedrooms, operational sounds may be objectionable.

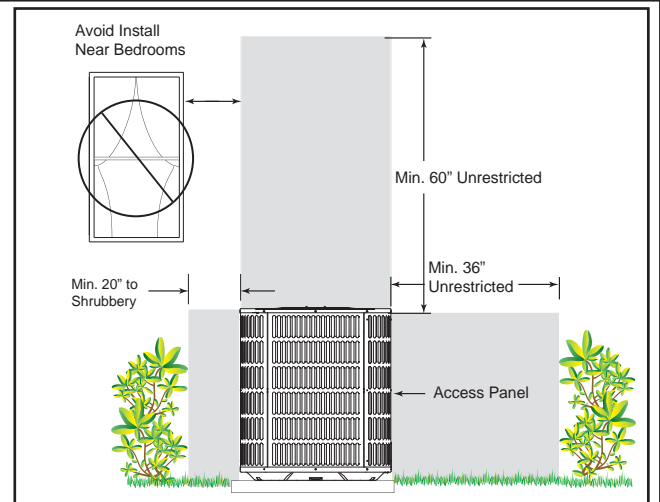

Position the outdoor unit a minimum of 20 inches from any wall or surrounding shrubbery to ensure adequate airflow.

Outdoor unit location must be far enough away from any structure to prevent excess roof runoff water from pouring directly on the unit.

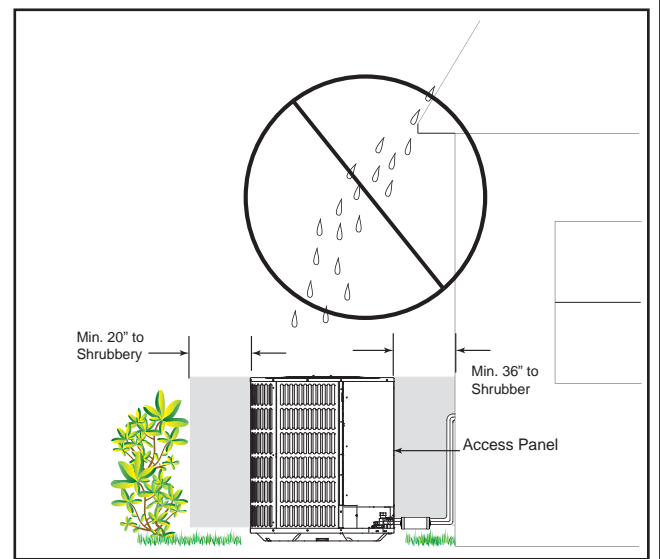

### Cold Climate Considerations (Heat Pump Only)

Note: It is recommended that these precautions be taken for units being installed in areas where snow accumulation and prolonged below-freezing temperatures occur.

- Units should be elevated 3-12 inches above the pad or rooftop, depending on local weather. This additional height will allow drainage of snow and ice melted during defrost cycle prior to its refreezing. Ensure that drain holes in unit base pan are not obstructed, preventing drainage of defrost water.
- If possible, avoid locations that are likely to accumulate snow drifts. If not possible, a snow drift barrier should be installed around the unit to prevent a build-up of snow on the sides of the unit.

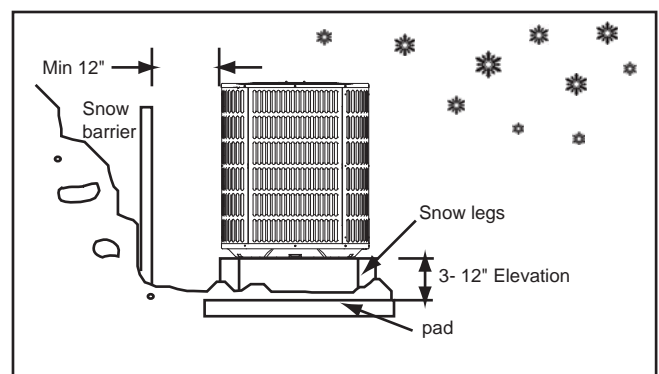

## Section 3. Unit Preparation

### 3.1 Prepare The Unit For Installation

**STEP 1** - Check for damage and report promptly to the carrier any damage found to the unit.

The charge port can be used to check to be sure the refrigerant charge has been retained during shipment.

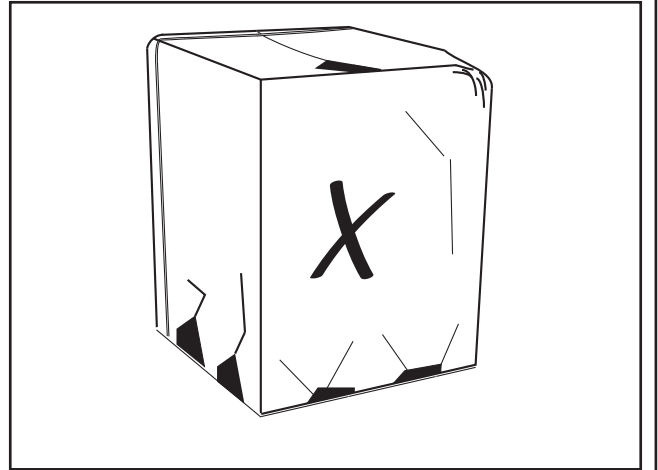

## Section 4. Setting the Unit

### 4.1 Pad Installation

When installing the unit on a support pad, such as a concrete slab, consider the following:

- The pad should be at least 1-2" larger than the unit on all sides.
- The pad must be separate from any structure.
- The pad must be level.
- The pad should be high enough above grade to allow for drainage.
- The pad location must comply with National, State, and Local codes.

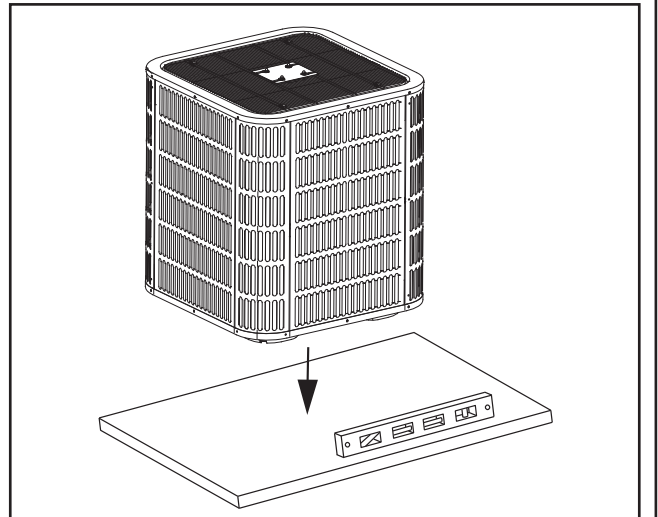

#### IMPORTANT NOTE:

These instructions are intended to provide a method to tie-down system to cement slab as a securing procedure for high wind areas. It is recommended to check Local Codes for tie-down methods and protocols.

#7 X 3/8" Self Tapping Screws  
(Don't Exceed 3/8" long)

Brackets:  
2" width, 1/16" thickness,  
height as required.  
Available from distributor  
or in market place.

DETAIL A

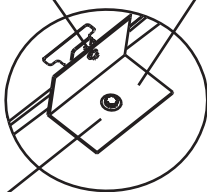

1/4" X 1-1/2" Hex Washer Head Concrete Screws  
(3/16" Pilot Hole Needed. Pilot Hole Should Be 1/4" Deeper  
Than The Fastener Embedment)

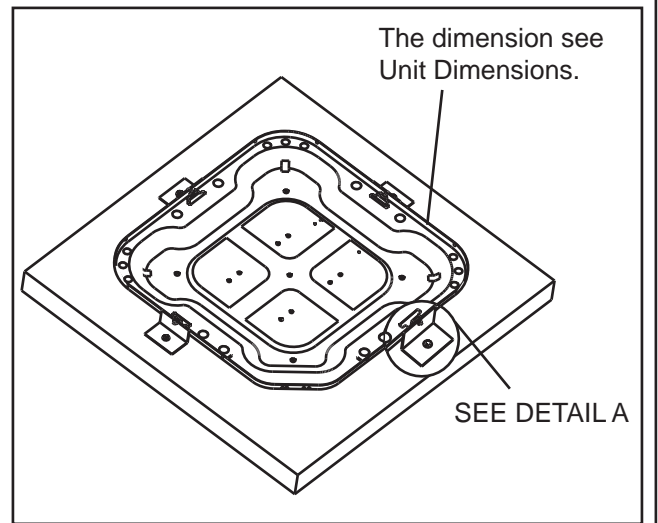

## Section 5. Refrigerant Line Considerations

### 5.1 Refrigerant Line and Service Valve Connection Sizes

Table 5.1

Model	Line Sizes		Service Valve Connection Sizes	
	Suction Line	Liquid Line	Suction Line Connection	Liquid Line Connection
24/36	3/4	3/8	3/4	3/8
48/60	7/8	3/8	7/8	3/8

### 5.2 Required Refrigerant Line Length

Determine required line length.

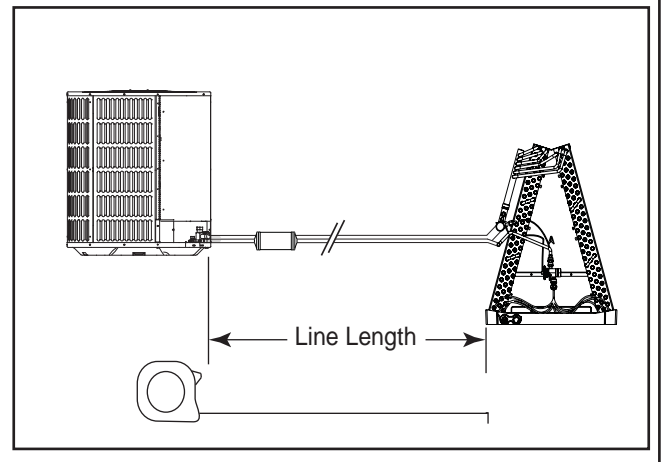

### 5.3 Refrigerant Line Insulation

**Important:** The Suction Line must always be insulated. DO NOT allow the Liquid Line and Suction Line to come in direct (metal to metal) contact.

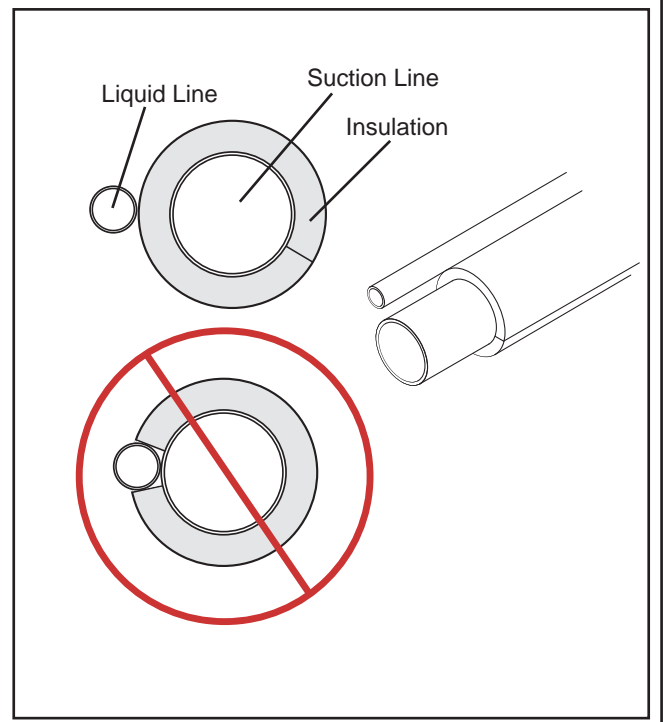

## 5.4 Reuse Existing Refrigerant Lines

### ⚠ CAUTION

If using existing refrigerant lines make certain that all joints are brazed, not soldered.

For retrofit applications, where the existing refrigerant lines will be used, the following precautions should be taken:

- ☒ Ensure that the refrigerant lines are the correct size. Refer to Section 2.2 listed and Table 5.1.
- ☒ Ensure that the refrigerant lines are free of leaks, acid, and oil.

**Note:** The manufacturer recommends installing only approved matched indoor and outdoor systems. All of the manufacturer's split systems are A.H.R.I. rated only with TXV indoor systems. Some of the benefits of installing approved matched indoor and outdoor split systems are maximum efficiency, optimum performance and the best overall system reliability.

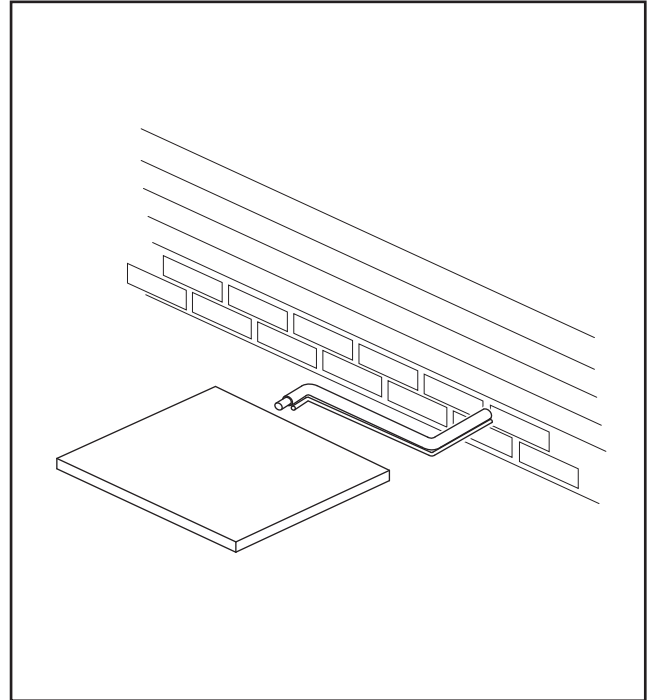

## Section 6. Refrigerant Line Routing

### 6.1 Precautions

**Important:** Take precautions to prevent noise within the building structure due to vibration transmission from the refrigerant lines.

Comply with National, State, and Local Codes when isolating line sets from joists, rafters, walls, or other structural elements.

For Example:

- ☒ When the refrigerant lines have to be fastened to floor joists or other framing in a structure, use isolation type hangers.
- ☒ Isolation hangers should also be used when refrigerant lines are run in stud spaces or enclosed ceilings.
- ☒ Where the refrigerant lines run through a wall or sill, they should be insulated and isolated.
- ☒ Isolate the lines from all ductwork.
- ☒ Minimize the number of 90° turns.

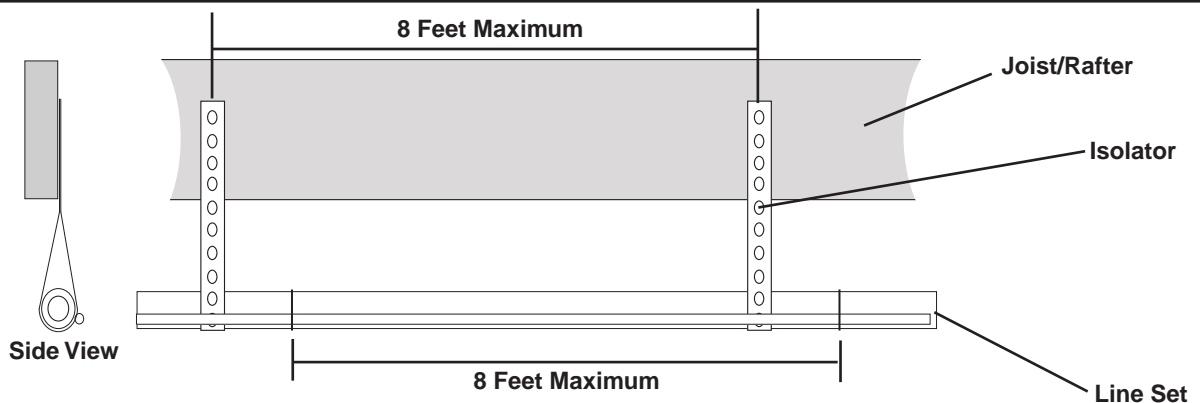

Secure Suction line from joists using isolators every 8 ft. Secure Liquid Line directly to Suction line using tape, wire, or other appropriate method every 8 ft.

Isolation From Joist/Rafter



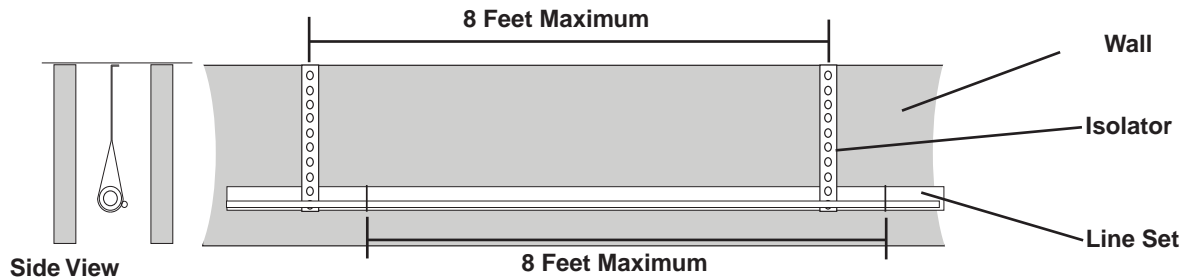

Secure Suction Line using isolators every 8 ft. Secure Liquid Line directly to Suction Line using tape, wire, or other appropriate method every 8 ft.

Isolation In Wall Spaces

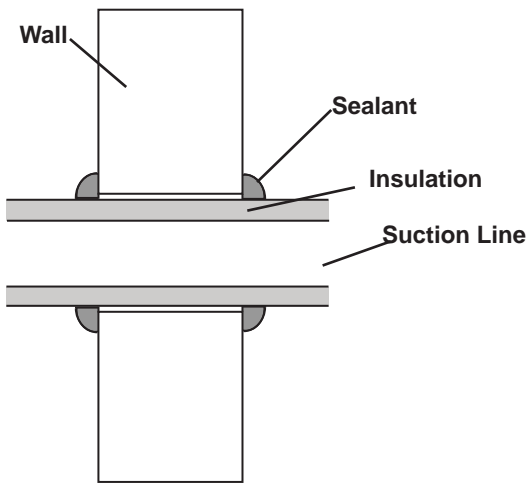

Isolation Through Wall

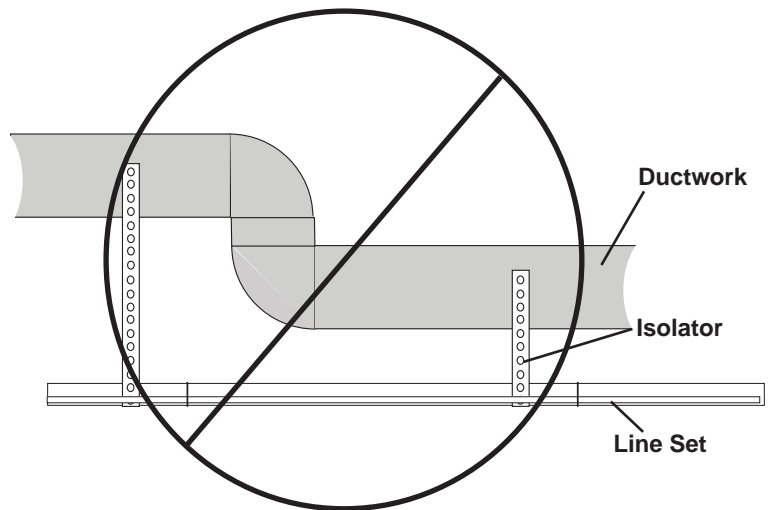

DO NOT hang line sets from ductwork

## Section 7. Refrigerant Line Brazing

### 7.1 Braze The Refrigerant Lines

**STEP 1** - Remove caps or plugs. Use a deburring tool to deburr the pipe ends. Clean both internal and external surfaces of the tubing using an emery cloth.

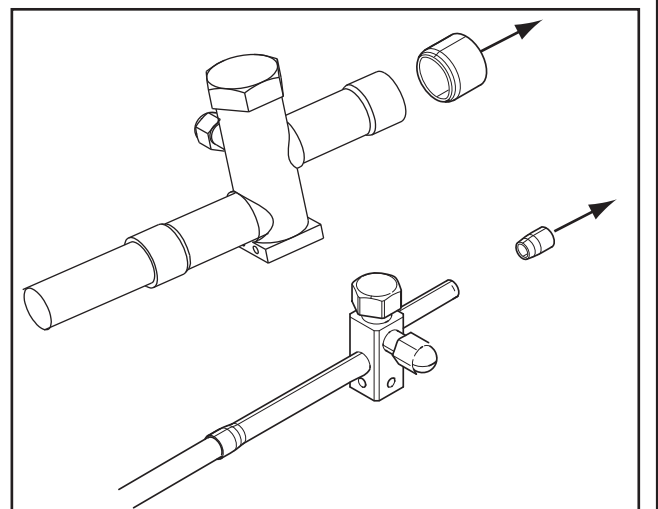



**STEP 2** - Remove the pressure tap cap from both service valves.

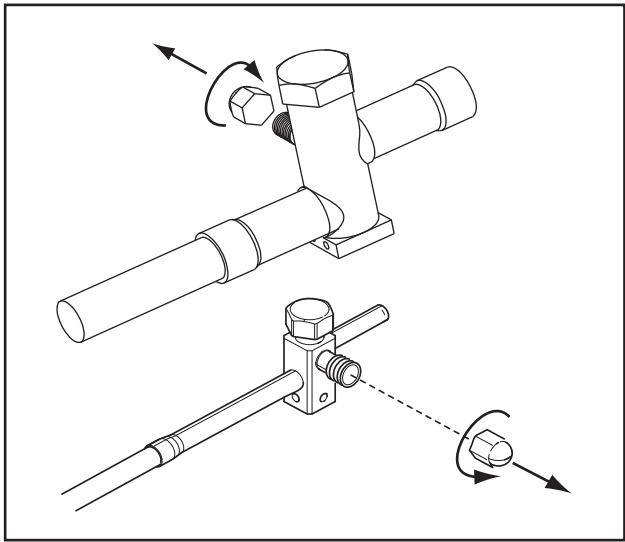

**STEP 3** - Purge the refrigerant lines and indoor coil with dry nitrogen.

This pipe must have a thimble

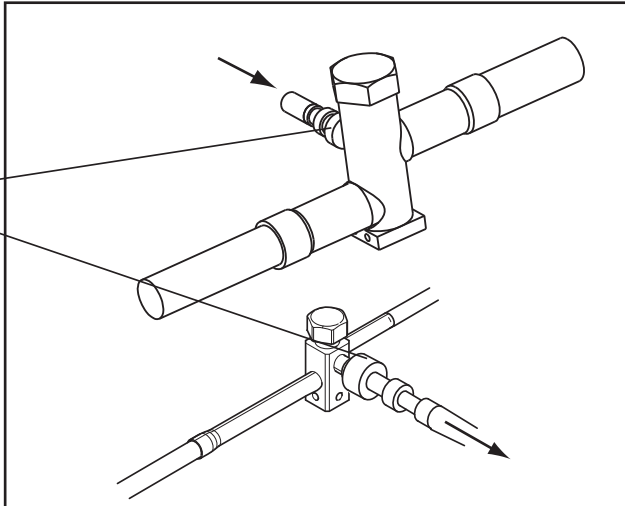

**STEP 4** - Wrap a wet rag around the valve body to avoid heat damage and continue the dry nitrogen purge.

Braze the refrigerant lines to the service valves.

Check liquid line filter drier's directional flow arrow to confirm correct direction of refrigeration flow (away from outdoor unit and toward evaporator coil) as illustrated. Braze the filter drier to the Liquid Line.

Continue the dry nitrogen purge. Do not remove the wet rag until all brazing is completed.

Important: Remove the wet rag before stopping the dry nitrogen purge.

**Note:** Install drier in Liquid Line.

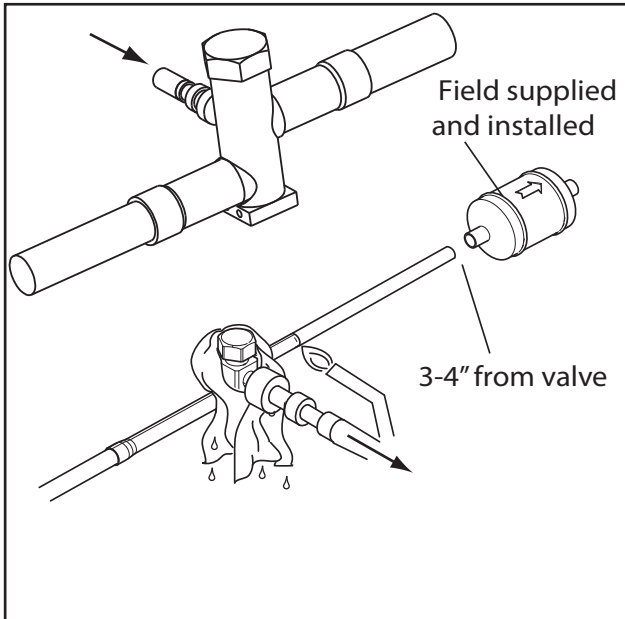

**STEP 5** - Replace the pressure tap caps after the service valves have cooled.

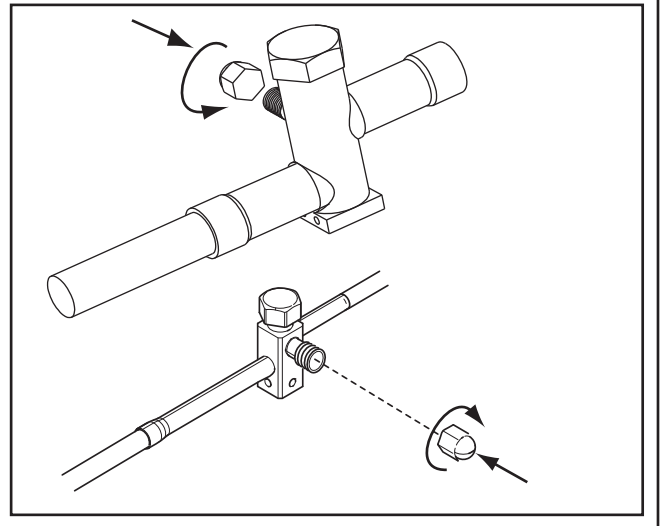

## Section 8. Refrigerant Line Leak Check

### 8.1 Check For Leaks

**STEP 1** - Pressurize the refrigerant lines and evaporator coil to 150 PSIG using dry nitrogen.

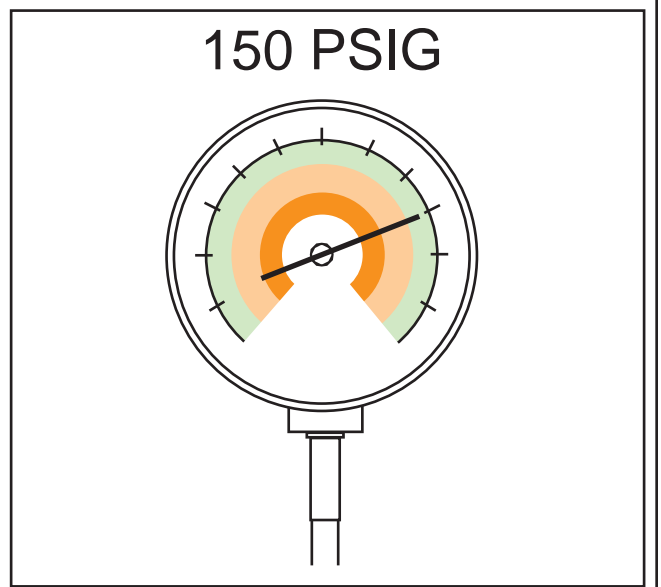

**STEP 2** - Check for leaks by using a soapy solution or bubbles at each brazed location.

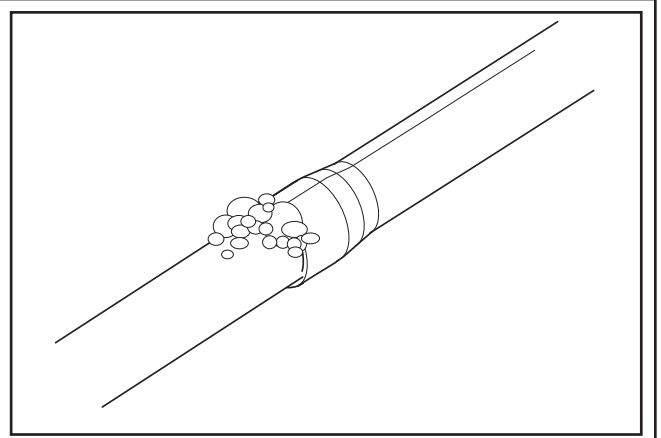

## Section 9. Evacuation

### 9.1 Evacuate the Refrigerant Lines and Indoor Coil

**Important:** Do not open the service valves until the refrigerant lines and indoor coil leak check and evacuation are complete.

**STEP 1-** Evacuate until the micron gauge reads no higher than 350 microns, then close the valve to the vacuum pump.

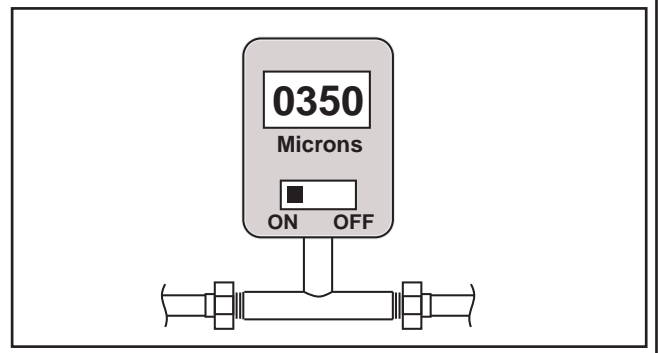

**STEP 2-** Observe the micron gauge. Evacuation is complete if the micron gauge does not rise above 500 microns in one (1) minute.

Once evacuation is complete blank off the vacuum pump and micron gauge, and close the valves on the manifold gauge set.

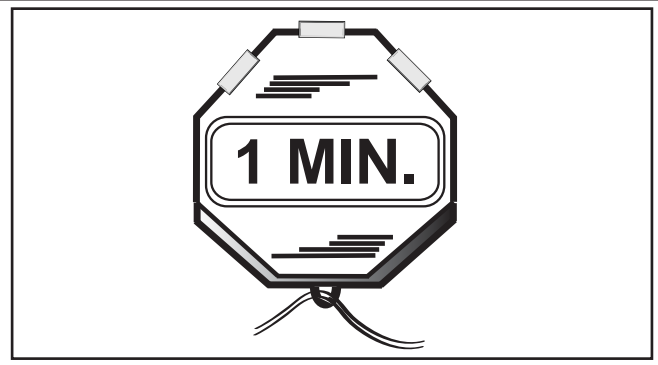

## Section 10. Service Valves

### 10.1 Open the Service Valves

#### **⚠ WARNING**

Extreme caution should be exercised when opening the Liquid Line Service Valve. Turn counterclockwise until the valve stem just touches the rolled edge. No torque is required. Failure to follow this warning will result in abrupt release of system charge and may result in personal injury and /or property damage.

**Important:** Leak check and evacuation must be completed before opening the service valves.

**Important:** The Suction Service Valve must be opened first BEFORE opening the Liquid Service Valve!

**STEP 1** - Remove service valve cap.

**STEP 2** - Fully insert hex wrench into the stem and back out counterclockwise until valve stem just touches the rolled edge (approximately five (5) turns.)

**STEP 3** - Replace the valve stem cap to prevent leaks. Tighten finger tight plus an additional 1/6 turn.

**STEP 4** - Repeat STEPS 1 - 3 for Liquid Service Valve.

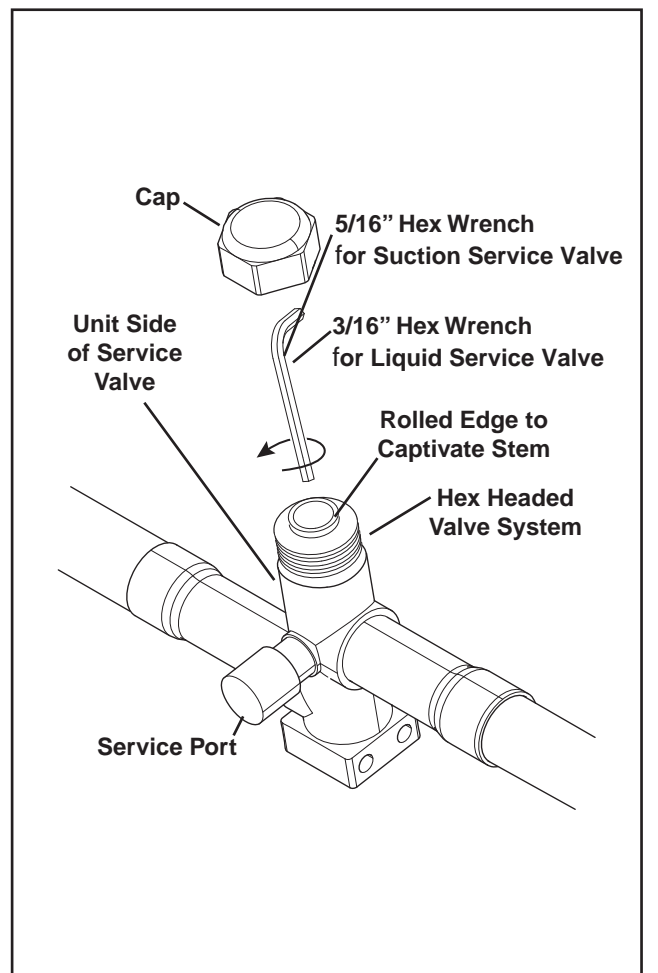

## Section 11. Electrical - Low Voltage

### 11.1 Low Voltage Maximum Wire Length

Table 11.1 defines the maximum total length of low voltage wiring from the outdoor unit, to the indoor unit, and to the thermostat.

Field provided bushing or strain relief is required at the low voltage wire entry point.

**Table 11.1**

24 VOLTS	
WIRE SIZE	MAX. WIRE LENGTH
18 AWG	150 Ft.
16 AWG	225 Ft.
14 AWG	300 Ft.

### 11.2 Low Voltage Hook-up Diagrams

#### Air Handler Hook-up Diagram

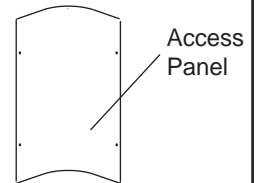
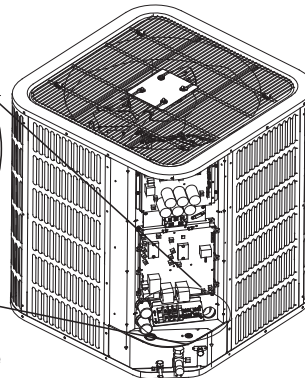
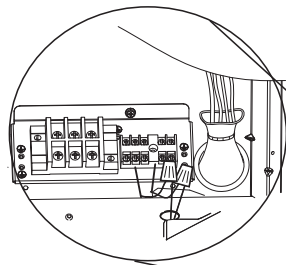
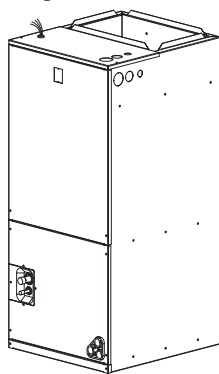

Low Voltage connection must be made inside the outdoor unit case.

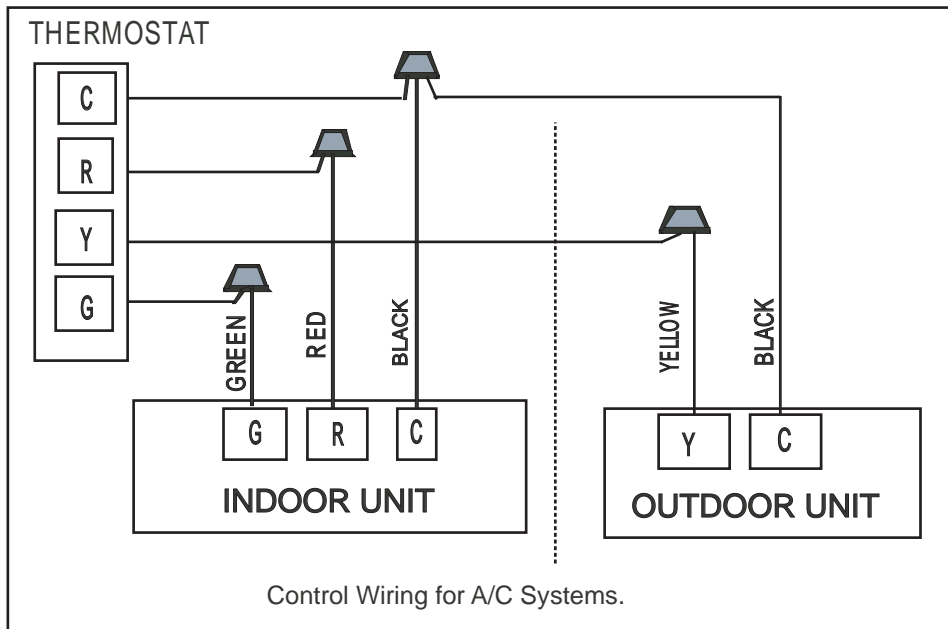

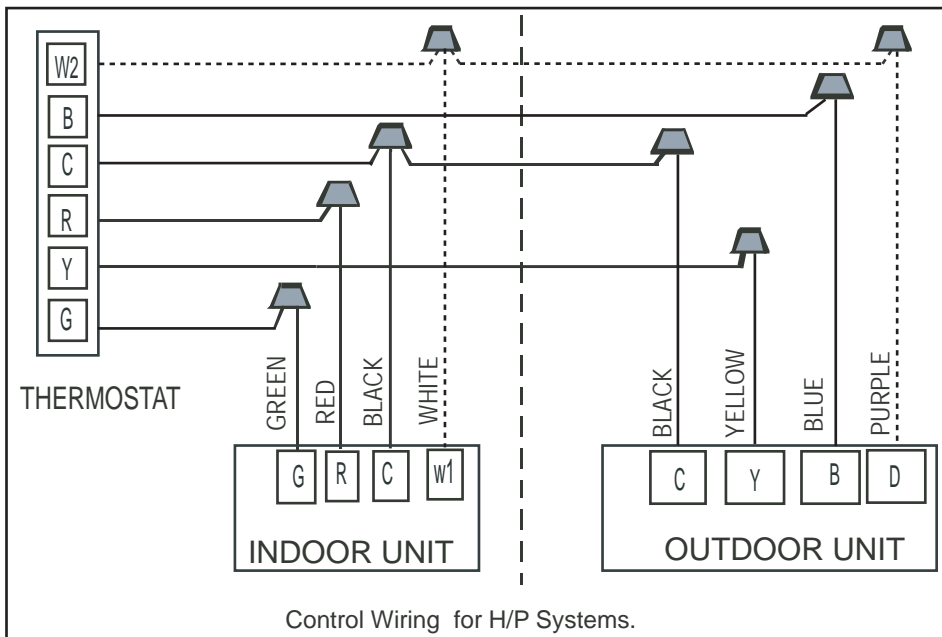

*Notes:*

1. Be sure power supply agrees with equipment nameplate.
2. Power wiring and grounding of equipment must comply with local codes.
3. Low voltage wiring to be No. 18 AWG minimum conductor.
4. "-----"The electric auxiliary heat connection.

## Section 12. Electrical - High Voltage

### 12.1 High Voltage Power Supply

#### **⚠ WARNING**

##### **LIVE ELECTRICAL COMPONENTS!**

During installation, testing, servicing, and troubleshooting of this product, it may be necessary to work with live electrical components. Failure to follow all electrical safety precautions when exposed to live electrical components could result in death or serious injury.

The high voltage power supply must agree with the equipment nameplate.

Power wiring must comply with national, state, and local codes.

Follow instructions on unit wiring diagram located on the inside of the control box cover and in the Service Facts document included with the unit.

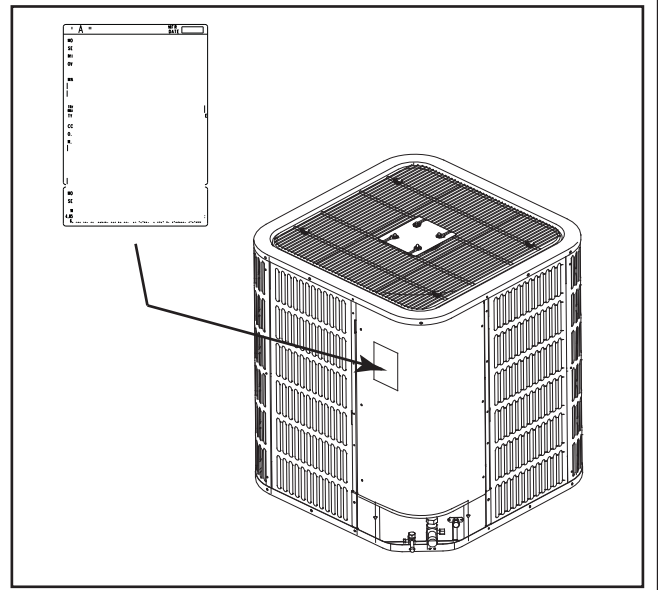

### 12.2 High Voltage Disconnect Switch

Install a separate disconnect switch at the outdoor unit.

Field provided flexible electrical conduit must be used for high voltage wiring.

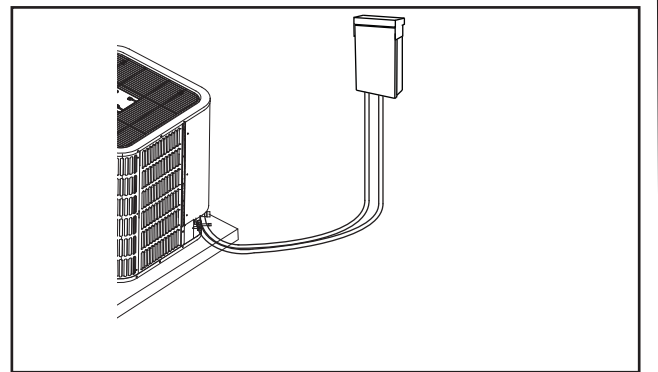

### 12.3 High Voltage Ground

Ground the outdoor unit per national, state, and local code requirements.

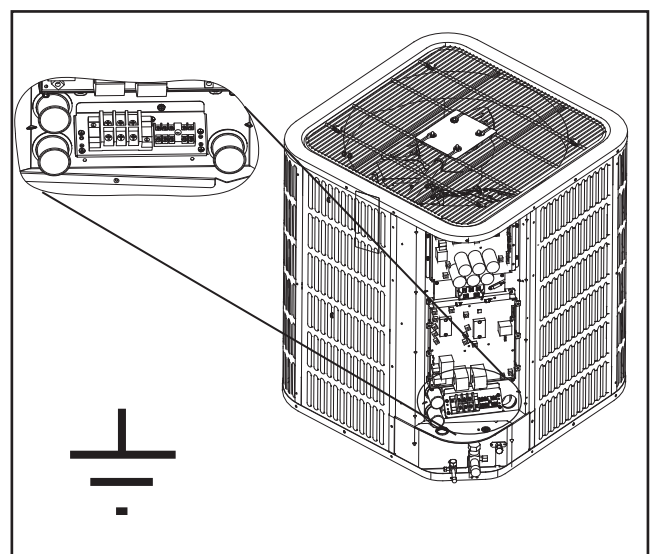

## Section 13. Start Up

### 13.1 System Start Up

**STEP 1** - Ensure Sections 7, 8, 9, 10, 11, 12, and 13 have been completed.

**STEP 2** - Set System Thermostat to OFF.

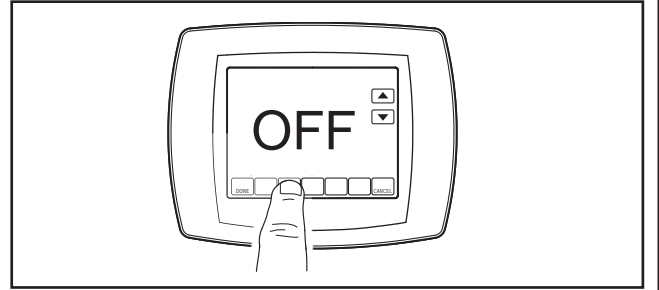

**STEP 3** - Turn on disconnect to apply power to the indoor and outdoor units.

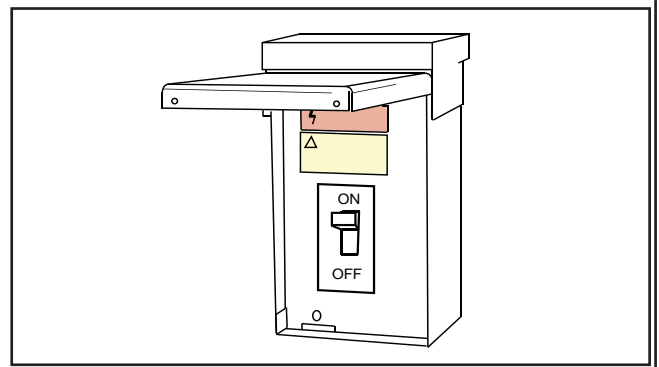

**STEP 4** - Wait five (5) minutes before moving to Step 5 if no crankcase heater accessory is used,

Wait one (1) hour before starting the unit if compressor crankcase heater accessory is used and the Outdoor Ambient Temperature is below 70 °F.



**STEP 5** - Set system thermostat to ON.

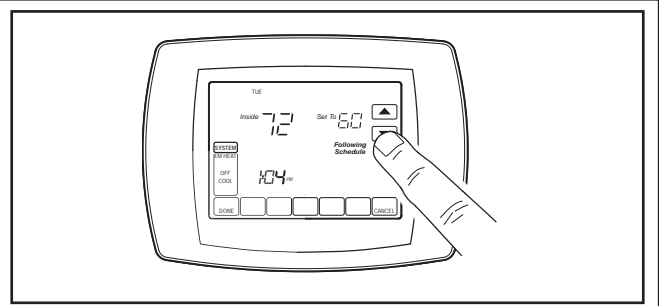



## Section 14. System Charge Adjustment

### 14.1 charging: weigh-In Method

weigh-In Method can be used for the Initial installation, or anytime a system charge is being replaced. weigh-In Method can also be used when power is not available to the equipment site or operating conditions (indoor/Outdoor temperatures) are not In range to verify with the subcooling charging method.

A	B	C
Model	Factory Charge	charge multiplier for interconnecting refrigerant tube length
All models	(The data on nameplate)	0.6 oz/ft

Note: The factory charge in the outdoor unit is sufficient for 15 feet of standard size interconnecting liquid line.

Table 19. New Installations — calculating charge using the weigh-In method

<ol style="list-style-type: none"> <li>1. Measure in feet the distance between the outdoor unit and the indoor unit and record on (Line 1). Include the entire length of the line from the service valve to the IDU.</li> <li>2. Enter the charge multiplier from column C.</li> <li>3. Multiply the total length of refrigerant tubing (Line 1) times the value on step 2. Record the resulting value.</li> <li>4. This is the amount of refrigerant to weigh-in prior to opening the service valves.</li> </ol>	<p>New Installation weigh-In Method worksheet</p> <p>1. Line Length (ft) _____</p> <p>2. value from Column C            x    _____</p> <p>3. Refrigerant((Step1-15) x Step2) = _____</p> <p>Note: If line length is Less than 15 feet , Refrigerant=0, don't charge.</p>
---	--

Table 20. Sealed-System Repairs — calculating charge using the weigh-In method.

<ol style="list-style-type: none"> <li>1. Measure in feet the distance between the outdoor unit and the indoor unit and record on (Line 1). Include the entire length of the line from the service valve to the IDU.</li> <li>2. Enter the charge multiplier from column C.</li> <li>3. Multiply the total length of refrigerant tubing (Line 1) times the value on (Line 2). Record the result on (Line 3) of the worksheet.</li> <li>4. Record the value in column B to Line 4 of the worksheet.</li> <li>5. Add the values from step 3, step 4, and record the resulting value on Line 5. This is the amount of refrigerant to weigh-in.</li> </ol>	<p>New Installation weigh-In Method worksheet</p> <p>1. Line Length (ft) _____</p> <p>2. value from Column C            x    _____</p> <p>3. (Step1-15) x step 2                =    _____</p> <p>4. Factory charge (column B) +    _____</p> <p>5. Refrigerant (steps 3+4)            =    _____</p> <p>Note: If line length is Less than 15 feet , Refrigerant=factory charge</p>
--	---

Note: The only mode approved for setting validating system charge is using Charging Mode-cooling. Outdoor Temperature must be between 55°F and 120°F with Indoor Temperature kept between 70°F and 80°F.

## 14.2 Subcooling charging and refrigerant adjustment in cooling (above 55 F outdoor temp.)

### STEP 1 - Check the outdoor ambient temperatures.

Subcooling (in cooling mode) is the only recommended method of charging above 55°F outdoor ambient temperatures.

Outdoor Temperature Above 55°F

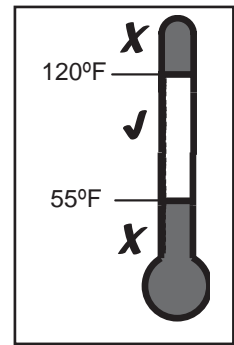

Outdoor Temp1

For outdoor ambient temperatures below 55°F, use weigh-in charge method.

Note: It is important to return in the spring or summer to accurately charge the system in the cooling mode when outdoor ambient temperature is above 55°F.

Outdoor Temperature Below 55°F

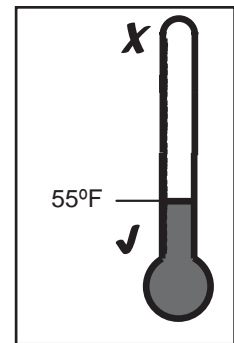

Outdoor Temp2

For best results the indoor temperature should be kept between 70°F to 80°F.

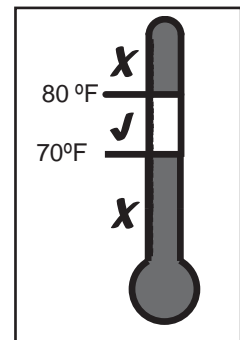

Indoor Temp

### STEP 2 - Ensure Sections 7, 8, 9, 10, and 13 have been completed.

### STEP 3 - Stabilize the system.

After starting the system in cooling mode, short press "FORCE" button, and "┆" symbol appears in 10 minutes, operate the system for a minimum of twenty (20) minutes.

**Important:** Whenever charge adjustment or expansion valve adjustment, if unit is running continuously, the system must be operated for a minimum of five (5) minutes, otherwise repeat step 3.



**STEP 4 - Calculate superheat value on suction valves(According to form )**

Measured Suction Line Temp. = \_\_\_\_\_ °F  
 Measured Suction Line Pressure = \_\_\_\_\_ PSIG  
 Calculate superheat value = \_\_\_\_\_ °F

Note: Make sure the superheat value of suction valve should be above 12°F, if the value is lower than this, indoor TXV should be adjusted. If the temperature is higher than 18°F, we suggest to adjust indoor TXV. Repeat the steps above.

(If to adjust TXV, steps of adjustment are shown on separate sheet, and repeat this step.)

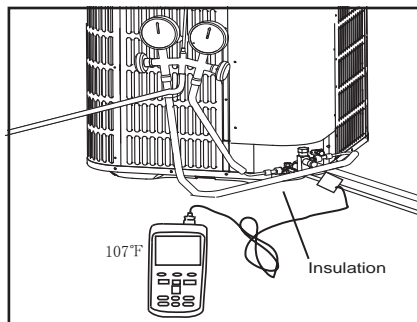

R-410A REFRIGERAN CHART								
SUCTION TEMP (°F)	FINAL SUPERHEAT (°F)							
	8	10	12	14	16	18	20	22
	SUCTION GAGE PRESSURE (PSI)							
40	101	97	93	89	86	82	78	75
42	105	101	97	93	89	86	82	78
44	110	105	101	97	93	89	86	82
46	114	110	105	101	97	93	89	86
48	118	114	110	105	101	97	93	89
50	123	118	114	110	105	101	97	93
52	128	123	118	114	110	105	101	97
54	133	128	123	118	114	110	105	101
56	138	133	128	123	118	114	110	105
58	143	138	133	128	123	118	114	110
60	148	143	138	133	128	123	118	114
62	153	148	143	138	133	128	123	118
64	159	153	148	143	138	133	128	123
66	164	159	153	148	143	138	133	128
68	170	164	159	153	148	143	138	133
70	176	170	164	159	153	148	143	138
72	182	176	170	164	159	153	148	143

**STEP 5 - Calculate subcooling value on liquid valves(According to form )**

Measured liquid Line Temp = \_\_\_\_\_ °F  
 Measured liquid Line Pressure = \_\_\_\_\_ PSIG  
 Calculate subcooling value = \_\_\_\_\_ °F

Note: If calculated subcooling value is lower than the design subcooling value, please add refrigerant. Repeat the steps above.

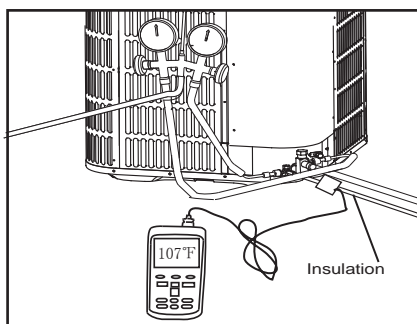

R-410A REFRIGERAN CHART								
SUCTION TEMP (°F)	FINAL SUBCOOLING (°F)							
	6	7	8	9	10	11	12	13
	LIQUID GAGE PRESSURE (PSI)							
55	173	176	179	182	185	188	191	195
60	188	191	195	198	201	204	208	211
65	204	208	211	215	218	221	225	229
70	221	225	229	232	236	239	243	247
75	239	243	247	251	255	259	262	266
80	259	262	266	270	275	279	283	287
85	279	283	287	291	295	300	304	309
90	300	304	309	313	318	322	327	331
95	322	327	331	336	341	346	351	355
100	346	351	355	360	365	370	376	381
105	370	376	381	386	391	397	402	407
110	397	402	407	413	418	424	430	435
115	424	430	435	441	447	453	459	465
120	453	459	465	471	477	483	489	496
125	483	489	496	502	508	515	521	528

Model	24	36	48	60
Design subcooling	10°F	10°F	8°F	7°F

**STEP 6** - Adjust refrigerant level to attain proper gage pressure.

**Add refrigerant** if the design subcooling is lower than the chart value.

1. Connect gages to refrigerant bottle and unit as illustrated.
2. Purge all hoses.
3. Open bottle.
4. Stop adding refrigerant when subcooling matches the charging chart Final Subcooling value.

**Recover refrigerant** if the subcooling is higher than the chart value.

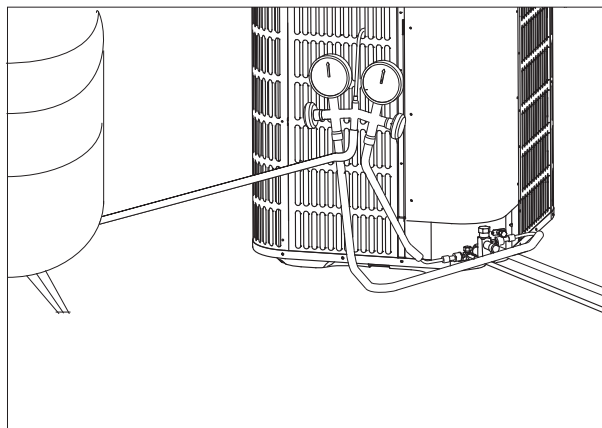

**STEP 7** - Stabilize the system.

1. Wait 5 minutes for the system condition to stabilize between adjustments.

**Note:** When the subcooling match the chart, the system is properly charged.

2. Remove gages.
3. Replace service port caps to prevent leaks. Tighten finger tight plus an additional 1/6 turn.



**STEP 8** - Record System Information for reference.

Record system pressures and temperatures after charging is complete.

Outdoor model number = \_\_\_\_\_

Measured Outdoor Ambient = \_\_\_\_\_ °F

Measured Indoor Ambient = \_\_\_\_\_ °F

Measured Liquid Line Temp = \_\_\_\_\_ °F

Measured Suction Line Temp = \_\_\_\_\_ °F

Liquid Gage Pressure = \_\_\_\_\_ PSIG

Suction Gage Pressure = \_\_\_\_\_ PSIG



#### 4、Defrost description (Heat Pump only)

● The demand defrost control measures the coil temperature with a sensor located on the heat pump coil. A second sensor located outside the outdoor coil is used to measure outdoor ambient temperature. The demand of defrost is computed by the coil temperature and outdoor ambient temperature, also, by the running time and outdoor ambient temperature, by the running time and high pressure when high pressure is lower than a certain value.

● Enter defrosting

The following 3 situations were determined to enter defrosting:

- ① Outdoor coil temp.  $T_3 < 34^\circ\text{F}$ , and satisfy a certain correspondence of  $T_4$  ambient temp.
- ② When operating time accumulates to a certain value. For different Ambient Temp.  $T_4$ , time settings are different, when  $T_4 < -23^\circ\text{F}$ , cumulative time is 4h, when  $T_4 \geq -23^\circ\text{F}$  and  $T_4 < 42^\circ\text{F}$  the cumulative time is 2h.
- ③ When high pressure lasts low, the situation that the saturation temperature of high pressure lower than  $82^\circ\text{F}$  lasts for 20 min determines to enter defrosting.

● Dial code SW5:

Defrosting quit

According to outdoor coil temp.  $T_3$  is up to  $64^\circ\text{F}$  and lasts for 1 min. Or defrosting time is up to 8 min.

● Defrosting control choice

Dial code SW5 can adjust and set the time that enters and quits defrosting

In general, adjust dial code to ON can enhance the ability of defrosting.

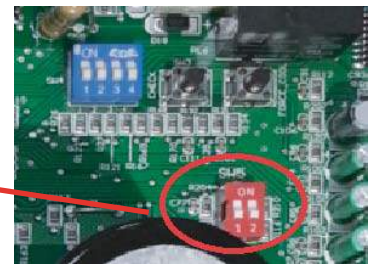
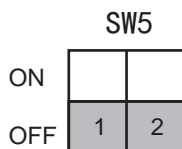

Defrosting choice	SW5-1	SW5-2	Remarks
ON	Operating time is reduced by 10%	Defrosting extended for 60 seconds	
OFF	Normal	Normal	Default
Remarks	Enter defrost	Quit defrost	

● Manual defrosting (Heat Pump only)

1. System must be running with demand from the thermostat.
2. Forced Defrost Test can be initiated when the running time must be longer than 8 minutes in heat mode only.
3. Press "FORCE" key for 6 seconds to begin forced defrost.
4. Execute Forced Defrost. (Please wait 40 seconds before defrost)
5. When test begins, the displays will display "dF". (the display procedure: the running speed of 40S-- "dF"-- the running speed)
6. Forced Defrost Test is complete automatically, and the display is the running speed.
7. If Forced Defrost is needed again, you can repeat step 3 after 5 minutes.

## 5. Compressor Crankcase heater description

Refrigerant migration during the off cycle can result in a noisy start up. Add a crankcase heater to minimize refrigeration migration, and to help eliminate any start up noise or bearing "wash out".

All heaters must be located on the lower half of the compressor shell. Its purpose is to drive refrigerant from the compressor shell during long off cycles, thus preventing damage to the compressor during start-up.

At initial start-up or after extended shutdown periods, make sure the heater is energized for at least 12 hours before the compressor is started. (Disconnect switch on and wall thermostat off.)

- The crankcase heating start condition:

Start if crankcase heating zone can satisfy one of the three conditions,

1. First time to power on and  $T5 > 104^{\circ}\text{F}$
2. In process of defrosting
3. Compressor stops running for 4h and the outdoor ambient temp.  $T4$  once lower than  $50^{\circ}\text{F}$  or  $T5 < 104^{\circ}\text{F}$  .

- The crankcase heating stop must meet condition:

Air discharge temp.  $T5 \geq 113^{\circ}\text{F}$

## 6. Reversing valve introduction (heat pump only)

- Reversing valve energizes at the heating conditions, and cut off at the cooling condition.

## 7. Protection function introduction

- Outdoor coil temperature protection( $T3$ )

$T3 > 143.6^{\circ}\text{F}$ , compressor stop working;  $T3 < 129.2^{\circ}\text{F}$ , compressor start working.

- Ambient temperature protection( $T4$ ) (Cooling only system  $T4 = T3$ )

When  $50^{\circ}\text{F} \leq T4 < 140^{\circ}\text{F}$ , the units can work at the cooling condition.

When  $-4^{\circ}\text{F} \leq T4 < 86^{\circ}\text{F}$ , the units can work at the heating condition.

When  $T4 < 6.8^{\circ}\text{F}$ , If the electrical heater kit is installed in the indoor unit, the outdoor unit would provide a signal to drive up the heater.

- Discharge temperature protection( $T5$ )

When discharge temp.  $> 239^{\circ}\text{F}$ , the compressor will stop at the cooling condition.

When discharge temp.  $< 194^{\circ}\text{F}$ , the compressor will restart at the cooling condition.

When discharge temp.  $> 221^{\circ}\text{F}$ , the compressor will stop at the heating condition.

When discharge temp.  $< 167^{\circ}\text{F}$ , the compressor will restart at the heating condition.

- High pressure protection (HPS)

When high pressure  $> 580$  PSIG, the compressor and outdoor fan will stop.

When high pressure  $< 435$  PSIG, the compressor and outdoor fan will restart.

- Low pressure protection(PT)

Low pressure  $< 43.5$  PSIG lasting for 5 min in cooling model, the compressor and outdoor fan will stop. System will run again after 6 minutes.

- Module temperature protection (TF)

When  $TF > 176^{\circ}\text{F}$ , the compressor and outdoor fan will stop.

When  $TF < 145^{\circ}\text{F}$ , the compressor and outdoor fan will restart.



## 8. Fault code table

CODE	FAULT DESCRIPTION
E4	Temperature sensor fault(T3 /T4/T5/TF)
E5	High/low voltage protection
E6	DC fan motor fault
Eb	System lockup, 2 times(E6),protection in 10 minutes
E7	Compressor discharge sensor(T5) is seated fault
E9	EEPROM fault
H0	Communication fault in main control chip
H3	3 times (P3) protection in 120 minutes,system lockup
H4	3 times (P6) protection in 60 minutes,system lockup
H5	5 times (P2) protection in 100 minutes,system lockup
H6	3 times (P4) protection in 100 minutes,system lockup
H8	Pressure transducer(PT) short or open fault
Hb	High pressure(PT) protection in Heating
HH	2 times(PH) protection in 200 minutes,system lockup
P0	The module radiator temperature (TF)protection
P1	High pressure switch(HPS) protection
P2	Low pressure (PT) Protection
P3	Compressor over current protection
P4	High compressor discharge temperature(T5) protection
P5	High condensor coil temp. (T3) protection
P6	IPM module protection
P8	Hurricane protection of the DC fan motor
PH	Low discharge superheat protection
PC	Reversing valve fault protection
F1	High pressure switch(HPS) fault
F3	5 times (P5) protection in 180 minutes,system lockup
F4	3 times(P0) protection in 120 minutes,system lockup
F5	5 times(Hb) protection in 180 minutes,system lockup
C3	Condensor coil sensor(T3) is seated fault in cooling
C4	3 times(C3) protection in 120 minutes,system lockup
C5	2 times(E7) protection in 180 minutes,system lockup
C6	2 times(PC) protection in 180 minutes,system lockup
CE	5 times (P1) protection in 150 minutes,system lockup
L0-L9	IPM module protection or frequent power on/off
┣	Indication under charge model
L	Running indication under T3 limited condition
D	Running indication under T5 limited condition
P	Running indication under compressor ratio limited condition
F	Running indication under Tf limited condition
C	Running indication under current limited condition
U	Running indication under low voltage limited condition
H	Running indication under high pressure(PT) limited condition in heating
A	Running indication under return oil model
dF	Running indication under defrost model

## 9. Parameter point check table

- 1、 Shift to display content of data code pipe when pressing point check key shortly(check key). Display the next set of data when press the key once. The display content is accordance with the sequence.
- 2、 There're 3 digits for LED. The first digit is sequence(only display units digit, recycling display), the second and third digits are values. For example, the 8th item is operating low pressure saturation temperature. The 11th item is operating low pressure. For detailed meanings, please refer to the point check table.
3. After staying for 20s, it will recover to the normal status display
- 4、 For normal status display, the last 2 digits of nixie tube will display ambient temp when the unit is in standby status(the first nixie tube has no display). During operating, last 2 digits of nixie tube will display operating frequency.(If there's system protection, the first digit of nixie tube will display status code, details for code meaning, please refer to the Fault code table )

No.	Point check content	Example	Remark
0	Outdoor unit capacity	C3	Model+RT
1	Outdoor unit mode	2	0 standby, 2 cooling, 3 heating
2	Outdoor unit set compressor speed		
3	opening of EXV		Actual value
4	T3(outdoor coil temp.)		
5	T4 (outdoor ambient temp.)		
6	T5(compressor discharge temp.)		
7	Reserved		
8	Te (evaporating temp.)		
9	Tc (condensing temp.)		
10	Tf (module temp.)		
11	Pe (evaporating pressure)		Actual value MPa x10
12	Pc (evaporating pressure)		Actual value MPa x10
13	Compressor discharge superheat		
14	Reserved		
15	Reserved		
16	compressor current		
17	Reserved		
18	Fan speed		
19	Reserved		
20	Reserved		
21	Reserved		
22	Reserved		
23	The last time Fault code		
24	Software version		
25	Remark"--"		

For 24/36k model

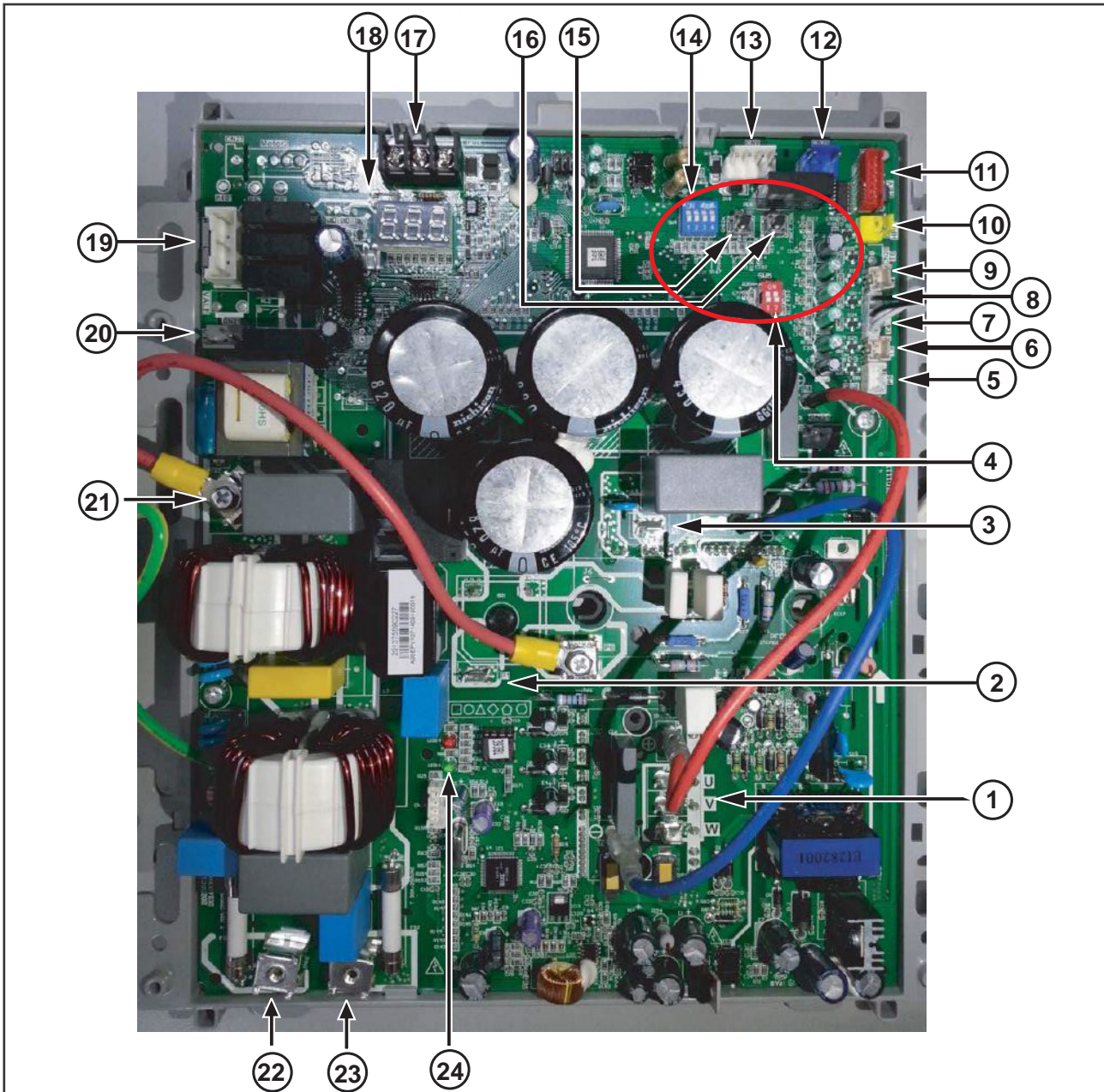

Function description for the corresponding position

No.	Content	No.	Content
1	Compressor iring terminal	13	Temp. controller connecting port
2	Reactor wiring terminal(connect a reactor between 2 and 3)	14	Function dial code SW4
3	Reactor wiring terminal(connect a reactor between 2 and 3)	15	Spot check button
4	Defrosting function dial code SW5	16	Forced operation button
5	Pressure transducer port	17	Reserved
6	Air discharge temp.sensor port	18	Nixie tube display
7	Outdoor temp.sensor port(HP only)	19	Fan control port
8	Condenser temp.sensor port	20	Crankcase heating zone control terminal
9	Radiator temp.sensor port	21	Short wire
10	High pressure switch port	22	Power supply connecting terminal
11	EXV drive port(HP only)	23	Power supply connecting terminal
12	Reversing valve port	24	Indicator lamp



For 48/60k model

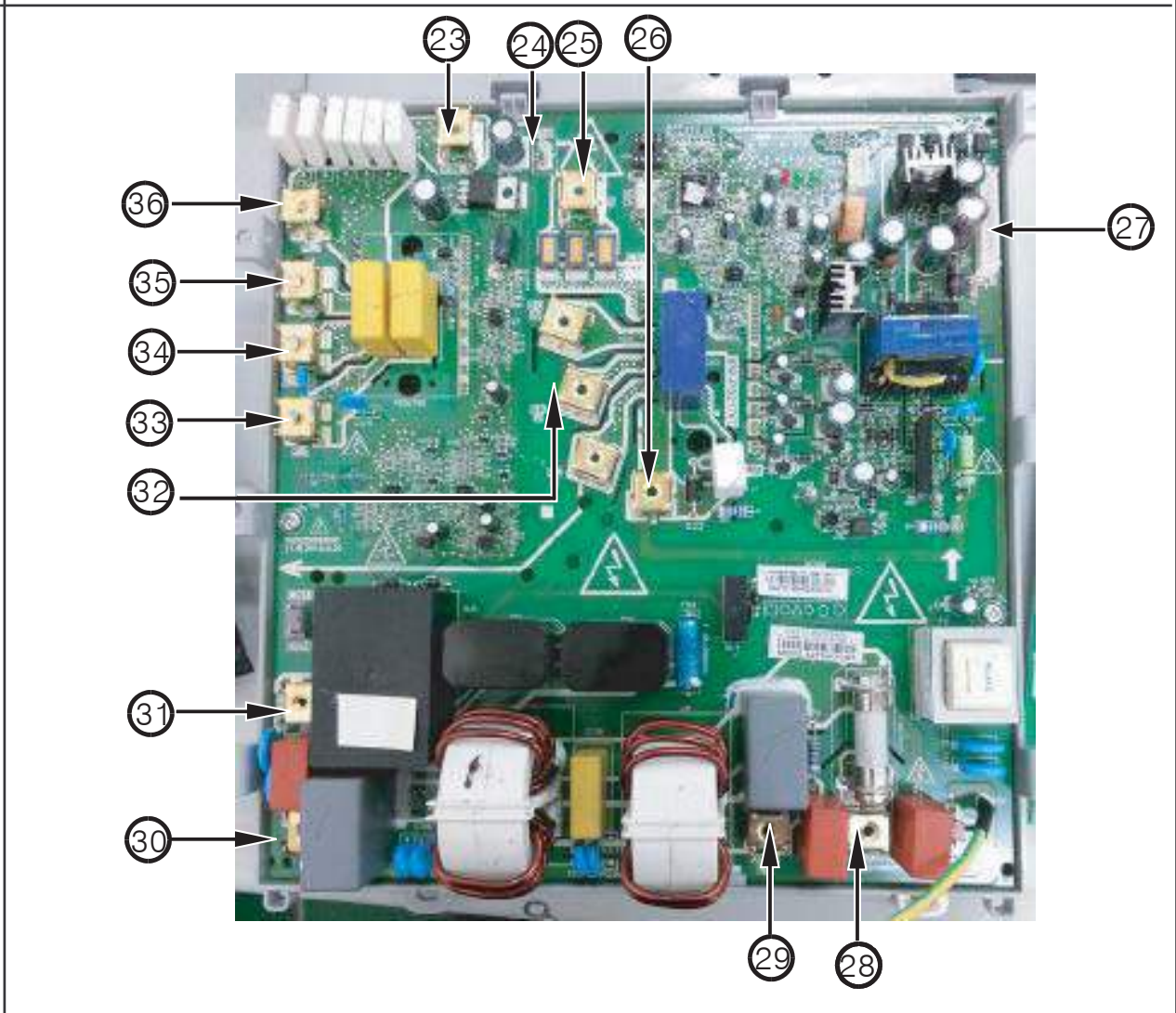
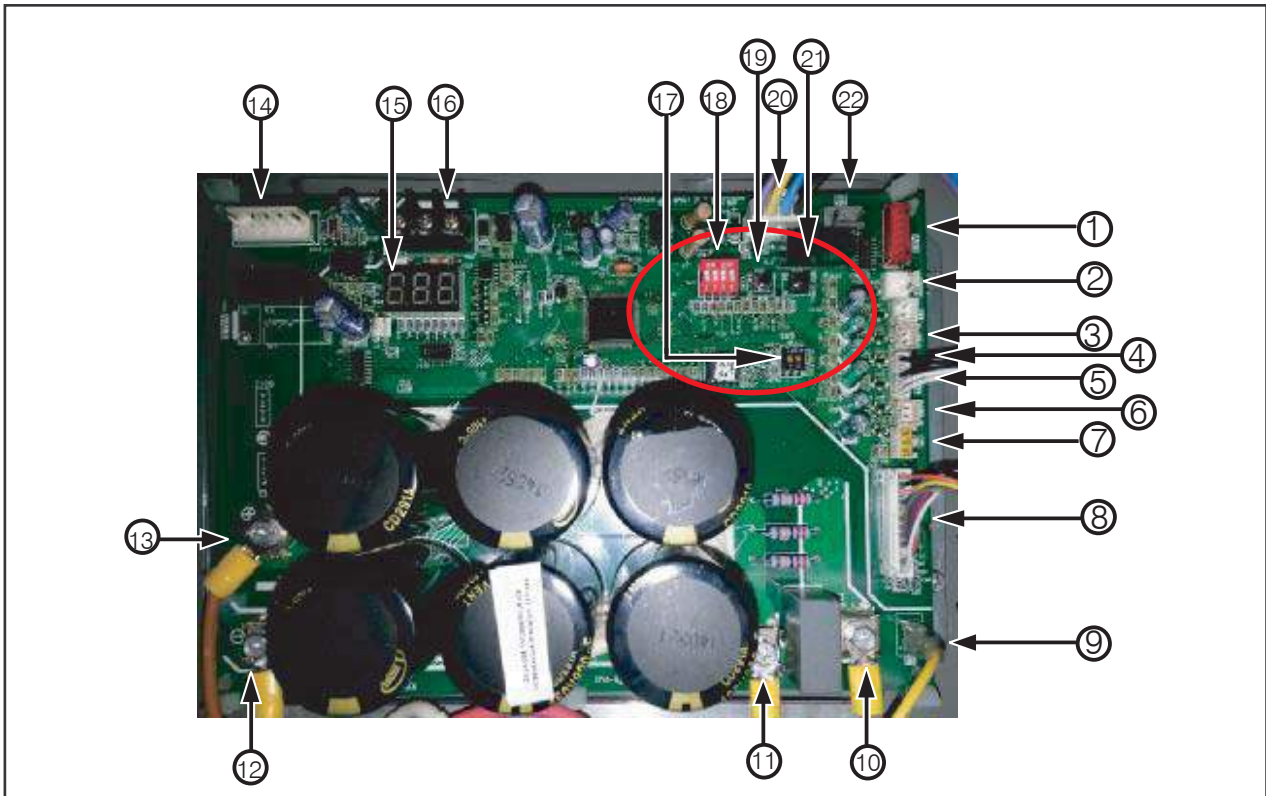

## Function description for the corresponding position (For 48/60k model)

No.	Content	No.	Content
1	EXV driving port (HP only)	19	Point check button
2	High pressure switch port	20	Temp. controller connection port
3	Radiator temp. sensor port	21	Forced operation button
4	Condenser temp. sensor port	22	4-way valve port (HP only)
5	Outdoor temp. sensor port (HP only)	23	Connect the cathode of the rectifier bridge
6	Air discharge temp. sensor port	24	DC motor driving source(15V-P2)
7	Pressure transducer	25	The voltage between 25 and 26 is 380Vdc (Compressor is running )
8	Connection wire port between main boards	26	The voltage between 25 and 26 is 380Vdc (Compressor is running)
9	DC motor driving source(15V-P2)	27	Connection wire port between main boards
10	The voltage between 10 and 11 is 380Vdc (Compressor is running)	28	AC power supply input port
11	The voltage between 10 and 11 is 380Vdc (Compressor is running)	29	AC power supply input port
12	The voltage between 12 and 13 is 380Vdc (Compressor is running)	30	AC power supply output port
13	The voltage between 12 and 13 is 380Vdc (Compressor is running)	31	AC power supply output port
14	DC motor control port	32	Compressor connection terminal
15	Nixie tube display	33	The voltage between 33 and 36 is 380Vdc (Compressor is running )
16	Reserved	34	Reactor L1 wiring terminal
17	Defrosting function dial code SW5	35	Reactor L2 wiring terminal
18	Function dial code SW4	36	The voltage between 33 and 36 is 380Vdc (Compressor is running)

## Troubleshooting

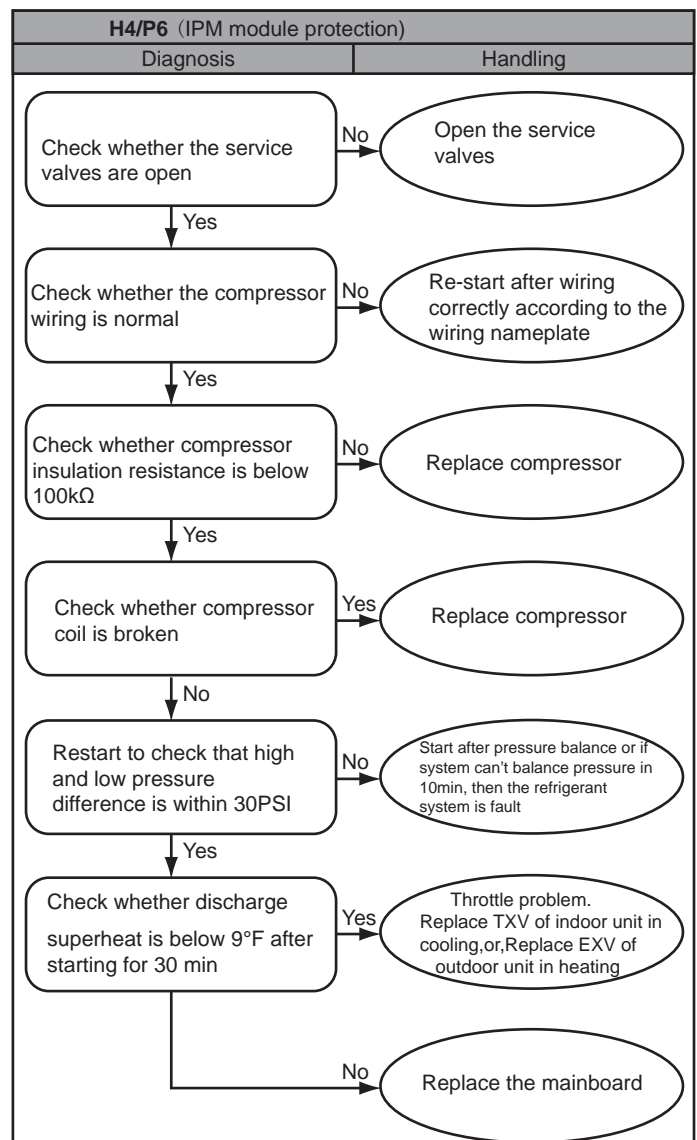
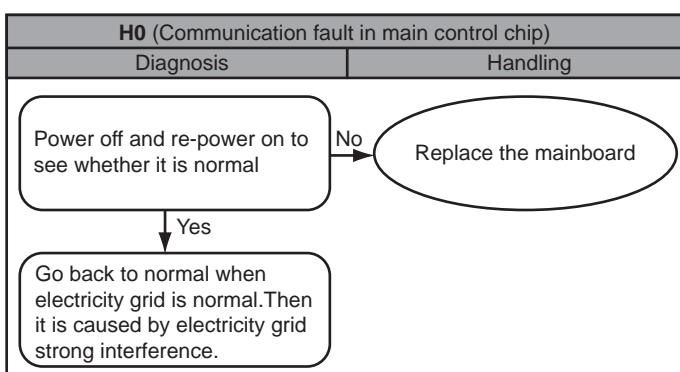
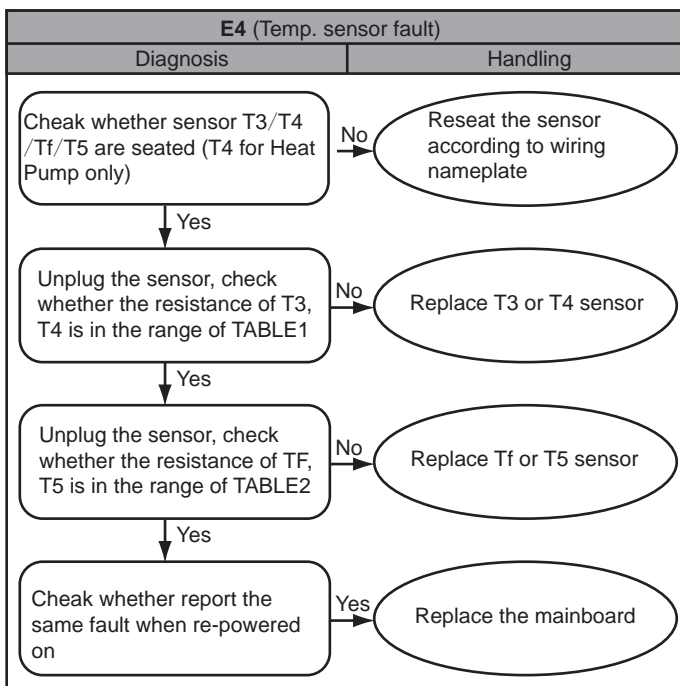

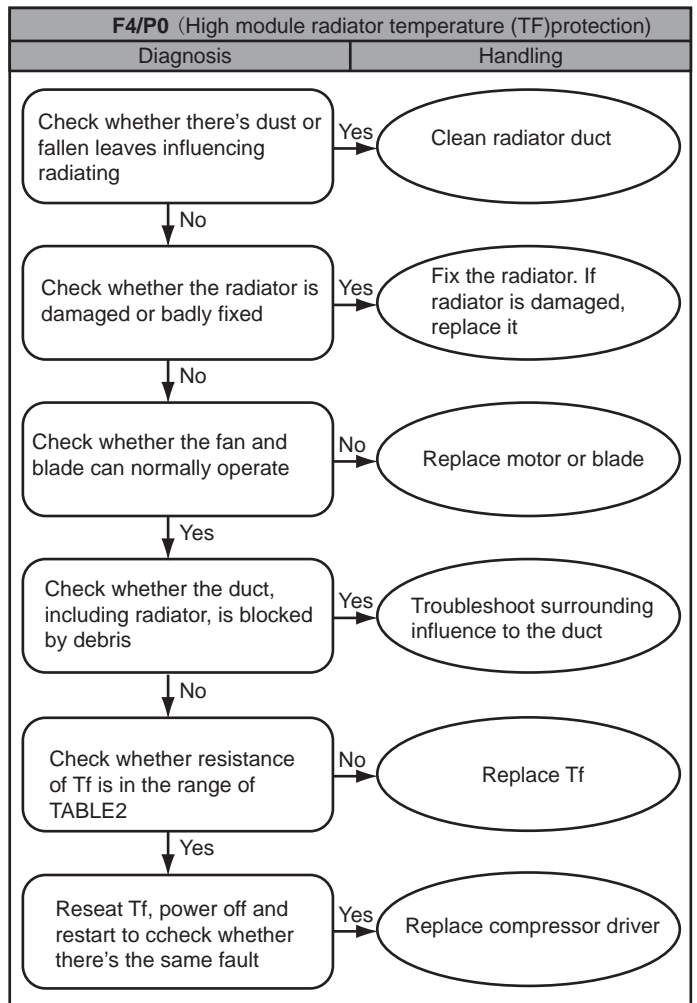
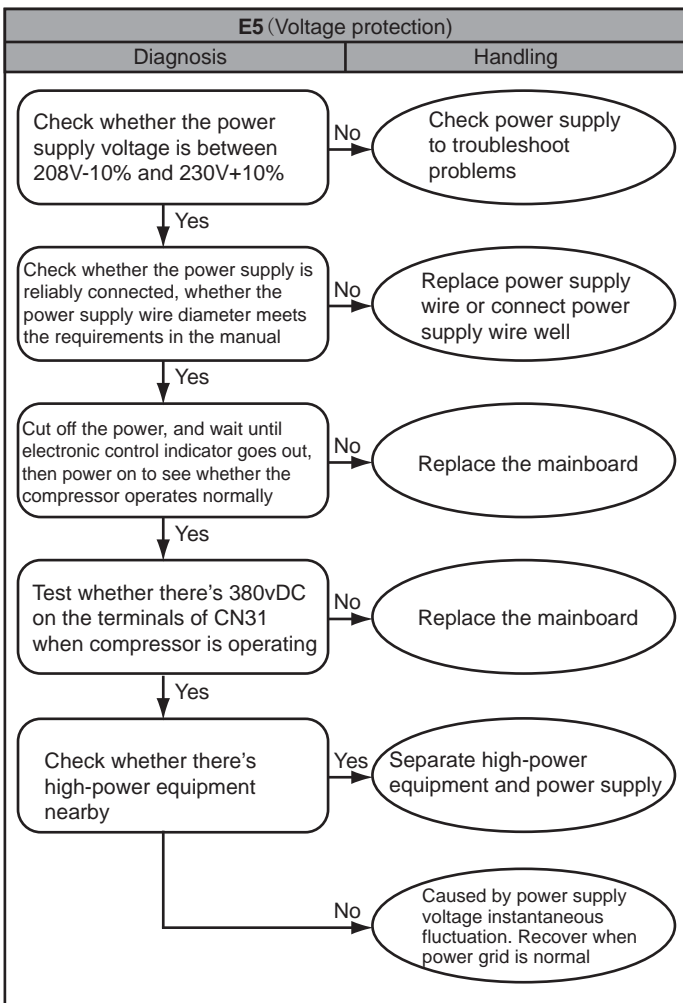
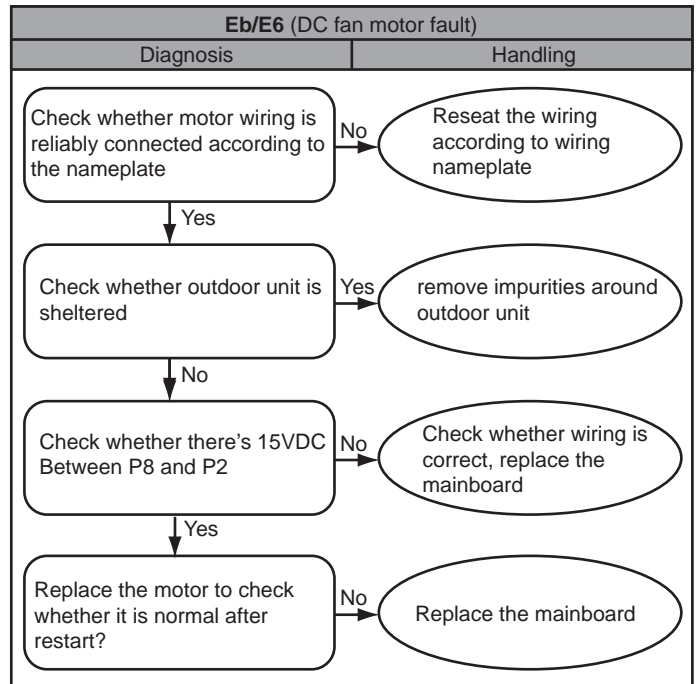
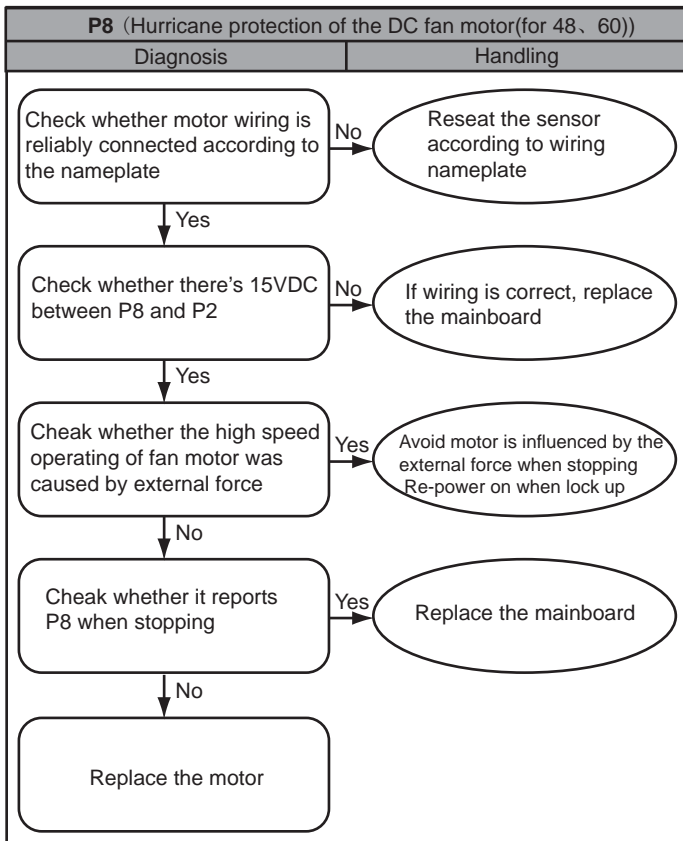

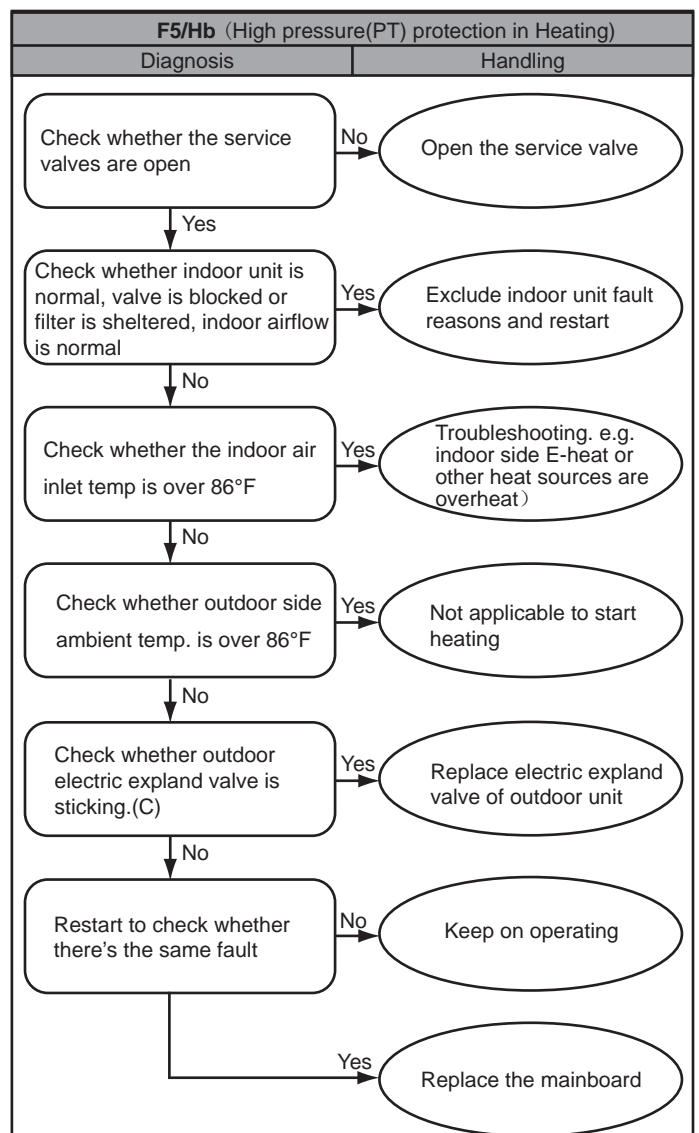
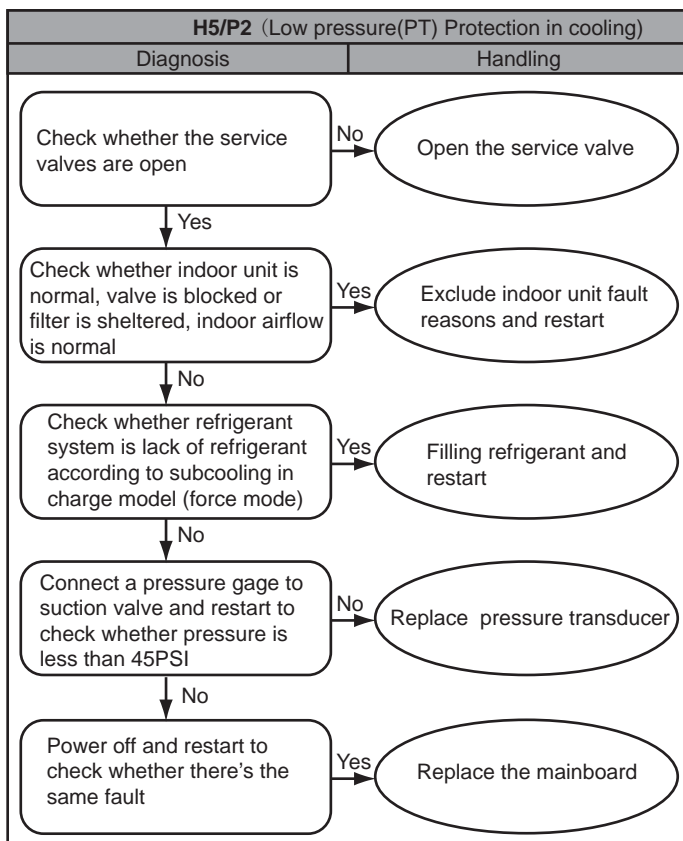
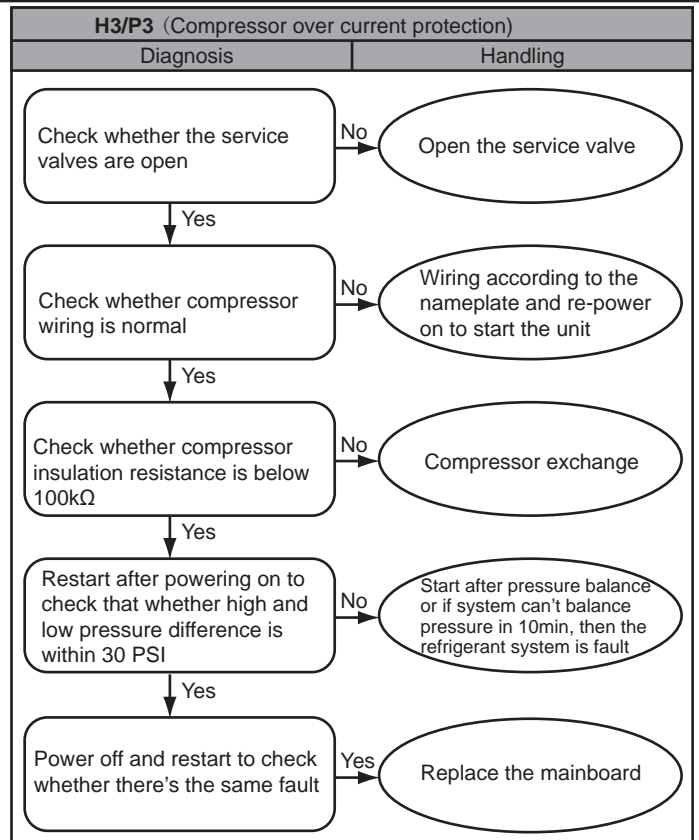
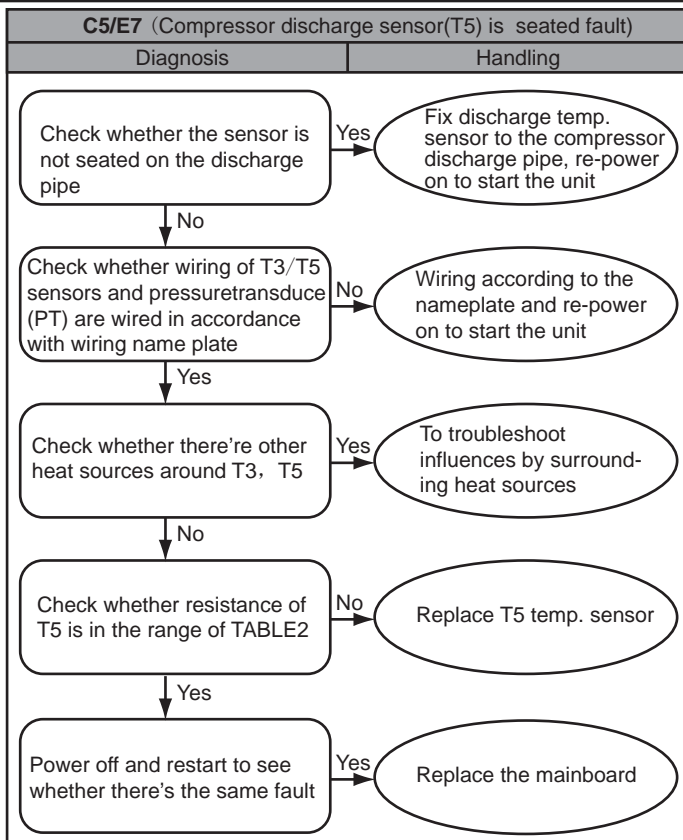



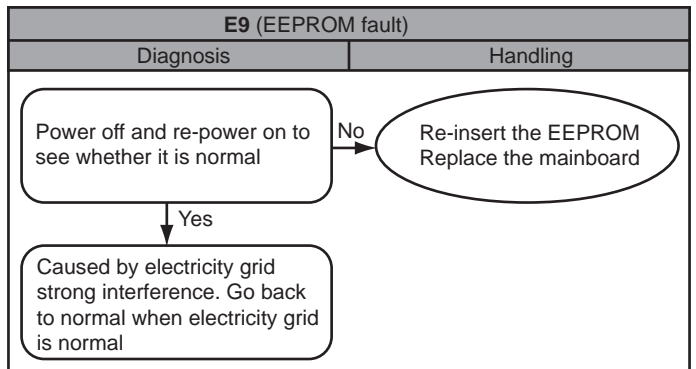
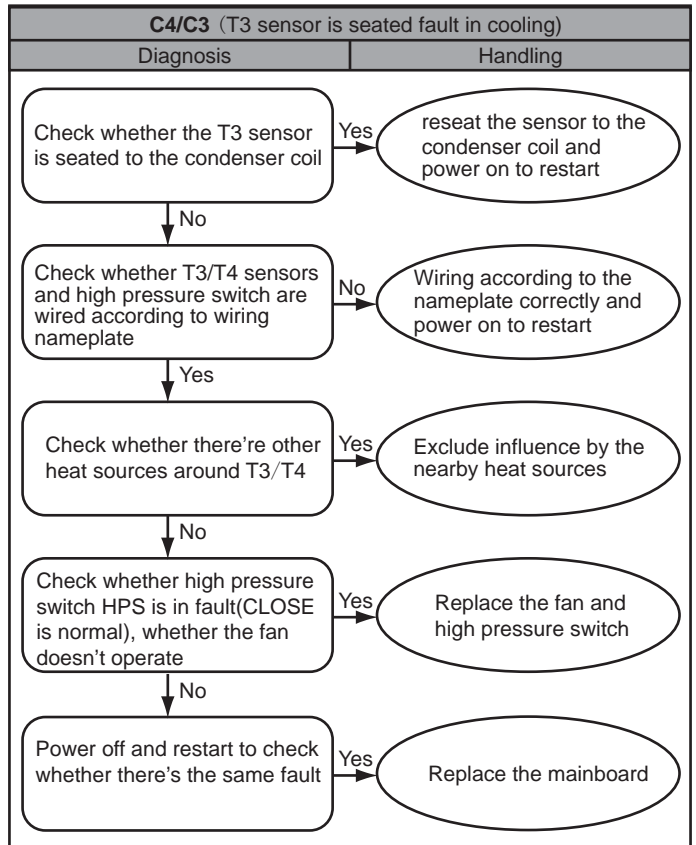
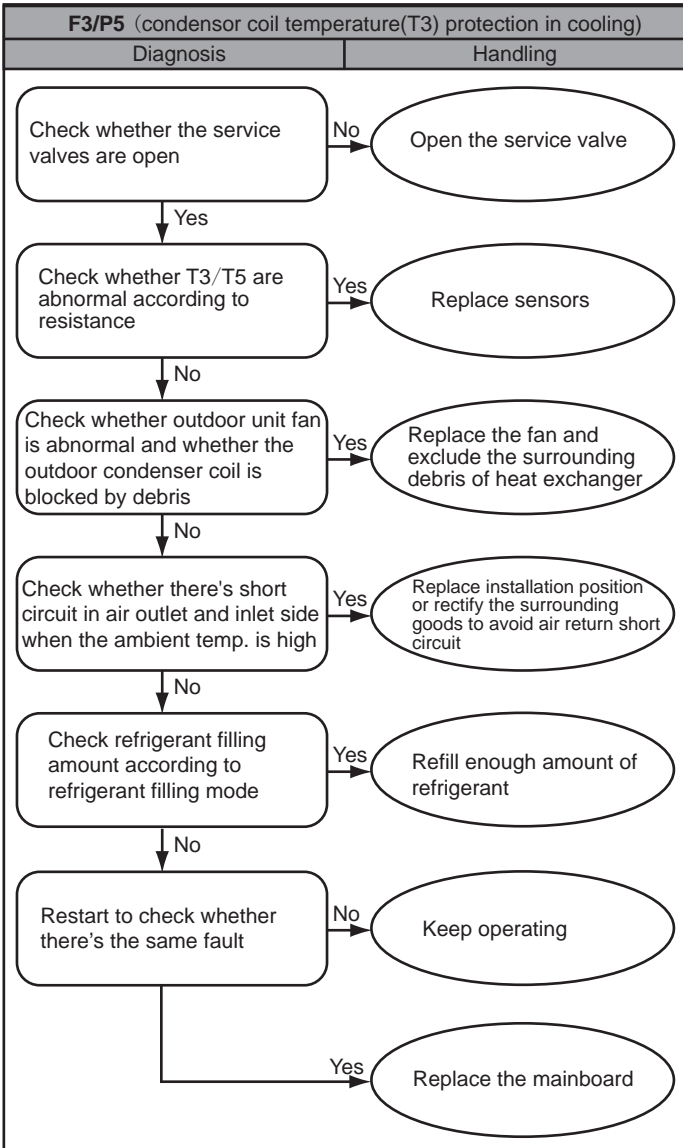
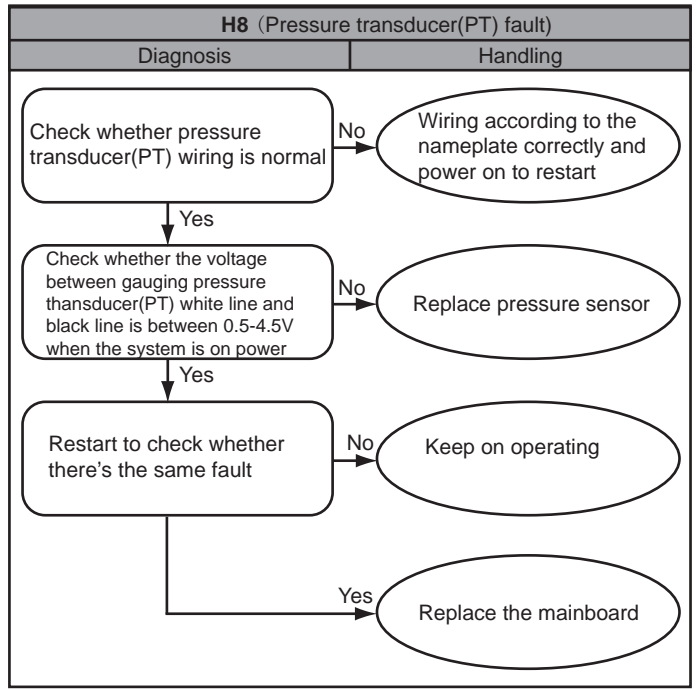
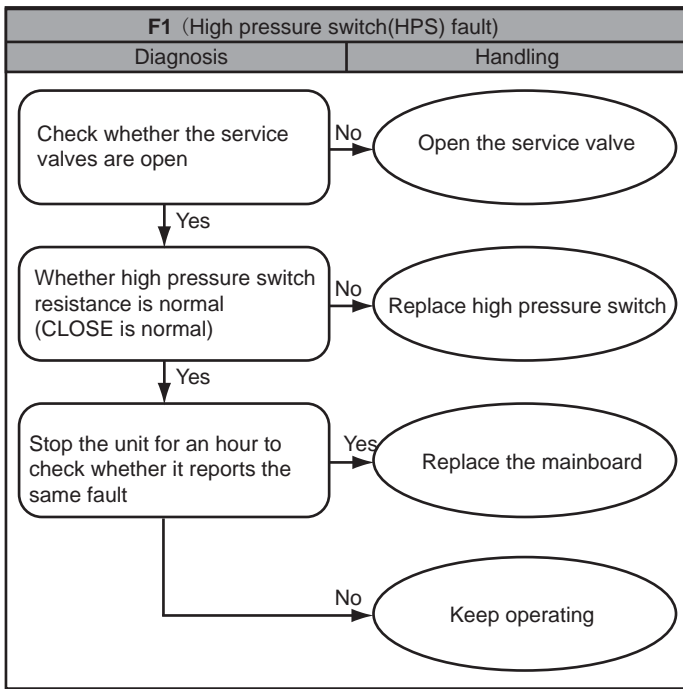

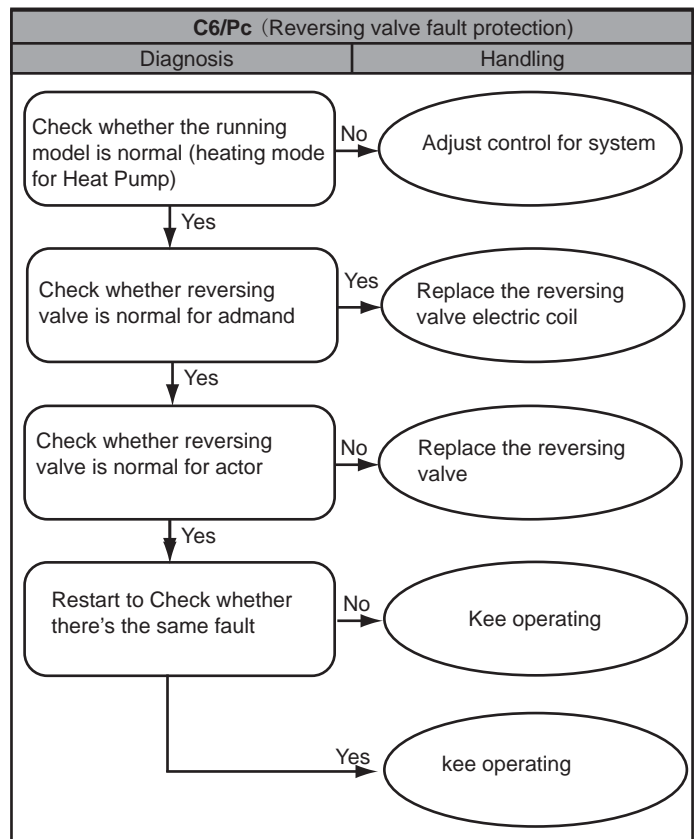
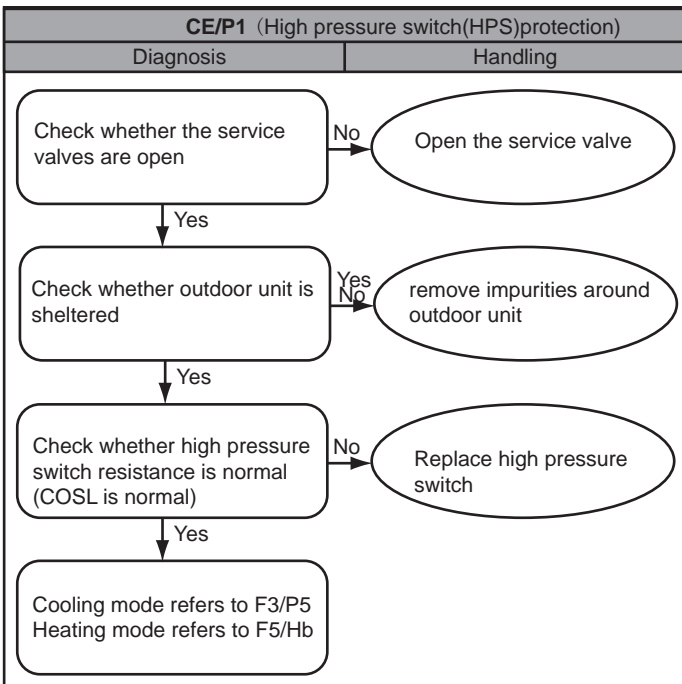
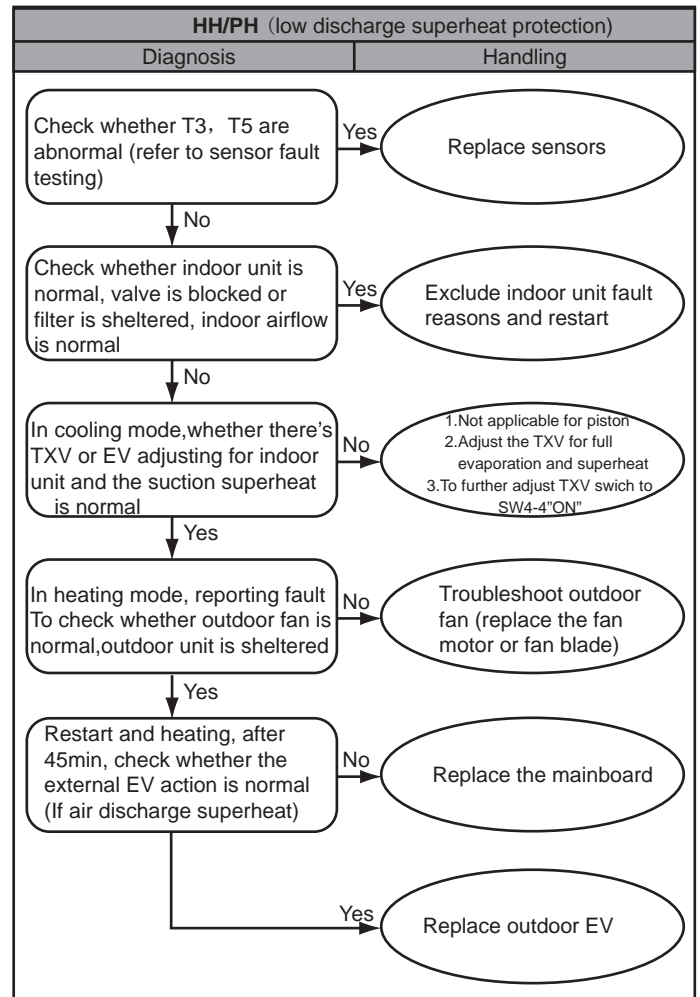
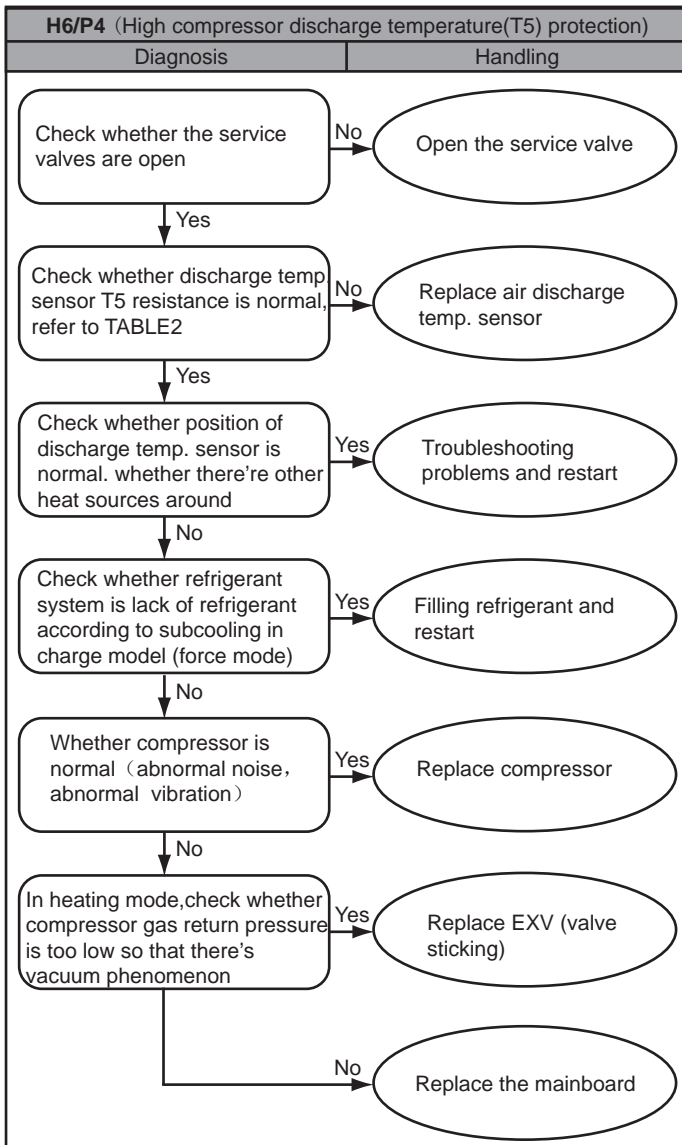

TABLE A

TEMP F	TEMP C	RESISTANCE kΩ	VOLTS DC	TEMP F	TEMP C	RESISTANCE kΩ	VOLTS DC
-5	-20.6	107.732	4.65	90	32.2	7.225	2.36
0	-17.8	93.535	4.6	95	35	6.401	2.21
5	-15	79.521	4.54	100	37.8	5.683	2.07
10	-12.2	67.795	4.47	105	40.6	5.057	1.93
15	-9.4	57.948	4.39	110	43.3	4.509	1.79
20	-6.7	49.652	4.3	115	46.1	4.028	1.67
25	-3.9	42.645	4.21	120	48.9	3.606	1.55
30	-1.1	36.710	4.1	125	51.7	3.233	1.43
40	4.4	27.386	3.86	130	54.4	2.902	1.32
45	7.2	23.732	3.73	135	57.2	2.610	1.22
50	10	20.610	3.59	140	60	2.350	1.13
55	12.8	17.939	3.45	145	62.8	2.119	1.04
60	15.6	15.648	3.3	150	65.6	1.914	0.96
65	18.3	13.681	3.15	155	68.3	1.731	0.88
70	21.1	11.987	2.99	160	71.1	1.574	0.82
75	23.9	10.527	2.83	165	73.9	1.416	0.75
80	26.7	9.265	2.67	170	76.7	1.276	0.68
85	29.4	8.172	2.52				

TABLE B

TEMP F	TEMP C	RESISTANCE kΩ	VOLTS DC	TEMP F	TEMP C	RESISTANCE kΩ	VOLTS DC
-5	-20.6	600.134	4.93	140	60	13.643	3.14
0	-17.8	505.551	4.92	145	62.8	12.359	3.03
5	-15	427.463	4.91	150	65.6	11.214	2.91
10	-12.2	362.739	4.89	155	68.3	10.227	2.8
15	-9.4	308.891	4.87	160	71.1	9.308	2.68
20	-6.7	265.398	4.85	165	73.9	8.485	2.56
25	-3.9	227.481	4.83	170	76.7	7.746	2.45
30	-1.1	195.601	4.8	175	79.4	7.105	2.34
35	1.7	168.707	4.77	180	82.2	6.504	2.23
40	4.4	146.695	4.74	185	85	5.963	2.13
45	7.2	127.258	4.7	190	87.8	5.474	2.02
50	10	110.707	4.66	195	90.6	5.032	1.92
55	12.8	96.572	4.61	200	93.3	4.645	1.83
60	15.6	84.465	4.56	205	96.1	4.28	1.73
65	18.3	74.411	4.51	210	98.9	3.949	1.64
70	21.1	65.408	4.45	215	101.7	3.648	1.56
75	23.9	57.634	4.39	220	104.4	3.383	1.48
80	26.7	50.904	4.32	225	107.2	3.133	1.4
85	29.4	45.258	4.24	230	110	2.904	1.32
90	32.2	40.152	4.16	235	112.8	2.694	1.25
95	35	35.699	4.08	240	115.6	2.503	1.18
100	37.8	31.807	3.99	245	118.3	2.334	1.12
105	40.6	28.398	3.89	250	121.1	2.172	1.06
110	43.3	25.506	3.8	255	123.9	2.024	1
115	46.1	22.861	3.7	260	126.7	1.888	0.95
120	48.9	20.529	3.59	265	129.4	1.767	0.9
125	51.7	18.47	3.48	270	132.2	1.651	0.85
130	54.4	16.708	3.37	275	135	1.544	0.8
135	57.2	15.085	3.26	280	137.8	1.446	0.76

TABLE C1 (For AC model)

NSK-BD020I			V=2*MPa+0.5		
No.	V	Te	Pe	No.	V
		°C	MPa		
1	1.04	-22	0.27	47	2
2	1.07	-21	0.28	48	2.02
3	1.1	-20	0.3	49	2.05
4	1.11	-19.5	0.31	50	2.08
5	1.13	-19	0.31	51	2.11
6	1.14	-18.5	0.32	52	2.14
7	1.16	-18	0.33	53	2.16
8	1.17	-17.5	0.34	54	2.19
9	1.19	-17	0.35	55	2.22
10	1.21	-16.5	0.35	56	2.25
11	1.22	-16	0.36	57	2.28
12	1.24	-15.5	0.37	58	2.31
13	1.26	-15	0.38	59	2.34
14	1.27	-14.5	0.39	60	2.37
15	1.29	-14	0.4	61	2.4
16	1.31	-13.5	0.41	62	2.44
17	1.33	-13	0.41	63	2.47
18	1.35	-12.5	0.42	64	2.5
19	1.37	-12	0.43	65	2.53
20	1.38	-11.5	0.44	66	2.56
21	1.4	-11	0.45	67	2.6
22	1.42	-10.5	0.46	68	2.63
23	1.44	-10	0.47	69	2.67
24	1.46	-9.5	0.48	70	2.7
25	1.48	-9	0.49	71	2.74
26	1.5	-8.5	0.5	72	2.77
27	1.52	-8	0.51	73	2.81
28	1.54	-7.5	0.52	74	2.84
29	1.57	-7	0.53	75	2.88
30	1.59	-6.5	0.54	76	2.92
31	1.61	-6	0.55	77	2.95
32	1.63	-5.5	0.57	78	2.99
33	1.65	-5	0.58	79	3.03
34	1.68	-4.5	0.59	80	3.07
35	1.7	-4	0.6	81	3.1
36	1.72	-3.5	0.61	82	3.14
37	1.75	-3	0.62	83	3.18
38	1.77	-2.5	0.64	84	3.22
39	1.79	-2	0.65	85	3.26
40	1.82	-1.5	0.66	86	3.3
41	1.84	-1	0.67	87	3.35
42	1.87	-0.5	0.68	88	3.39
43	1.89	0	0.7	89	3.43
44	1.92	0.5	0.71	90	3.47
45	1.94	1	0.72	91	3.51
46	1.97	1.5	0.74	92	3.56
17	80.2376	74	8.4881	132	1.4937
18	76.6616	75	8.166	133	1.4551
19	73.2636	76	7.8945	134	1.4177
20	70.0337	77	7.6334	135	1.3813
21	66.9628	78	7.382	136	1.3461
22	64.0424	79	7.1401	137	1.3118
23	61.2643	80	6.9072	138	1.2786
24	58.6208	81	6.683	139	1.2463
25	56.1048	82	6.467	140	1.215
26	53.7095	83	6.259		

TABLE C2 (For HP model)

NSK-BD035I				$V=(8/7)*MPa+0.5$							
No.	V	Te/Tc	Pe/Pc	No.	V	Te/Tc	Pe/Pc	No.	V	Te/Tc	Pe/Pc
		°C	MPa			°C	MPa			°C	MPa
1	0.69	-30	0.17	56	1.37	2.5	0.76	111	2.54	30	1.78
2	0.7	-29	0.18	57	1.39	3	0.78	112	2.56	30.5	1.81
3	0.72	-28	0.19	58	1.4	3.5	0.79	113	2.59	31	1.83
4	0.73	-27	0.2	59	1.42	4	0.8	114	2.62	31.5	1.86
5	0.75	-26	0.22	60	1.43	4.5	0.82	115	2.65	32	1.88
6	0.76	-25	0.23	61	1.45	5	0.83	116	2.68	32.5	1.91
7	0.78	-24	0.24	62	1.47	5.5	0.85	117	2.71	33	1.93
8	0.79	-23	0.25	63	1.48	6	0.86	118	2.74	33.5	1.96
9	0.81	-22	0.27	64	1.5	6.5	0.88	119	2.77	34	1.98
10	0.82	-21	0.28	65	1.52	7	0.89	120	2.8	34.5	2.01
11	0.84	-20	0.3	66	1.53	7.5	0.91	121	2.83	35	2.04
12	0.85	-19.5	0.31	67	1.55	8	0.92	122	2.86	35.5	2.06
13	0.86	-19	0.31	68	1.57	8.5	0.94	123	2.89	36	2.09
14	0.87	-18.5	0.32	69	1.59	9	0.95	124	2.92	36.5	2.12
15	0.88	-18	0.33	70	1.61	9.5	0.97	125	2.95	37	2.15
16	0.89	-17.5	0.34	71	1.62	10	0.98	126	2.98	37.5	2.17
17	0.89	-17	0.35	72	1.64	10.5	1	127	3.02	38	2.2
18	0.9	-16.5	0.35	73	1.66	11	1.02	128	3.05	38.5	2.23
19	0.91	-16	0.36	74	1.68	11.5	1.03	129	3.08	39	2.26
20	0.92	-15.5	0.37	75	1.7	12	1.05	130	3.12	39.5	2.29
21	0.93	-15	0.38	76	1.72	12.5	1.07	131	3.15	40	2.32
22	0.94	-14.5	0.39	77	1.74	13	1.08	132	3.18	40.5	2.35
23	0.95	-14	0.4	78	1.76	13.5	1.1	133	3.22	41	2.38
24	0.96	-13.5	0.41	79	1.78	14	1.12	134	3.25	41.5	2.41
25	0.97	-13	0.41	80	1.8	14.5	1.14	135	3.29	42	2.44
26	0.98	-12.5	0.42	81	1.82	15	1.15	136	3.32	42.5	2.47
27	0.99	-12	0.43	82	1.84	15.5	1.17	137	3.36	43	2.5
28	1.01	-11.5	0.44	83	1.86	16	1.19	138	3.39	43.5	2.53
29	1.02	-11	0.45	84	1.88	16.5	1.21	139	3.43	44	2.56
30	1.03	-10.5	0.46	85	1.9	17	1.23	140	3.46	44.5	2.59
31	1.04	-10	0.47	86	1.92	17.5	1.24	141	3.5	45	2.62
32	1.05	-9.5	0.48	87	1.94	18	1.26	142	3.54	45.5	2.66
33	1.06	-9	0.49	88	1.97	18.5	1.28	143	3.57	46	2.69
34	1.07	-8.5	0.5	89	1.99	19	1.3	144	3.61	46.5	2.72
35	1.09	-8	0.51	90	2.01	19.5	1.32	145	3.65	47	2.76
36	1.1	-7.5	0.52	91	2.03	20	1.34	146	3.69	47.5	2.79
37	1.11	-7	0.53	92	2.06	20.5	1.36	147	3.73	48	2.82
38	1.12	-6.5	0.54	93	2.08	21	1.38	148	3.77	48.5	2.86
39	1.13	-6	0.55	94	2.1	21.5	1.4	149	3.8	49	2.89
40	1.15	-5.5	0.57	95	2.13	22	1.42	150	3.84	49.5	2.93
41	1.16	-5	0.58	96	2.15	22.5	1.44	151	3.88	50	2.96
42	1.17	-4.5	0.59	97	2.17	23	1.46	152	3.93	50.5	3
43	1.19	-4	0.6	98	2.2	23.5	1.49	153	3.97	51	3.03
44	1.2	-3.5	0.61	99	2.22	24	1.51	154	4.01	51.5	3.07
45	1.21	-3	0.62	100	2.25	24.5	1.53	155	4.05	52	3.1
46	1.23	-2.5	0.64	101	2.27	25	1.55	156	4.09	52.5	3.14
47	1.24	-2	0.65	102	2.3	25.5	1.57	157	4.13	53	3.18
48	1.25	-1.5	0.66	103	2.32	26	1.6	158	4.18	53.5	3.22
49	1.27	-1	0.67	104	2.35	26.5	1.62	159	4.22	54	3.25
50	1.28	-0.5	0.68	105	2.38	27	1.64	160	4.26	54.5	3.29
51	1.3	0	0.7	106	2.4	27.5	1.66	161	4.31	55	3.33
52	1.31	0.5	0.71	107	2.43	28	1.69	162	4.35	55.5	3.37
53	1.33	1	0.72	108	2.45	28.5	1.71	163	4.39	56	3.41
54	1.34	1.5	0.74	109	2.48	29	1.73	164	4.44	56.5	3.45
55	1.36	2	0.75	110	2.51	29.5	1.76	165	4.48	57	3.49



