

Features _ icon

 Supreme Energy Efficiency	 Two Thermistor Control
 High Operation Reliability	 Auto Changeover
 Forced Cooling Operation	 Long & High Elevation Piping
 Night Silent Operation	 Zone Control
 Weekly Program	 Wireless Remote Controller
 Turbo Fan	 Jet Cool
 High Head Drain Pump	 24-Hour ON/OFF Setting Timer
 Low Standby Power	 Soft Dry Operation Mode
 Auto Restart	 Monitoring PCB
 Central Controller	 Wiring Error Check
 Group Control	 Peak Current Control
 Child Lock	 Mode Lock



LG Electronics AE Company, System Air Conditioning

P.O. Box 0819-06572, Panamá, Rep. de Panamá
Tel: (507) 210-6000 Fax: (507) 210-3402

www.lgeaircon.com

Copyright © 2013 LG Electronics. All rights reserved.
Printed in Panamá, 2013-05



INVERTER SPLIT MULTI / SINGLE 2013



Brand Power

LG's consistent efforts in innovation have made LG Air Conditioning and Energy Solution a true global leader in HVAC businesses.

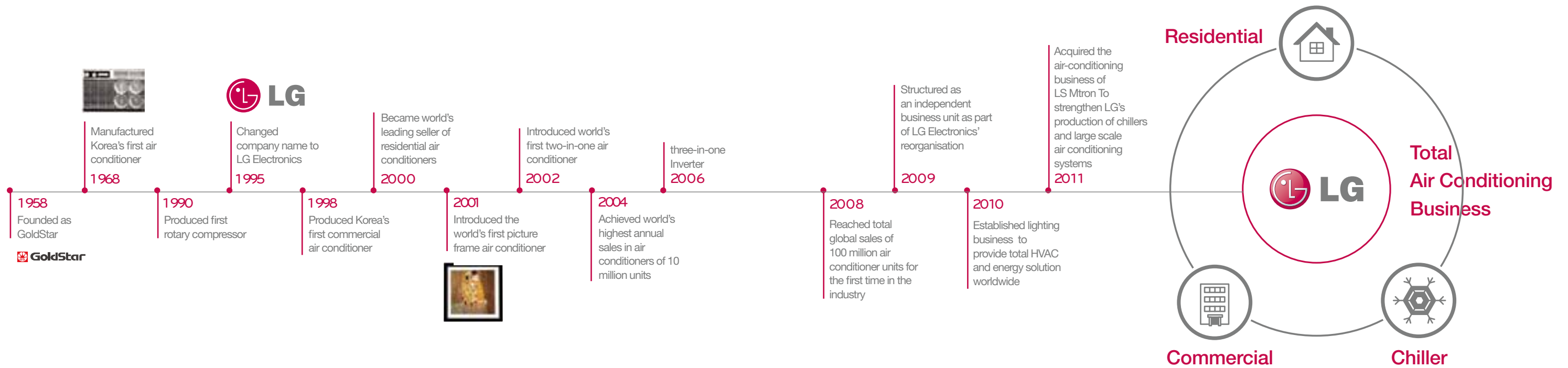

Launched in 2009, LG Electronics Air Conditioning & Energy Solution Company (LG AE) provides total solutions in heating, ventilation and air conditioning (HVAC). LG AE's offerings include residential and commercial air conditioners, lighting, home and building management systems.

LG AE was formed as part of the company's strategic plan to expand its business horizons into the B2B sector, reinforcing its presence in the commercial products and solutions business. In 2010, along with aggressive reinforcement of its position in commercial air conditioning, LG established lighting businesses to further increase its focus on B2B and on energy efficient business solutions. Based on its

great success in the consumer market, the new Air Conditioning and Energy Solution Company allows LG to be more competitive in the commercial heating, ventilation, air conditioning (HVAC) and energy businesses worldwide. LG expects its strength in air conditioners to become a strong driver of growth for the entire company as the industry expands.

Through its relentless efforts in innovation and development, LG AE is continuing to consolidate its leadership as a global HVAC and energy solution company, with a central focus on eco-friendliness and energy efficiency.



Quality Control

Development

- Performance Test (Cool/Heat)
- EER Test
- Abnormal Noise Test
- Reliability Test
- Safety Test
- Air current Distribution Test
- Temp./Humidity Performance Test
- Difference of altitude Test
- E.M.I (Electromagnetic Interference)
- E.M.S (Electromagnetic Susceptibility)
- E.M.C (Electromagnetic Compatibility)



Mass Production



IQC

- Part Life Test (PLT)
- 6sigma Distribution Control
- Vendor Quality Improvement
- Consulting



LQC

- Basic Performance Inspection
- Safety Inspection
- Movement/Structure/
- Appearance Inspection



OQC

- Structure / Appearance inspection
- Early Life Test (ELT)
- Smog Test (Refrigerant leakage)

PL (Product Liability)

Safety Evaluation

- Product Safety Check
- PL Consulting List

Test Product Safety

- Fire Test
- Fire Chamber

Assure Part Safety

- Evaluation Safety
- PartVendor Audit

Standard Management



ISO 9001

- Certificate Quality Management System LG Electronics (Global Standard)
- Certificate Authority : UL Korea



KS

- Certificate A/C Production System of LG Electronics (Korea Standard)
- Certificate Authority : Korea Standard Association



KOLAS

- LG Electronics Revision System : State Organ (International Authorization)
- Certificate Authority : The Ministry of Commerce
- Measuring Instruments in Factory: Self Revision



UL TCP

- UL recognize LG Product through a test result (In LG)
- Certificate Authority : UL

Quality Assurance Lab

Testing labs are equipped with certified equipment and facilities to ensure product reliability and leading technology



Noise Testing Chamber



Environmental Testing Chamber



Long Piping and Elevation Testing

LG Energy Lab

The LG Energy Lab is located in the town of Wargnies-Le-Petit, near Valenciennes, Northern France. It is used to field-test upcoming Residential and Commercial Air Conditioning and Heating products. The aim of the Energy Lab is to guarantee the reliability of new air conditioning and heating products in all seasons, even in extreme weather conditions, before they are commercially available.





MULTI SPLIT

- 10 Outdoor Units
- 26 Indoor Units
- 36 Accessories



LG can improve your quality of life

in an affordable, eco-friendly way. Over the years, LG has strived to meet the demand for high quality air conditioning solutions with greater energy efficiency, which can reduce energy costs and also help to protect the environment. Greater energy savings can be achieved over the lifetime of the product which can offer cost savings to your home and business.

Furthermore, LG's air conditioners are reliable products with long lifespans designed to provide years of hassle-free performance.



MULTI SPLIT

10 OUTDOOR UNITS

26 INDOOR UNITS







36 ACCESSORIES

MULTI SPLIT

2013 LINE-UP

Wide Range

LG MULTI systems offer various indoor units and outdoor units up to 14.1kW. More than available with the 6 types of outdoor unit and 20 types of indoor unit

Type kBtu/kW	Multi Piping Type	Max. Indoor units	Phase	Combination Sample
17.1 / 5.03	A2UQ18GFA0 	2	1ø	
26 / 7.6	A3UQ26GFA0 	3	1ø	
30 / 8.8	A4UQ30GFA0 	4	1ø	
36 / 10.6	A5UQ36GFA0 	5	1ø	
48 / 14.1	A5UQ48GFA0 	5	1ø	
Type kBtu/kW	DB Box Type	Max. Indoor units	Phase	Combination Sample
40 / 11.7	A7UQ40GFA0 	7	1ø	
48 / 14.1	A8UQ48GFA0 	8	1ø	
54 / 15.9	A8UQ54GFA0 	8	1ø	

Combination ratio is 100% full load operation and 130% in case of load diversity

Combination with a variety of Indoor Units

Type kBtu/kW	Wall Mounted	Ceiling Concealed Ducts		
		Ceiling Cassettes 4 Way	Low Static	High Static
9 / 2.6	ART COOL  AMNC09GDBR0 Health+  AMNC09GDBA2  AMNC09GDBW0 <small>* Indicates panel color_Mirror(R), White(W)</small>			
	ART COOL  AMNC09GDBR0 Health+  AMNC09GDBA2  AMNC09GDBW0 <small>* Indicates panel color_Mirror(R), White(W)</small>	 AMNC12GTRA2	 AMNC12GB1A2	
18 / 5.3	ART COOL  AMNC09GDBR0 Health+  AMNC09GDBA2  AMNC09GDBW0 <small>* Indicates panel color_Mirror(R), White(W)</small>	 AMNC18GTQA2	 AMNC18GB2A2	 AMNC18GBHA2
	ART COOL  AMNC09GDBR0 Health+  AMNC09GDBA2  AMNC09GDBW0 <small>* Indicates panel color_Mirror(R), White(W)</small>	 AMNC24GTPA2	 AMNC24GB2A2	 AMNC24GBHA2

Supreme Energy Efficiency



The revolutionary inverter technology boasts a powerful yet quite performance while minimising energy consumption.

High efficiency
COP 4.0 Weighted COP 5.0



* Based on A4UQ38GFA0

- 1 Powerful BLDC Compressor
- 2 BLDC Fan Motor Technology
- 3 Highly Efficient Heat Exchanger

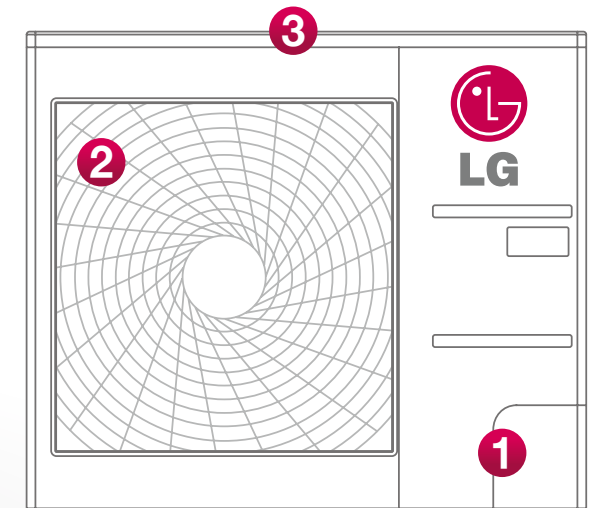

Powerful BLDC Compressor

LG air conditioners are equipped with a BLDC compressor that uses a strong neodymium magnet. The compressor has improved efficiency compared to standard AC inverter products and it is optimised for partial load operation.

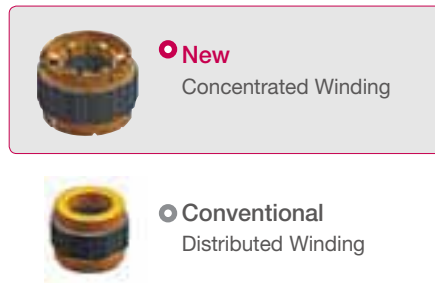
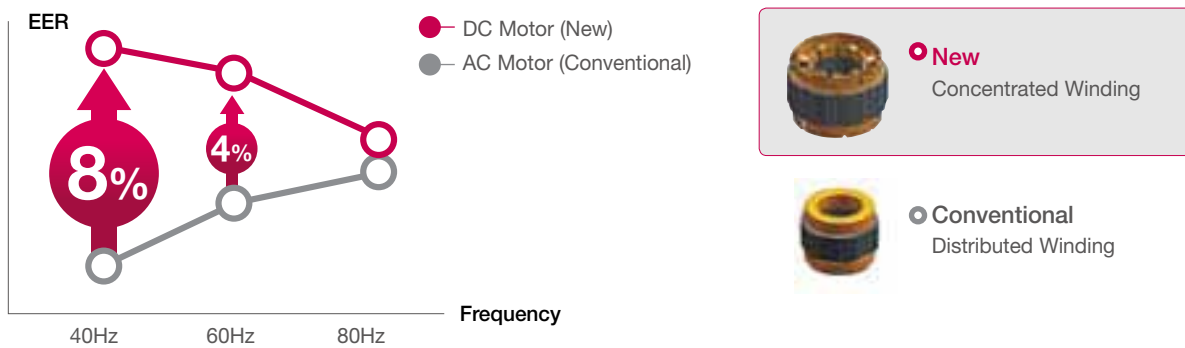

BLDC Fan Motor Technology

The LG BLDC fan motor offers additional energy savings of up to 40% at low speeds and 20% at high speeds compared to an AC motor.



BLDC Fan Motor

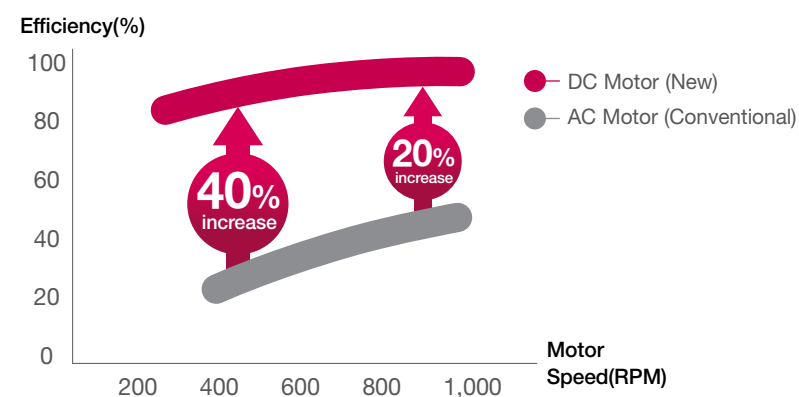

Heat Exchanger Improvement

Wide Louver fin

Improved heat exchanger efficiency of up to 28%, using MULTI V (LG VRF) technology.

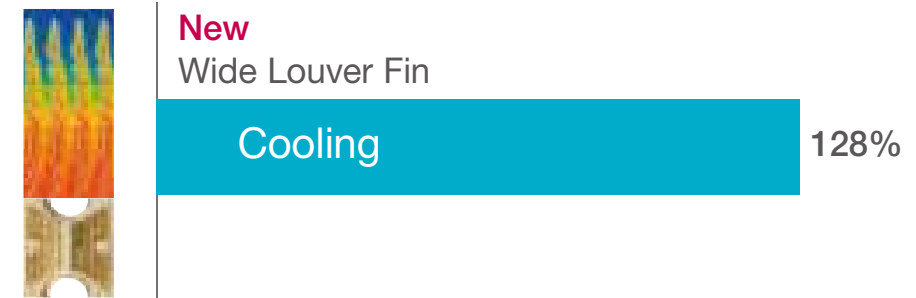

Heat Exchange Rate(%)

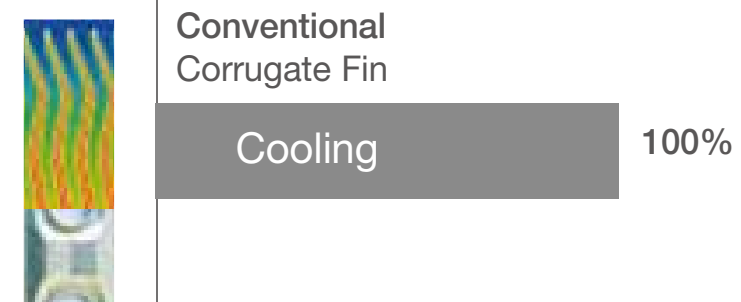

Heat Exchange Rate(%)

High Operation Reliability



36% Faster



Quick Operation Response up to 36% faster
Wide Operation Range -10~48°C

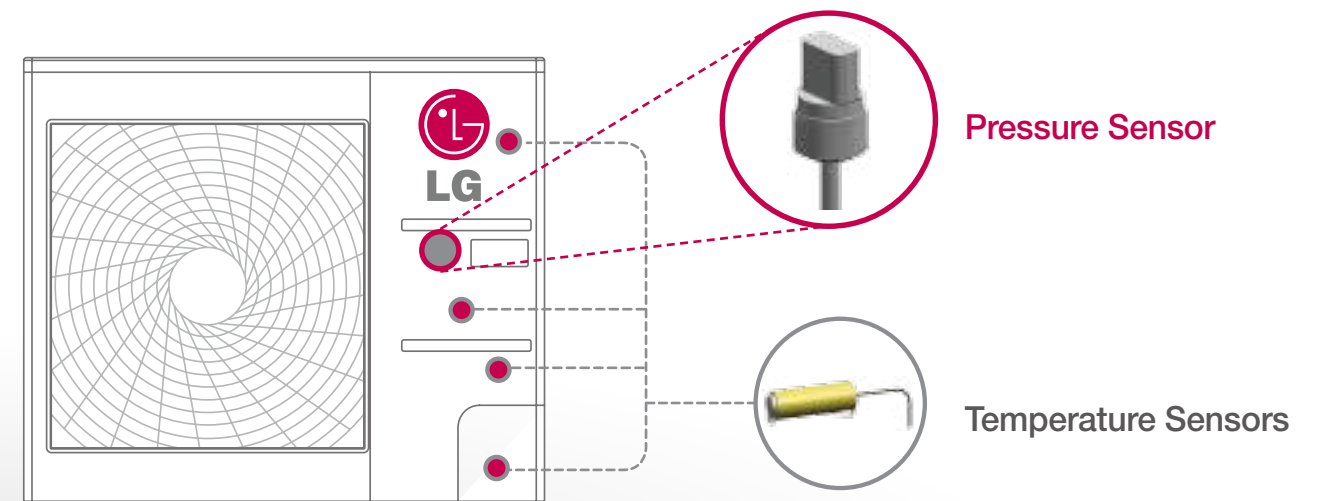

High Reliability with Pressure Control

Improve reliability using pressure and temperature sensors.

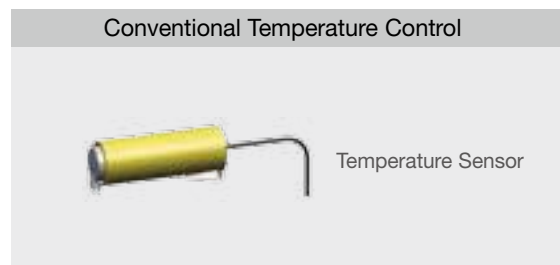

Calculates target pressure according to indoor/outdoor temperature, desired temperature and piping length.

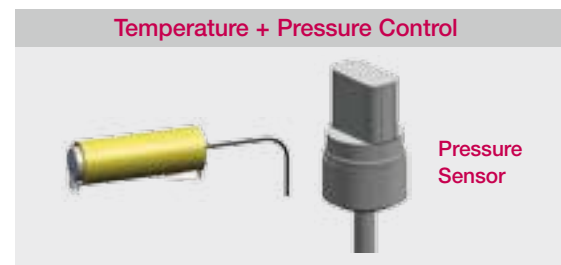

Senses and controls pressure directly using pressure sensor for faster and more exact response to load variation

Quick Cooling Response

Pressure control takes up to 36% less time to reach the desired temperature with a high level of accuracy and stability.

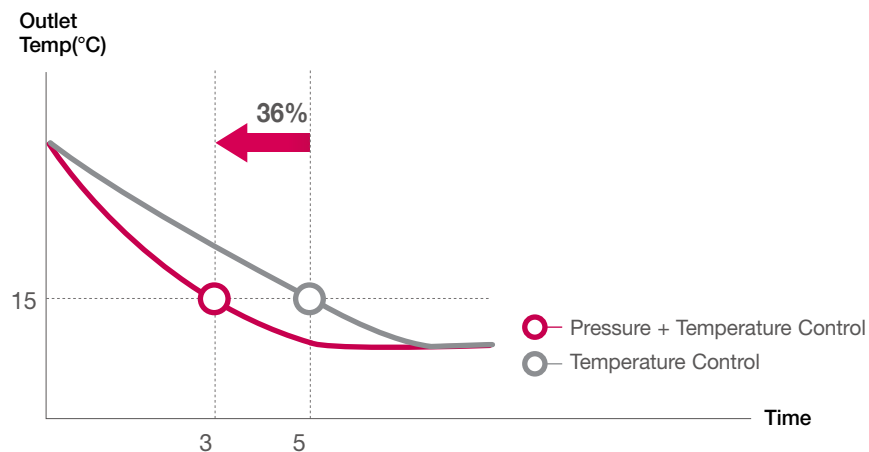

36% Quicker

The indoor environment can be made more comfortable, faster and more accurately.

*Based on internal test data

Wide Operation Range

Wide operating range with high/low pressure control.

• **Wide Operation Range : Cooling -10°C ~ 48°C**

Indoor Temp.(°C)

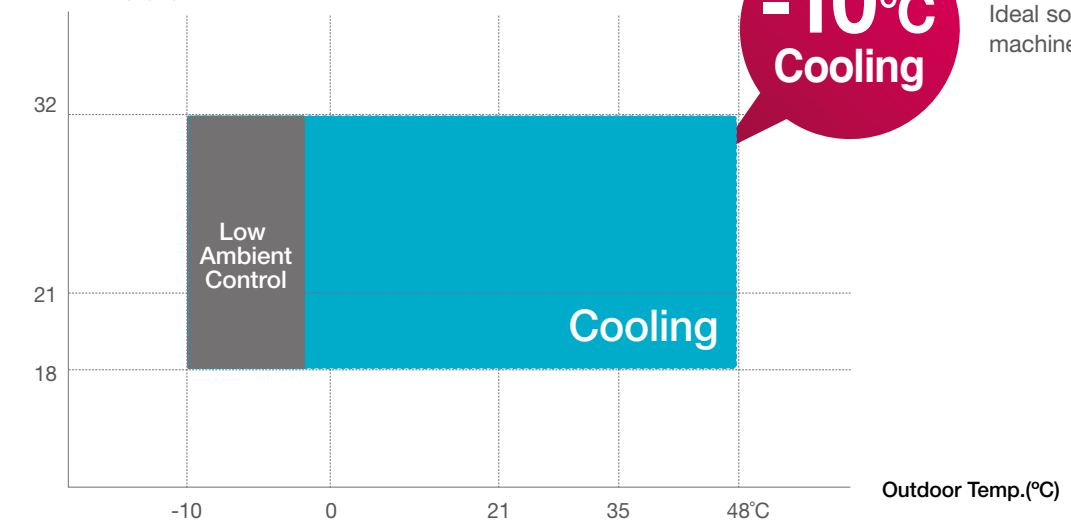

Stable Performance

Stable performance regardless of outdoor temperature.



Save Cost & Energy

Peak Current Control

Peak current control function maintains the current air conditioning setting, keeping its performance under the maximum level, to save costs and energy.

Energy costs can be reduced when using this mode in conjunction with energy tariffs that charge higher prices at peak periods.

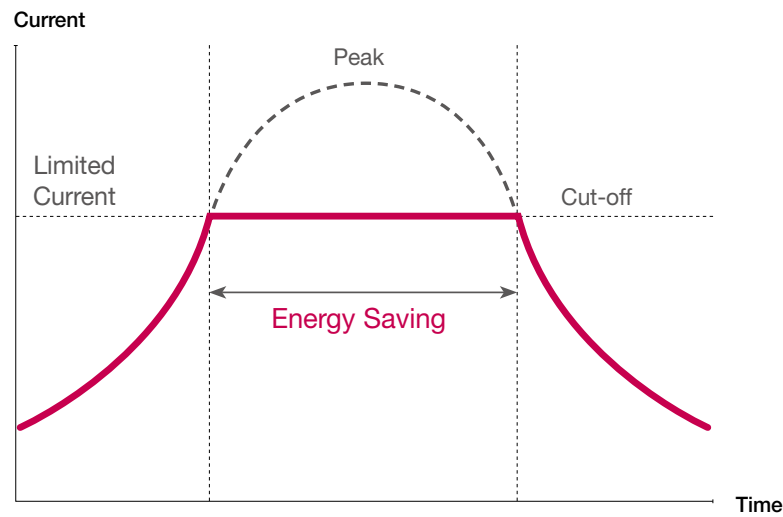

- Full load consumption : 2.5 kW
- Max power consumption : 2.4 kW **5% Save!**
- Max power consumption : 1.9 kW **25% Save!**

* 26 kBTu/h model for example

Standby Mode

This function can minimise power consumption by turning power off on the PCB except for the MICOM which receives signals.

Standby power

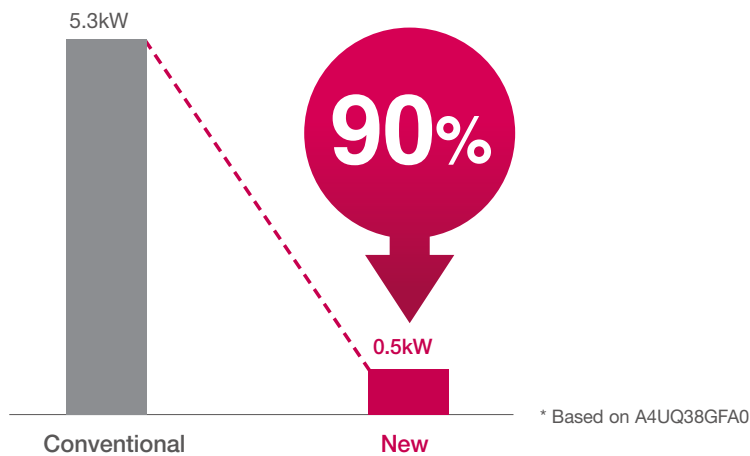

* Based on A4UQ38GFA0

Quiet Operation

Night Silent Operation

Night silent operation can reduce noise levels at night time by simply setting the dip switch on the PCB of the outdoor unit.

• Cooling mode

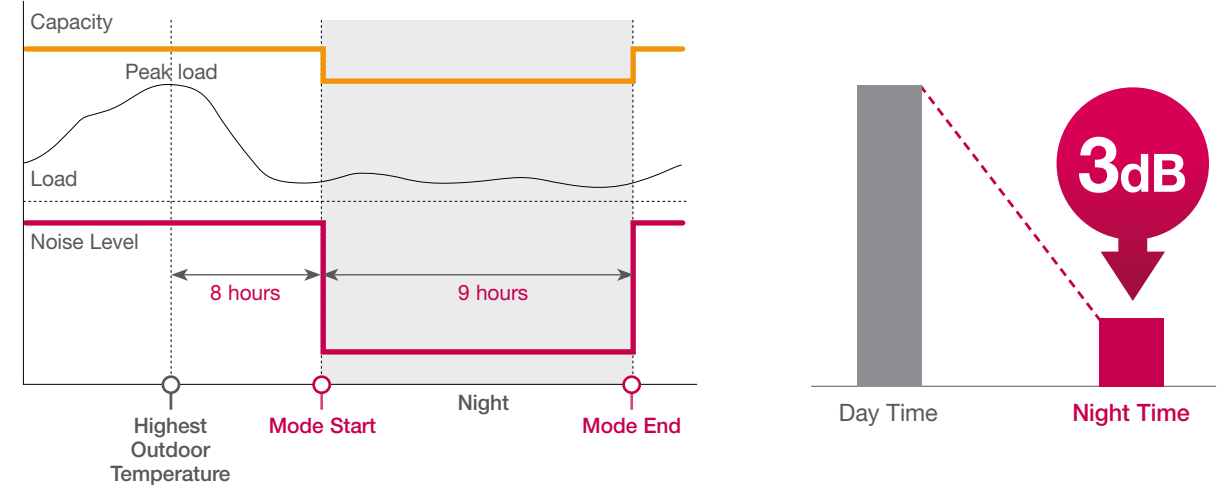

Improved Fan and Grille

The **New Grille** shape design on the outdoor unit helps to disperse air more efficiently which improves heat exchange and reduces noise level.

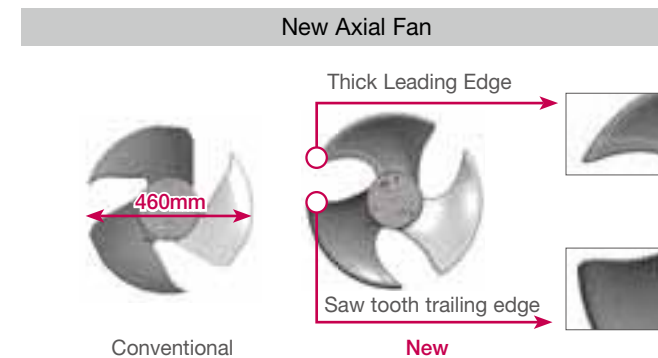
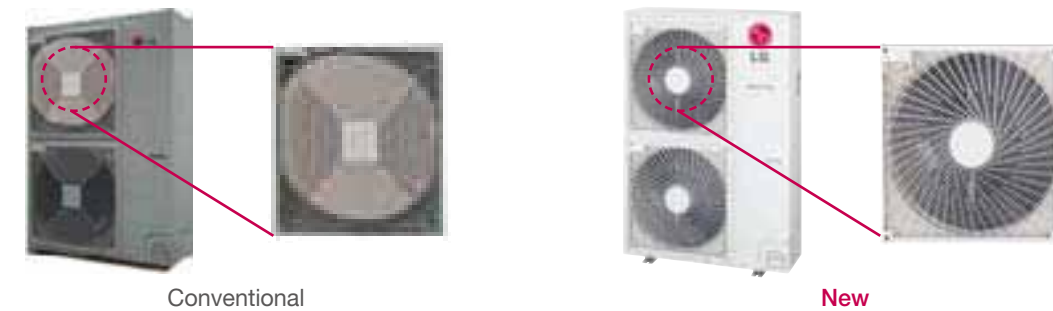

The **New Axial Fan** has a thick front edge and smooth rear edge, this provides a high efficiency, low noise, wide fan, as well as improving the air flow rate.

Easy Installation & Maintenance

Compact Size & Lightweight

The new MULTI F are more compact and lighter compared to previous models. The reduction in weight makes it easier to carry and install.

Weight Refrigerant



Inner Support

The new model has a better design so that the piping cover is enclosed and the size reduced by 80mm and 25mm at the side and back respectively. As a result it is now possible to install the unit close to a wall. As well as the easily accessible service valve, it is possible to conveniently service the outdoor unit when installed below a window.

Support enclosed inside

Main service valve raised / easy manipulation



Wiring Error Check

Installers can check whether the transmission cable has been connected correctly by using the wiring error check function. Previously when the transmission cable was wrongly connected, several checks and reinstallations were needed. However the wiring error check can reduce the time taken to check for transmission cable errors.

• Check with Outdoor PCB : When error → LED is turned on

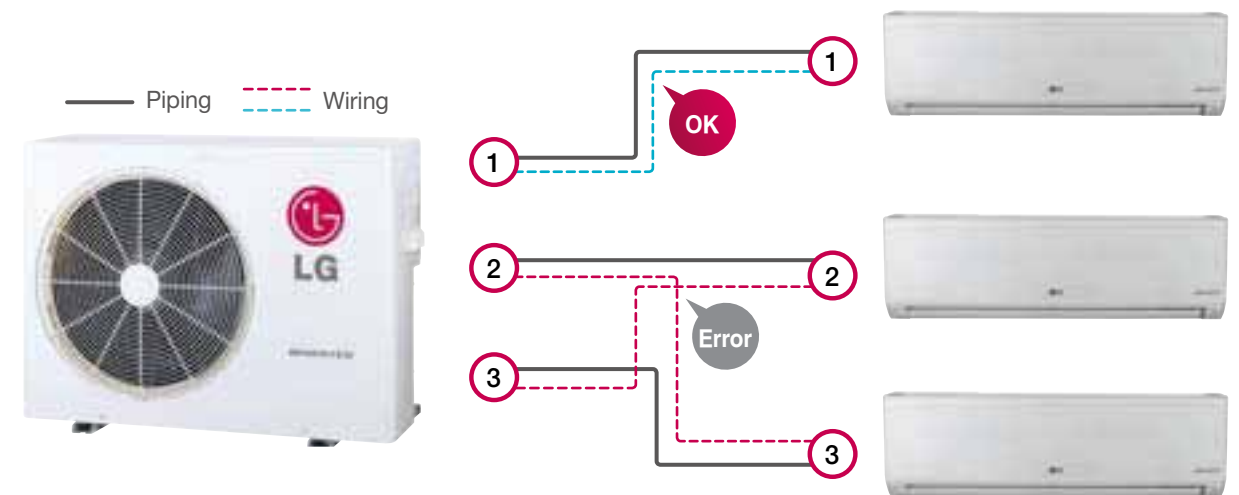

Monitoring PCB

Users can easily access data by opening the control cover and checking the PCB on the side of the unit.

Easy to check PCB

- Top Cover
- PCB Cover

• Control Cover



Easy Installation & Maintenance

Forced Cooling Operation

The forced cooling operation allows refrigerant to be recharged or pumped down, regardless of the indoor temperature. More importantly this function can be used when indoor units are being moved or repaired.

1) Recharging

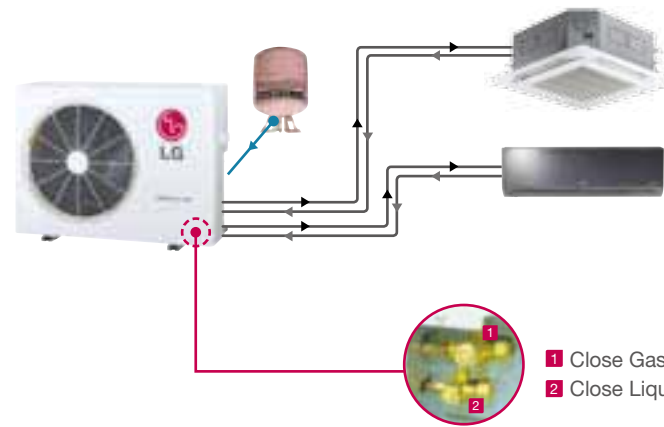

2) Pump Down

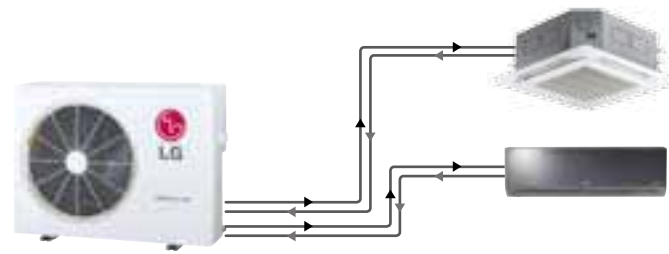

LG MV

LG MV helps engineers to inspect and monitor air conditioning units easily. Information is provided by product type. (Single CAC & MULTI)



- IDU info.
- Cycle & valves
- Actuator info.
- Sensors & Electric
- ODU info.

LG MV provides cycle information with diagrams and the user can check accumulated data on a graph.

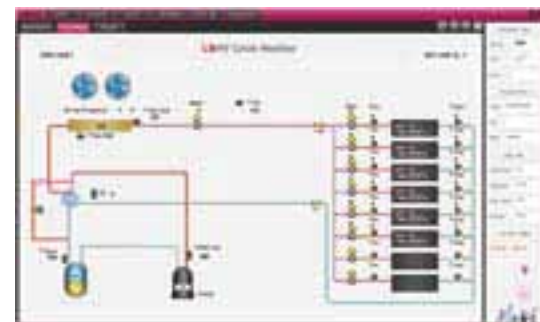

A manager can easily check the error status by looking at the indicator information. (Troubleshooting guide)

Error indicator

Error Code	Contents
01	Indoor Room sensor error
02	IDU pipe in temp. sensor error
03	comm. Problem between IDU and REMOCON

• LGMV for single CAC and multi is different than LGMV for Multi V.

Flexible Combination

Long and High Elevation Piping

FM56AH supports piping lengths of up to 145m and elevations of up to 30m for more flexibility in installations.

*Multiple Piping Type

Piping Length (m)	A2UQ18GFA0	A3UQ26GFA0	A4UQ30GFA0	A5UQ36GFA0	A5UQ48GFA0
Total	30	60	70	75	85
Max / Room	20	25	25	25	25
Allowable Elevation					
(Indoor-Outdoor)	15	15	15	15	15
(Indoor-Indoor)	7.5	7.5	7.5	7.5	7.5

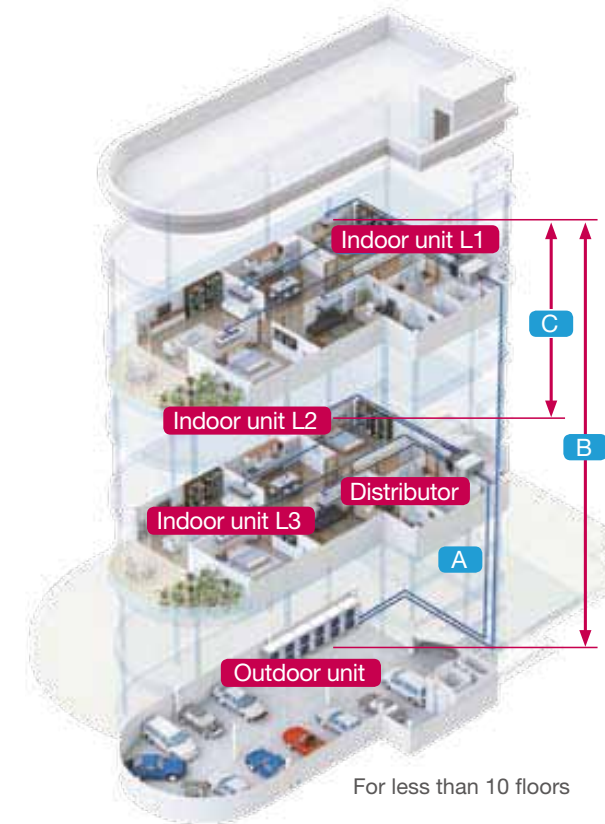

*Distributor Box Type

Piping Length (m)	A7UQ40GFA0	A8UQ48GFA0	A8UQ54GFA0
Total Pipe (A+L1+L2+L3)	135	145	145
Main Pipe (A)	55	55	55
Total Branch Pipe (L1+L2+L3)	80	90	90
Each Branch Pipe	15	15	15
Allowable Elevation			
Indoor-Outdoor (B)	30	30	30
Indoor-Indoor (C)	15	15	15

A2UQ18GFA0 / A3UQ26GFA0



Outdoor Unit				A2UQ18GFA0	A3UQ26GFA0
Capacity	Cooling	Min.-Rated-Max.	kW	1.45 ~ 5.01 ~ 6.16	1.45 ~ 7.62 ~ 8.67
		Min.-Rated-Max.	Btu/h	4,950 ~ 17,100 ~ 21,000	4,950 ~ 26,000 ~ 29,600
Power Input	Cooling	Min.-Rated-Max.	kW	0.47 ~ 1.38 ~ 1.80	0.47 ~ 2.06 ~ 2.43
COP			W/W		
Energy Label	Cooling		-		
Power Supply			V , Ø , Hz	220-240 / 1 / 50/ 60	220-240 / 1 / 50/ 60
Running Current	Cooling	Min.-Rated-Max.	A	2.1 ~ 6.6 ~ 9.0	2.1 ~ 9.4 ~ 11.0
		Sum of Indoor Units Capacity	kBtu/h	30	54
Combination		Number of Indoor Units	EA	2	3
		Dimensions	W x H x D	mm	770 x 545 x 288
Net Weight			kg (lbs)	36(79.4)	45(99.2)
Refrigerant	Type		-	R410A	R410A
Sound Pressure Level	Cooling	Rated	dB(A)	48	48
Piping Connections	Liquid	Outer Dia.	mm(inch) x No.	Ø 6.35 (1/4) x 2	Ø 6.35 (1/4) x 3
	Gas	Outer Dia.	mm(inch) x No.	Ø 9.52 (3/8) x 2	Ø 9.52 (3/8) x 3
Piping Length	Total Piping	Max.	m (ft)	30 (98.4)	60 (196.8)
	Each Branch Piping	Max.	m (ft)	20 (65.6)	25 (82.0)
Maximum	Outdoor Unit ~ Indoor Unit	Max.	m (ft)	15 (49.2)	15 (49.2)
Height Difference	Indoor Unit ~ Indoor Unit	Max.	m (ft)	7.5 (24.6)	7.5 (24.6)
Operation Range (Outdoor Temperature)	Cooling	Min. ~ Max.	°C DB (°F DB)	-5(23.0) ~ 48 (118.4)	-5(23.0) ~ 48 (118.4)

Notes :

- All data are based on the following conditions:
 - Cooling Temperature : Indoor 27°C(80.6°F) DB / 19°C(66.2°F) WB
 Outdoor 35°C(95°F) DB / 24°C(75.2°F) WB
 - Piping Length : Interconnected Pipe Length = 7.5m
 - Difference Limit of Elevation (Outdoor ~ Indoor Unit) is Zero.
- Wiring cable size must comply with the applicable local and national code.
- Due to our policy of innovation some specifications may be changed without notification.
- Sound Level Values are measured at Anechoic chamber.

A4UQ30GFA0 / A5UQ36GFA0 / A5UQ48GFA0



Outdoor Unit				A4UQ30GFA0	A5UQ36GFA0	A5UQ48GFA0
Capacity	Cooling	Min.-Rated-Max.	kW	2.08 ~ 8.79 ~ 11.4	2.08 ~ 10.84 ~ 13.0	2.24 ~ 14.1 ~ 13.4
		Min.-Rated-Max.	Btu/h	7,100 ~ 30,000 ~ 39,000	7,100 ~ 37,000 ~ 44,000	7,640 ~ 48,000 ~ 55,200
Power Input	Cooling	Min.-Rated-Max.	kW	0.68 ~ 2.25 ~ 3.60	0.68 ~ 2.75 ~ 3.75	0.78 ~ 3.7 ~ 4.98
COP			W/W			
Energy Label	Cooling		-			
Power Supply			V , Ø , Hz	220 - 240 / 1 / 50 / 60	220-240 / 1 / 50/60	220-240 / 1 / 50/60
Running Current	Cooling	Min.-Rated-Max.	A	3.2 ~ 9.8 ~ 16.0	3.2 ~ 12.5 ~ 17.0	3.5 ~ 17.0 ~ 23
		Sum of Indoor Units Capacity	kBtu/h	54	56	68
Combination		Number of Indoor Units	EA	4	5	5
		Dimensions	W x H x D	mm	950 x 834 x 330	950 x 834 x 330
Net Weight			kg (lbs)	64 (141.1)	64 (132.3)	64 (132.3)
Refrigerant	Type		-	R410A	R410A	R410A
Sound Pressure Level	Cooling	Rated	dB(A)	50	51	53
Piping Connections	Liquid	Outer Dia.	mm(inch) x No.	Ø 6.35 (1/4) x 4	Ø 6.35 (1/4) x 5	Ø 6.35 (1/4)
	Gas	Outer Dia.	mm(inch) x No.	Ø 9.52 (3/8) x 4	Ø 9.52 (3/8) x 5	Ø 9.52 (3/8)
Piping Length	Total Piping	Max.	m (ft)	70 (229.7)	75 (246.1)	85 (278.9)
	Each Branch Piping	Max.	m (ft)	25 (82.0)	25 (82.0)	25 (82.0)
Maximum	Outdoor Unit ~ Indoor Unit	Max.	m (ft)	15 (49.2)	15 (49.2)	15 (49.2)
Height Difference	Indoor Unit ~ Indoor Unit	Max.	m (ft)	7.5 (24.6)	7.5 (24.6)	7.5 (24.6)
Operation Range (Outdoor Temperature)	Cooling	Min. ~ Max.	°C DB (°F DB)	-5(23.0) ~ 48 (118.4)	-5(23.0) ~ 48 (118.4)	-10 (14.0) ~ 48 (118.4)

Notes :

- All data are based on the following conditions:
 - Cooling Temperature : Indoor 27°C(80.6°F) DB / 19°C(66.2°F) WB
 Outdoor 35°C(95°F) DB / 24°C(75.2°F) WB
 - Piping Length : Interconnected Pipe Length = 7.5m
 - Difference Limit of Elevation (Outdoor ~ Indoor Unit) is Zero.
- Wiring cable size must comply with the applicable local and national code.
- Due to our policy of innovation some specifications may be changed without notification.
- Sound Level Values are measured at Anechoic chamber.

A7UQ40GFAO / A8UQ48GFAO / A8UQ54GFAO



Outdoor Unit				A7UQ40GFAO	A8UQ48GFAO	A8UQ54GFAO
Capacity	Cooling	Min.-Rated-Max.	kW	2.24 ~ 11.7 ~ 13.5	2.24 ~ 14.1 ~ 16.2	2.24 ~ 15.8 ~ 17.0
		Min.-Rated-Max.	Btu/h	7,640 ~ 40,000 ~ 46,000	7,640 ~ 48,000 ~ 55,200	7,640 ~ 54,000 ~ 58,080
Power Input	Cooling	Min.-Rated-Max.	kW	0.78 ~ 2.60 ~ 4.15	0.78 ~ 3.30 ~ 4.98	0.78 ~ 4.6 ~ 5.1
COP			W/W			
Energy Label	Cooling		-			
Power Supply			V , Ø , Hz	220 - 240 / 1 / 50 / 60	220 - 240 / 1 / 50 / 60	220-240 / 1 / 50/60
Running Current	Cooling	Min.-Rated-Max.	A	3.5 ~ 11.4 ~ 18.4	3.5 ~ 14.5 ~ 18.4	3.5 ~ 19.2 ~ 23
		Sum of Indoor Units Capacity	kBtu/h	63	72	72
Combination		Number of Indoor Units	EA	7	8	8
		Dimensions	W x H x D	mm	950 x 1,170 x 330	950 x 1,170 x 330
Net Weight			kg (lbs)	82 (180.7)	82 (180.7)	82 (180.7)
Refrigerant	Type		-	R410A	R410A	R410A
Sound Pressure Level	Cooling	Rated	dB(A)	52	53	54
Piping Connections	Liquid	Outer Dia.	mm(inch) x No.	Ø 9.52 (3/8)	Ø 9.52 (3/8)	Ø 9.52 (3/8)
	Gas	Outer Dia.	mm(inch) x No.	Ø 15.88 (5/8)	Ø 15.88 (5/8)	Ø 15.88 (5/8)
Piping Length	Total Piping	Max.	m (ft)	135 (442.9)	145 (475.7)	145 (475.7)
	Main Piping	Max.	m (ft)	55 (180.4)	55 (180.4)	55 (180.4)
	Total Branch Piping	Max.	m (ft)	80 (262.5)	90 (295.3)	90 (295.3)
	Each Branch Piping	Max.	m (ft)	15 (49.2)	15 (49.2)	15 (49.2)
Maximum Height Difference	Outdoor Unit ~ Indoor Unit	Max.	m (ft)	30 (98.4)	30 (98.4)	30 (98.4)
	Indoor Unit ~ Indoor Unit	Max.	m (ft)	15 (49.2)	15 (49.2)	15 (49.2)
Operation Range (Outdoor Temperature)	Cooling	Min. ~ Max.	°C DB (°F DB)	-10 (14.0) ~ 48 (118.4)	-10 (14.0) ~ 48 (118.4)	-10 (14.0) ~ 48 (118.4)

Notes :

1. All data are based on the following conditions:

- Cooling Temperature : Indoor 27°C(80.6°F) DB / 19°C(66.2°F) WB
Outdoor 35°C(95°F) DB / 24°C(75.2°F) WB

- Piping Length : Interconnected Pipe Length = 7.5m

- Difference Limit of Elevation (Outdoor ~ Indoor Unit) is Zero.

2. Wiring cable size must comply with the applicable local and national code.

3. Due to our policy of innovation some specifications may be changed without notification.

4. Sound Level Values are measured at Anechoic chamber.

Therefore, these values can be increased owing to ambient conditions during operation.

Indoor Units



Wall Mounted Artcool

Aesthetic Design

You no longer need to be told what your air conditioner should look like. The ARTCOOL series have outstanding designs and have been awarded the International Forum Design Award, the Reddot Design Award and the G Mark.



Tempered Glass

Luster and brightness maintained for extended period of time without tarnishing or fading

Flow Line

Catchy eye level design that flows evenly from the top all the way to the bottom

High Intensity LED

Elegant display with smart white lit trim

Chrome Trim Line

Delicately slim yet powerfully constructed to ensure extended durability

ARTCOOL



Mirror
AMNC09GDBR0 / AMNC12GDBR0
AMNC18GDCR0 / AMNC24GDCR0



White
AMNC09GDBW0 / AMNC12GDBW0
AMNC18GDCW0 / AMNC24GDCW0

Wall Mounted Artcool & Health+

Filtering (Virus & Allergy Safe Filter)

The virus and allergy safe filters are scientifically proven to deactivate viruses that may pose risks to health .



Virus Deactivation

The LG virus & allergy safe filter blocks neuramidase and hemagglutinin, which is activated when the virus breaks up from host cell to proliferate.

Allergy Filter

Allergy care filter coated with allergy decomposition substance

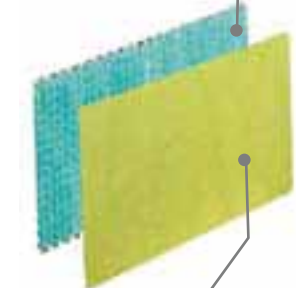

Virus Filter

Sterilising filter with anti-virus coating

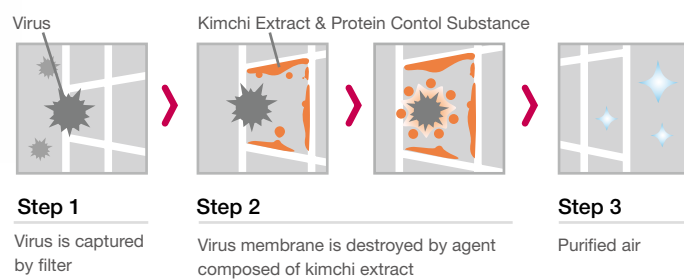
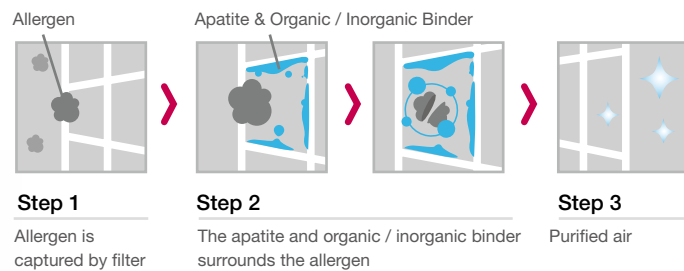

Certified by British Allergy Foundation (2009.01)



Certified by Kitasato Institute



Deodorising (Triple Filter)

The triple filter consists of three special filters that can reduce the side effects caused by some organic compounds including formaldehyde. It has the ability to remove unpleasant odours and can create a more comfortable environment.

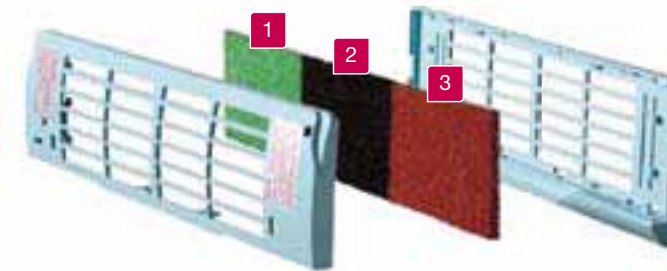

- 1 Red filter removes smells such as smoke and food smells.
- 2 Black filter removes the odour of new buildings such as formaldehyde.
- 3 Blue filter removes the chemical smells such as the smell of fresh paint.

Eliminating (Plasma Filter)

The plasma air purifying system was initially developed by LG not only for reduction of microscopic contaminants and dust, but also for the removal of house mites, small dust particles, and pet fur in order to reduce allergy and asthma symptoms.

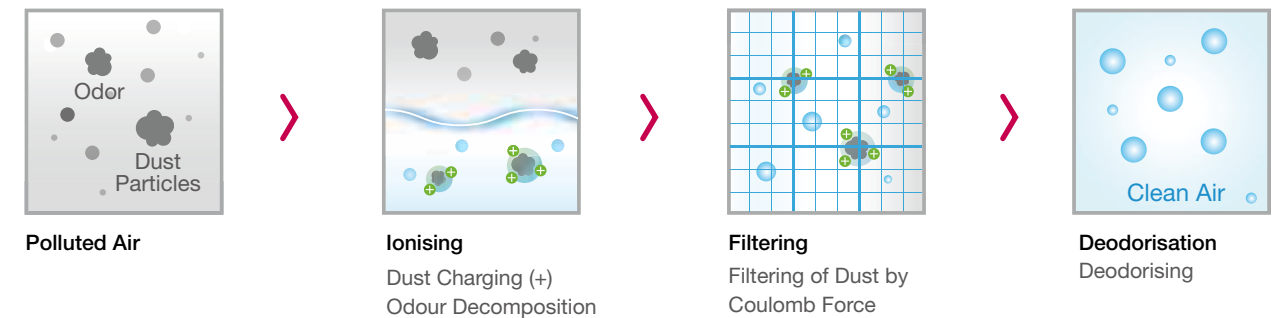

Auto Cleaning

A major cause of air conditioner odours is mould and bacteria that can breed in the heat exchanger. The auto clean function dries the wet heat exchanger to prevent mould and bacteria from breeding which can significantly reduce smells and saves the user from frequent cleaning.

Conventional

The main causes of odour within air conditioners is mould and bacteria in the heat exchanger, which breeds when the heat exchanger is wet.



Auto Cleaning

The automatic cleaning function dries the wet heat exchanger to prevent the bacteria from breeding mould. It eliminates the odour from air conditioners and can reduce the hassle of having to frequently clean the filter.



Wall Mounted Artcool & Health+

Detachable Bottom Cover

It is not necessary to disassemble or additionally support units thanks to the detachable chassis and support.

With LG's patented support the installation can be completed by only one individual

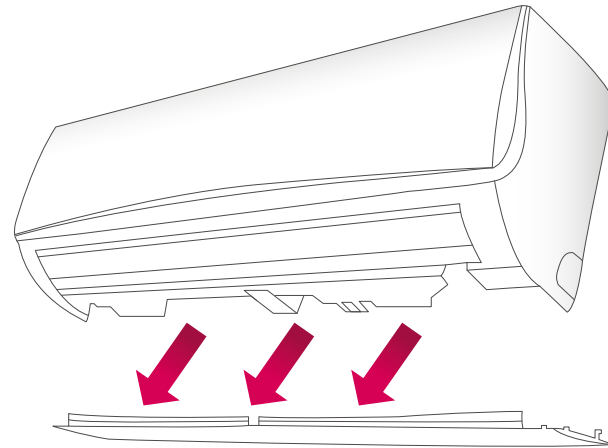

Installation Support Clip

A support clip creates adequate space between the wall and the unit for easier installation.

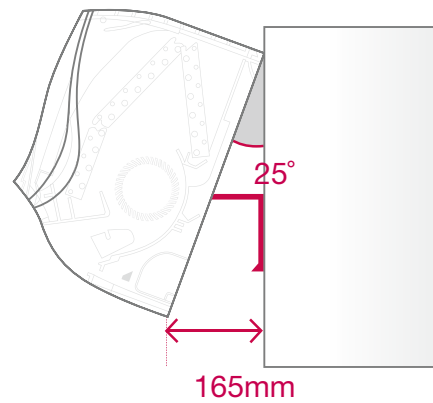

Wider Tubing Space

The tubing space is up to 45% wider than previous models for easier installation.

The tubing space is wider than many products currently on the market.

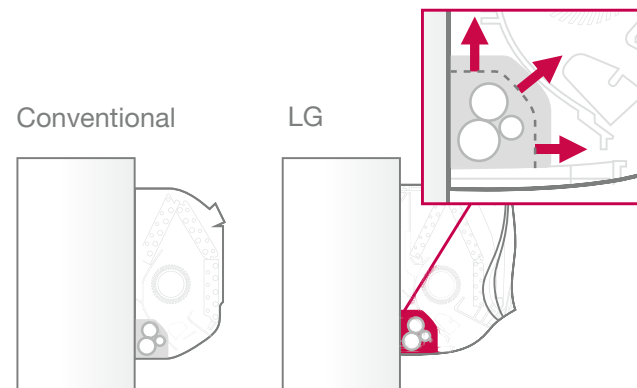

Various Indoor Units

Capacity (kBtu / kW)	9 / 2.6	12 / 3.5	18 / 5.3	24 / 7.0
Health+	AMNC09GDBA2	AMNC12GDBA2	AMNC18GDCA2	AMNC24GDCA2
ART COOL	AMNC09GDBR0. RRO	AMNC12GDBR0. RRO	AMNC18GDBR0. RRO	AMNC24GDBR0. RRO
	AMNC09GDBW0. RW	AMNC12GDBW0. RW	AMNC18GDBW0. RW	AMNC24GDBW0. RW

ARTCOOL Note : *Indicates panel color Mirror(R), White(W)

Specifications

Indoor Unit			AMNC09GDBA2	AMNC12GDBA2	AMNC18GDCA2	AMNC24GDCA2
Power Supply	V/Ø/Hz		220-240 / 1 / 50/60	220-240 / 1 / 50/60	220-240 / 1 / 50/60	220-240 / 1 / 50/60
Nominal Capacity	Nominal	kW Class	2.6	3.5	5.3	7.0
	Nominal	Btu/h Class	9,000	12,000	18,000	24,000
Running Current		A	0.15	0.15	0.28	0.28
Casing Color			White	White	White	White
Dimensions	Body (WxHxD)	mm	895 × 289 × 215	895 × 289 × 215	1,030 × 325 × 255	1,030 × 325 × 255
Net Weight	Body	kg (lbs)	11.0 (24.3)	11.0 (24.3)	13.0 (28.7)	13.0 (28.7)
Fan	Air Flow Rate (H/M/L)	m³/min	7.0 / 6.5 / 6.0	9.5 / 9.0 / 8.5	16.2 / 14.2 / 12.3	20.4 / 17.0 / 13.2
Fan Motor	Type		BLDC	BLDC	BLDC	BLDC
Sound Pressure Level (H/M/L)		dB (A)	33 / 30 / 27	39 / 36 / 31	37 / 33 / 28	42 / 39 / 36
Piping Connections	Liquid	mm (inch)	Ø 6.35 (1/4)	Ø 6.35 (1/4)	Ø 6.35 (1/4)	Ø 6.35 (1/4)
	Gas	mm (inch)	Ø 9.52 (3/8)	Ø 9.52 (3/8)	Ø 12.7 (1/2)	Ø 12.7 (1/2)
	Drain (O.D/I.D.)	mm	Ø 21.5 / 16.0	Ø 21.5 / 16.0	Ø 21.5 / 16.0	Ø 21.5 / 16.0

Note :

1. Wiring cable size must comply with the applicable local and national code.
2. Due to our policy of innovation some specifications may be changed without notification.

Indoor Unit			AMNC09GDBR0	AMNC12GDBR0	AMNC18GDBR0	AMNC24GDBR0
Power Supply	V/Ø/Hz		220-240 / 1 / 50/60	220-240 / 1 / 50/60	220-240 / 1 / 50/60	220-240 / 1 / 50/60
Nominal Capacity	Nominal	kW Class	2.6	3.5	5.3	6.7
	Nominal	Btu/h Class	9,000	12,000	18,000	23,000
Running Current		A	0.15	0.15	0.28	0.28
Casing Color			Grace Dark Gray	Grace Dark Gray	White	White
Dimensions	Body (WxHxD)	mm	895 × 289 × 205	895 × 289 × 205	1,030 × 325 × 245	1,030 × 325 × 245
Net Weight	Body	kg (lbs)	11.0 (24.3)	11.0 (24.3)	15.5 (34.2)	15.5 (34.2)
Fan	Air Flow Rate (H/M/L)	m³/min	7.0 / 6.5 / 6.0	9.5 / 9.0 / 8.5	12.0 / 10.0 / 8.2	14.2 / 12.0 / 10.2
Fan Motor	Type		BLDC	BLDC	BLDC	BLDC
Sound Pressure Level (H/M/L)		dB (A)	33 / 30 / 27	39 / 36 / 31	37 / 33 / 28	42 / 39 / 36
Piping Connections	Liquid	mm (inch)	Ø 6.35 (1/4)	Ø 6.35 (1/4)	Ø 6.35 (1/4)	Ø 6.35 (1/4)
	Gas	mm (inch)	Ø 9.52 (3/8)	Ø 9.52 (3/8)	Ø 12.7 (1/2)	Ø 12.7 (1/2)
	Drain (O.D/I.D.)	mm	Ø 21.5 / 16.0	Ø 21.5 / 16.0	Ø 21.5 / 16.0	Ø 21.5 / 16.0

Note :

1. Wiring cable size must comply with the applicable local and national code.
2. Due to our policy of innovation some specifications may be changed without notification.

Indoor Unit			AMNC09GDBW0	AMNC12GDBW0	AMNC18GDBW0	AMNC24GDBW0
Power Supply	V/Ø/Hz		220-240 / 1 / 50/60	220-240 / 1 / 50/60	220-240 / 1 / 50/60	220-240 / 1 / 50/60
Nominal Capacity	Nominal	kW Class	2.6	3.5	5.3	6.7
	Nominal	Btu/h Class	9,000	12,000	18,000	23,000
Running Current		A	0.15	0.15	0.28	0.28
Casing Color			Grace Dark Gray	Grace Dark Gray	White	White
Dimensions	Body (WxHxD)	mm	895 × 289 × 205	895 × 289 × 205	1,030 × 325 × 245	1,030 × 325 × 245
Net Weight	Body	kg (lbs)	11.0 (24.3)	11.0 (24.3)	15.5 (34.2)	15.5 (34.2)
Fan	Air Flow Rate (H/M/L)	m³/min	7.0 / 6.5 / 6.0	9.5 / 9.0 / 8.5	12.0 / 10.0 / 8.2	14.2 / 12.0 / 10.2
Fan Motor	Type		BLDC	BLDC	BLDC	BLDC
Sound Pressure Level (H/M/L)		dB (A)	33 / 30 / 27	39 / 36 / 31	37 / 33 / 28	42 / 39 / 36
Piping Connections	Liquid	mm (inch)	Ø 6.35 (1/4)	Ø 6.35 (1/4)	Ø 6.35 (1/4)	Ø 6.35 (1/4)
	Gas	mm (inch)	Ø 9.52 (3/8)	Ø 9.52 (3/8)	Ø 12.7 (1/2)	Ø 12.7 (1/2)
	Drain (O.D/I.D.)	mm	Ø 21.5 / 16.0	Ø 21.5 / 16.0	Ø 21.5 / 16.0	Ø 21.5 / 16.0

Note :

1. Wiring cable size must comply with the applicable local and national code.
2. Due to our policy of innovation some specifications may be changed without notification.

Ceiling Cassettes

Wide Air Flow

Improved vanes reduce the curved area and provide better air and temperature distribution.

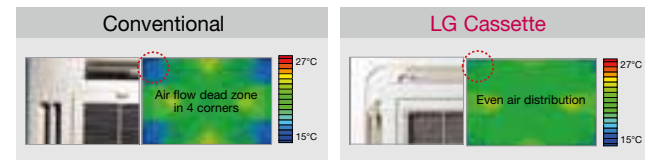

Independent Vane Control

It is possible to control each of the 4 vanes individually as the motors are connected separately to each vane.

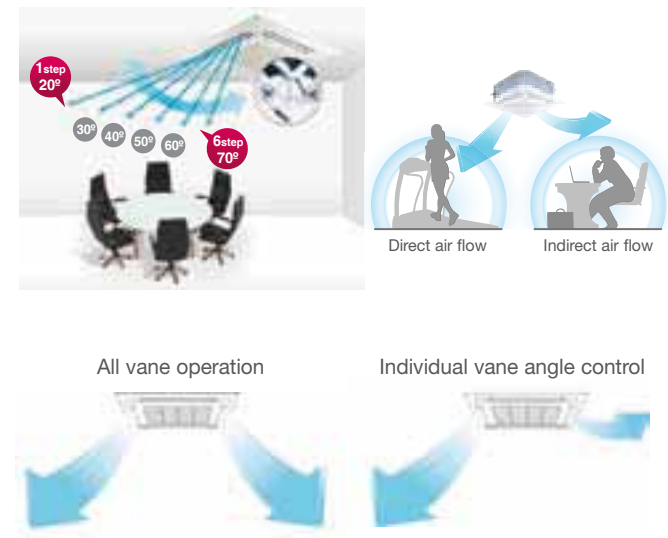

* Wired remote controller PQRVSL0(QW) applied

Convenient Panel Installation

The detachable corner design makes it easy to adjust the hanger during installation and to check for leakages in the drain connection pipe.

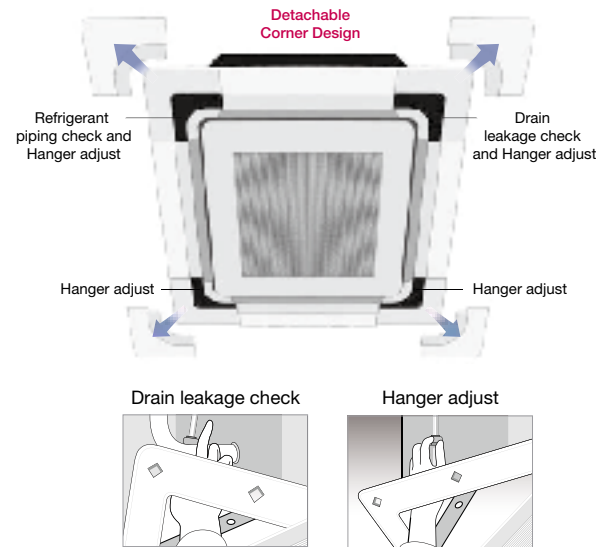

It is easy to install the panel to the body, using the button type panel design.



Auto Elevation Grille

Easy filter cleaning with elevation grill

- Installation inside main body
- Auto horizontal control
- 4 points support structure
- Memory for user's level
- Max 4.5m length
- Model : PTEGM0

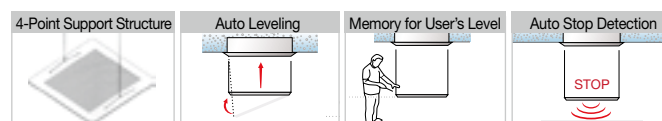

* Operating with wired remote controller PQRVSL0(QW) and wireless remote controller included in PTEGM0.

* Except CT09 NR2 / CT12 NR2 / CT18 NQ2

Various Indoor Units

Capacity (kBtu / kW)	12 / 3.5	18 / 5.3	24 / 7.0
4-Way Cassette Type	AMNC12GTRA2	AMNC18GTQA2	AMNC24GTPA2

Specifications

Indoor Unit		AMNC12GTRA2	AMNC18GTQA2	AMNC24GTPA2
Power Supply	V/Ø/Hz	220-240 / 1 / 50/60	220-240 / 1 / 50/60	220-240 / 1 / 50/60
Nominal Capacity	Nominal kW Class	3.50	5.30	7.00
	Nominal Btu/h Class	12,000.00	18,000.00	24,000.00
Running Current	A	0.35	0.43	0.6
Dimensions	Body (WxHxD)	mm 570 x 214 x 570	570 x 256 x 570	840 x 204 x 840
Net Weight	Body	kg (lbs) 14.0 (30.9)	15.0 (33.1)	21.0 (46.3)
Fan	Air Flow Rate (H/M/L)	m³/min 9.5 / 8.0 / 6.5	13.0 / 12.0 / 10.0	17.0 / 15.0 / 13.0
Fan Motor	Type	BLDC	BLDC	BLDC
Sound Pressure Level (H/M/L)	dB (A)	35 / 31 / 27	40 / 37 / 34	39 / 37 / 34
	Liquid	mm (inch) Ø 6.35 (1/4)	Ø 6.35 (1/4)	Ø 6.35 (1/4)
Piping Connections	Gas	mm (inch) Ø 9.52 (3/8)	Ø 12.7 (1/2)	Ø 12.7 (1/2)
	Drain (O.D./I.D.)	mm Ø 32.0 / 25.0	Ø 32.0 / 25.0	Ø 32.0 / 25.0
Decoration Panel	Model Name	PT-UQC	PT-UQC	PT-UMC
	Casing color	Morning Fog	Morning Fog	Morning Fog
	Dimensions (WxHxD)	mm 700 x 22 x 700	700 x 22 x 700	950 x 25 x 950
	Net Weight	kg (lbs) 3.0 (6.6)	3.0 (6.6)	5.0 (11.0)

Note :

1. Wiring cable size must comply with the applicable local and national code.
2. Due to our policy of innovation some specifications may be changed without notification.

Ceiling Concealed Ducts

E.S.P. Control

The BLDC motor and low noise fan means that air volume can be easily controlled by using the wired remote controller. The BLDC motor can control the fan speed and air volume regardless of the external static pressure(E.S.P.) With E.S.P control no additional accessories are needed to adjust the air flow and the energy consumption of the fan is also reduced.

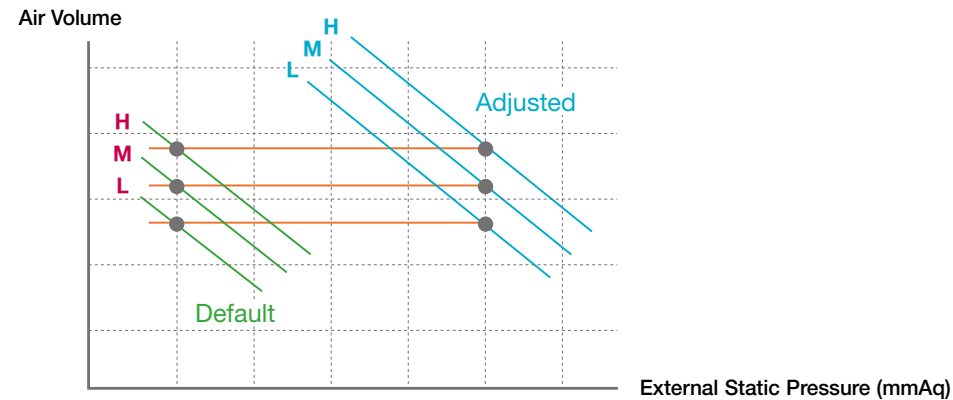

External Static Pressure (mmAq)
* Wired remote controller PQRCVSL0(QW) applied.

Two Thermistors Control

The indoor temperature can be checked using the thermistors in the remote controller as well as from the indoor unit. There may be a significant difference between ceiling and floor air temperature. Two thermistors can optimise indoor air temperature for a more comfortable environment.

Compares temperatures sensed from different positions, and automatically selects the optimum temperature for users



<PQRCVSL0QW>

Remote Controller Thermistor



Operation for Multiple Rooms

Using a spiral duct (embedded or flexible type) and stream chamber, it is possible to operate cooling/heating for several rooms simultaneously.

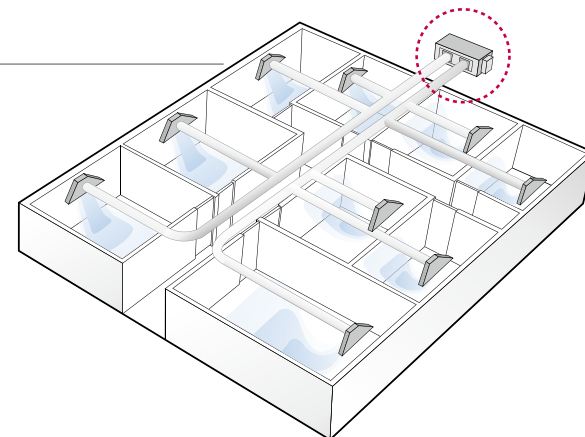

Various Indoor Units

Capacity (kBtu / kW)	12 / 3.5	18 / 5.3	24 / 7.0
Low Static Duct	AMNC12GB1A2	AMNC18GB2A2	AMNC24GB2A2
High Static Duct		AMNC18GBHA2	AMNC24GBHA2

Specifications

Indoor Unit			AMNC12GB1A2	AMNC18GB2A2	AMNC24GB2A2
Power Supply	V/Ø/Hz		220 - 240 / 1 / 50 / 60	220 - 240 / 1 / 50 / 60	220 - 240 / 1 / 50 / 60
Nominal Capacity	Nominal	kW Class	3.5	5.3	7.0
	Nominal	Btu/h Class	12000	18,000	24,000
Running Current		A	1	1.60	1.60
Dimensions	Body (WxHxD)	mm	820 × 190 × 575	1,100 × 190 × 575	1,100 × 190 × 575
	Net Weight	Body	kg (lbs)	20.5 (45.2)	25.0 (55.1)
Fan	Air Flow Rate (H/M/L)	m³/min	9.5 / 8.5 / 7.5	15.0 / 13.5 / 11.5	17.0 / 15.0 / 13.5
	High-static mode (Factory Set)				
	External Static Pressure	Pa (mmAq)	39 (4)	39 (4)	39 (4)
Fan Motor	Type		BLDC	BLDC	BLDC
Sound Pressure Level (H/M/L)		dB(A)	33 / 31 / 26	34 / 31 / 29	36 / 34 / 32
	Liquid	mm (inch)	Ø 6.35 (1/4)	Ø 6.35 (1/4)	Ø 6.35 (1/4)
Piping	Gas	mm (inch)	Ø 9.52 (3/8)	Ø 12.7 (1/2)	Ø 12.7 (1/2)
	Connections	Drain (O.D/I.D.)	mm	Ø 32.0 / 25.0	Ø 32.0 / 25.0

Note :
1. Wiring cable size must comply with the applicable local and national code.
2. Due to our policy of innovation some specifications may be changed without notification.

Indoor Unit			AMNC18GBHA2	AMNC24GBHA2
Power Supply	V/Ø/Hz		220 - 240 / 1 / 50 / 60	220 - 240 / 1 / 50 / 60
Nominal Capacity	Nominal	kW Class	5.3	7.0
	Nominal	Btu/h Class	18,000	24,000
Running Current		A	1.00	1.10
Dimensions	Body (WxHxD)	mm	882 × 260 × 450	882 × 260 × 450
	Net Weight	Body	kg (lbs)	26.0 (57.3)
Fan	Air Flow Rate (H/M/L)	m³/min	16.5/14.5/13.0	18.0 / 16.5 / 14.0
	High-static mode (Factory Set)			
	External Static Pressure	Pa (mmAq)	78 (8)	78 (8)
Fan Motor	Type		BLDC	BLDC
Sound Pressure Level (H/M/L)		dB(A)	36 / 34 / 32	36 / 34 / 32
Piping	Liquid	mm (inch)	Ø 6.35 (1/4)	Ø 6.35 (1/4)
	Gas	mm (inch)	Ø 12.7 (1/2)	Ø 12.7 (1/2)
Connections	Drain (O.D/I.D.)	mm	Ø 32.0 / 25.0	Ø 32.0 / 25.0



Note :
1. Wiring cable size must comply with the applicable local and national code.
2. Due to our policy of innovation some specifications may be changed without notification.

Accessories

BD (Branch distributor box) Units

PMBD3620, PMBD3630, PMBD3640

Easy installation using Distributors.

For	2 Indoors	3 Indoors	4 Indoors
Distributor	 PMBD3620	 PMBD3630	 PMBD3640
Various distributors can make much easier installation for any sites			

Features

- Distribution of refrigerant to various indoor units.
- 3 models (2, 3, 4 indoor units)
- EEV included
- Controlling PCB inside the unit
- Internally insulated (prevents any chances of drainage)
- Flare joints for easy and clean installation
- Compact design (low height)
- Flexible installation



Specifications_Distributor Boxes

		PMBD3620	PMBD3630	PMBD3640
Connectable Indoor Units	Number of Indoor Units	1~2	1~3	1~4
	Capacity	9k / 12k / 18k / 24k	9k / 12k / 18k / 24k	9k / 12k / 18k / 24k
Power Source	φ/Hz/V	1,50, 220 ~ 240	1,50, 220 ~ 240	1,50, 220 ~ 240
Power Consumption	W	10	10	10
Running Current	A	0.05	0.05	0.05
Dimensions	WxHxD	mm(inch) 302 × 143 × 252(11.9 × 5.6 × 9.9)	302 × 143 × 252(11.9 × 5.6 × 9.9)	302 × 143 × 252(11.9 × 5.6 × 9.9)
Net Weight	kg	5.9	6.5	7.1
Piping Connection (To Outdoor Unit)	Liquid	mm(inch) φ 9.52(3/8)	φ 9.52(3/8)	φ 9.52(3/8)
	Gas	mm(inch) φ 19.05(3/4)	φ 19.05(3/4)	φ 19.05(3/4)
Piping Connection (To Indoor Unit)	Liquid	mm(inch) φ 6.35(1/4) × 2EA	φ 6.35(1/4) × 3EA	φ 6.35(1/4) × 4EA
	Gas	mm(inch) φ 9.52(3/8) × 2EA	φ 9.52(3/8) × 3EA	φ 9.52(3/8) × 4EA
Accessories	Hanger (Bracket)	EA 4	4	4
	Screw	EA 8	8	8
	Manual	EA 1	1	1



- Note :
1. BD unit or Indoor Unit Max. Height <--> BD unit or Indoor Unit Min. Height : Max.10m
Set up the BD unit and Indoor Unit in 15m.
 2. The piping connection must be suit the piping sizes of the indoor unit which will be connected.
(If need, use the connector which is included in the indoor unit)
 3. The BD should be installed inside the building.
 4. Wiring cable size must comply with the applicable local and national code.

Y Branch and Branch Kit

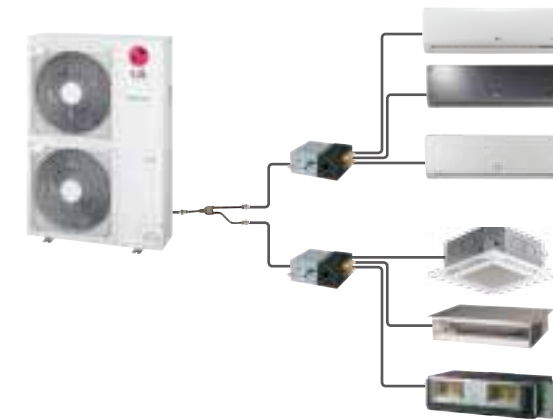
Application

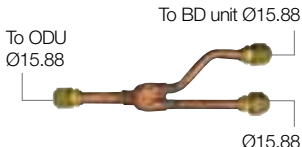

Accessory model name

Branch Type	No. of BD Units	Accessory Model Name	Applicable Model	Specification (Unit : mm)	
				Gas	Liquid
Y-Branch	2	PMBL 4820	MULTI F DX		

Features

- Y Branch and Branch kit make MULTI Fdx installation much easier.
- Y Branch and Branch kit for both gas and liquid are provided.
- Insulation material is also provided for covering the branches.

SINGLE INVERTER



Why LG Single Inverter?

LG inverter technology controls the speed of the motor and the compressor simultaneously. By eliminating stop-start cycles, efficiency is significantly increased, extending the life of individual components. Ultimately, with the help of such advanced technology, Inverter air conditioners are less prone to breakdown, cheaper to run and the outdoor compressor is generally quieter than conventional air conditioners. LG revolutionary Inverter technology boasts powerful silent performance while minimizing energy consumption by as much as up to 40%.



Comfortable Operation

Once the desired temperature is achieved, unlike conventional air conditioners that turn the compressor on and off, LG inverter units adjust and constantly vary the compressor speed to maintain the desired temperature with minimal fluctuation to ensure that your comfort is not compromised.

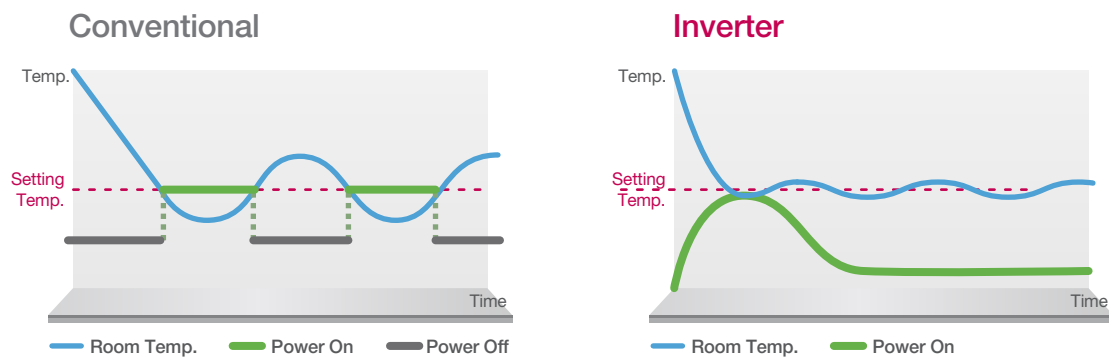

Ceiling Cassette



	Btu	18,000	21,000	24,000	36,000	42,000	48,000	54,000
	kW	5.0	6.0	7.0	10.0	12.5	14.0	15.8
Indoor Unit		ATNQ18GPLE3	ATNQ21GPLE3	ATNQ24GNLE3	ATNQ36GMLE3	ATNQ42GMLE3	ATNQ48GMLE3	ATNQ54GMLE3
Dimension		840*840*204	840*840*204	840*840*246	840*840*288	840*840*288	840*840*288	840*840*288
Outdoor Unit		ATNQ18GPLE3	ATNQ21GPLE3	ATNQ24GNLE3	ATNQ36GMLE3	ATNQ42GMLE3	ATNQ48GMLE3	ATNQ54GMLE3
Dimension		770*545*288	770*545*288	870*655*320	950*834*330	950*834*330	950*834*330	950*1380*330

Ceiling Concealed Duct (Low Static)



	Btu	18,000	21,000	24,000
	kW	5.0	5.8	7.0
Indoor Unit		ABNQ18GL2A0	ABNQ21GL2A0	ABNQ24GL3A0
Dimension		950*220*650	950*220*650	1100*220*650
Outdoor Unit		ABUQ18GL2A0	ABUQ21GL2A0	ABUQ24GL3A0
Dimension		770*545*288	770*545*288	870*655*320

Ceiling Concealed Duct (Middle Static)



	Btu	18,000	21,000	24,000	36,000	42,000	48,000	54,000
	kW	5.0	6.0	7.0	10.0	12.5	14.0	15.8
Indoor Unit		ABNQ18GHLA0	ABNQ21GHLA0	ABNQ24GGLA0	ABNQ36GGLA0	ABNQ42GRLA0	ABNQ48GRLA0	ABNQ54GRLA0
Dimension		840*840*450	840*840*204	1180*298*450	180*298*450	1230*380*590	1230*380*590	1230*380*590
Outdoor Unit		ABUQ18GHLA0	ABUQ21GHLA0	ABUQ24GGLA0	ABUQ36GGLA0	ABUQ42GRLA0	ABUQ48GRLA0	ABUQ54GRLA0
Dimension		770*545*288	770*545*288	870*655*320	950*834*330	950*834*330	950*834*330	950*1380*330

Ceiling Suspended



	Btu	18,000	21,000	24,000	36,000	42,000	48,000	54,000
	kW	5.0	5.8	7.0	10.0	12.5	14.0	15.8
Indoor Unit		AVNQ18GJLA0	AVNQ21GJLA0	AVNQ24GJLA0	AVNQ36GKLA0	AVNQ42GLLA0	AVNQ48GLLA0	AVNQ54GLLA0
Dimension		950*220*650	950*220*650	950*220*650	1350*220*650	1750*220*650	1750*220*650	1750*220*650
Outdoor Unit		ATNQ18GPLE3	ATNQ21GPLE3	ATNQ24GNLE3	ATNQ36GMLE3	ATNQ42GMLE3	ATNQ48GMLE3	ATNQ54GMLE3
Dimension		770*545*288	770*545*288	870*655*320	950*834*330	950*834*330	950*834*330	950*1380*330

Excellent Energy Saving

Seasonal Efficiency

New Measurement of air conditioning energy efficiency which is conducted in various environmental conditions



Quick Cooling

Optimized Pressure Control

Pressure sensor which is added to the temperature control secures quick cooling & wide operating range

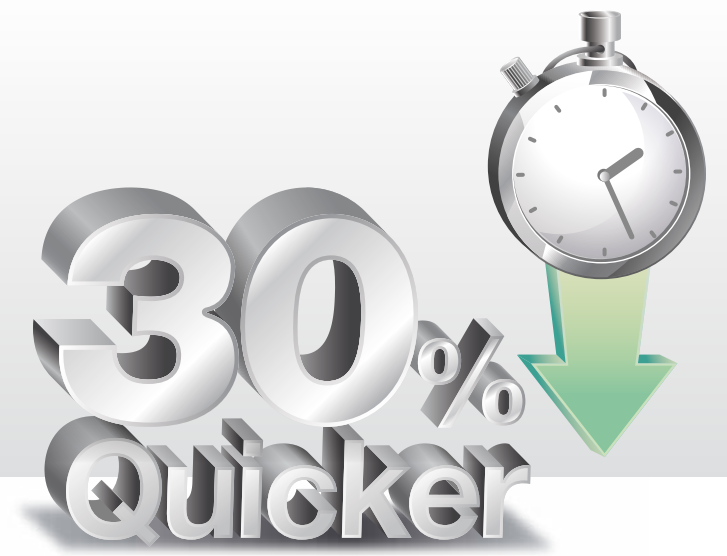

Cassette



Power Consumption (Annual)

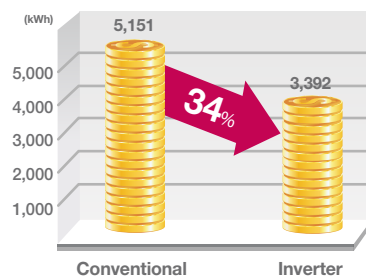

Payback Period

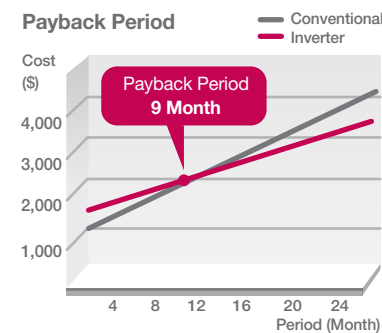

Duct



Power Consumption (Annual)

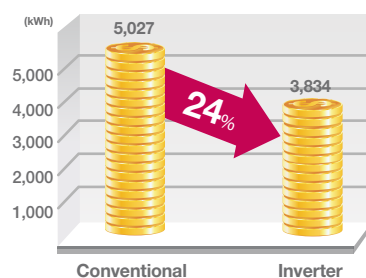

Payback Period

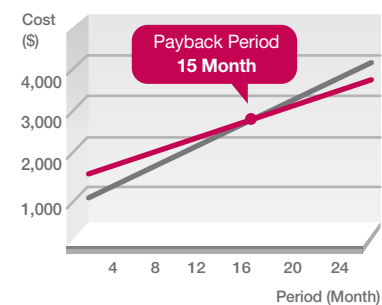

Convertible



Power Consumption (Annual)

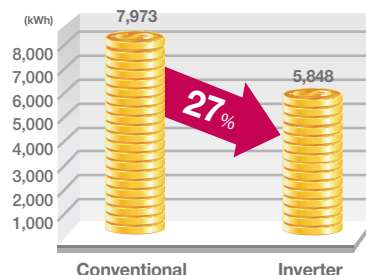

Payback Period

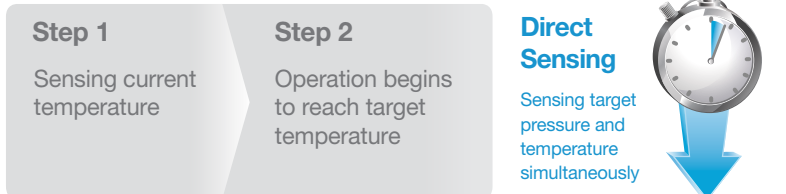
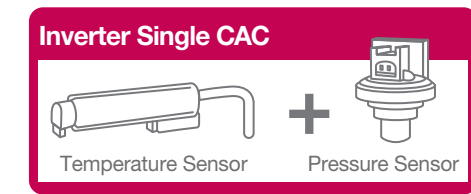
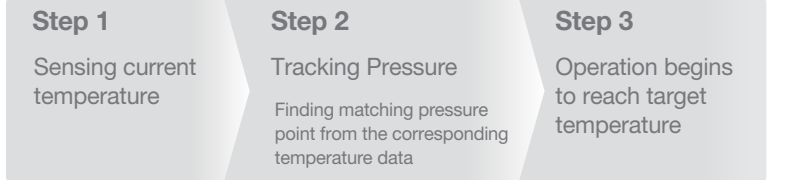
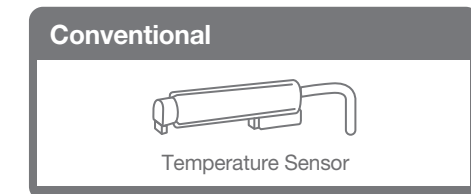
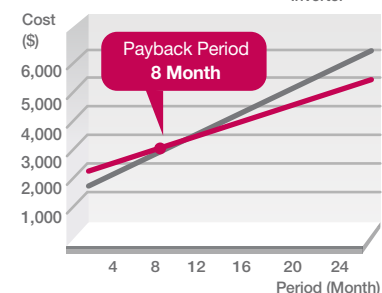

Shorten Time to Reach Setting Temp.

Pressure Control takes up to 30% less time to reach the desired temperature with a high level of accuracy and stability.

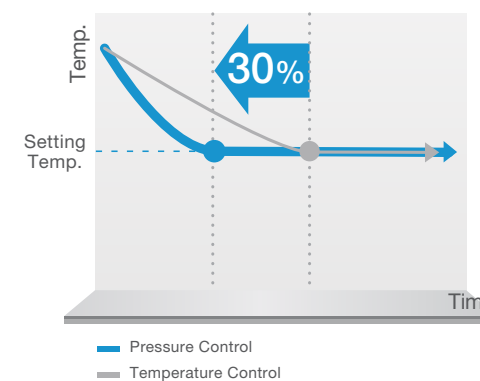

Wide Operating Range

Continuous Operation Range: -15°C ~ 48°C

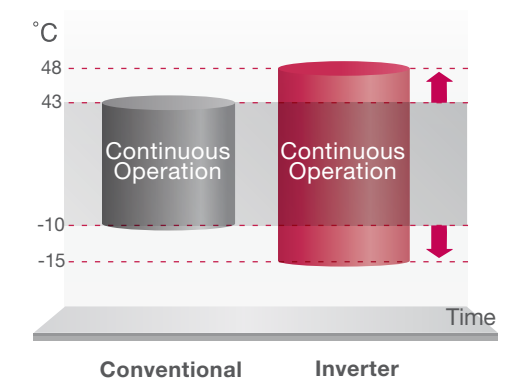

1. Calculation based on regional temperature condition in Panama City
 2. Operation duration: 9 hours/day (09:00 - 18:00) & 6 days/week
 3. Electric charge: 0.3\$ / kWh
 4. Initial cost: product price + installation cost

Quiet Operation

Reduced Sound Level

BLDC motor and high efficiency indoor fan remove abnormal noise and improve sound quality

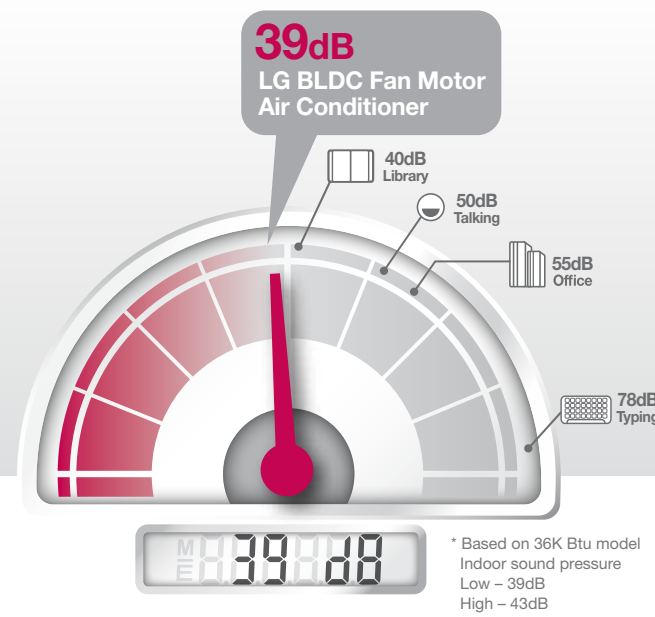

Easy Installation

Space Saving

18~48Kbtu Outdoor Units are lined up with only 1 Fan type.
(54K btu unit is consist of 2 fan type)



Improved Outdoor Fan

The New Axial Fan has thick front edge and smooth rear edge, providing high efficiency with low noise and wide fan, as well as high air flow rate and increased fan operation.

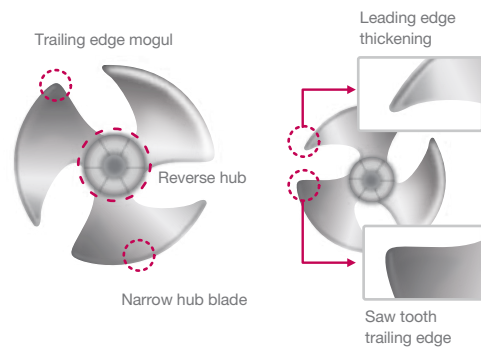

BLDC Fan Motor

The LG BLDC fan motor offers additional energy saving in operating mode up to 40% at low speed, 20% at high speed compared to AC motor.

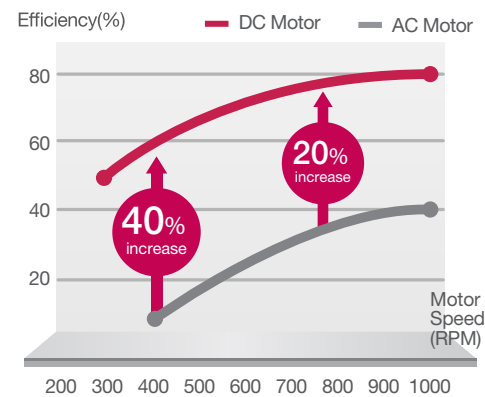

Compact Outdoor Unit

1 fan-type of outdoor unit makes you save more space and easier to install

Capacity	18k Btu/h	21k Btu/h	24k Btu/h	36k Btu/h	42k Btu/h	48k Btu/h	54k Btu/h
Conventional Outdoor (Inverter)	UE	U4	OU4	U3			
Volume reduce rate (vs. conventional)	34%	30%	30%	40%			
New SCAC Outdoor (Inverter)	UL2	UE	U4	U3			

*Dimension (mm)
UL2 770x545x288 UE 870 x 655 x 320 U4 950 x 834 x 330 OU4 950 x 1170 x 330 U3 950 x 1380 x 330

Easy to Carry

Fitted hand grips for easy transportation and installation

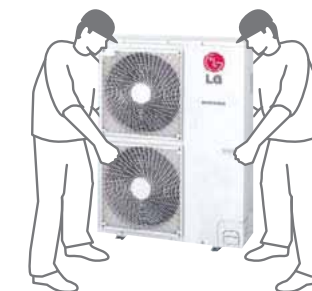

Superior Reliability & Comfort

Ceiling Cassette



Compact Size

Ultra slim & compact design not only saves space but, also reduces installation cost. It's designed to suit most of building designs and fit into space

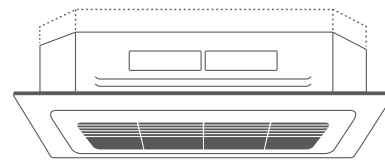

Length Width : 840X840mm

Model	Height
18~21k Btu/h	204 mm
24k Btu/h	246 mm
36-54k Btu/h	288 mm



4 Way Independent Adjustable Vane

It memorizes wind direction setting and always blow optimal wind for various users. (Individual vane control is available from 20°~70°)

* This function is available with wired remote controller (PQRCVSL0Q)

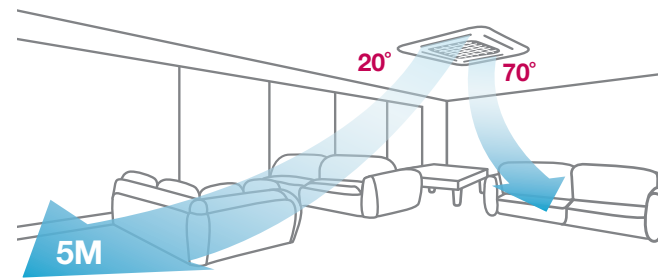

High Ceiling Mode

High ceiling mode provides powerful cooling and heating up to 4.2m in height, from ceiling floor.

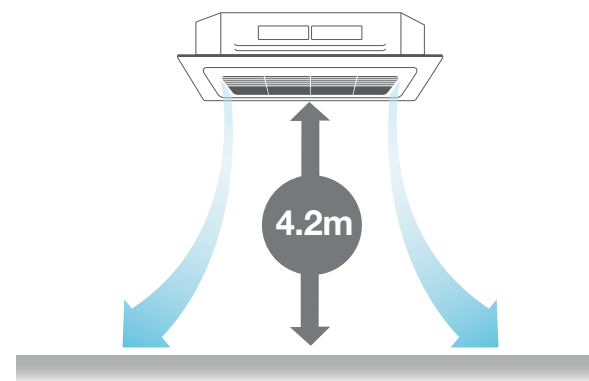

Duct



E.S.P : External Static Pressure Control

The BLDC motor can control the fan speed and air volume regardless of the external static pressure.

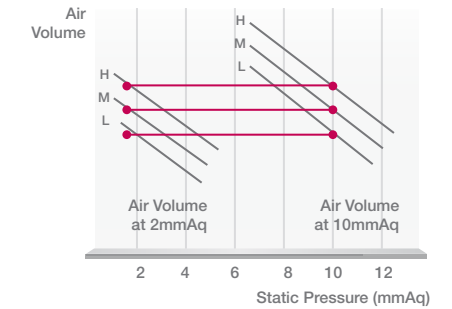

Easy to Change the Filter for Low Static Duct

Clip design prevents conflict with walls in narrow installation space.

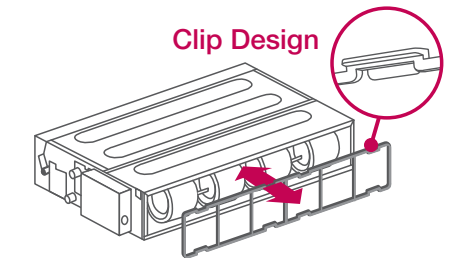

Operation for Multiple Rooms for Middle Static Duct

Using a spiral duct (embedded or flexible type) and stream chamber, it is possible to operate cooling for several room simultaneously.

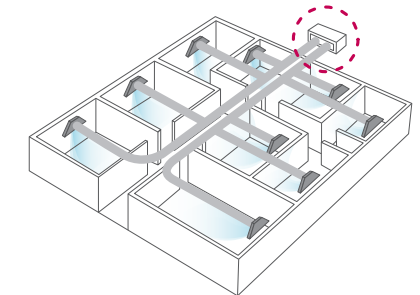

Convertible



Airflow Direction Control

The air flow direction can be adjusted as desired by using the remote controller. This is effective when you want to cool yourself directly

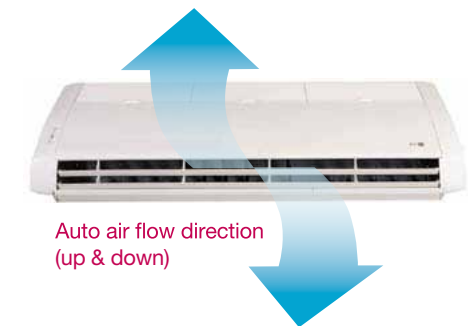

One Touch Filter

Whenever filter is need to be cleaned, it will be notified by the alarm and clean air can be maintained by cleaning the filter. Due to one touch feature, it's very easy and convenient to clean the filter.



Ceiling Cassette



Indoor Unit Model				ATNQ18GPLE3	ATNQ21GPLE3
Capacity	Cooling	Min	kW		
		Rated	kW	5.0	6.0
		Max	kW		
Running Current (Set)		Rated	A	6.3	8.1
Power Supply			∅V/Hz	1 / 220-240 / 50/60	1 / 220-240 / 50/60
EER				3.45	3.23
Air Flow Rate	Low	m ³ /min		13.0	16.0
	Medium	m ³ /min		15.0	18.0
	High	m ³ /min		17.0	20.0
Sound Pressure	Low	dBA		32	36
	Medium	dBA		34	38
	High	dBA		36	40
Dimension	Body	W*H*D	mm	840*204*840	840*204*840
	Packing	W*H*D	mm	922*276*917	922*276*917
Net weight	Net		kg	20.5	20.5
	Gross		kg	25	25
Piping connection	Liquid		mm(inch)	6.35 (1/4)	6.35 (1/4)
	Gas		mm(inch)	12.7 (1/2)	12.7 (1/2)
	Drain	O.D/I.D	mm	32.0 / 25.5	32.0 / 25.5
Decoration Panel	Model			PT-UMC	PT-UMC
	Color			Morning Fog	Morning Fog
	Dimensions	H*D*W	mm	25*950*950	25*950*950
	Weight		kg	5.0	5.0



Outdoor Unit Model				ATUQ18GPLE3	ATUQ21GPLE3
Capacity	Cooling	Min	kW		
		Rated	kW	5.0	6.0
		Max	kW		
Power Input		Rated	kW	1.45	1.86
Compressor		Type		Twin Rotary	Twin Rotary
Airflow Rate			m ³ /min	50	50
Sound Pressure		Cooling	dBA	47	47
Dimensions	Body	W*H*D	mm	770*545*288	770*545*288
	Packing	W*H*D	mm	920*585*388	920*585*388
Net weight	Net		kg	36	36
	Gross		kg	38.3	38.3
Refrigerant	Type			R410A	R410A
	Charge		g	900	900
Additional Refrigerant charge			g/m	20	40
Operation Range (outdoor)		Min~Max	∅DB	-15~-48	-15~-48
Power Supply			∅V/Hz	1 / 220-240 / 50/60	1 / 220-240 / 50/60
Power Supply Cable			N*mm ²	3*2.5	3*2.5
Transmission Cable			N*mm ²	4*0.75	4*0.75
Circuit Breaker			A	20	20
Piping Length total	Min	m		5	5
	Max	m		30	30
Piping elevation difference	IDU-ODU	Max	m	15	15
	Liquid		mm(inch)	6.35 (1/4)	6.35 (1/4)
Piping connection	Gas		mm(inch)	12.7 (1/2)	12.7 (1/2)

Note : 1. Capacities are based on the following conditions Cooling : Indoor Temperature 27°C DB / 19°C WB / Outdoor Temperature 35°C DB / 24°C WB
Heating : Indoor Temperature 20°C DB / 15°C WB / Outdoor Temperature 7°C DB / 6°C WB

2. Annual energy consumption based on average use of 500 running hours per year at Ratedinal condition

* Due to our policy of innovation some specifications may be changed without notification.



ATNQ24GNLE3	ATNQ36GMLE3	ATNQ42GMLE3	ATNQ48GMLE3	ATNQ54GMLE3
7.0	10.0	12.5	13.4	15.8
8.3	12.6	16.2	19.3	22.7
1 / 220-240 / 50/60	1 / 220-240 / 50/60	1 / 220-240 / 50/60	1 / 220-240 / 50/60	1 / 220-240 / 50/60
3.65	3.45	3.35	3.02	3.02
19.0	26.0	28.0	28.0	28.0
21.0	28.0	30.0	30.0	30.0
23.0	30.0	32.0	32.0	32.0
36	39	40	40	40
38	41	42	42	42
40	43	44	44	44
840*246*840	840*288*840	840*288*840	840*288*840	840*288*840
922*318*917	922*360*917	922*360*917	922*360*917	922*360*917
22.3	24.6	28	28	28
27	29	33	33	33
9.52 (3/8)	9.52 (3/8)	9.52 (3/8)	9.52 (3/8)	9.52 (3/8)
15.88 (5/8)	15.88 (5/8)	15.88 (5/8)	15.88 (5/8)	19.05 (3/4)
32.0 / 25.5	32.0 / 25.5	32.0 / 25.5	32.0 / 25.5	32.0 / 25.5
PT-UMC	PT-UMC	PT-UMC	PT-UMC	PT-UMC
Morning Fog	Morning Fog	Morning Fog	Morning Fog	Morning Fog
25*950*950	25*950*950	25*950*950	25*950*950	25*950*950
5.0	5.0	5.0	5.0	5.0



ATUQ24GNLE3	ATUQ36GMLE3	ATUQ42GMLE3	ATUQ48GMLE3	ATUQ54GMLE3
7.0	10.0	12.5	13.4	15.8
1.92	2.9	3.73	4.44	5.23
Twin Rotary	Twin Rotary	Twin Rotary	Twin Rotary	Twin Rotary
58	58	70	70	140
48	48	52	52	55
870*655*320	950*834*330	950*834*330	950*834*330	950*1380*330
1022*716*437	1040*918*461	1040*918*461	1040*918*461	1040*1462*461
44	65	67	67	96
48.1	71.8	73.8	73.8	107.1
R410A	R410A	R410A	R410A	R410A
1100	1900	2400	2400	3300
40	40	40	40	40
-15~-48	-15~-48	-15~-48	-15~-48	-15~-48
1 / 220-240 / 50/60	1 / 220-240 / 50/60	1 / 220-240 / 50/60	1 / 220-240 / 50/60	1 / 220-240 / 50/60
3*2.5	3*2.5	3*5.0	3*5.0	3*5.0
4*0.75	4*0.75	4*0.75	4*0.75	4*0.75
25	30	40	40	40
5	5	5	5	5
50	50	50	50	50
30	30	30	30	30
9.52 (3/8)	9.52 (3/8)	9.52 (3/8)	9.52 (3/8)	9.52 (3/8)
15.88 (5/8)	15.88 (5/8)	15.88 (5/8)	15.88 (5/8)	19.05 (3/4)

Note : 1. Capacities are based on the following conditions Cooling : Indoor Temperature 27°C DB / 19°C WB / Outdoor Temperature 35°C DB / 24°C WB
Heating : Indoor Temperature 20°C DB / 15°C WB / Outdoor Temperature 7°C DB / 6°C WB

2. Annual energy consumption based on average use of 500 running hours per year at Ratedinal condition

* Due to our policy of innovation some specifications may be changed without notification.

Ceiling Concealed Duct (Middle Static)



Indoor Unit Model			ABNQ18GHLA0	ABNQ21GHLA0
Capacity	Min	kW		
	Rated	kW	5.0	6.0
	Max	kW		
Running Current (Set)	Rated	A	6.7	8.7
Power Supply		∅V/Hz	1 / 220-240 / 50/60	1 / 220-240 / 50/60
EER			3.23	3.02
Air Flow Rate	Low	m ³ /min	13.0	14.0
	Medium	m ³ /min	14.5	16.5
	High	m ³ /min	16.5	18.0
Sound Pressure	Low	dBA	33	33
	Medium	dBA	35	35
	High	dBA	37	37
Dimension	Body	W*H*D	mm	880*260*450
	Packing	W*H*D	mm	1134*340*560
Net weight	Net	kg	26.0	26.0
	Gross	kg	30.1	30.1
Piping connection	Liquid	mm(inch)	6.35 (1/4)	6.35 (1/4)
	Gas	mm(inch)	12.7 (1/2)	12.7 (1/2)
	Drain	O.D/I.D	mm	25.4/20.4
External Static Pressure	Min~Max	Pa	25~80	25~80



Outdoor Unit Model			ABUQ18GHLA0	ABUQ21GHLA0
Capacity	Cooling	Min	kW	
		Rated	kW	5.0
		Max	kW	6.0
Power Input	Rated	kW	1.55	1.99
Compressor	Type		Twin Rotary	Twin Rotary
Airflow Rate		m ³ /min	50	50
Sound Pressure	Cooling	dBA	47	47
Dimensions	Body	W*H*D	mm	770*545*288
	Packing	W*H*D	mm	920*585*388
Net weight	Net	kg	36	36
	Gross	kg	38.3	38.3
Refrigerant	Type		R410A	R410A
	Charge	g	900	900
Additional Refrigerant charge		g/m	20	40
Operation Range (outdoor)	Min~Max	∅DB	-15~48	-15~48
Power Supply		∅V/Hz	1 / 220-240 / 50/60	1 / 220-240 / 50/60
Power Supply Cable		N*mm ²	3*2.5	3*2.5
Transmission Cable		N*mm ²	4*0.75	4*0.75
Circuit Breaker		A	20	20
Piping Length total	Min	m	5	5
	Max	m	30	30
Piping elevation difference	IDU-ODU	Max	m	15
Piping connection	Liquid	mm(inch)	6.35 (1/4)	6.35 (1/4)
	Gas	mm(inch)	12.7 (1/2)	12.7 (1/2)

Note : 1. Capacities are based on the following conditions Cooling : Indoor Temperature 27°C DB / 19°C WB / Outdoor Temperature 35°C DB / 24°C WB
Heating : Indoor Temperature 20°C DB / 15°C WB / Outdoor Temperature 7°C DB / 6°C WB

2. Annual energy consumption based on average use of 500 running hours per year at Ratedinal condition

* Due to our policy of innovation some specifications may be changed without notification.



ABNQ24GGLA0	ABNQ36GGLA0	ABNQ42GRLA0	ABNQ48GRLA0	ABNQ54GRLA0
7.0	10.0	12.5	13.4	15.8
9.4	14.4	16.9	19.3	21.3
1 / 220-240 / 50/60	1 / 220-240 / 50/60	1 / 220-240 / 50/60	1 / 220-240 / 50/60	1 / 220-240 / 50/60
3.23	3.02	3.22	3.02	3.22
20.0	26.0	30.0	30.0	40.0
23.0	29.0	35.0	35.0	45.0
26.5	32.0	40.0	40.0	50.0
36	36	40	40	42
39	39	42	42	44
42	42	44	44	46
1180*298*450	1180*298*450	1230*380*590	1230*380*590	1230*380*590
1436*380*579	1436*380*579	1484*456*695	1484*456*695	1484*456*695
33.0	35.0	52.0	52.0	49.0
38.4	41.5	58.5	58.5	55.5
9.52 (3/8)	9.52 (3/8)	9.52 (3/8)	9.52 (3/8)	9.52 (3/8)
15.88 (5/8)	15.88 (5/8)	15.88 (5/8)	15.88 (5/8)	19.05 (3/4)
25.4/19.4	25.4/19.4	25.4/19.4	25.4/19.4	25.4/19.4
25~100	40~100	50~100	50~100	60~100



ABUQ24GGLA0	ABUQ36GGLA0	ABUQ42GRLA0	ABUQ48GRLA0	ABUQ54GRLA0
7.0	10.0	12.5	13.4	15.8
2.17	3.31	3.88	4.43	5.23
Twin Rotary	Twin Rotary	Twin Rotary	Twin Rotary	Twin Rotary
58	58	70	70	140
48	48	52	52	55
870*655*320	950*834*330	950*834*330	950*834*330	950*1380*330
1022*716*437	1040*918*461	1040*918*461	1040*918*461	1040*1462*461
44	65	67	67	96
48.1	71.8	73.8	73.8	107.1
R410A	R410A	R410A	R410A	R410A
1100	1900	2400	2400	3300
40	40	40	40	40
-15~48	-15~48	-15~48	-15~48	-15~48
1 / 220-240 / 50/60	1 / 220-240 / 50/60	1 / 220-240 / 50/60	1 / 220-240 / 50/60	1 / 220-240 / 50/60
3*2.5	3*2.5	3*5.0	3*5.0	3*5.0
4*0.75	4*0.75	4*0.75	4*0.75	4*0.75
25	30	40	40	40
5	5	5	5	5
50	50	50	50	50
30	30	30	30	30
9.52 (3/8)	9.52 (3/8)	9.52 (3/8)	9.52 (3/8)	9.52 (3/8)
15.88 (5/8)	15.88 (5/8)	15.88 (5/8)	15.88 (5/8)	19.05 (3/4)

Note : 1. Capacities are based on the following conditions Cooling : Indoor Temperature 27°C DB / 19°C WB / Outdoor Temperature 35°C DB / 24°C WB
Heating : Indoor Temperature 20°C DB / 15°C WB / Outdoor Temperature 7°C DB / 6°C WB

2. Annual energy consumption based on average use of 500 running hours per year at Ratedinal condition

* Due to our policy of innovation some specifications may be changed without notification.

Ceiling Suspended



Indoor Unit Model			AVNQ18GJLA0	AVNQ21GJLA0
Capacity	Min	kW		
	Rated	kW	5.0	5.8
	Max	kW		
Running Current (Set)	Rated	A	6.7	8.7
Power Supply		V/Hz	1 / 220-240 / 50/60	1 / 220-240 / 50/60
EER			3.23	3.02
Air Flow Rate	Low	m ³ /min	10.4	11.9
	Medium	m ³ /min	11.4	12.9
	High	m ³ /min	12.4	13.9
Sound Pressure	Low	dBA	41	41
	Medium	dBA	43	43
	High	dBA	44	44
Dimension	Body	W*H*D	mm	950*650*220
	Packing	W*H*D	mm	1052*316*747
Net weight	Net	kg	23.0	23.0
	Gross	kg	28.4	28.4
Piping connection	Liquid	mm(inch)	6.35 (1/4)	6.35 (1/4)
	Gas	mm(inch)	12.7 (1/2)	12.7 (1/2)
	Drain	O.D/I.D	mm	21.5 / 16.0



Outdoor Unit Model			AVUQ18GJLA0	AVUQ21GJLA0	
Capacity	Cooling	Min	kW		
		Rated	kW	5.0	6.0
		Max	kW		
Power Input		Rated	kW	1.55	1.92
Compressor	Type		Twin Rotary	Twin Rotary	
Airflow Rate			m ³ /min	50	50
Sound Pressure	Cooling		dBA	47	47
Dimensions	Body	W*H*D	mm	770*545*288	770*545*288
	Packing	W*H*D	mm	920*585*388	920*585*388
Net weight	Net	kg	36	36	
	Gross	kg	38.3	38.3	
Refrigerant	Type		R410A	R410A	
	Charge	g	900	900	
Additional Refrigerant charge		g/m	20	40	
Operation Range (outdoor)	Min~Max	DB	-15~48	-15~48	
Power Supply		V/Hz	1 / 220-240 / 50/60	1 / 220-240 / 50/60	
Power Supply Cable		N*mm ²	3*2.5	3*2.5	
Transmission Cable		N*mm ²	4*0.75	4*0.75	
Circuit Breaker		A	20	20	
Piping Length total	Min	m	5	5	
	Max	m	30	30	
Piping elevation difference	IDU-ODU	Max	m	15	
Piping connection	Liquid	mm(inch)	6.35 (1/4)	6.35 (1/4)	
	Gas	mm(inch)	12.7 (1/2)	12.7 (1/2)	

Note : 1. Capacities are based on the following conditions Cooling : Indoor Temperature 27°C DB / 19°C WB / Outdoor Temperature 35°C DB / 24°C WB
Heating : Indoor Temperature 20°C DB / 15°C WB / Outdoor Temperature 7°C DB / 6°C WB

2. Annual energy consumption based on average use of 500 running hours per year at Ratedinal condition

* Due to our policy of innovation some specifications may be changed without notification.



AVNQ24GJLA0	AVNQ36GKLA0	AVNQ42GLLA0	AVNQ48GLLA0	AVNQ54GLLA0
7.0	10.0	12.5	13.4	15.8
10.1	14.4	16.9	19.3	22.7
1 / 220-240 / 50/60	1 / 220-240 / 50/60	1 / 220-240 / 50/60	1 / 220-240 / 50/60	1 / 220-240 / 50/60
3.02	3.02	3.22	3.02	3.02
11.9	18.2	25.2	26.6	28.0
12.9	19.8	26.9	28.3	29.7
13.9	21.4	28.6	30.0	31.5
41	41	44	44	45
43	43	46	46	47
44	45	47	47	48
950*650*220	1350*650*220	1750*650*220	1750*650*220	1750*650*220
1052*316*747	1452*316*747	1852*316*747	1852*316*747	1852*316*747
23.0	34.1	42.5	42.5	42.5
28.4	41	51.4	51.4	51.4
9.52 (3/8)	9.52 (3/8)	9.52 (3/8)	9.52 (3/8)	9.52 (3/8)
15.88 (5/8)	15.88 (5/8)	15.88 (5/8)	15.88 (5/8)	19.05 (3/4)
21.5 / 16.0	21.5 / 16.0	21.5 / 16.0	21.5 / 16.0	21.5 / 16.0



AVUQ24GJLA0	AVUQ36GKLA0	AVUQ42GLLA0	AVUQ48GLLA0	AVUQ54GLLA0
7.0	10.0	12.5	13.4	15.8
2.32	3.31	3.88	4.44	5.23
Twin Rotary	Twin Rotary	Twin Rotary	Twin Rotary	Twin Rotary
58	58	70	70	140
48	48	52	52	55
870*655*320	950*834*330	950*834*330	950*834*330	950*1380*330
1022*716*437	1040*918*461	1040*918*461	1040*918*461	1040*1462*461
44	65	67	67	96
48.1	71.8	73.8	73.8	107.1
R410A	R410A	R410A	R410A	R410A
1100	1900	2400	2400	3300
40	40	40	40	40
-15~48	-15~48	-15~48	-15~48	-15~48
1 / 220-240 / 50/60	1 / 220-240 / 50/60	1 / 220-240 / 50/60	1 / 220-240 / 50/60	1 / 220-240 / 50/60
3*2.5	3*2.5	3*5.0	3*5.0	3*5.0
4*0.75	4*0.75	4*0.75	4*0.75	4*0.75
25	30	40	40	40
5	5	5	5	5
50	50	50	50	50
30	30	30	30	30
9.52 (3/8)	9.52 (3/8)	9.52 (3/8)	9.52 (3/8)	9.52 (3/8)
15.88 (5/8)	15.88 (5/8)	15.88 (5/8)	15.88 (5/8)	19.05 (3/4)

Note : 1. Capacities are based on the following conditions Cooling : Indoor Temperature 27°C DB / 19°C WB / Outdoor Temperature 35°C DB / 24°C WB
Heating : Indoor Temperature 20°C DB / 15°C WB / Outdoor Temperature 7°C DB / 6°C WB

2. Annual energy consumption based on average use of 500 running hours per year at Ratedinal condition

* Due to our policy of innovation some specifications may be changed without notification.

Ceiling Cconcealed Duct (Low Static)



Indoor Unit Model Name			ABNQ18GL2A0	ABNQ21GL2A0	ABNQ24GL3A0	
Capacity	Min	kW				
	Rated	kW	5.0	5.8	7.0	
	Max	kW				
Running Current (Set)	Rated	A	6.7	8.7	10.1	
Power Supply		∅V/Hz	1 / 220-240 / 50/60	1 / 220-240 / 50/60	1 / 220-240 / 50/60	
EER			3.23	3.02	3.02	
Air Flow Rate	Low	m ³ /min	10.0	10.0	12.0	
	Medium	m ³ /min	12.5	12.5	16.0	
	High	m ³ /min	15.0	15.0	20.0	
Sound Pressure	Low	dBA	31	31	32	
	Medium	dBA	34	34	35	
	High	dBA	36	36	39	
Dimmension	Body	W*H*D	mm	900*190*700	900*190*700	1100*190*700
	Packing	W*H*D	mm	1060*248*775	1060*248*775	1260*248*775
Net weight	Net		kg	22.0	22.0	27.0
	Gross		kg	26.0	26.0	32.0
Piping connection	Liquid		mm(inch)	6.35 (1/4)	9.52 (3/8)	9.52 (3/8)
	Gas		mm(inch)	12.7 (1/2)	15.88 (5/8)	15.88 (5/8)
	Drain	O.D/I.D	mm	25.4 / 20.4	25.4 / 20.4	25.4 / 20.4
External Static Pressure	Min~Max	Pa	0~50	0~50	0~50	



Outdoor Unit Model Name			ABUQ18GL2A0	ABUQ21GL2A0	ABUQ24GL3A0	
Capacity	Min	kW				
	Rated	kW	5.0	6.0	7.0	
	Max	kW				
Power Input	Rated	kW	1.55	1.92	2.32	
Compressor	Type		Twin Rotary	Twin Rotary	Twin Rotary	
Airflow Rate		m ³ /min	50	50	58	
Sound Pressure	Cooling		dBA	47	47	48
Dimmensions	Body	W*H*D	mm	770*545*288	770*545*288	870*655*320
	Packing	W*H*D	mm	920*585*388	920*585*388	1022*716*437
Net weight	Net		kg	36	36	44
	Gross		kg	38.3	38.3	48.1
Refrigerant	Type			R410A	R410A	R410A
	Charge		g	900	900	1100
Additional Refrigerant charge			g/m	20	40	40
Operation Range (outdoor)	Min~Max		∅DB	-15~48	-15~48	-15~48
Power Supply			∅V/Hz	1 / 220-240 / 50/60	1 / 220-240 / 50/60	1 / 220-240 / 50/60
Power Supply Cable			N*mm ²	3*2.5	3*2.5	3*2.5
Transmission Cable			N*mm ²	4*0.75	4*0.75	4*0.75
Circuit Breaker			A	20	20	25
Piping Length total	Min		m	5	5	5
	Max		m	30	30	50
Piping elevation difference	IDU-ODU	Max	m	15	15	30
Piping connection	Liquid		mm(inch)	6.35 (1/4)	6.35 (1/4)	9.52 (3/8)
	Gas		mm(inch)	12.7 (1/2)	12.7 (1/2)	15.88 (5/8)

Note : 1. Capacities are based on the following conditions Cooling : Indoor Temperature 27°C DB / 19°C WB / Outdoor Temperature 35°C DB / 24°C WB
Heating : Indoor Temperature 20°C DB / 15°C WB / Outdoor Temperature 7°C DB / 6°C WB

2. Annual energy consumption based on average use of 500 running hours per year at Ratedinal condition

* Due to our policy of innovation some specifications may be changed without notification.