

A close-up photograph of several ears of corn on the cob, partially husked, resting on a dark metal grill. A pair of silver metal tongs is positioned over one of the ears. The background is dark and out of focus.

# APPLIANCES FOR LIVING

**BUILT-IN BARBECUE FOR HOME  
OUTDOOR & INDOOR USE  
OPERATION MANUAL**

 **ARTUSI**  
THE ART OF LIVING

**MODELS**  
ABBQ1B, ABBQ2B, ABBQ3B, ABBQ1MB, ABBQ2MB,  
ABBQ3MB, ABBQM, ABBQM2, ABBQM3

## WELCOME TO THE ART OF LIVING

Congratulations, you are now the proud owner of an ARTUSI cooking appliance. Thank you for purchasing ARTUSI and welcome to the ARTUSI Family.

This instruction manual has been specially created to inform you of the full range of features your ARTUSI appliance has to offer and serves as an introduction to getting the very best out of your ARTUSI appliance.

We present detailed information on each of the features your ARTUSI appliance consists of. Once you have read this section you will be able to choose the most appropriate settings for your appliance when cooking different types of food.

**KEEP THE DOCUMENTATION OF THIS PRODUCT FOR FUTURE REFERENCE.**

**REGISTER YOUR WARRANTY ONLINE NOW AT [WWW.EUROLINX.SUPPORT](http://WWW.EUROLINX.SUPPORT)**

**Note:** This user manual is prepared for more than one model.  
Some of the features specified in this Manual may not be available on your appliance.

All our appliances are only for domestic use, not for commercial use.  
Products marked with (\*) are optional.

**“THIS APPLIANCE SHALL BE INSTALLED IN ACCORDANCE WITH THE REGULATIONS FORCE AND ONLY USED IN A WELL VENTILATED SPACE. READ THE INSTRUCTIONS BEFORE INSTALLING OR USING THIS APPLIANCE”**



**TO REGISTER  
YOUR WARRANTY**



THIS APPLIANCE IS CONCEIVED FOR DOMESTIC USE ONLY. THE MANUFACTURER SHALL NOT IN ANY WAY BE HELD RESPONSIBLE FOR WHATEVER INJURIES OR DAMAGES ARE CAUSED BY INCORRECT INSTALLATION OR BY UNSUITABLE, WRONG OR ABSURD USE.



THIS APPLIANCE IS NOT INTENDED FOR USE BY PERSONS (INCLUDING CHILDREN) WITH REDUCED PHYSICAL, SENSORY OR MENTAL CAPABILITIES, OR LACK OF EXPERIENCE AND KNOWLEDGE UNLESS THEY HAVE BEEN GIVEN , SUPERVISION OR INSTRUCTION CONCERNING USE OF THE APPLIANCE BY A PERSON RESPONSIBLE FOR THEIR SAFETY . CHILDREN SHOULD BE SUPERVISED TO ENSURE THAT THEY DO NOT PLAY WITH THE APPLIANCE .

If the supply cord is damaged, it must be replaced by the manufacturer or its service agent or a similarly qualified person in order to avoid a hazard.

WHERE THIS APPLIANCE IS INSTALLED IN MARINE CRAFT OR IN CARAVANS, IT SHALL NOT BE USED AS A SPACE HEATER. DO NOT SPRAY AEROSOLS IN THE VICINITY OF THIS APPLIANCE WHILE IT IS IN OPERATION. DO NOT USE OR STORE FLAMMABLE MATERIALS NEAR THIS APPLIANCE. DO NOT MODIFY THIS APPLIANCE.

# CONTENTS

Product description	5
Components	7
Important safety instructions	9
Assembling the barbecue	12
Gas Connection	17
Installation Procedure	19
Gas cylinder safety information	22
Installation instructions	27
Application of the thin cover or cooking hood	36
Usage instructions	38
Igniting the BBQ	40
Cleaning and care	42
Maintenance	44
Troubleshooting	45
Warranty	47

# IMPORTANT

This **Artusi BBQ** is certified for both outdoor and indoor installation under certificates # GAS-105435-005 (outdoor certification to ASNZS5263.1.7-2016) and GAS-105435-004 (indoor certification to ASNZS5263.1.1-2020 ) issued by Global-Mark. Some differences exist re-installation requirements for indoor and outdoor use:

1. Indoor installation requires a 1200mm clearance between BBQ and rangehood whereas outdoor installation requires 600mm
2. Indoor installation does not require an interlock
3. Indoor installation is not approved for use with cooking hood
4. Indoor installation is not approved with internal gas bottle

## PRODUCT DESCRIPTION

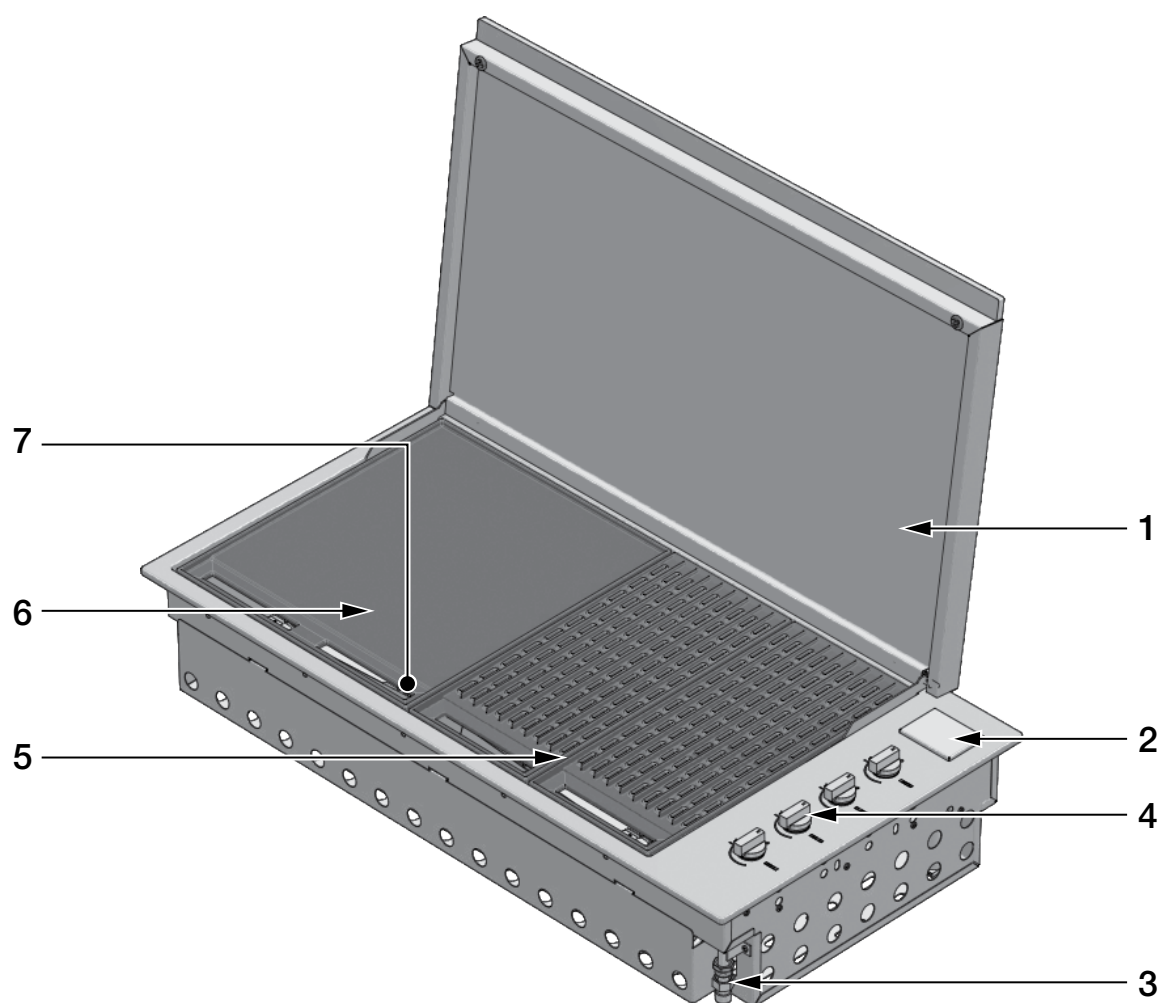

### INTEGRATED BARBECUE WITH THIN COVER

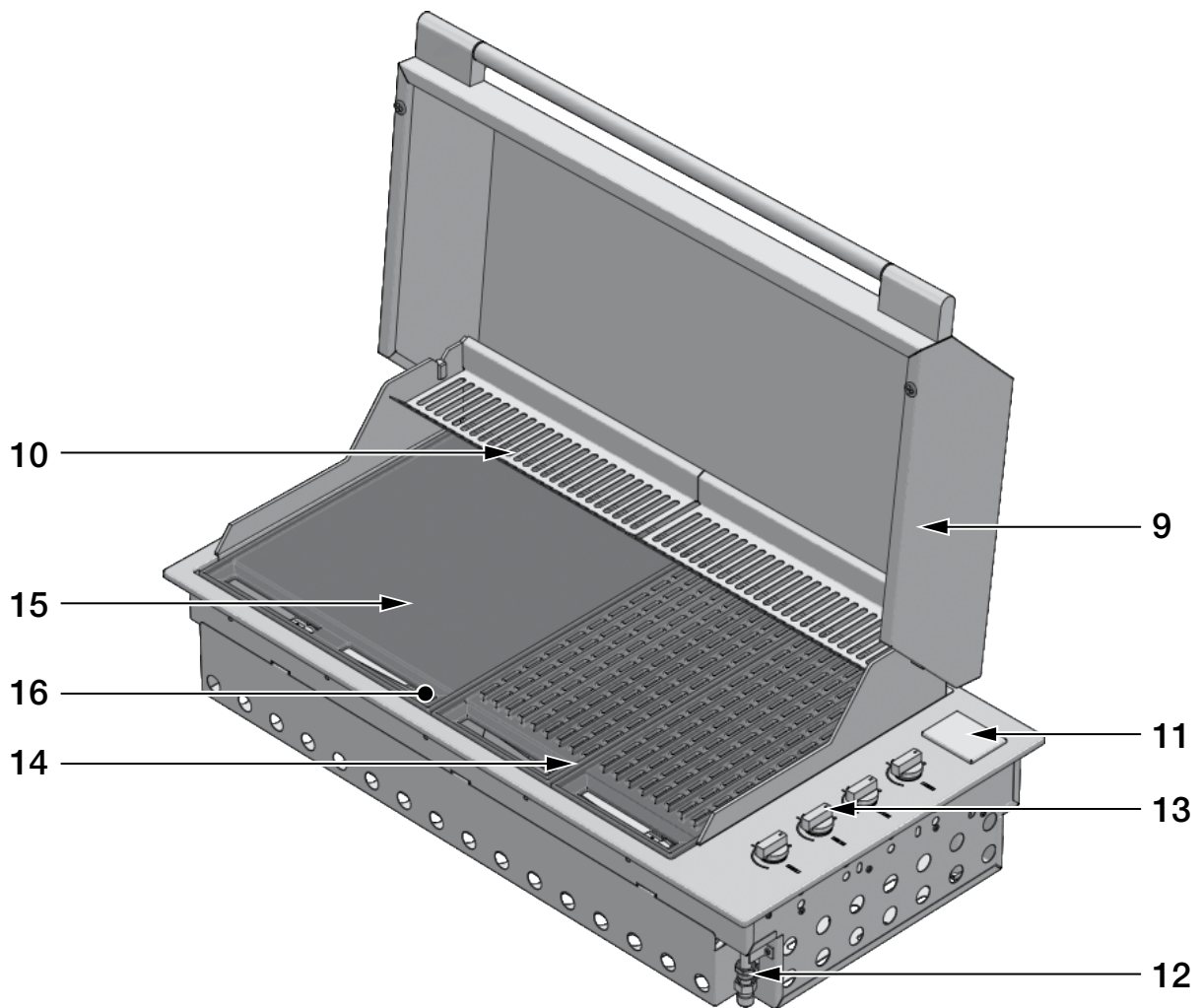

1. Thin cover (Suitable for indoor and outdoor use)
2. Battery compartment cover
3. Gas connection point
4. Burner controls
5. Grill groups (2 sets)
6. Cooking plate
7. Removable oil collection drip plan located in front of the barbecue (not shown)
8. Flame diffusers (2 pcs.) located under the grills (not shown)



### **INTEGRATED BARBECUE HIGH COVER**

- 9. High cover (Outdoor use only)
- 10. Heating racks
- 11. Battery compartment cover
- 12. Gas connection point
- 13. Burner controls
- 14. Grill group
- 15. Cooking plate
- 16. Removable oil collection drip pan located in front of the cooking surface (not shown)
- 17. Flame diffusers (2 pcs.) located under the grills (not shown)

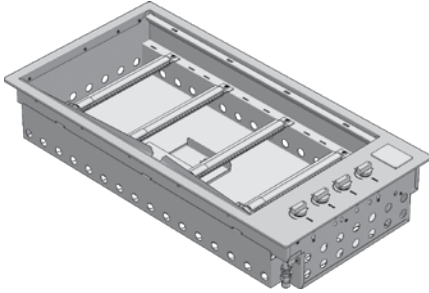
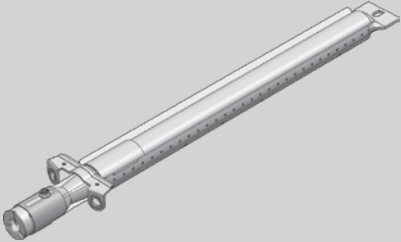
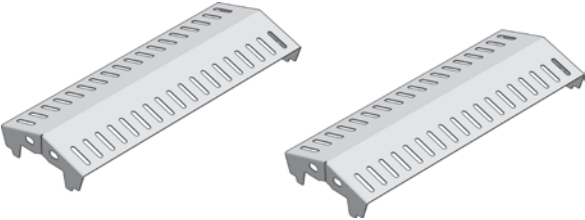
# COMPONENTS

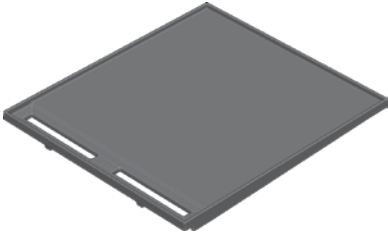
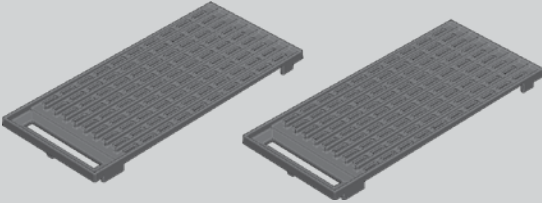
	DESCRIPTION	QTY
	Burner box and external profile	1
	Burners	2 for 60cm model 3 for 80cm model 4 for 100cm model
	Flame diffusers	2 for 60cm model 3 for 80cm model 4 for 100cm model
	Oil tray	1
	Solid cooking plate only for 80 and 100cm models.	1
	Grill groups	2 for 60cm model 3 for 80cm model 4 for 100cm model



Universal LPG regulator and hose  
**(OUTDOOR USE ONLY)**

1



Natural gas regulator and braided  
hose if required  
**(INDOOR OR OUTDOOR USE)**

**HOSE NOT  
SUPPLIED**

**CONFIGURATION 1**

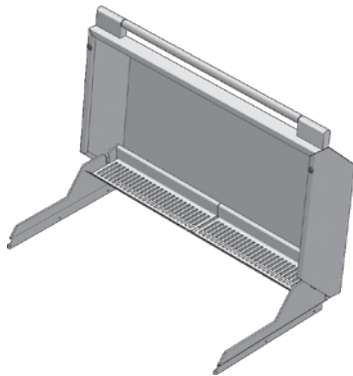

High cover for cooking  
**(OUTDOOR USE ONLY)**

1

**CONFIGURATION 2**

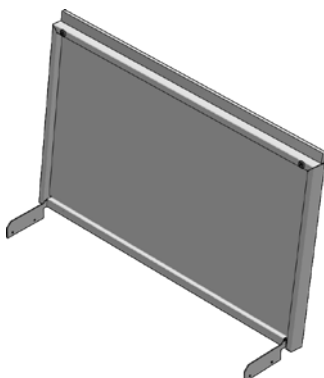

Low cover  
**(INDOOR OR OUTDOOR USE)**

1



# IMPORTANT SAFETY INSTRUCTIONS

**FOR YOUR OWN SAFETY, YOU SHOULD READ THIS MANUAL BEFORE OPERATING THE BARBECUE.**

## USE

Carefully read the user manual and keep it in a handy place for future reference.  
Below, we explain the meaning of the symbols used in this manual:



### ATTENTION

This symbol indicates information relating to the user's personal safety



### WARNING

This symbol indicates information on how to prevent damage to the appliance



### TIPS AND INFORMATION

This symbol indicates tips and information about the use of the appliance



### SUGGESTION FOR THE ENVIRONMENT

This symbol indicates information for the economical and ecological use of the appliance



This symbol indicates a prohibited action



### ATTENTION

The appliance **MUST** only be installed and serviced by qualified and authorized personnel.  
Improper installation, modification, adjustment or maintenance can cause personal injury or property damage.  
Contact your nearest Service Centre for further information.

## NOTE FOR THE INSTALLER:

**THIS MANUAL MUST BE LEFT WITH THE OWNER FOR FUTURE REFERENCE**

Only use a licensed gas fitter to install this barbecue and other trades as applicable; electrician, carpenter, bricklayer.

-  Do not lean over barbecue while lighting.
-  Do not leave the barbecue unattended when it is on.
-  Do not delay ignition once the gas is opened.
-  Do not store or use aerosol sprays near the barbecue.
-  Do not store inflammable liquids near the barbecue.
-  Do not use abrasive or caustic detergents on the barbecue.
-  Do not operate the barbecue with the cover closed.
-  Do not attempt to disassemble or adjust the control valves.
-  Do not attempt to disassemble or adjust the cylinder regulator (not supplied) but, if necessary, replace with a new one.
-  Do not use an open flame to check for leaks.
-  Do not modify the structure of the appliance and do not modify the dimensions of the injector orifice.
-  Do not obstruct the ventilation openings of the barbecue.
-  Do not allow children to operate the barbecue or play near it.
-  Keep any electrical wires and fuel hoses away from hot surfaces.
-  Never store a spare gas cylinder near the barbecue.
-  Do not use or store flammable materials near this appliance.
-  Do not spray aerosols in the vicinity of this appliance while it is in operation.
-  Do not use this appliance as a space heater.
-  Do not modify this appliance.
-  Do not place articles on or against this appliance.
-  This appliance reaches high temperatures. Be especially careful when children and elderly persons are present
-  Keep children under the age of eight years away, if not constantly supervised.
-  Never attempt to extinguish a flame/fire with water: turn off the appliance and cover the flame with a cover or a fire blanket.
-  Be careful when handling gas cylinders even if they appear empty, in compliance with current safety rules.  
(For LPG installation only)

 Do not use dented or rusty gas cylinders. (For LPG installation only)

 Do not disconnect the gas cylinder from the appliance when it is on. Perform any service on the gas cylinder far away from the appliance. (For LPG installation only)

 Only turn the burners on with the cover lifted

 If the knob becomes difficult to rotate, have the taps checked by an authorized service centre.

 Lower the cover, accompanying it with your hand and make sure that nothing is obstructing its proper closure.

 When cooking with the cover closed keep an eye on the thermometer: if the temperature exceeds 350 °C, lift the cover to prevent dangerous overheating. (Applies to models with hooded lid - Outdoor use only)

 Do not leave objects on the cooking surfaces.

 Never use the appliance to heat the area.

 Always close the inlet connection / manual shut off valve after use (for Natural Gas connections) or always close the valve of the gas cylinder after use. (For LPG connections)

#### **THE MANUFACTURER'S LIABILITY:**

The manufacturer will not be liable for personal injury or property damage caused by:

- any use of the appliance other than anticipated;
- failure to follow the instructions of the user manual;
- tampering with any part of the appliance;
- use of other than original parts.

# ASSEMBLING THE BARBECUE

## TOOLS NEEDED FOR ASSEMBLY:

- Phillips screwdriver

1. Remove all components from the box.

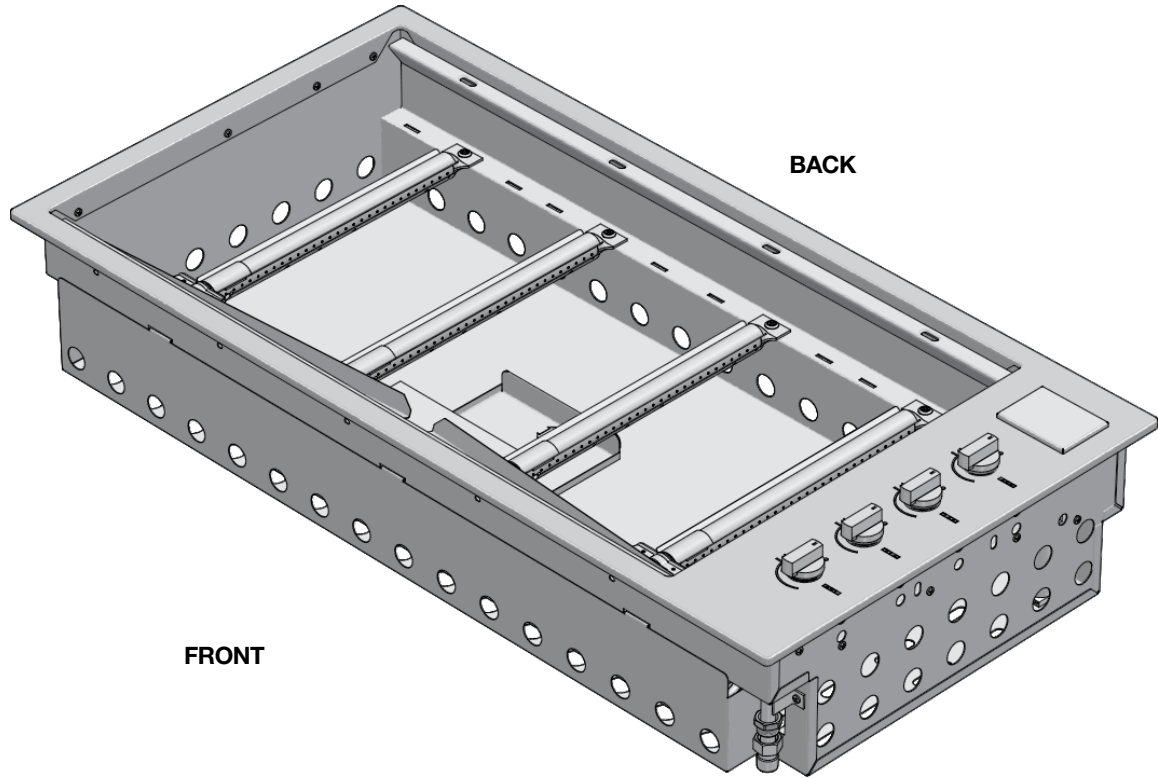

2. Place the flame diffusers in the desired positions (under the points (A) in which the grill sections will be placed) and attach the rear edge of the flame diffuser to the rear of the body of the barbecue.

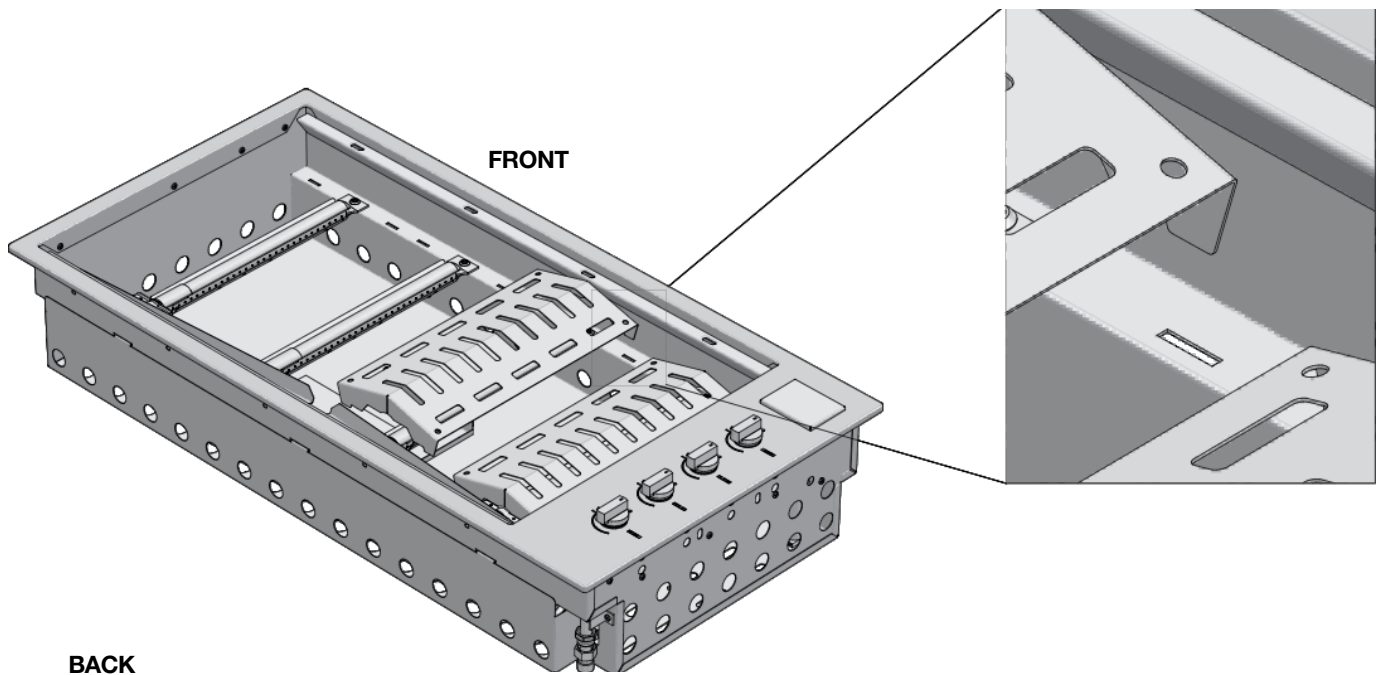

3. Apply the oil drip pans to the front of the barbecue.

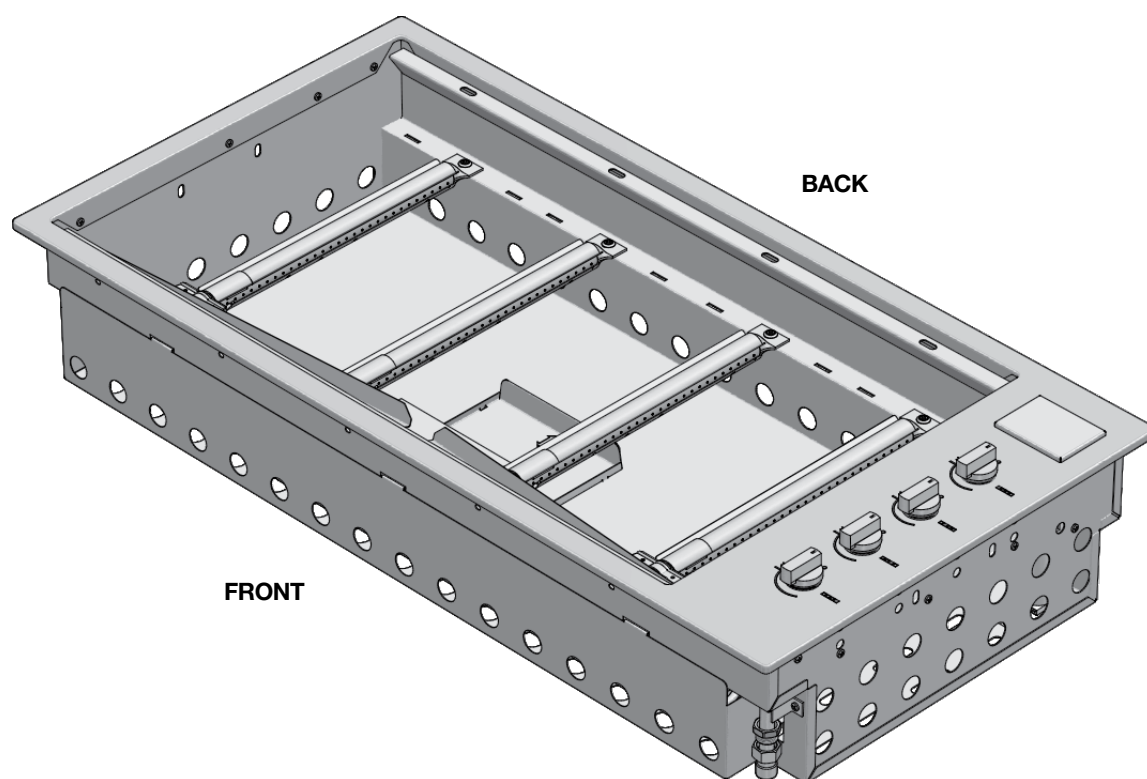
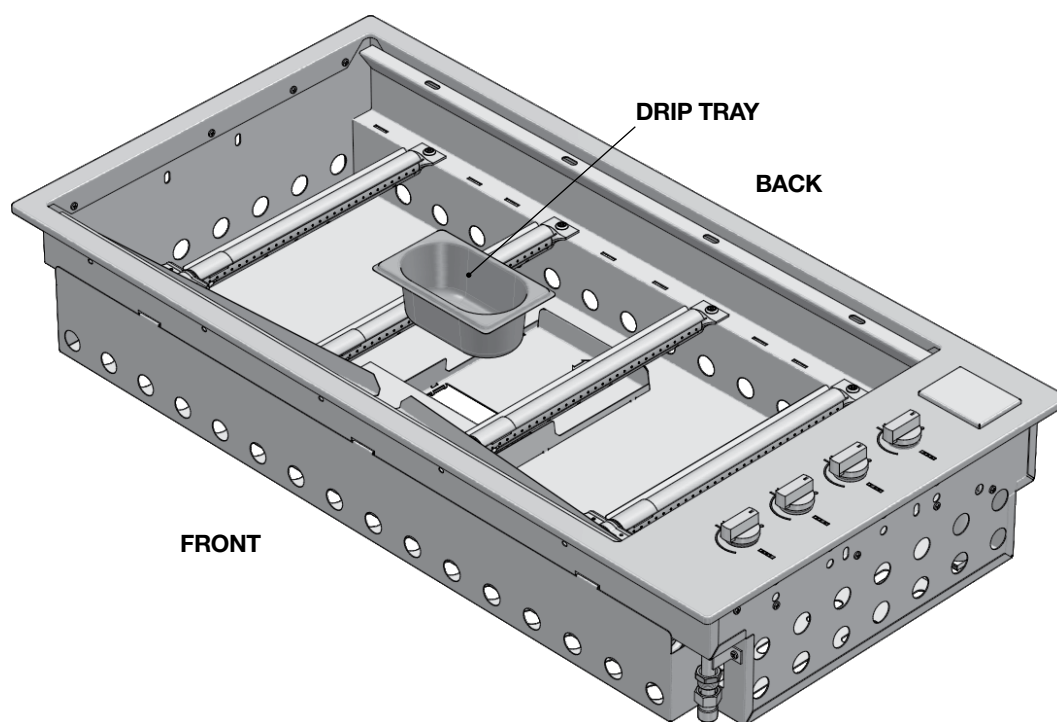

4. Place the cooking plate and grill sections in the desired positions, making sure that the flame diffusers are under the grill sections.

NOTE: Make sure that the grill groups are correctly oriented so that the surface of the grill is tilted forward to allow the oil to drain into the drip pan.

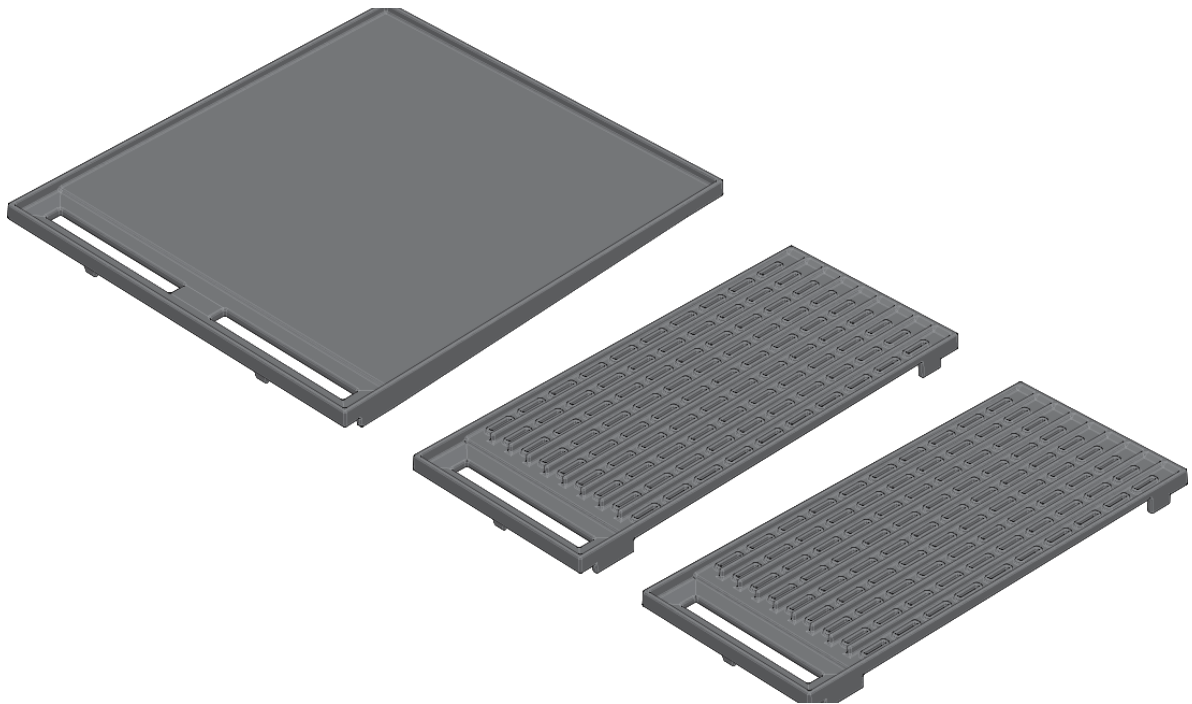

5. After installation in the counter, connect the thin cover or cooking hood area as described in the chapter “Application of the thin cover or cooking hood” in this manual.

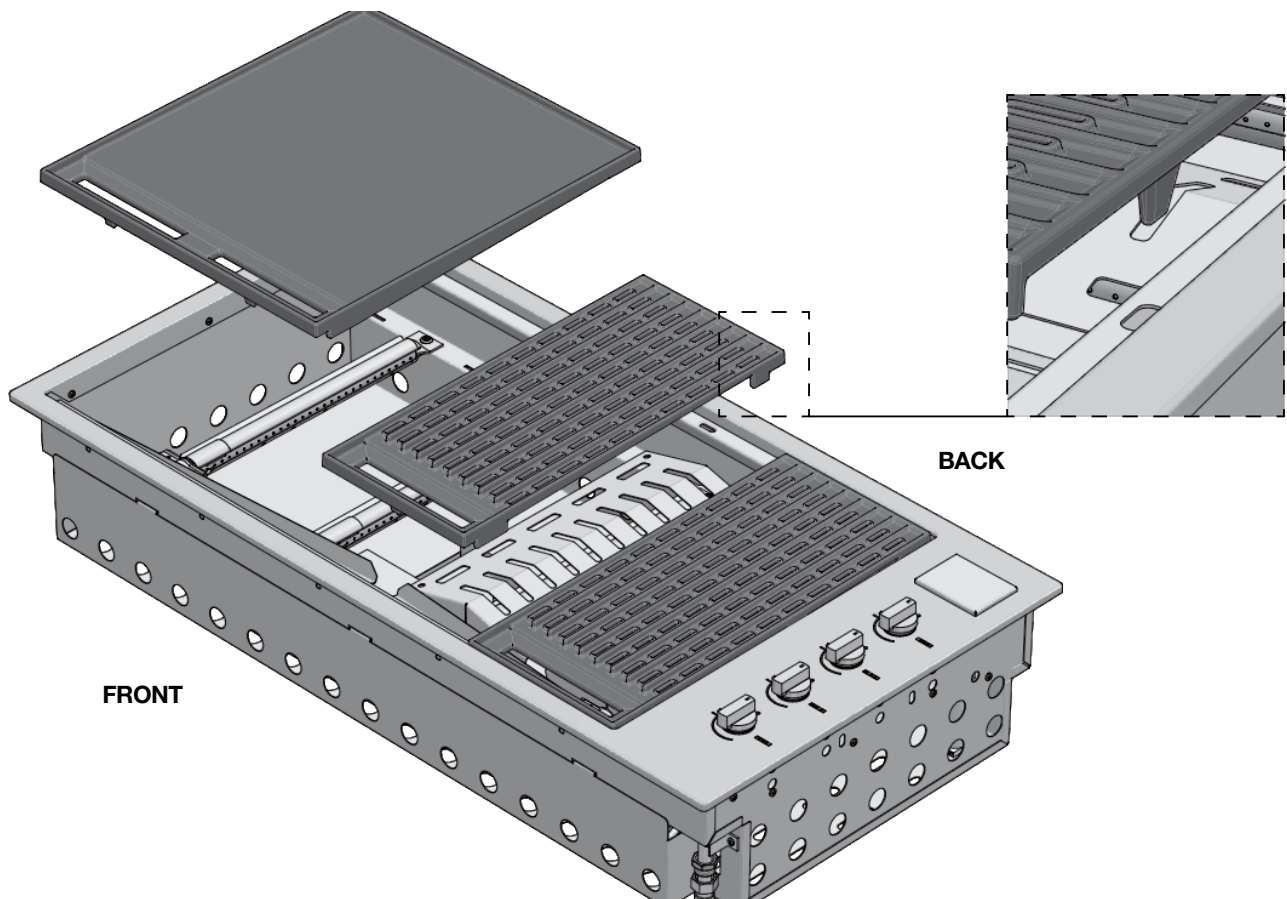

<b>GAS TYPE (Applies to all models)</b>	<b>NATURAL GAS</b>	<b>UNIVERSAL LPG</b>
Nominal heat input (MJ/h) / Per Burner	13	13
Injector diameter (1/100mm)	170	100
Number of injectors	1	1
Pressure (kPa)	1	2,75
Primary air regulation (mm)	20mm	20mm

**Adapting to different types of gas. Conversion to another gas type must be carried out by a authorised by a person.**

If the appliance is configured for a different type of gas than that available, you have to replace the injectors with ones corresponding to the type of gas to be used (see table above). The replacement will be made using an adequate 7 mm spanner after having lowered the burners as in the following images. After replacing the injector, regulate the air to 20mm for natural gas and to 20mm for LPG.

To adjust the minimum, after lighting the burner, remove the knob and the gasket below and rotate the screw of the tap (B - see page 21), which should be totally closed for LPG and opened about 3/4 turn for natural gas, keeping in mind that a flame lower than 3 mm may not even be "perceived" by the thermocouple of the tap. After regulating the minimums, replace the gaskets and knobs.

1 - Unscrew the fixing screws of the burner.

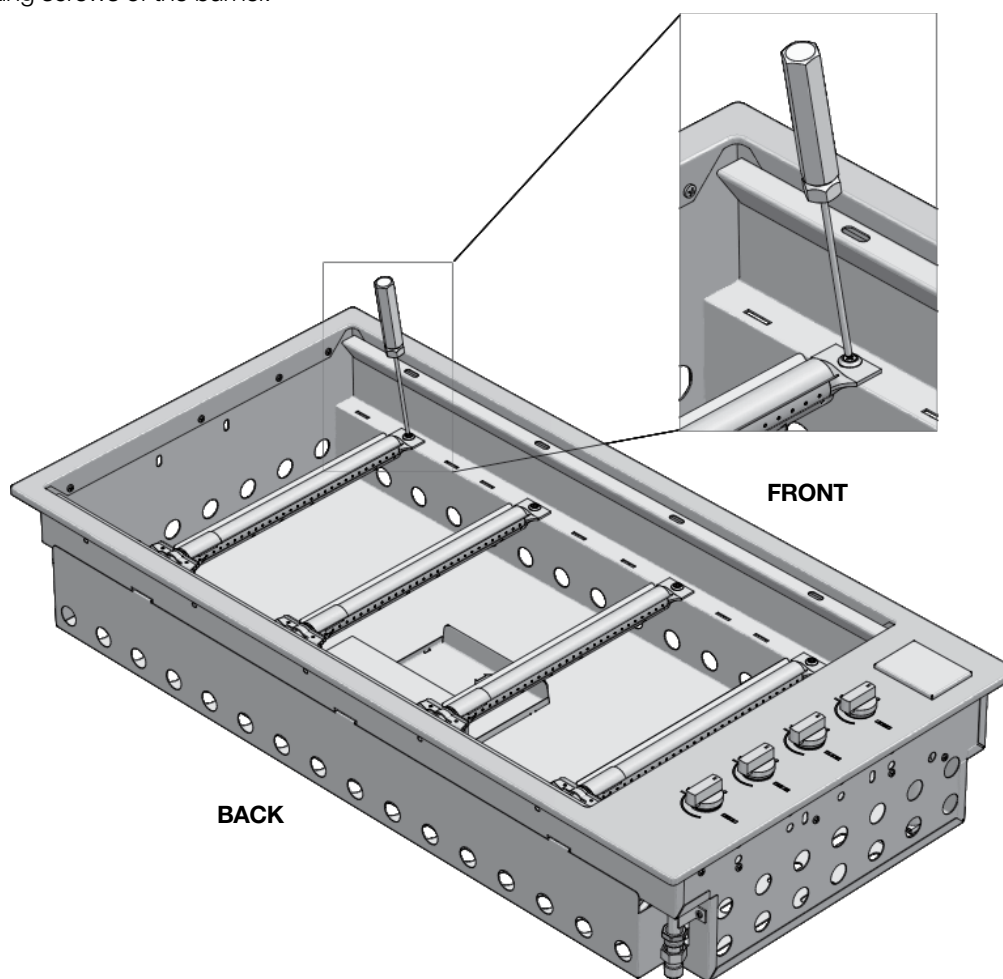

2 - Lower the burner and replace the injector.

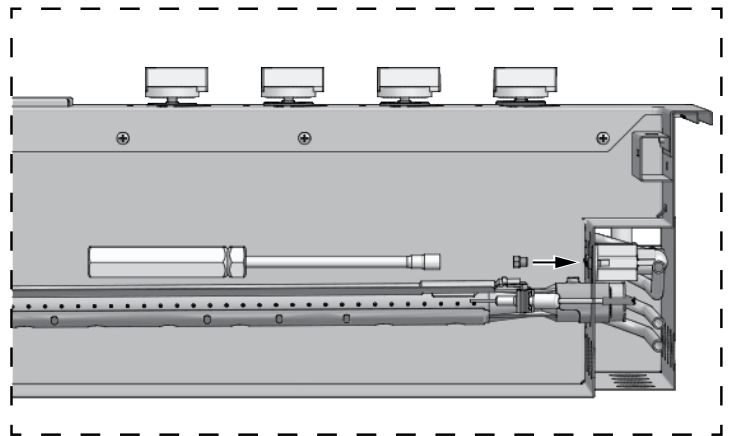
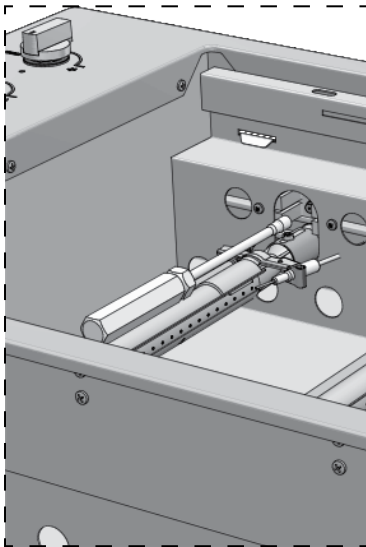
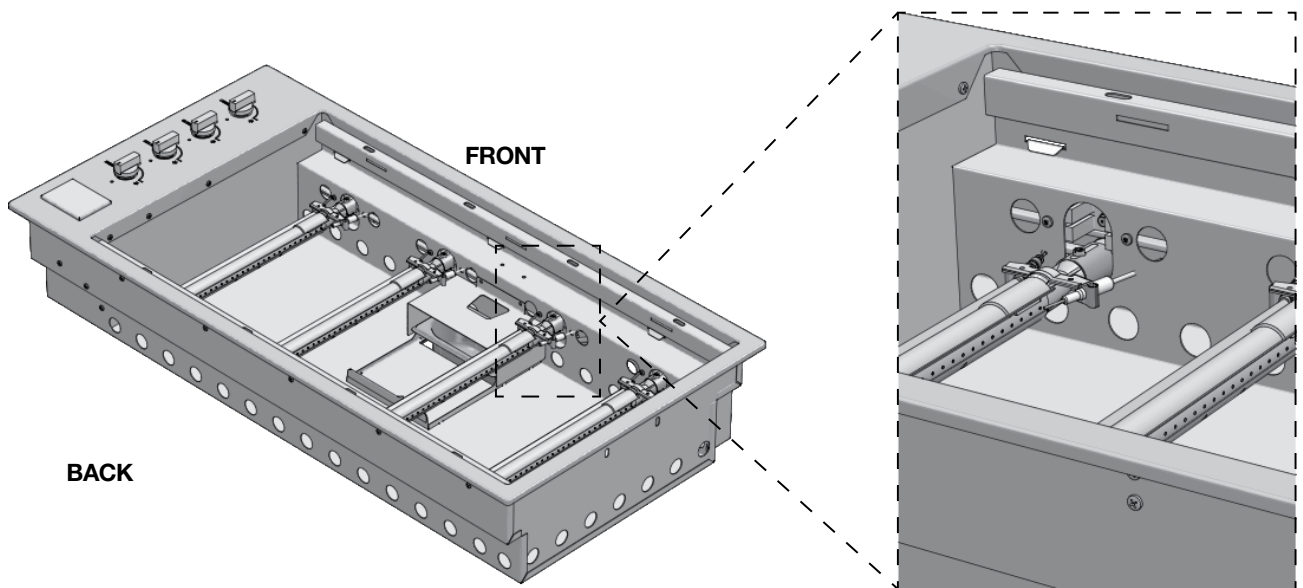

**FRONT**

**NOTES**

- The appliance **MUST** only be installed and serviced by qualified and authorised personnel.
- The product is designed for indoor or outdoor use.  
PLEASE FOLLOW THIS MANUAL DEPENDING ON YOUR INSTALLATION PREFERENCE
- The product must be installed according to the instructions, which require ventilation openings to allow the grill to work properly. The lack of adequate ventilation to supply air to the appliance can lead to poor operation of the burners or excessive heat build-up in the installation compartment.



## GAS CONNECTION (OUTDOOR USE ONLY)

- The unit's ventilation openings must not be covered during installation.

### REFER TO AS/NZS 5601 (GAS INSTALLATIONS) AND FOLLOWING PAGE FOR FURTHER DETAILS

Connect the appliance to the cylinder or system according to the requirements of current law, making sure that the appliance is configured for the type of gas available. If not, see: "Adapting to different types of gas". Also check that the feed pressure falls within the values shown in the table: "Gas specifications".

### RIGID AND SEMI-RIGID METAL AND RUBBER HOSE CONNECTIONS MUST BE APPROVED TO AS/NZS 1869 FOR HOSE ASSEMBLIES AND AS 4631 FOR SEMI-RIGID CONNECTORS FOR GAS.

Make the hook-up with metal fittings and pipes (even flexible hoses) so as not to stress the components inside the appliance. A rubber hose connection complies with current law only if the hose can be inspected along its entire length and easily replaced near the expiration indicated on the hose.

**NOTE:** - After installation, use soapy water to check the perfect seal of the entire connection system.

### DO NOT USE AN OPEN FLAME TO CHECK THE GAS SEAL.

- I. For connection to 9Kg portable gas cylinders please refer to page 33
- II. For connection to a fixed LPG Supply: It is possible to connect this barbecue to a fixed LPG reticulated piping system which may supply gas to other appliances in the building. The installation must be carried out by a licenced gas fitter in accordance with AS/NZS 5601 and any relative Building Code/Statutory Regulations. The gas fitter must check the appliance data label to confirm the gas type prior to installation, ensure that the barbecue is operating correctly and show the customer how to operate the barbecue on completion of installation
- III. For connection to a fixed natural gas supply: It is possible to connect this barbecue to a fixed natural gas piping reticulated system. The installation must be carried out by a licenced gas fitter in accordance with this instruction manual, AS/NZS 5601 and any relative Building Codes/Statutory Regulations. The gas fitter must check the appliance data label to confirm the gas type prior to installation, ensure that the barbecue is operating correctly and show the customer how to operate the barbecue on completion of the installation

### IMPORTANT NOTES RELATING TO FIXED INSTALLATION BARBECUES

- For barbecues designed for built in fixed installation: please ensure that the clearances referred to on pages 24, 26, 28 & 35 of this manual are observed and adhered to
- For barbecue designed for built in fixed installation
  - I. Before each use remove any accumulated grease and other cooking residue
  - II. Check the hose & regulators, if they appear to be damaged in any way, have a licenced gas fitter replace them

### IMPORTANT NOTES RELATING TO CONNECTION VIA PORTABLE LPG CYLINDER

- For barbecues connected via 9Kg portable LPG cylinder: Should the cylinder be housed in a closed compartment under the barbecue, minimum free ventilation at high and low level of 20,000mm squared is required as per AS/NZS 5601 Appendix J Clause J3.4 (d) Please refer to pages 32-33 of this manual for assistance
- For barbecues connected via 9Kg portable LPG cylinder: The barbecue is supplied with a hose and regulator already attached to the barbecue manifold
  - I. Attach the regulator end of the hose assembly to the LPG cylinder
  - II. Ensure that the valves on the barbecue are in the off position
  - III. Turn the cylinder valve on and apply a soapy water solution to all of the joints to ensure there are no gas leaks. If bubbles form at any of the joints this indicates a gas leak and the cylinder valve should be turned off and the joints tightened.
  - IV. If the gas leak persists, turn the cylinder valve off and contact an authorised installer/dealer for assistance
  - V. Never look for gas leaks with a naked flame
  - VI. Check the hose & regulator assembly on a regular basis and if found to be damaged, have it replaced. It is recommended that these components be replaced every five years
  - VII. Inspect the gas cylinder routinely to ensure the test date is not overdue. Cylinder should be re-tested and certified every 10 years
  - VIII. Before each use remove any accumulated grease & any other cooking residue

# GAS CONNECTION

## GAS CONNECTION

Connect the appliance to the piping system according to the requirements of current law, making sure that the appliance is configured for the type of gas available. If not, see: "Adapting to different types of gas". Also check that the feed pressure falls within the values shown in the table: "Gas specifications".

## CONNECTION USING HOSE ASSEMBLIES OR SEMI-RIGID CONNECTORS FOR GAS

If installing this appliance with a semi rigid hose assembly connector for gas, the hose assembly must be certified to AS/NZS 1869 Class B or D with a length of no more than 1.2 metres. The semi-rigid connector must be certified to AS 4631. (Ref AS/NZS5601.1 (refer to Clause 6.6.1))

**NOTE: - After installation, use soapy water to check the perfect seal of the entire connection system. DO NOT USE AN OPEN FLAME TO CHECK THE GAS SEAL.**

Refer to AS/NZS 5601.1 for (6.3) GAS APPLIANCE LOCATION, (6.4) AIR SUPPLY TO GAS APPLIANCES & (6.10.1.7) Barbecues in residential premises; minimum vertical clearance to an overhead grease filter or overhead combustible surface is 1200mm.

Maximum height of the top of the grill with respect to the surface that supports the appliance is 10mm.

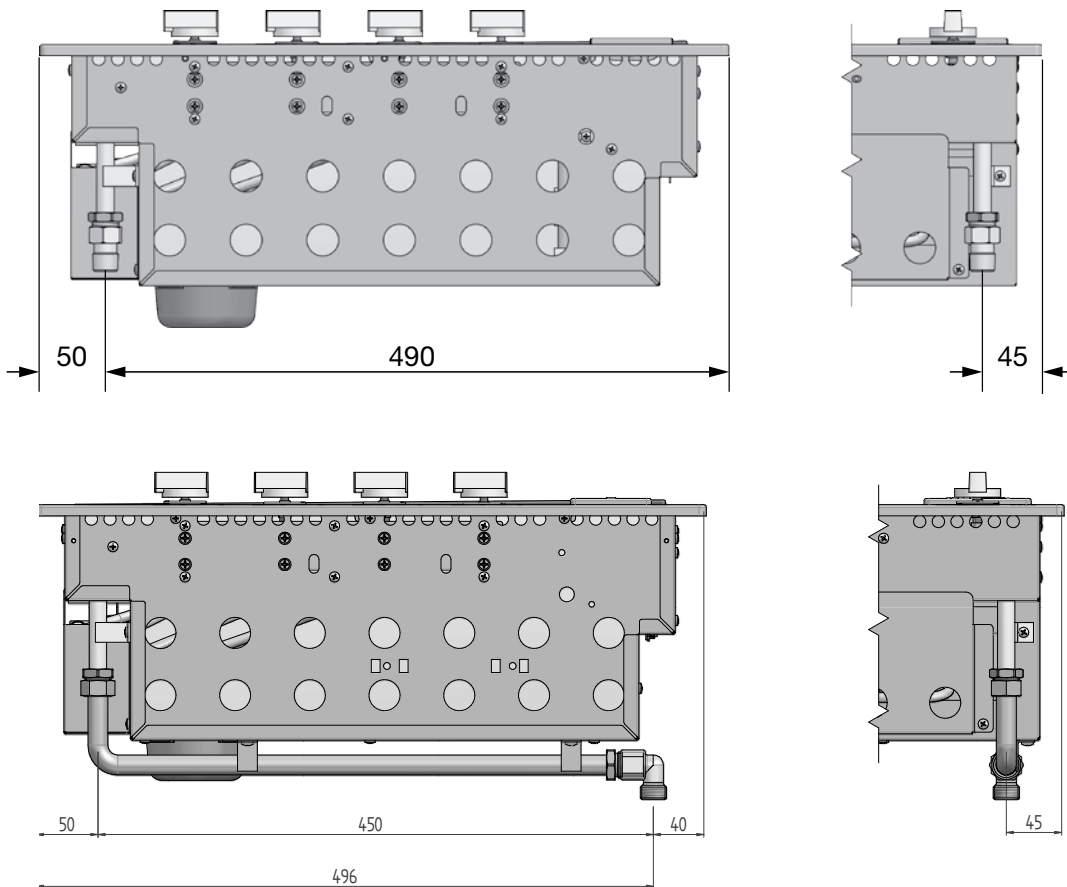

# INSTALLATION PROCEDURE FOR ULPG

AS/NZS 5601

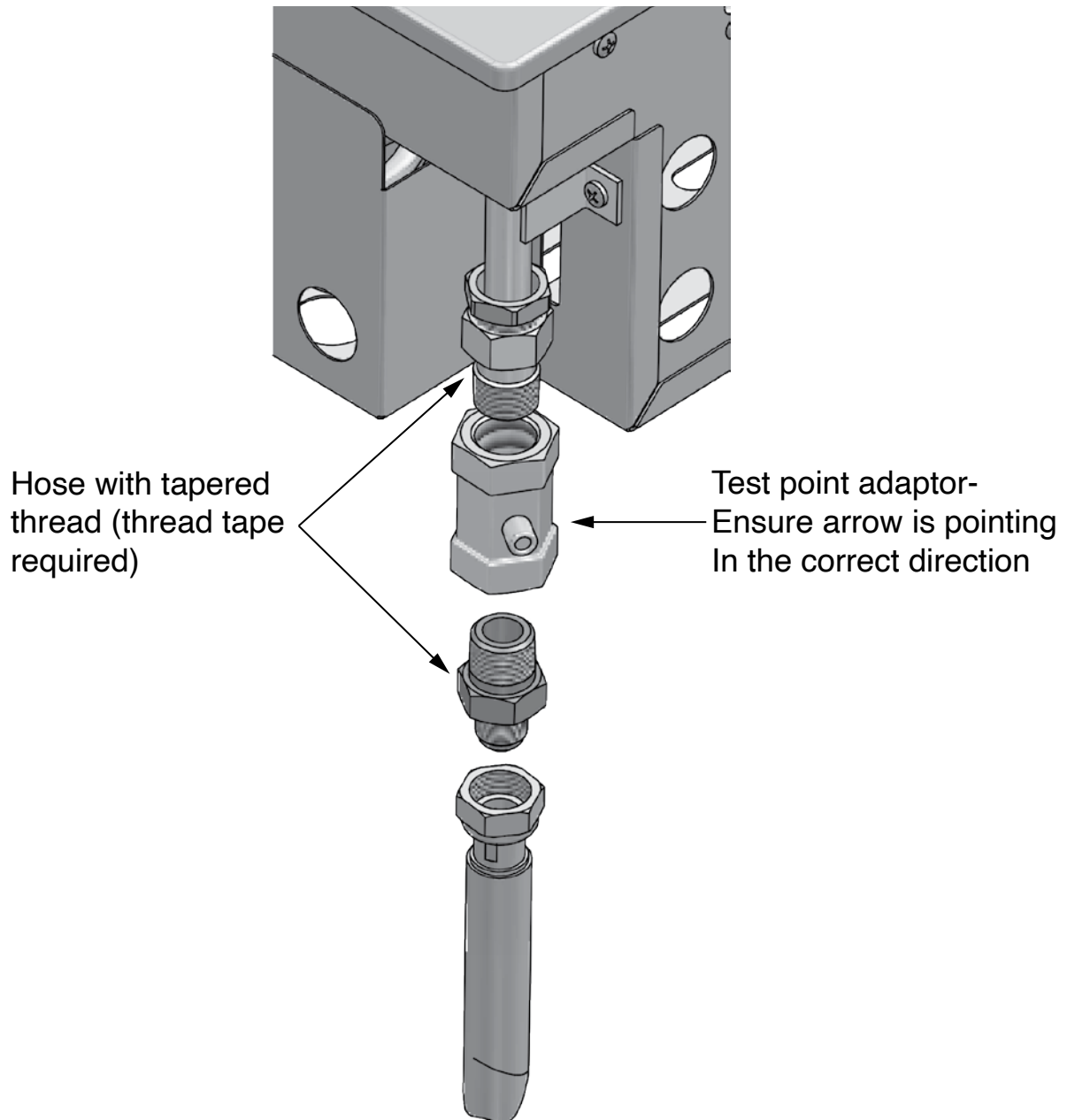

CONVERSION TO ANOTHER GAS TYPE MUST BE CARRIED OUT BY AN AUTHORISED SERVICE TECHNICIAN

**CONVERSION PROCEDURE**

**NORMAL LPG TO NG**

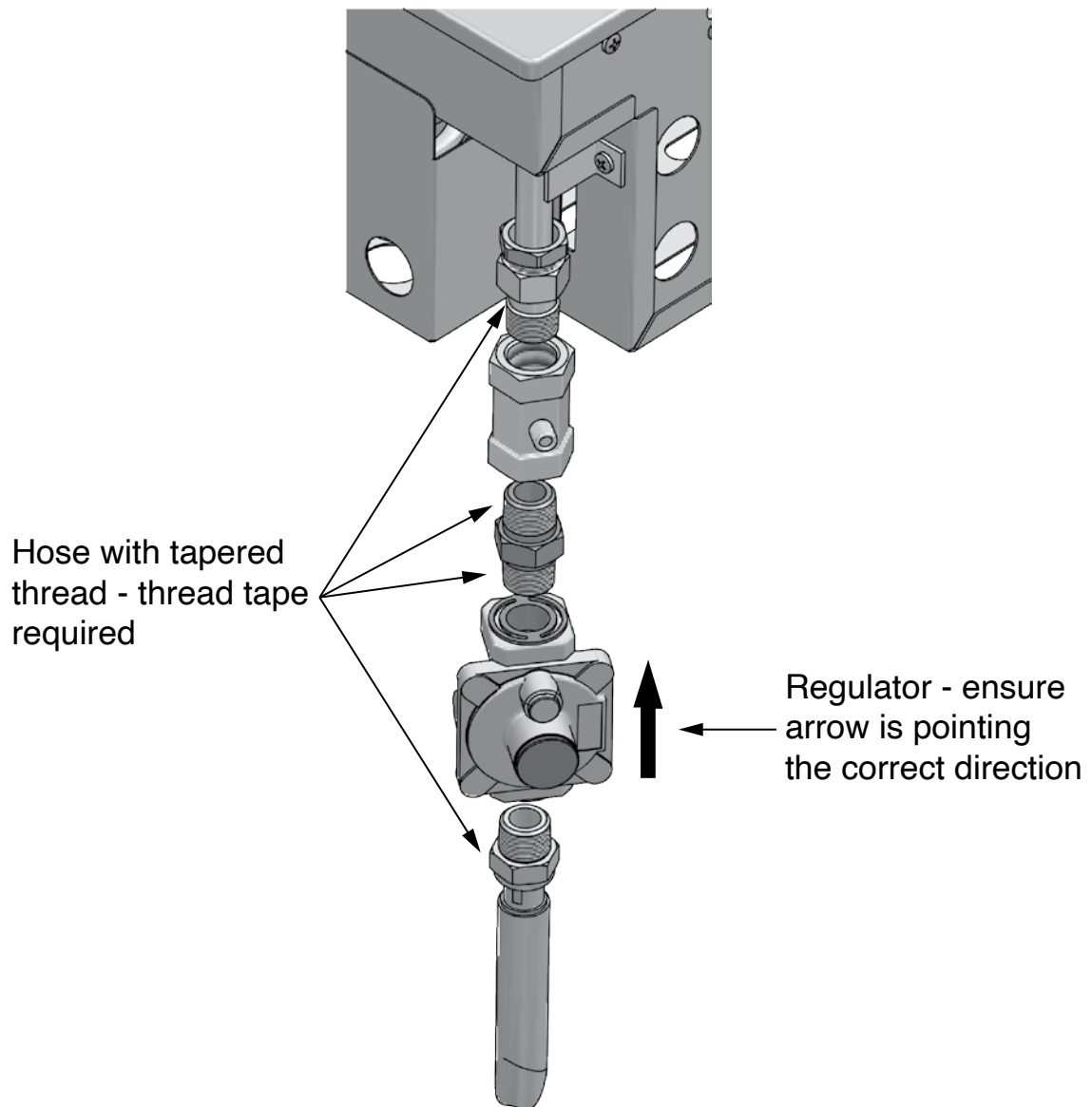

- Disconnect and disassembled/remove plates, burners etc.
- Remove injectors and replace with correct sizes for each burner.
- Adjust aeration (X) per every burner
- Re-assemble burners.
- Turn gas on and test for leaks, repair if necessary.
- Light the burners and set the pressure to 1,00kPa.
- Turn burner "Low" setting and adjust setting accordingly.
- Check operation of ignition etc.
- Ensure data plate is changed with the new data plates supplied in the product.

For Natural Gas connection a bayonet connection point should be installed by a licensed gas fitter prior to installing the barbecue unit.

# ADJUSTING THE GAS

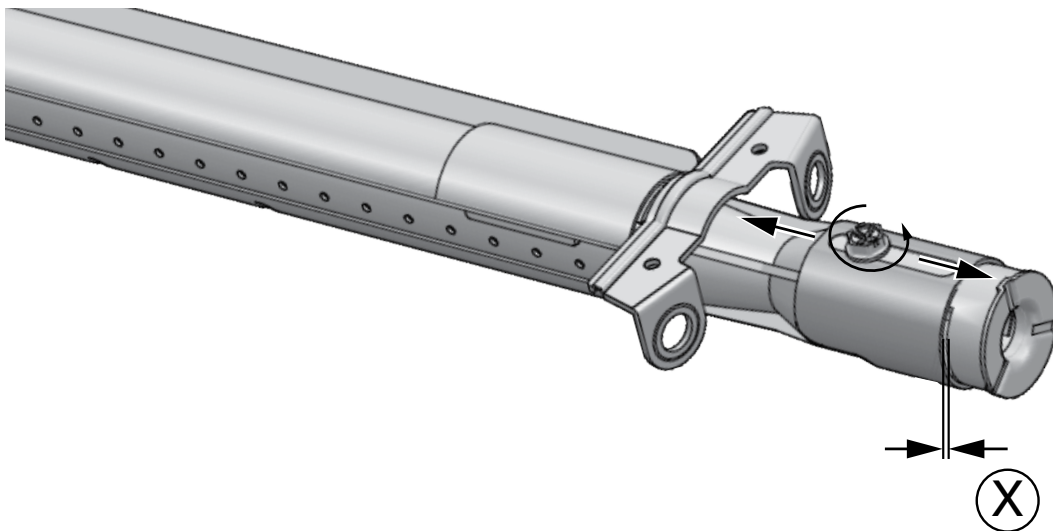
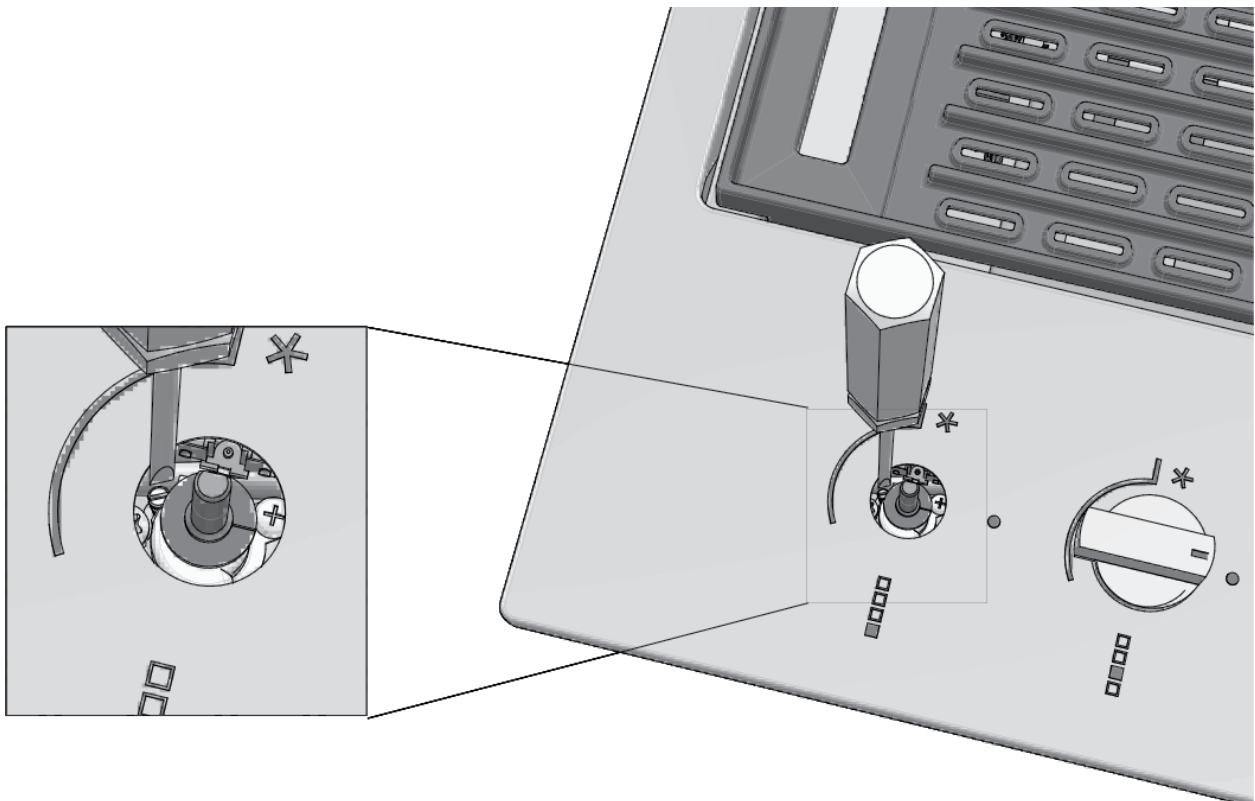
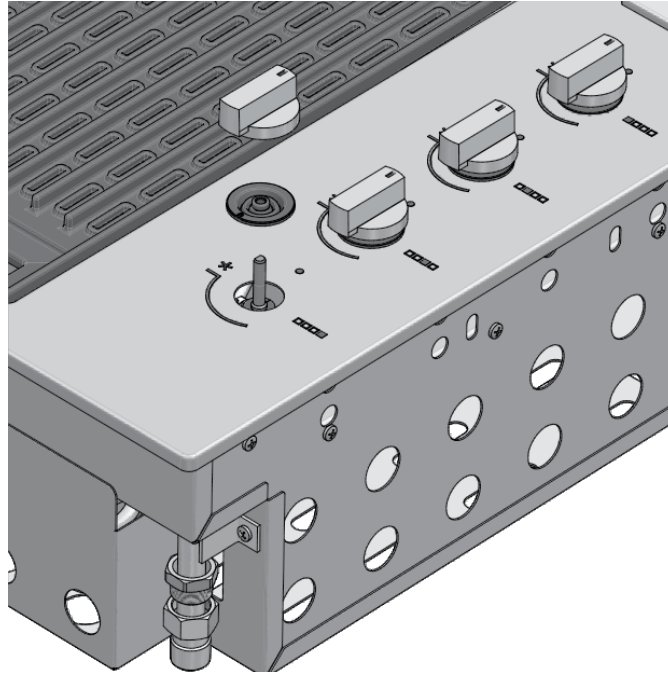

## **GAS CYLINDER SAFETY INFORMATION (OUTDOOR USE ONLY)**

- When converted for the use of universal LPG, the appliance is designed to use different types of cylinders depending on the installation made. See the chapters on Installation Preparation and Connection of the cylinder.
- The gas cylinder must be manufactured and marked in accordance with the specifications for LPG cylinders.
- The shut-off valve must be closed when the appliance is not in use.
- The gas cylinders must be kept in an approved housing out of the reach of children.
- When you disconnect the gas cylinder, make sure all the control valves are in the “OFF” (O) position.
- Before disconnecting, remove the cylinder from any housing in which it may be located.
- When you reconnect the hose to the cylinder, make sure all the connections are tight before placing it back in its compartment.
- After each connection of a cylinder, perform a leak test as described below.

### **LEAK TESTING PROCEDURE**

- Make sure that all the gas taps are in the “OFF” (O) position.
- Mix a solution of water and detergent or soap in a small container.
- After connecting the hose, open the valve on the gas cylinder or gas system tap.
- Using a brush, paint the solution on the gas connection points and check for bubbles.
- Bubbles indicate a leak.
- Close the valve and tighten the fitting, possibly inserting a new gasket. Repeat the leak test.
- If the leak persists, turn off the gas and contact an authorized gas system maintenance technician to repair the leak.

# INSTALLATION INSTRUCTIONS AND WARNINGS (INDOOR USE ONLY)



- If the barbecue is exposed to the weather we recommend the PVC cover is used. This is available as an optional extra; product codes are BBQCOVER-F for the flat lid. Available to purchase at [www.artusi.com.au](http://www.artusi.com.au)
- Recommended range hoods option extra

**ARTUSI 120 cm BBQ canopy range hood, model ACH12BBQ**

**ARTUSI 120 cm wall mounted BBQ range hood, model ACH12BBQB**

## SELECTION OF THE POINT OF INSTALLATION

- The appliance must not be installed on non-combustible materials. The minimum distance from combustible materials is 1200mm overhead, 200mm sides and 200mm rear.
- The appliance must be installed in accordance with standards and local deviations.
- Ventilation must be ensured on both LPG & NG. Gas is highly explosive and can cause serious personal injury and property damage if it is left to accumulate and then ignited.
- The barbecue is designed to be mounted in a counter with a minimum depth of 600mm.
- Avoid locations exposed to the wind as this may affect cooking and the efficiency of the burners. If you cannot avoid such a location, screens may be necessary.

## INSTALLATION COMPARTMENT

- The barbecue requires a non-combustible barrier beneath it to prevent reaching excessive temperatures. The panel that acts as a barrier must be positioned 30/35 mm below the base of the unit.
- The installation compartment must be made of non-combustible materials. Materials suitable for its construction include brick, granite, marble, Hardiplank® and Villaboard® on a metal or brick structure.
- The appliance requires ventilation openings in the front wall of the compartment. See the drawing on page 28 for the details.
- The appliance unit can be mounted in an island counter or a counter with splash guard. Read the specific requirements for each type of mounting.
- When mounting the appliance against a wall, it is essential to insulate combustible materials. All combustible materials must be kept at least 1200mm overhead, 200mm sides and 200mm rear away from the barbecue.
- The minimum depth of the mounting surface (counter) is 600 mm
- The required dimensions of the cut-out vary from model to model, please see dimension drawings for more information.

## ISLAND-MOUNTED

- If the appliance is installed in an island, it can be placed in the centre. Pay particular attention to the overall dimensions of the top of the island, taking into account the open lid and its projection. See page 26.
- The required dimensions of the cut-out vary from model to model, please see dimension drawings for more information.

**NB:** Use of engineered stone (e.g. Cesar stone) as a bench top is permitted providing temperatures upto 120°C are tolerated

# INSTALLATION INSTRUCTIONS AND WARNINGS (INDOOR USE ONLY)

AS/NZS 5601 clause 6.10.1.7

## BARBECUES IN RESIDENTIAL PREMISES

Barbecues in residential premises shall be installed such that—

- (a) measured horizontally, a vertical combustible surface less than 200 mm from the cooking surface area is protected in accordance with Clause 6.10.1.2 for a height of 150 mm; and
- (b) the clearances shown in Table 6.8 are observed.

### NOTES:

- 1. This Clause (6.10.1.7) applies to gas appliances designed for use without a cooking vessel where cooking fats can fall on to and flare up from a heated perforated plate, volcanic rock or similar refractory material.
- 2. Any combustible surfaces less than 1200 mm but not less than 600 mm from the cooking surface may be protected in accordance with Clause 6.10.1.2. The 'cooking surface area' is defined as that part of the gas appliance where cooking normally takes place and does not include those parts of the gas appliance containing control knobs.

This appliance must be installed by an authorised person in accordance with this instruction manual, AS/NZS 5601 – Gas installations (installation and pipe sizing), local gas fitting regulations, local electrical regulations, local water regulations, local health regulations, Building Code of Australia and any other government authority.

This appliance is suitable for connection with rigid pipe or flexible hose. The isolating manual shut-off valve connection point must be accessible when the appliance is installed. Flexible hose assembly must be certified to AS/NZS 1869 class B or D, be of appropriate internal diameter for the total gas consumption, be kept as short as possible (not exceeding 1200mm), must not be in contact with the floor or any hot or sharp surfaces. The hose assembly must not be subject to strain, abrasion, kinking or deformation.

Natural Gas: the supplied regulator must be fitted to the appliance inlet connection. Gas pressure must be adjusted to 1.0 kPa when approximately 50% of the burners are on high flame, the appliance test point is located on the regulator.

ULPG: the supplied test point adaptor must be fitted to the appliance inlet connection. Gas pressure must be adjusted to 2.75 kPa, the appliance test point is located on the test point adaptor.

Gas leakage and operation of the appliance must be tested by the installer before leaving. Check burner flames are blue in colour, stable and completely ignite at both high and low flame settings with no appreciable yellow tipping, carbon deposition, lifting, floating, lighting back or objectionable odour. Test burners individually and in combination, When satisfied with the operation of the cooker, please instruct the user on the correct method of operation.

Overhead clearances—(Measurement A) Range hoods and exhaust fans shall be installed in accordance with the manufacturer's relevant instructions. However, in no case shall the clearance between the highest part of the barbecue and a range hood be less than 1200 mm, for an overhead exhaust fan, 1200mm.

Side clearances—(Measurements B, & C) Where B, measured from the edge of appliance to any vertical combustible surface, or vertical combustible surface covered with toughened glass or sheet metal, is less than 200 mm, the surface shall be protected to a height C of not less than 150 mm above the hob for the full dimension (width or depth) of the cooking surface area.

**NB:** Use of engineered stone (e.g. Caesar stone) as a bench top is permitted providing temperatures upto 120°C are tolerated



TO FACILITATE INSERTION IN THE CABINET, THE PRODUCT HAS SPECIFIC LIFTING HANDLES (SEE FIGURE BELOW)

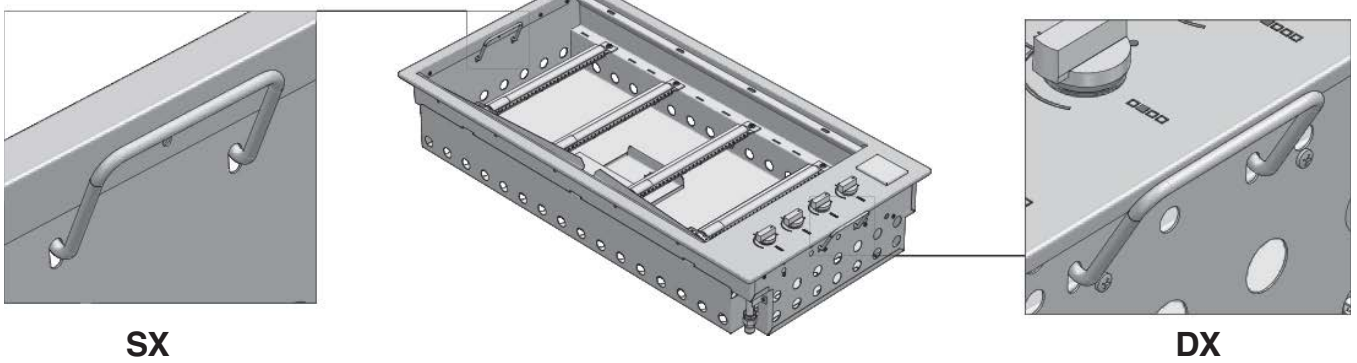

**SX**

**DX**

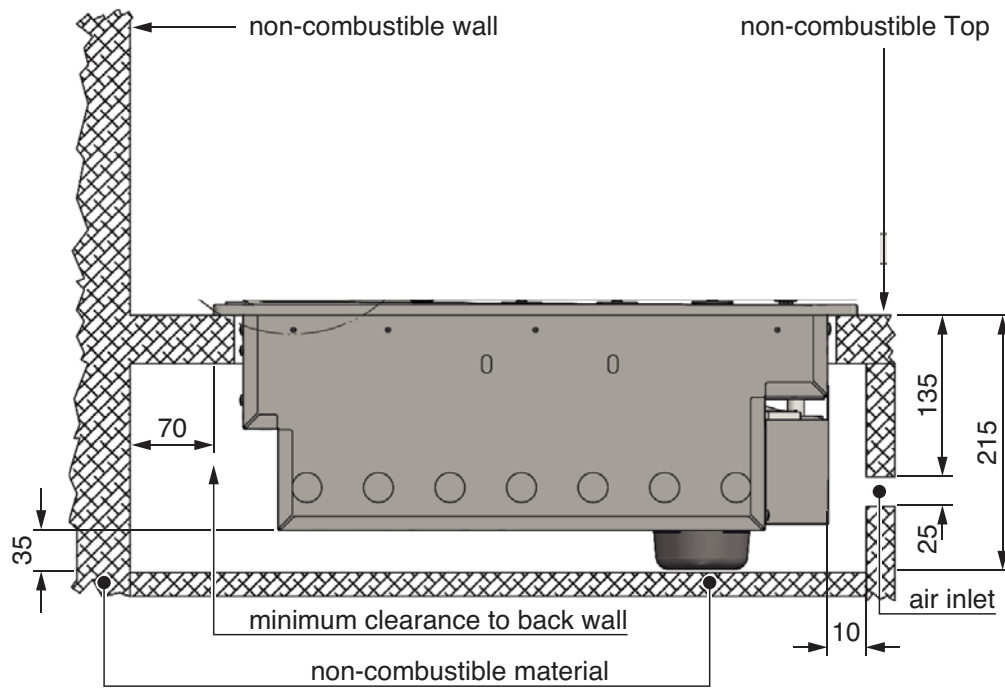

**FRONT**

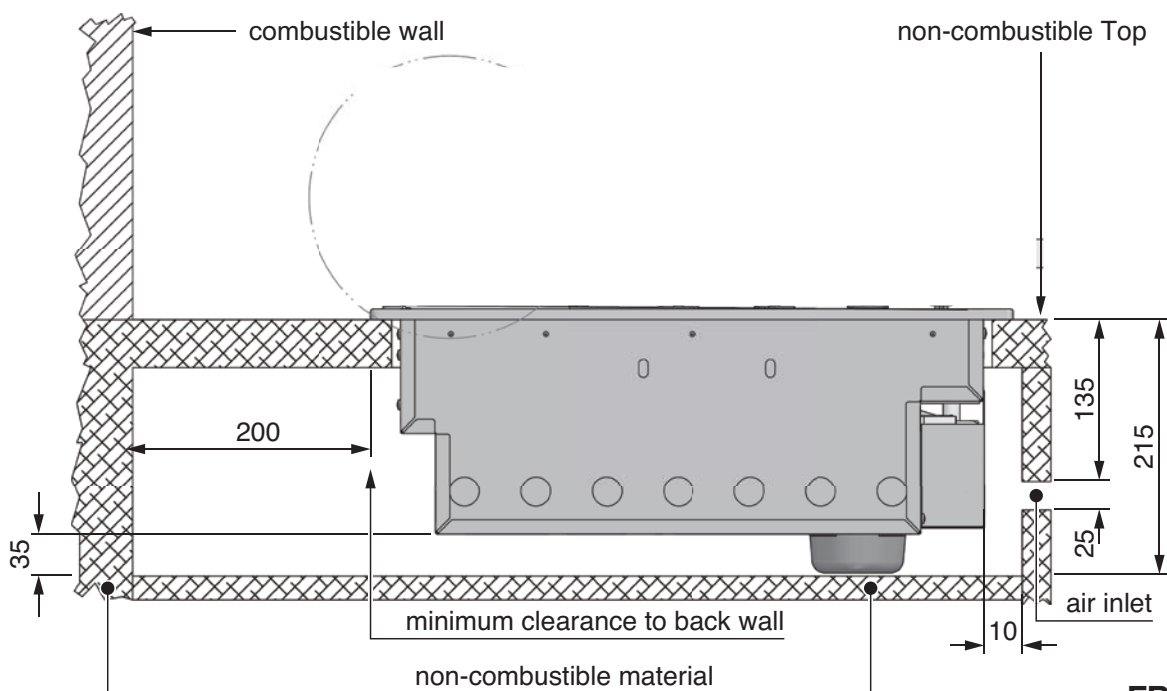

**FRONT**

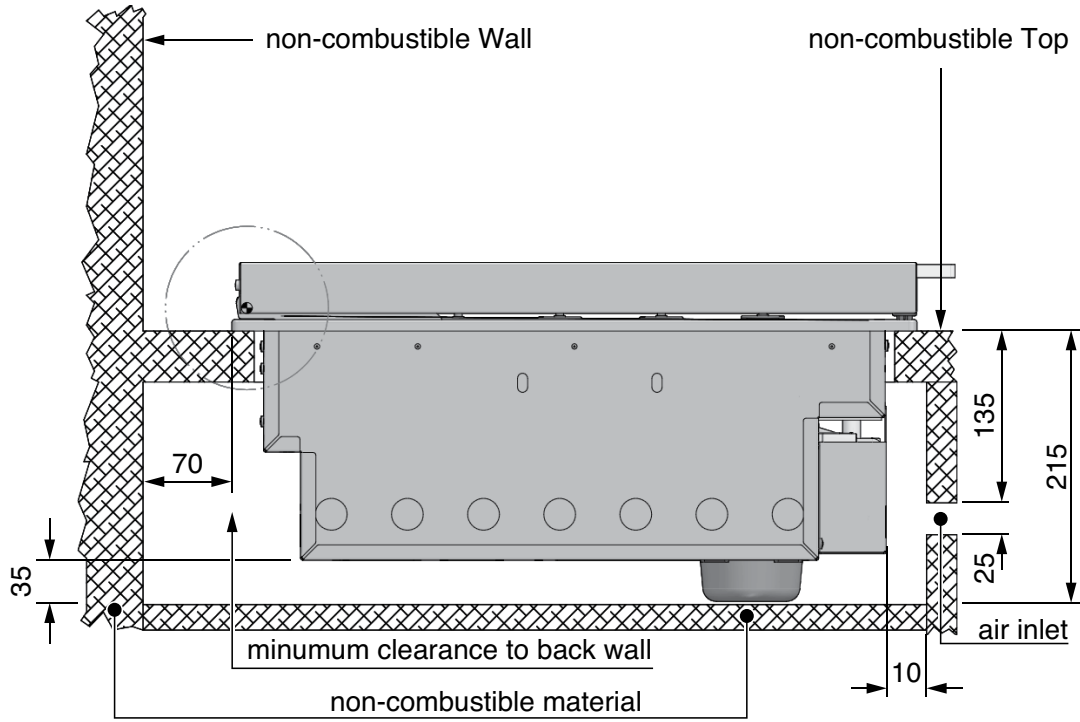

**FRONT**

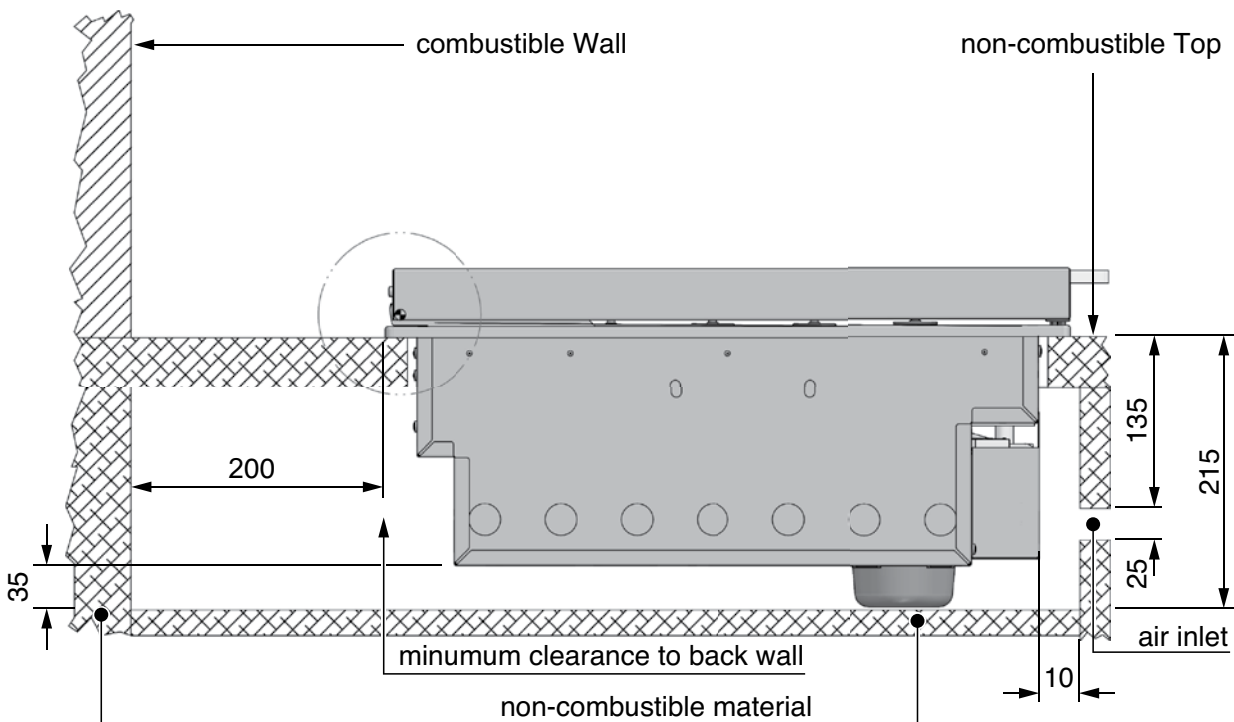

**FRONT**

# INSTALLATION INSTRUCTIONS AND WARNINGS: OUTDOOR INSTALLATION



- The appliance must only be used above ground level, in open air and natural ventilation without stagnant areas where leaking gas and combustion products are rapidly dispersed by the wind or natural convection. Refer to the drawings below.
- Never install the barbecue inside buildings, garages, sheds or covered walkways, or in a boat, camper or caravan, unless indoor installation rules are followed. This prevents the creation of fires or carbon monoxide with toxic effects or asphyxiation.
- The compartment in which the appliance is installed must conform to one of the following requirements:
  - A compartment with walls on all sides, but with at least one permanent opening at ground level and without upper cover.
  - In a partial compartment that has a top cover and not more than two walls.
  - In a partial compartment that has a top cover and not more than two walls; in this case, the following principle applies:
    - At least 25% of the total area of the walls is completely open and at least 30% of the remaining area of the walls is open and free.
- In the case of balconies, at least 20% of the total area of the side, front and rear walls must be and remain open and free.

External surface area example 1

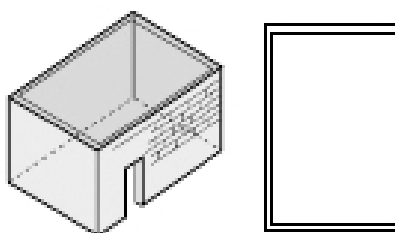

External surface area example 2

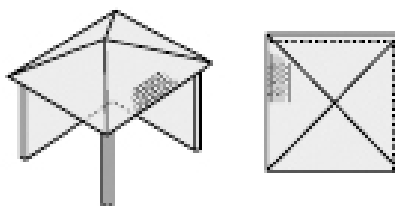

External surface area example 3

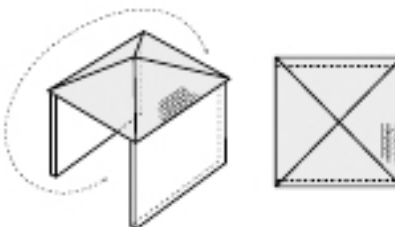

both ends open

External surface area example 4

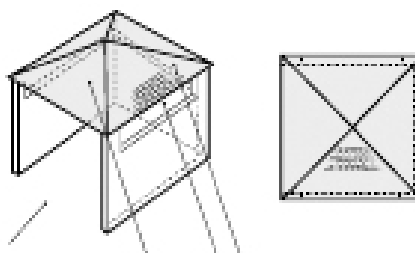

open side for at least 25% of the total area of the walls in total 30% or more of the remaining surface of the walls is open and free

External surface area example 5

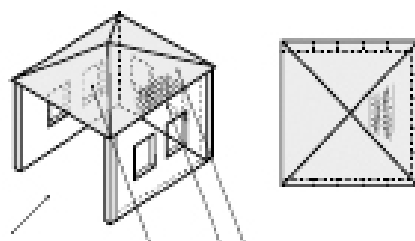

open side for at least 25% of the total area of the walls in total 30% or more of the remaining surface of the walls is open and free

## SELECTION OF THE POINT OF INSTALLATION

# INSTALLATION INSTRUCTIONS AND WARNINGS (OUTDOOR USE ONLY)

- The appliance must not be installed on combustible materials. \*The minimum distance from combustible materials is 600 mm overhead, 300 mm sides and 200 mm rear.
- The free space above the cooking surface with respect to combustible materials must be at least 600 mm.
- The appliance must be installed in accordance with standards and local deviations.
- When using LPG, ventilation must be ensured in the compartment. The gas is highly explosive and can cause serious personal injury and property damage if it is left to accumulate and then ignited.
- Avoid locations exposed to the wind as this may affect cooking and the efficiency of the burners. If you cannot avoid such a location, screens may be necessary.

## INSTALLATION COMPARTMENT

- The barbecue requires a non-combustible barrier beneath it to prevent reaching an excessive temperature. The panel that acts as a barrier must be positioned 30/35 mm below the base of the unit.
- The installation compartment must be made of non-combustible materials. Materials suitable for its construction include brick, granite, marble, Hardiplank® and Villaboard®.
- The appliance requires ventilation openings in the front wall of the compartment. See the drawing on page 32 for details.
- The appliance unit can be mounted in an island counter or a counter with splash guard. Read the specific requirements for each type of mounting.

## ISLAND-MOUNTED

- If the appliance is installed in an island, it can be placed in the centre. Pay particular attention to the overall dimensions of the top of the island, taking into account the open lid and its projection. See page 29.
- The required dimensions of the cut-out are 1025 mm x 505 mm for model 100 cm, 800 mm x 505 mm for mod. 80 cm and 585 mm x 505 mm for mod. 60cm (see drawing page. 31).

## INSTALLATION IN A COUNTER IN A SPECIAL CONTEXT

- The context must be made of non-combustible material.
- When mounting the appliance against a wall or a fence, it is essential to insulate combustible materials. All combustible materials must be kept at least 1200mm overhead, 200mm side & 200mm rear away from the barbecue.
- The required dimensions of the cut-out are 1025 mm x 505 mm for model 100cm, 800 mm x 505 mm for mod. 80 cm and 585 mm x 505mm for mod. 60cm (see drawing page. 32).
- Models with high cooking cover require a specific free space on the back of the barbecue between the splash guard and the cut-out of the counter of at least 70 mm. This, so that the hood has the free space needed to open.

**NB:** Use of engineered stone (e.g. Cesar stone) as a bench top is permitted providing temperatures upto 120°C are tolerated

To facilitate insertion in the cabinet, the product has specific lifting handles (see figure below)

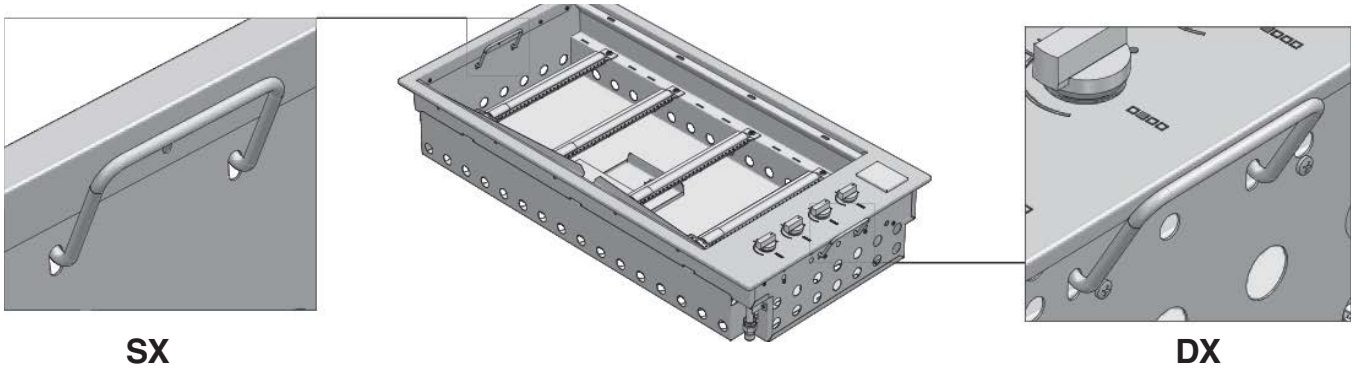

**SX**

**DX**

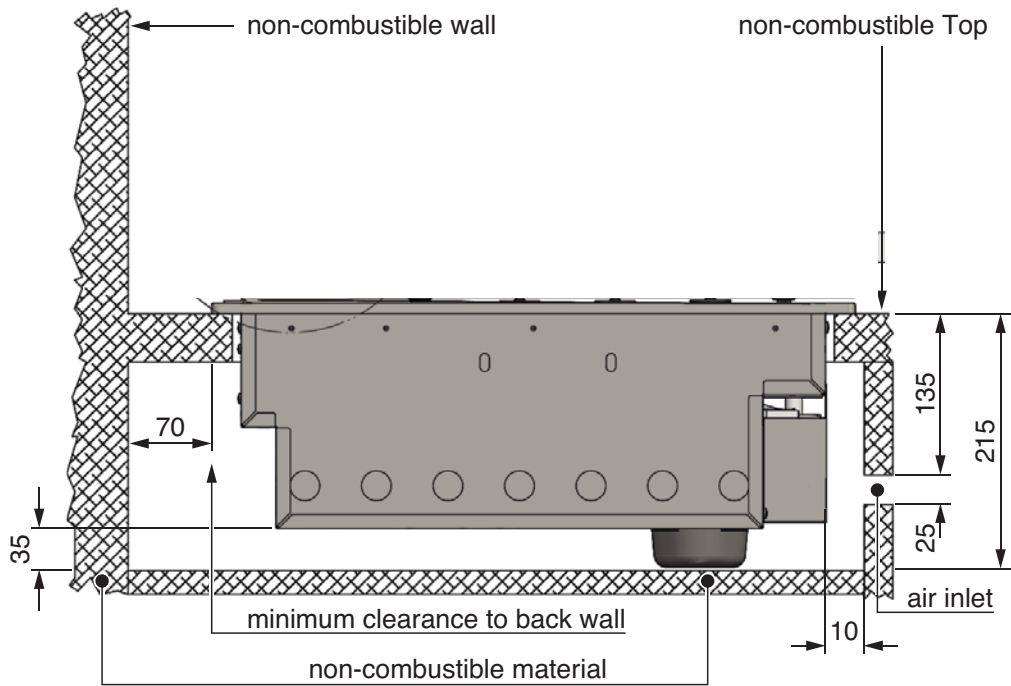

**FRONT**

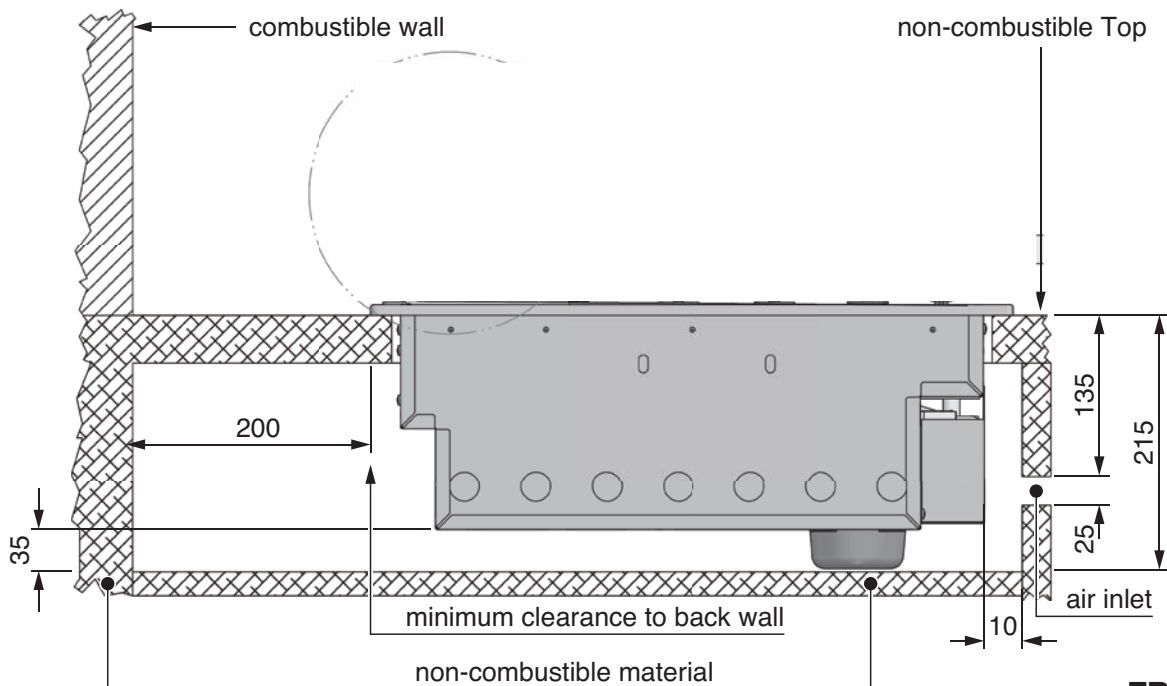

**FRONT**

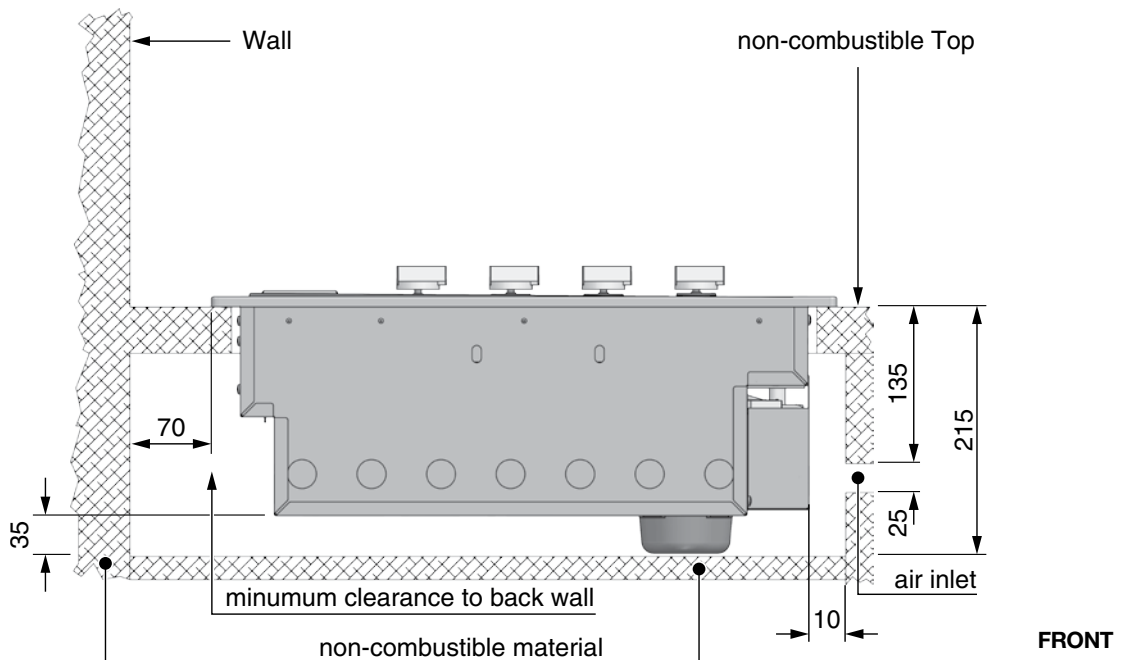
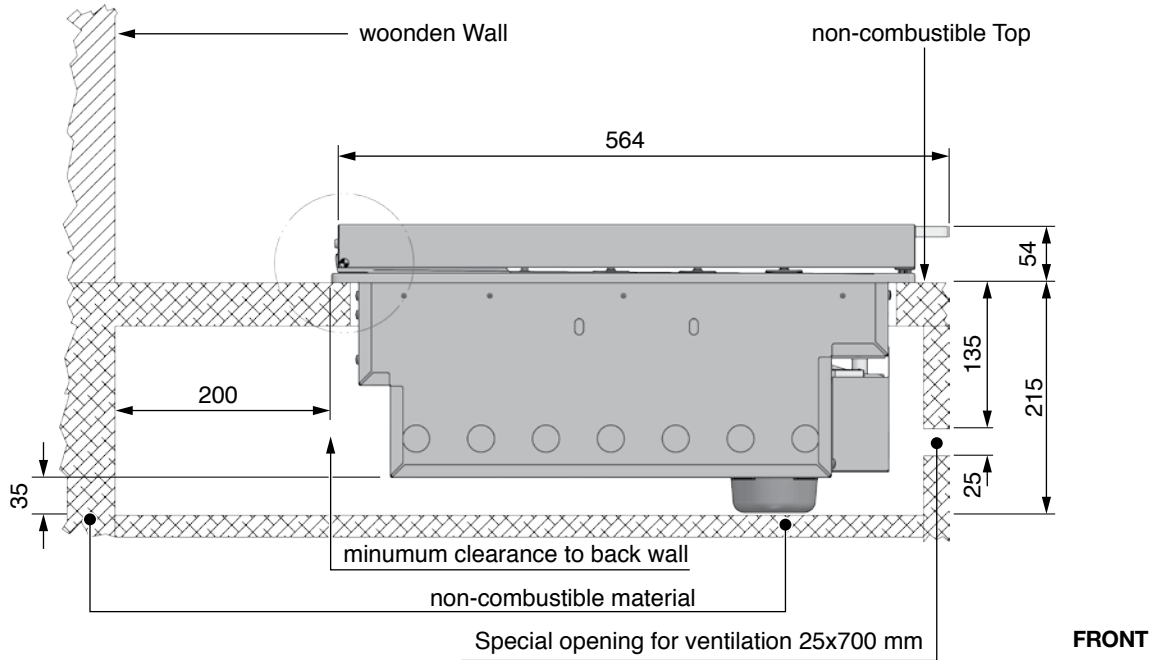
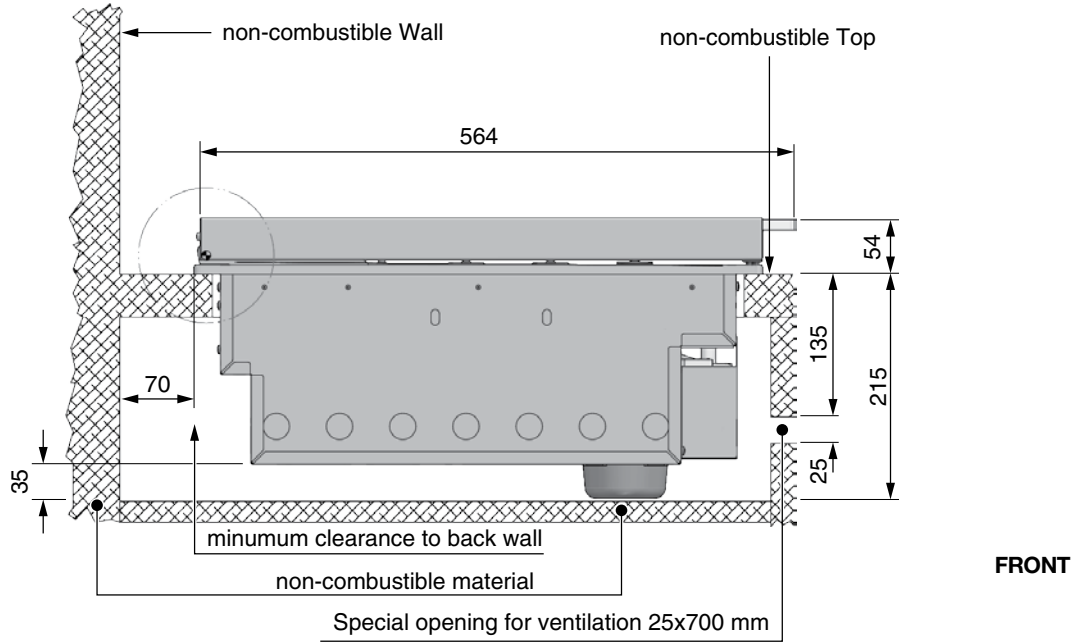



**ATTENTION**

- The appliance requires adequate ventilation. An open area must be provided as shown on page 28-29. A ventilation grate can be applied, if desired. This ventilation surface allows air to enter the compartment for the proper combustion of the gas and aspiration of the combustion products. In the case of LPG, the gas is heavier than air; in the event of a leak the vent allows the gas to leave the compartment. The air vent must be at least 700 mm x 25 mm and placed in a central position 135 mm below the mounting surface. (See drawing on page 28-29).

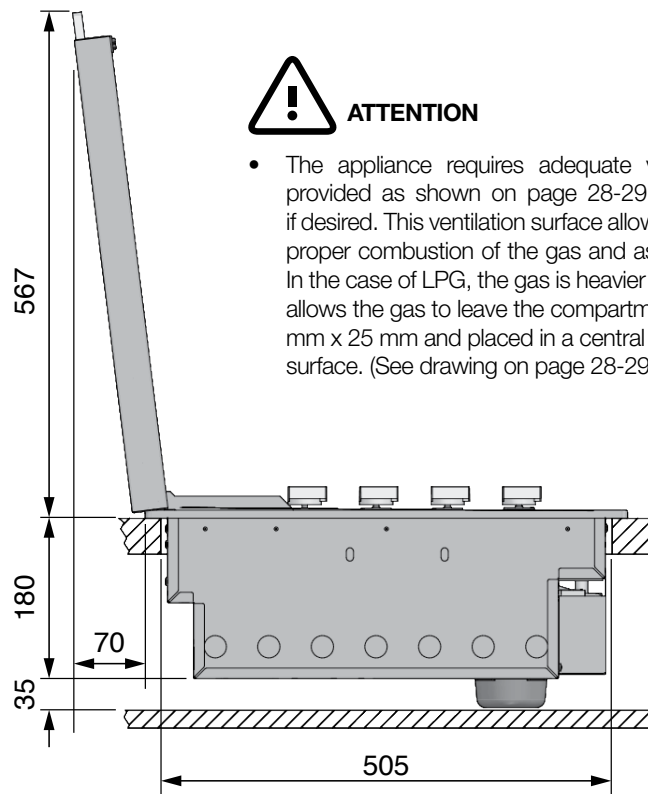

**Model BBQ 102cm**

Minimum distance  
From wall for cover rotation

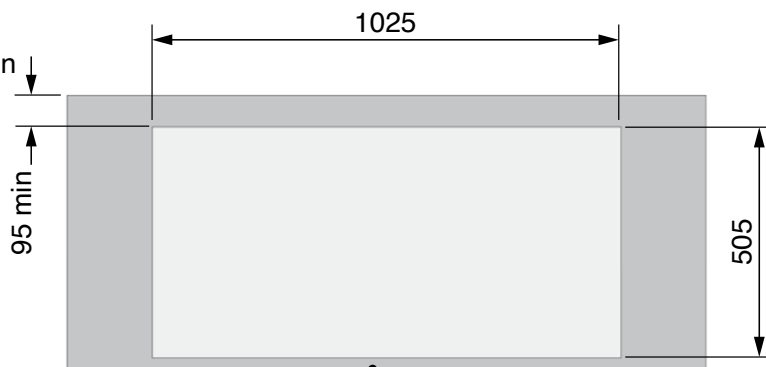

FRONT

**Model BBQ 80 cm**

Minimum distance  
From wall for cover rotation

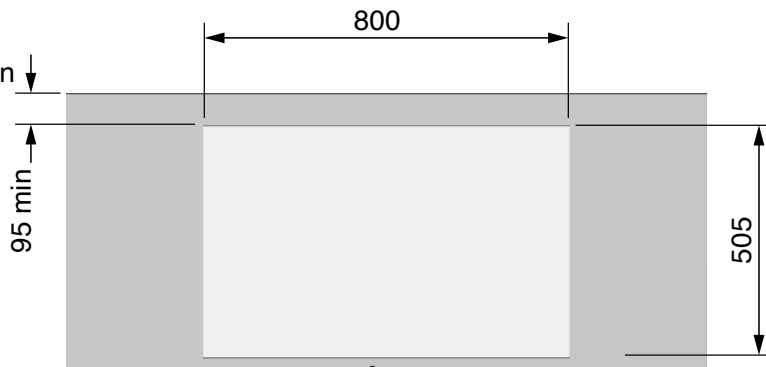

FRONT

**Model BBQ 60 cm**

Minimum distance  
From wall for cover rotation

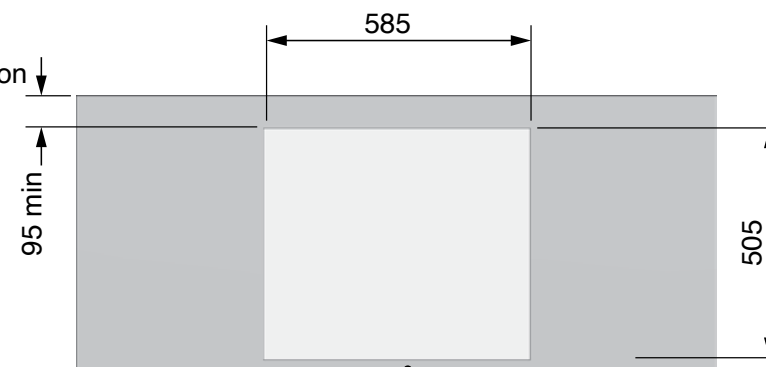

FRONT

# OUTDOOR USE ONLY

## Model BBQ 60cm, 80cm100cm

The cylinder compartment must be ventilated in accordance with AS/NZS 5601, (Appendix J - Clause J3 - 4: Cylinders in an enclosure or recess), with the free ventilation area having at least 20,000 squared mm at high and low level.

Cylinder compartments shall have permanent openings ventilating directly to outside and consisting of either of the following:

(A) Perforations, uniformly distributed over the height of the enclosure and with a total free area not less than 25% of the side wall area.

(B) Separate openings at a high and low level, such that –  
 (i) the total free area at high level is not less than 20,000mm<sup>2</sup> and is within 125mm on the top of the cylinder compartment; and  
 (ii) the total free area at the low level is not less than 20,000mm<sup>2</sup>, and –  
 (A) at least 25% of the required area is within 15mm of the base of the cylinder compartment.  
 (B) the total required area is within 125mm of the base of the cylinder compartment; and (C) the openings cannot be obstructed by the cylinder(s)

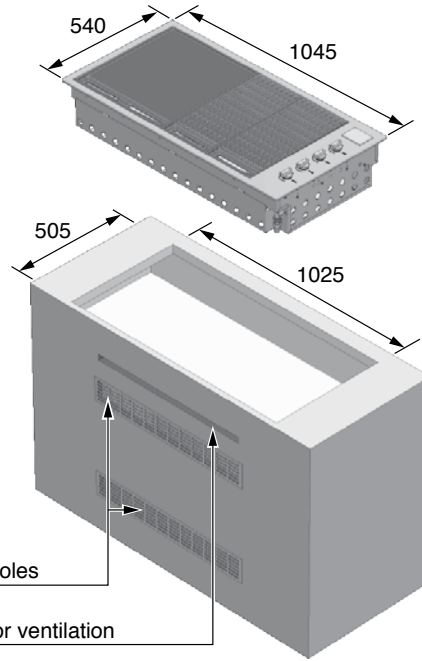

## Model BBQ 80 cm

Cylinder compartments shall have permanent openings ventilating directly to outside and consisting of either of the following:

(A) Perforations, uniformly distributed over the height of the enclosure and with a total free area not less than 25% of the side wall area.

(B) Separate openings at a high and low level, such that –  
 (i) the total free area at high level is not less than 20,000mm<sup>2</sup> and is within 125mm on the top of the cylinder compartment; and  
 (ii) the total free area at the low level is not less than 20,000mm<sup>2</sup>, and –  
 (A) at least 25% of the required area is within 15mm of the base of the cylinder compartment.  
 (B) the total required area is within 125mm of the base of the cylinder compartment; and  
 (C) the openings cannot be obstructed by the cylinder(s)

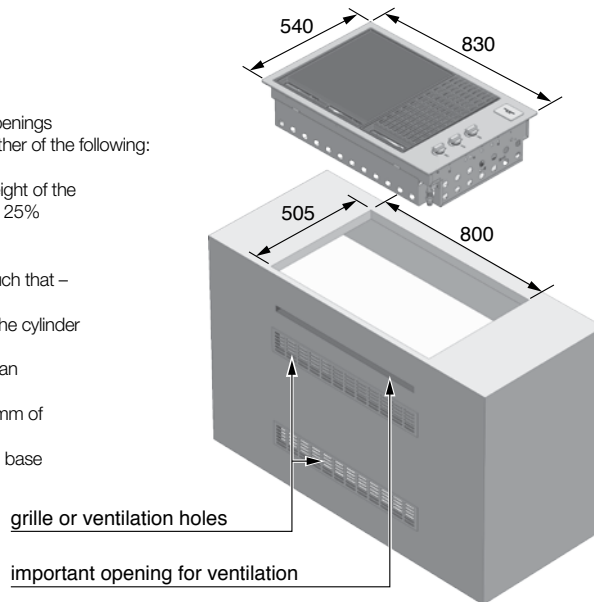

## Model BBQ 60 cm

Cylinder compartments shall have permanent openings ventilating directly to outside and consisting of either of the following:

(A) Perforations, uniformly distributed over the height of the enclosure and with a total free area not less than 25% of the side wall area.

(B) Separate openings at a high and low level, such that –  
 (i) the total free area at high level is not less than 20,000mm<sup>2</sup> and is within 125mm on the top of the cylinder compartment; and  
 (ii) the total free area at the low level is not less than 20,000mm<sup>2</sup>, and –  
 (A) at least 25% of the required area is within 15mm of the base of the cylinder compartment.  
 (B) the total required area is within 125mm of the base of the cylinder compartment; and  
 (C) the openings cannot be obstructed by the cylinder(s)

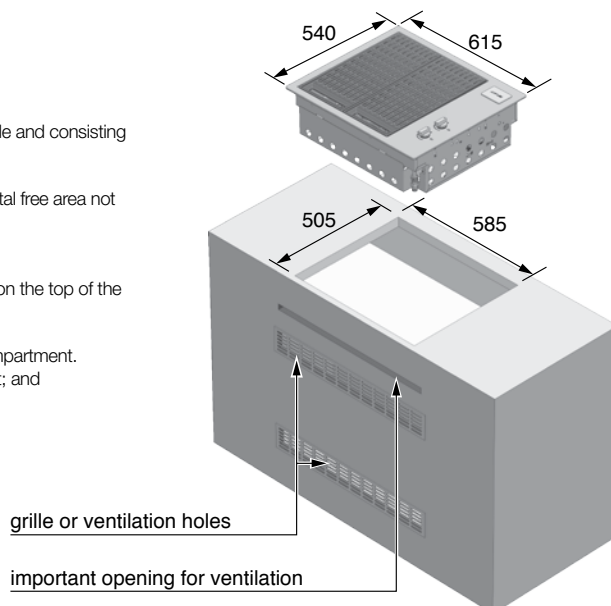



## OUTDOOR USE ONLY

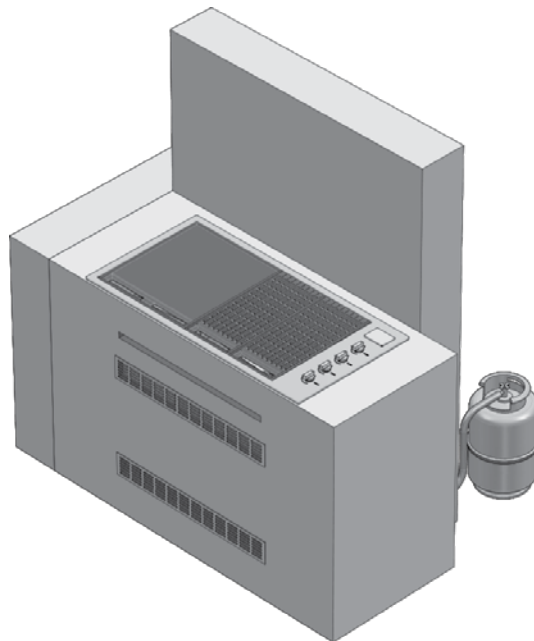
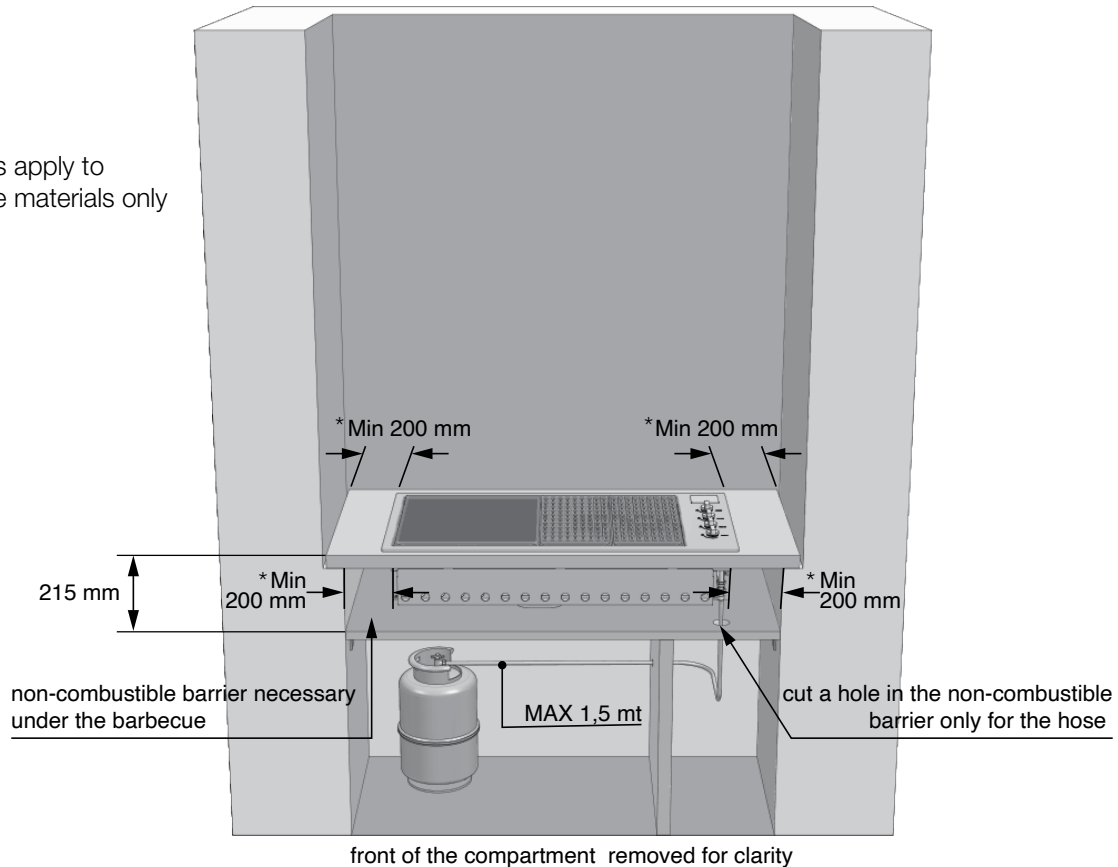

The LPG cylinder may be connected inside the object-holder compartment of barbecue only if it has the dimensions shown in the guidelines. The safe use of a cylinder inside the object-holder compartment of the barbecue depends on several factors: A) The base of the cylinder must be properly inserted between the plates and be horizontal on the base panel.

### DIMENSIONS OF THE CYLINDER

Max height 465 mm

Width 289 mm - (rectangular section) or 318 mm (circular section) maximum B) Capacity of the cylinder max 6 kg

There are several models of cylinders with approved dimensions (2).

**WARNING:** if the LPG cylinder purchased does not have the required dimensions, do not attempt to connect it inside the object-holder compartment. Fix the cylinder to the bracket or rest it on the floor. Failure to follow these instructions could damage the hose and cause fire or explosion, with serious injury or death and property damage.

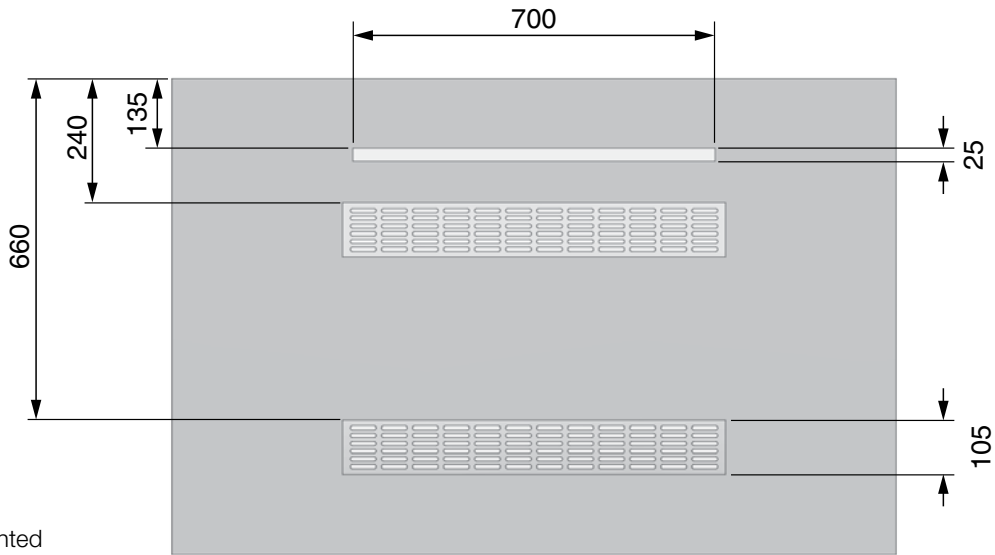

**! ATTENTION**

The compartment below the barbecue unit must be isolated from the barbecue by a non-combustible panel. The compartment must comply with the requirements of AS/NZS 5601.

**FOR INDOOR OR OUTDOOR INSTALLATION**

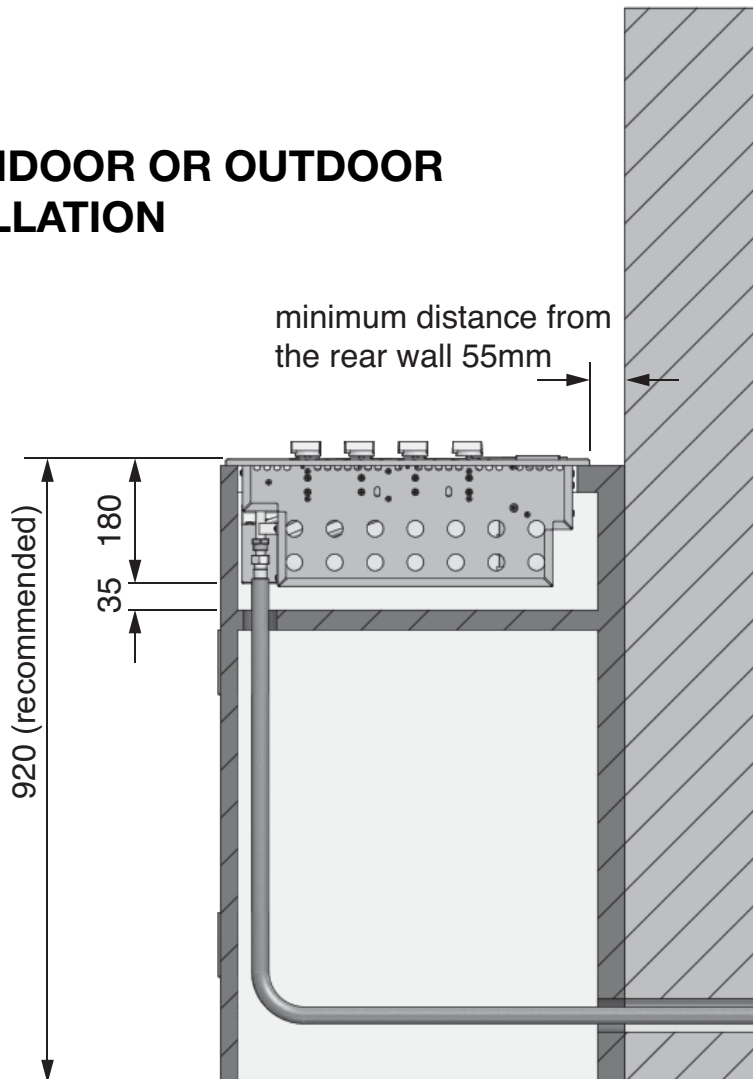

# FOR INDOOR OR OUTDOOR INSTALLATION

\* clearances apply to  
combustible materials only

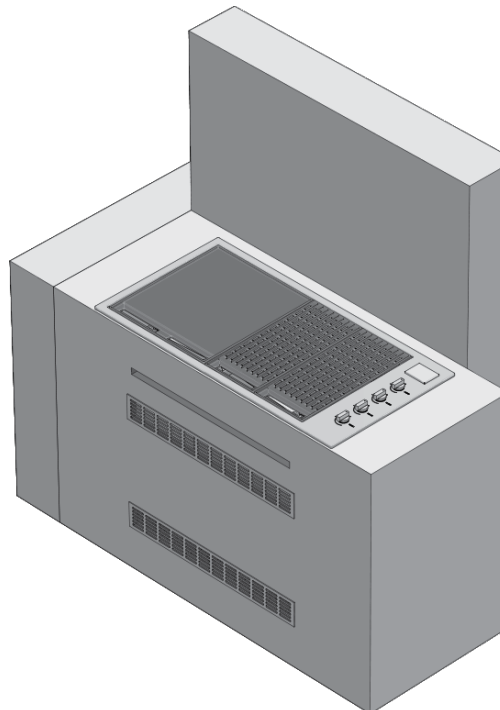
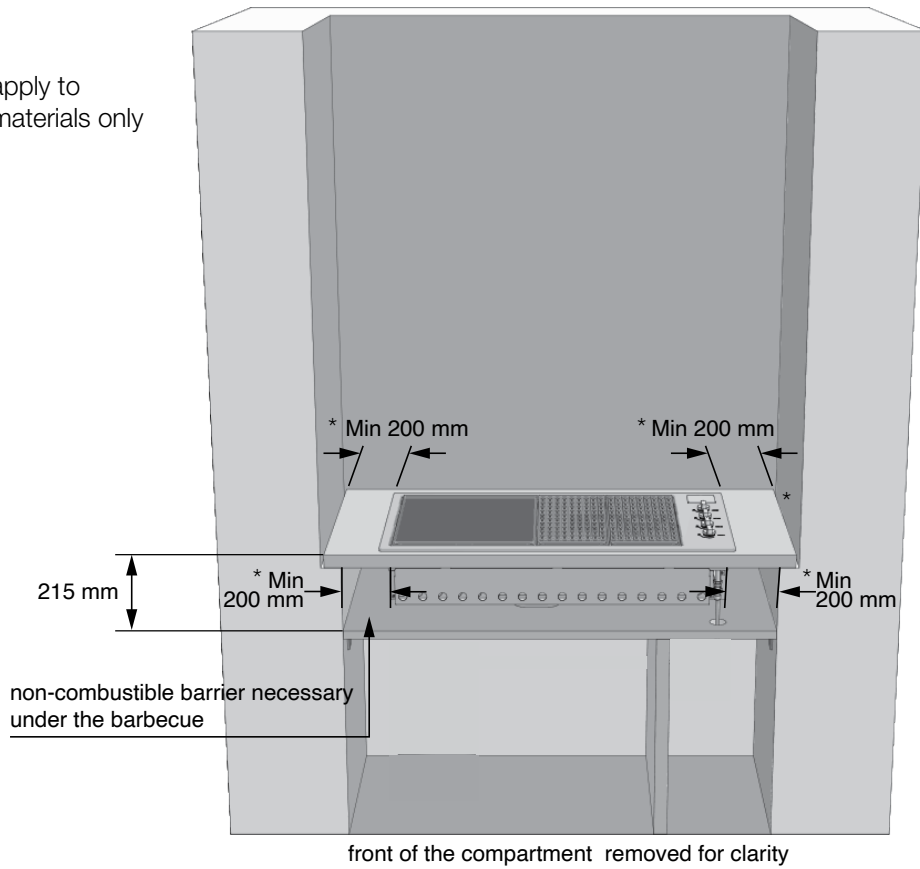

## APPLICATION OF THE THIN COVER

### APPLICATION OF THE LOW COVER

- Remove the thin cover from the packaging.
- Attach the hinges to the outer frame and secure it with the special screw provided.

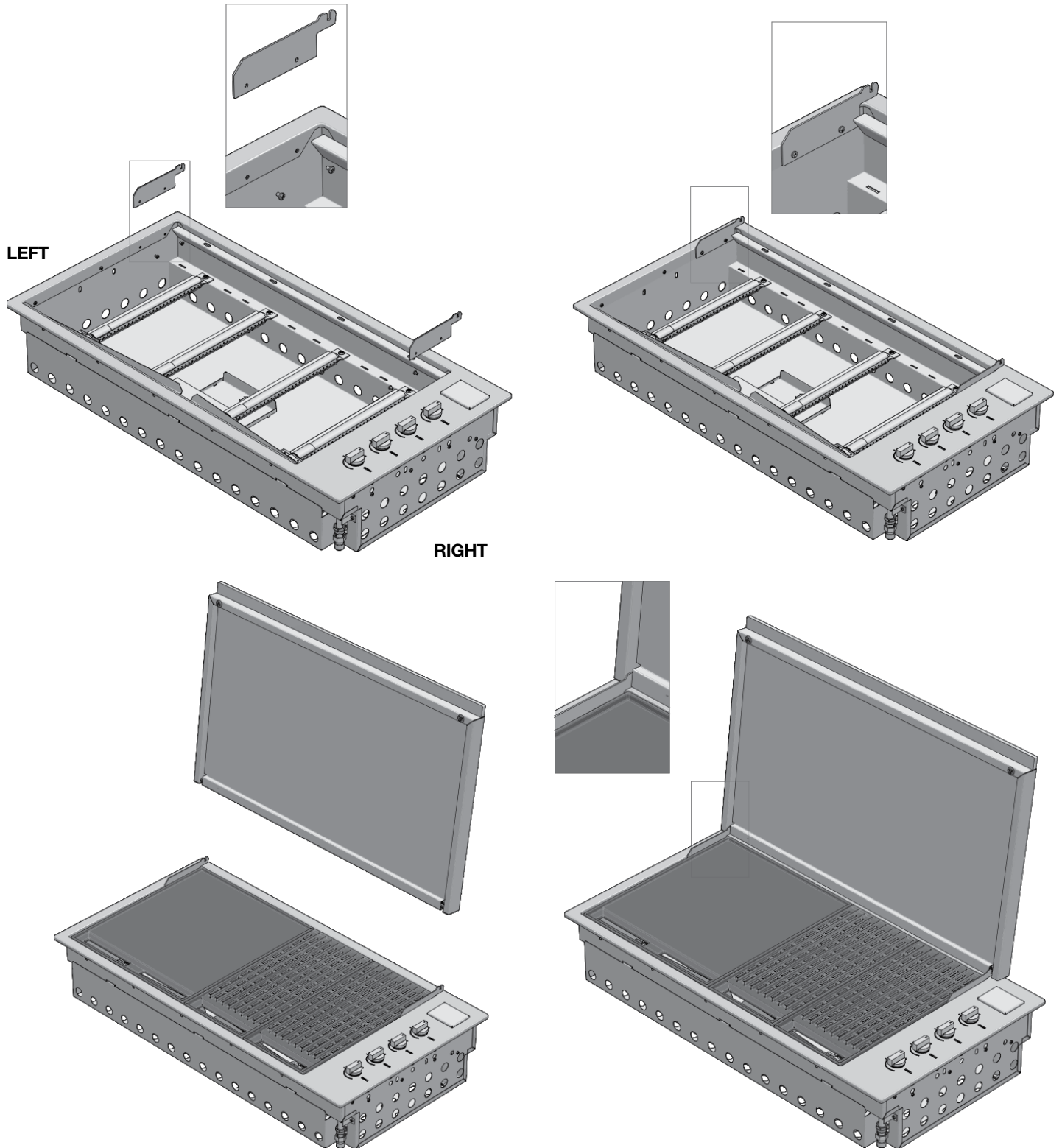

### APPLICATION OF THE HIGH COVER

- Remove the High cover from the packaging.
- Remove the hinge from the cover and apply it to the outer frame. Fix it with the special screws provided.
- Insert the cover into the seats of the hinge.

## APPLICATION OF THE DOME COVER (OUTDOOR USE ONLY)

**! IMPORTANT**

- Given the dimensions of the cooking hood, we recommend that two people position it.
- During positioning the high cover group, take special care to avoid scratching the external profile.

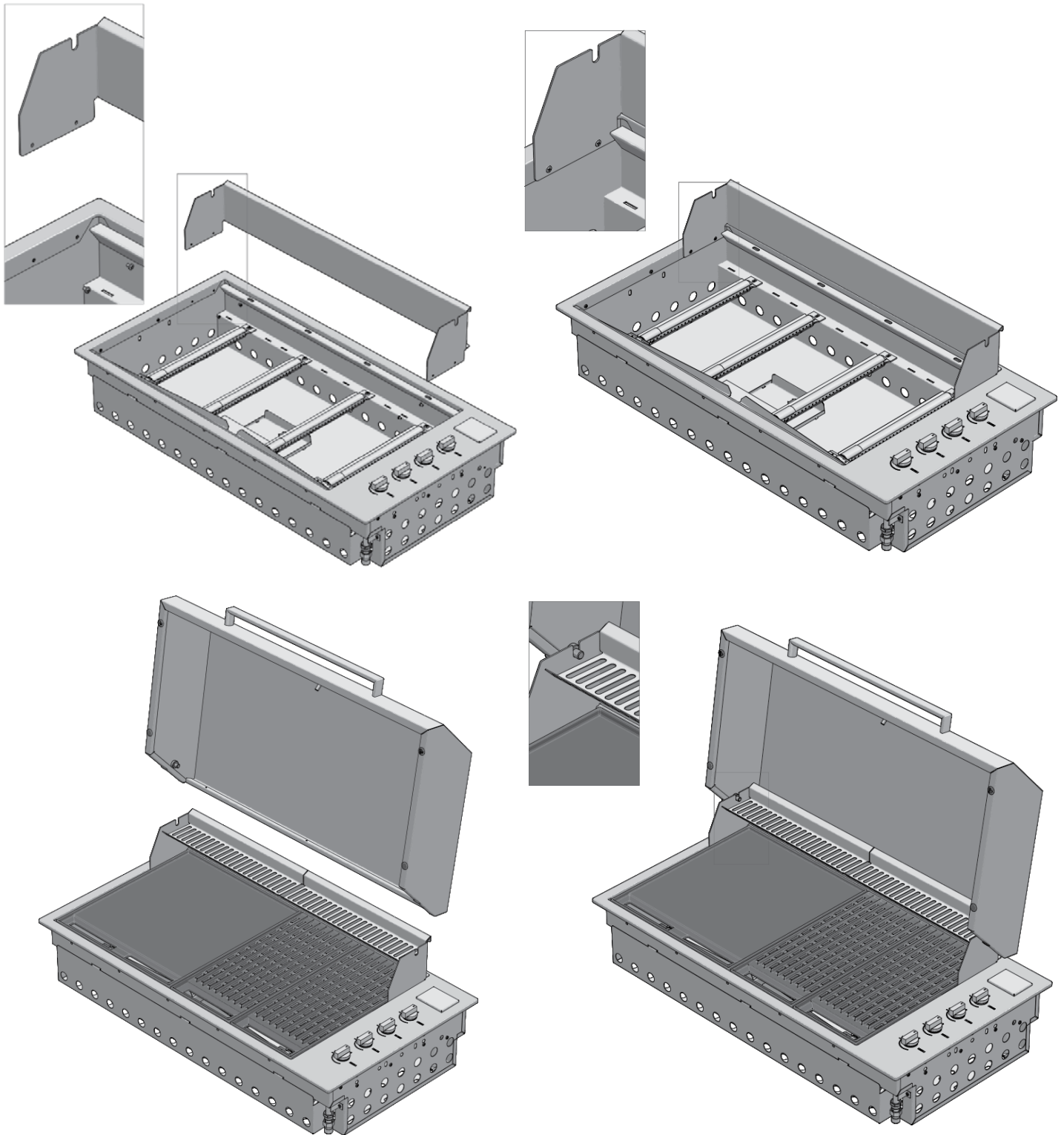

# USAGE INSTRUCTIONS



Make sure that the flame diffusers are positioned flame under the panels of the grills

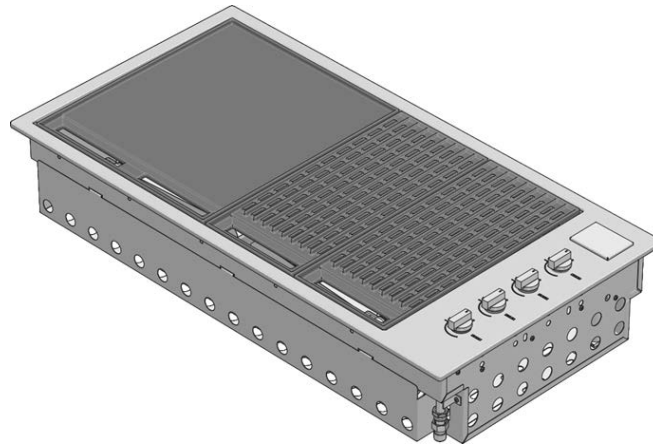

**BBQ 100** Solid cooking plate on the left, double grill on the right - best orientation for grilling

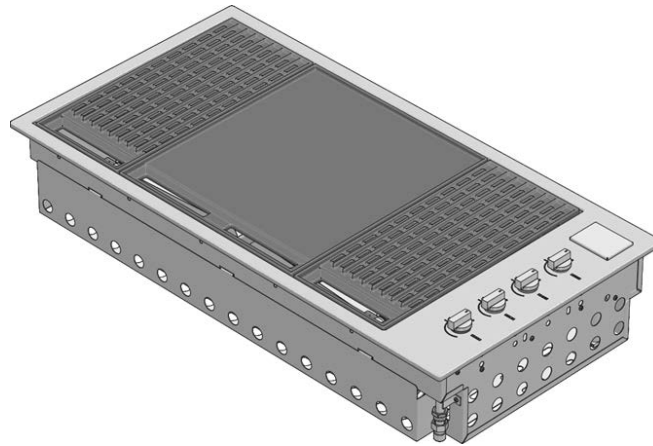

**BBQ 100** half grill on the left, central solid cooking plate, half grill on the right - best orientation for roasting

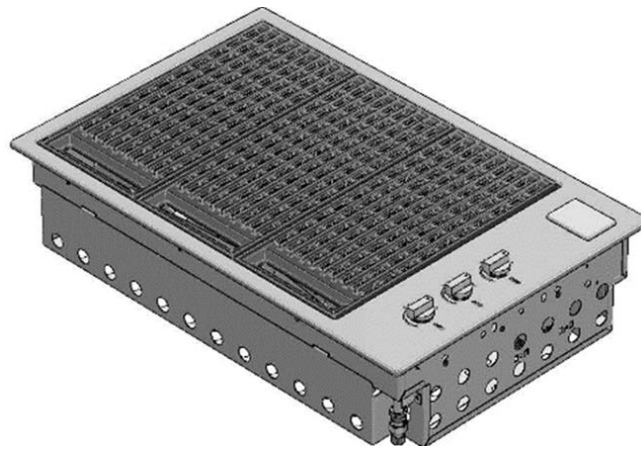

**BBQ 80** total grill

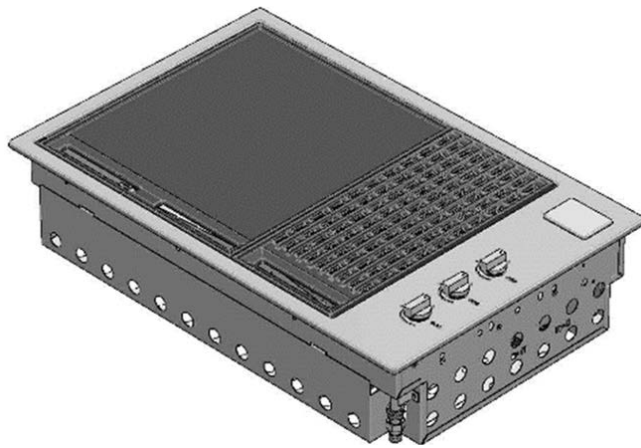

**BBQ 80** Solid cooking plate on the left, grill on the right - best orientation for grilling

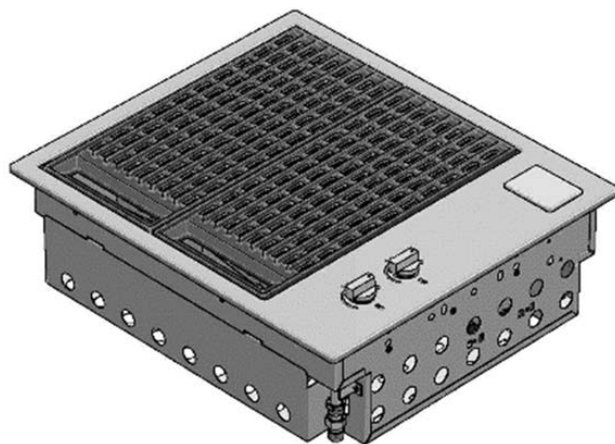

**BBQ 60** total grill

## IGNITING YOUR BBQ

### CONTROL FUNCTIONS

Before lighting the barbecue:

- remove any protective cover **NOTE:** The thin cover is intended to protect. The cover is not intended to be used as a cooking hood.
- Make sure that all the control knobs are in the closed (O) position
- Make sure that the cooking surfaces are clean
- Check that all the gas hoses and fittings are tight.
- Open the main gas valve.
- Open the thin or high cover.

### IGNITION INSTRUCTIONS

- Do not light the burners with the cooking surfaces covered.
- To light a burner, press the knob and turn it to the "MAX" (fast pre-heating) position.
- Hold it for 5 seconds (count to 10), release it and check the flame from the slots in the front. (See page 41)
- If the burner is not lit, turn the knob to the closed (O) position. Allow the gas to disperse, and then repeat the ignition procedure.

- Incorrect lighting of the barbecue can result in serious injury, fire, explosion or death. If the burner does not light, turn the gas off, wait 5 minutes to allow the gas to disperse before attempting to light appliance again.

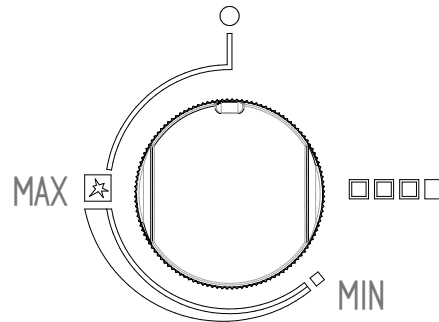

### MANUAL LIGHTING

- If the automatic ignition system is not working, the barbecue can be lit manually.
- To turn it on manually, use a long match (28cm). Pass the lit match between the inspection slots under the front part of the hob, approaching it to the burner, then turn the knob and hold it pressed on MAX (quick preheating) in order to perform the ignition. If it does not light, close the control valve and wait a few minutes for the gas to disperse before trying to light the barbecue again.
- Once one burner is lit, repeat the procedure for the others, if necessary.

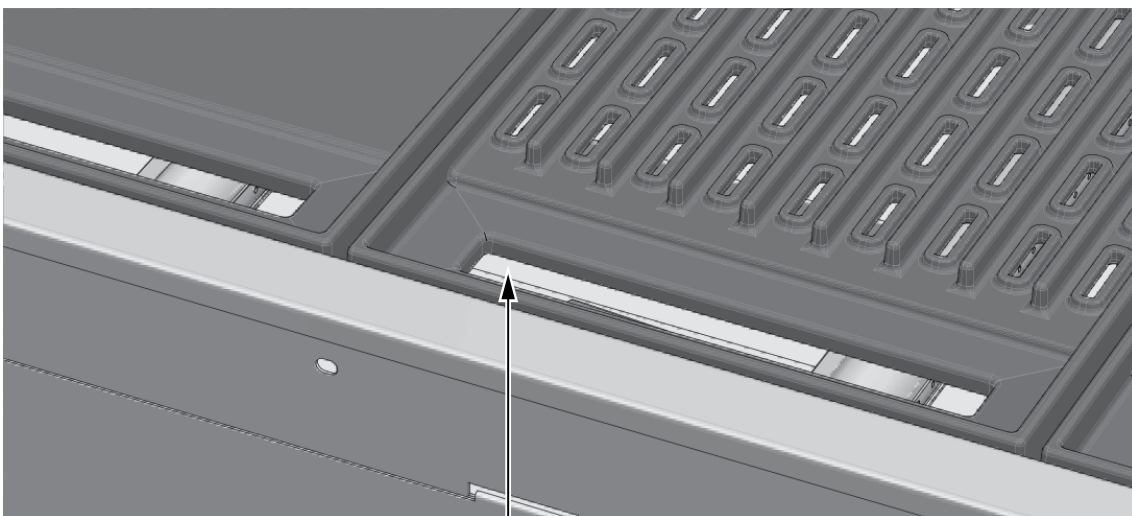

Inspection slits



### PRE-HEATING COOKING AREAS

- The barbecue is equipped with high-power burners. Under most conditions, it will only be necessary to pre-heat the barbecue for just 5 minutes before starting to cook.
- As with most things, experience will teach the user the effectiveness and interval necessary for reaching the best pre-heating time for obtaining the ideal cooking temperature. Don't forget that this also depends on the type of food, its thickness and how you want to cook it.
- Tests have shown that you can reduce the heat of the burners for satisfactory cooking.
- If the barbecue has a thin cover, you should remove it in the presence of wind.
- If the appliance is not working properly, refer to the chapter "Troubleshooting".
- If you let the cooking areas overheat, there will be excessive smoke during cooking and the food will burn.
- While cooking, avoid leaning over the open grill or placing the hands or fingers on the edge of the oven.
- In case of uncontrolled sudden flames, remove the food from the fire until the flame is damped.
- **Outdoor use only** To roast with the high cover closed, it is sufficient to adjust the 4 burners to the minimum power (MIN) for satisfactory cooking

### TO TURN OFF THE BURNER

- When done cooking, turn the knob fully clockwise so that the mark on the knob is in the closed (O) position.



**REMEMBER TO ALWAYS CLOSE THE VALVE OF THE GAS CYLINDER AFTER USE (OUTDOOR USE ONLY).**



**REMEMBER TO SHUT-OFF THE GAS BEFORE CLOSING THE COVER.**

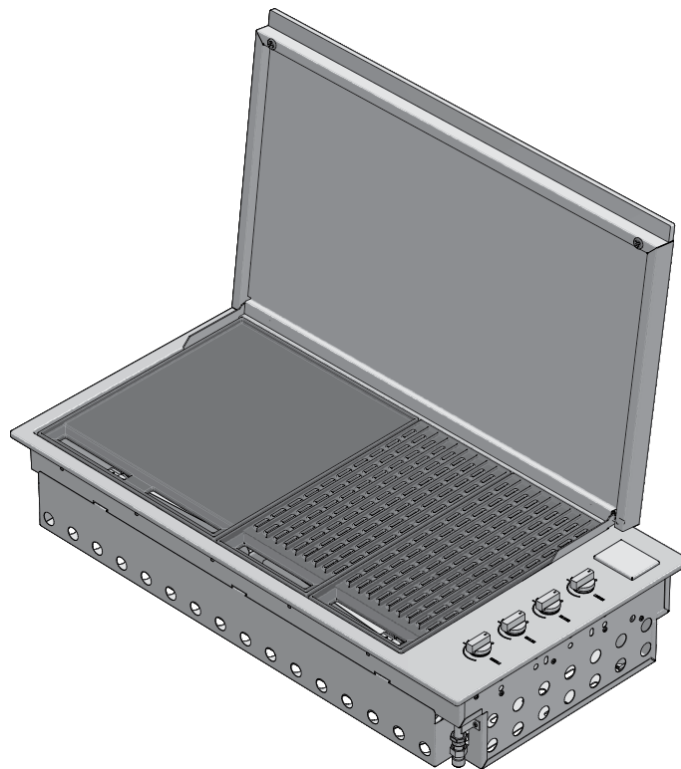

**ATTENTION**

THE COVER MUST NOT BE CLOSED WHEN THE BURNERS ARE LIT

## CLEANING AND CARE

### CLEANING OF COOKING PARTS

- Remove from the grill and from the cooking burners all the solid materials and the excess grease using a scraper or a metal brush with brass bristles
- Use a clean, dry cloth to make sure all surfaces are dry.

### OTHER STAINLESS STEEL SURFACES



#### WARNING

Do not use caustic or abrasive detergents, steel wool or metal scrapers on these stainless steel surfaces because they can scratch and permanently damage the barbecue.

- Wash all stainless steel parts, including the thin cover, high cover and control knobs, with a soft cloth and warm soapy water
- Clean the surfaces, making sure to rub/dry in the direction of the grain in order not to damage the stainless steel.
- The inside of the barbecue can be cleaned with a soft cloth soaked in warm soapy water. The front panel/tray placed inside can be removed for an easy cleaning.
- Use a clean, dry cloth to make sure all surfaces are dry.
- **VERY IMPORTANT!** After drying, finish off the process with 3M™ Stainless Steel Cleaner and Polish or similar product in order to protect the stainless steel surface from corrosion and give it a polished shine.

### CLEANING THE COOKING GRILLS MADE OF CAST IRON

- Clean with an adequate brass bristle brush. If necessary, remove from barbecue, wash with warm soapy water, rinse with water and dry carefully.

**VERY IMPORTANT!** After drying, finish off the process with 3M Stainless Steel Cleaner and polish or similar product in order to protect the stainless steel surface from corrosion and give it a polished shine.

**IMPORTANT:** After cooking and cleaning, the cast-iron grids should be oiled. After drying, finish off the process with 3M Stainless Steel Cleaner and polish or brush. Afterwards, use a cloth to rub the cookware as if you want clean the oil you just placed on it.



#### WARNING

Pay particular attention (especially when cleaning the knobs and around the knobs) to avoid water and soap residue from entering the control panel containing the valves or in the burners. Also, be careful not to touch the ignition electrode and thermocouple. There must be 3 mm of space between the electrode and the burners (see drawing on the next page). If the unit is exposed to the elements we recommend you use the optional vinyl cover.

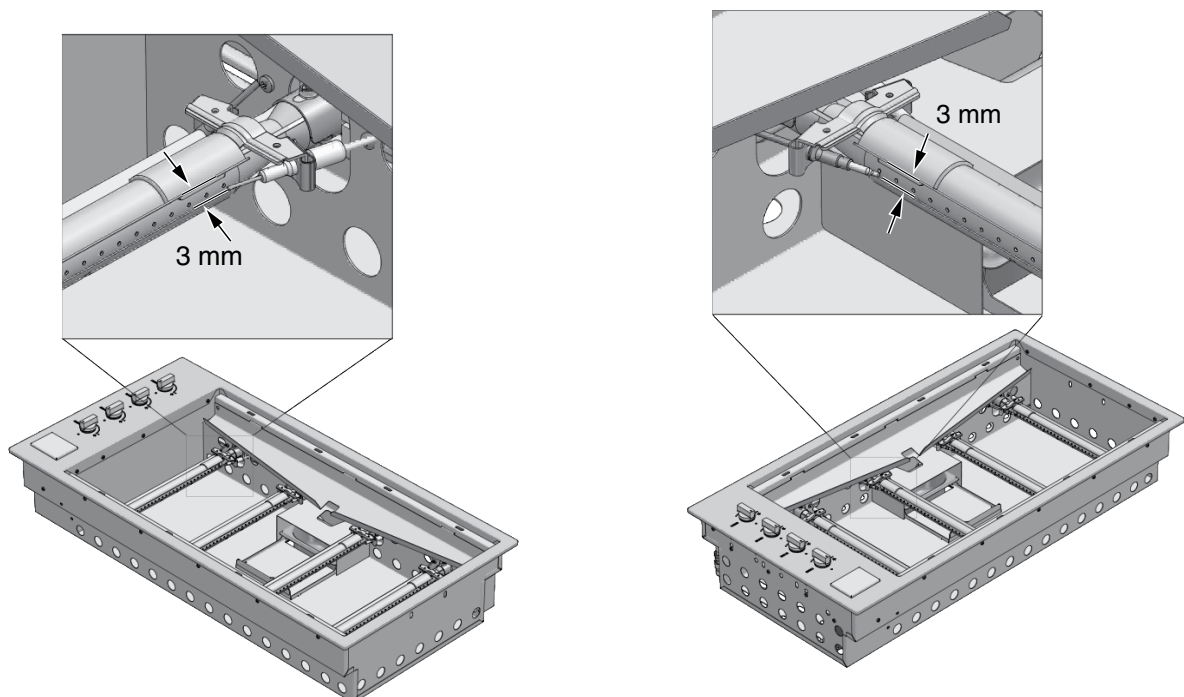

## CLEANING THE GREASE DRIP PAN

The integrated barbecue has a unique oil management system that uses overlapping channels to convey all the oil towards the front to easily removable drip pans, which must be cleaned after each use.

- To remove the drip pan, pull them upwards from the front of the barbecue; dispose of their contents in a responsible way. Wash the collection pans in hot soapy water or, if you want, you can put them in the dishwasher.

1 - To remove the drip pan

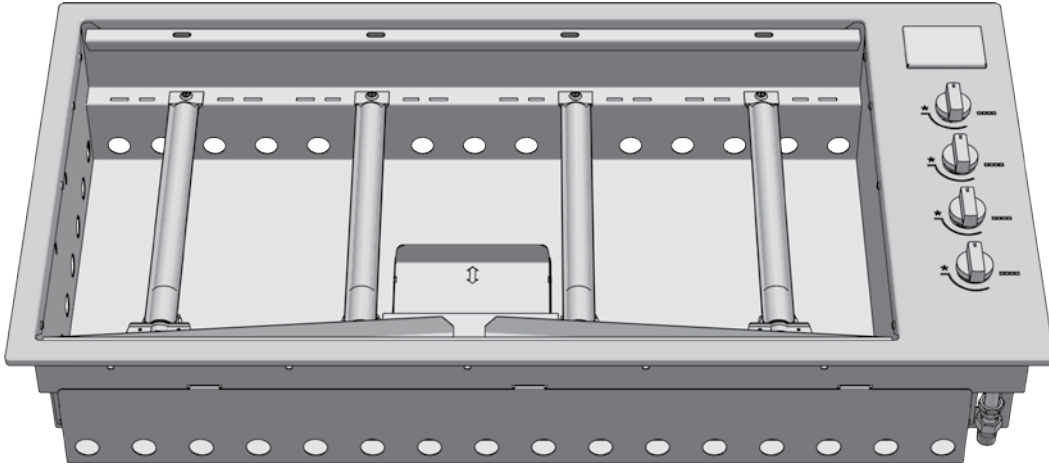

2 - Move the drawer

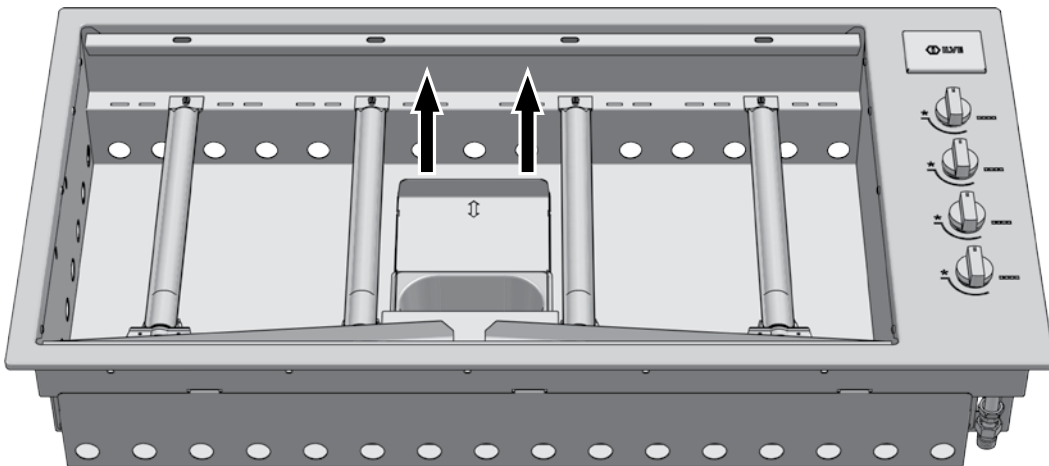

3 - Raise up the pan up

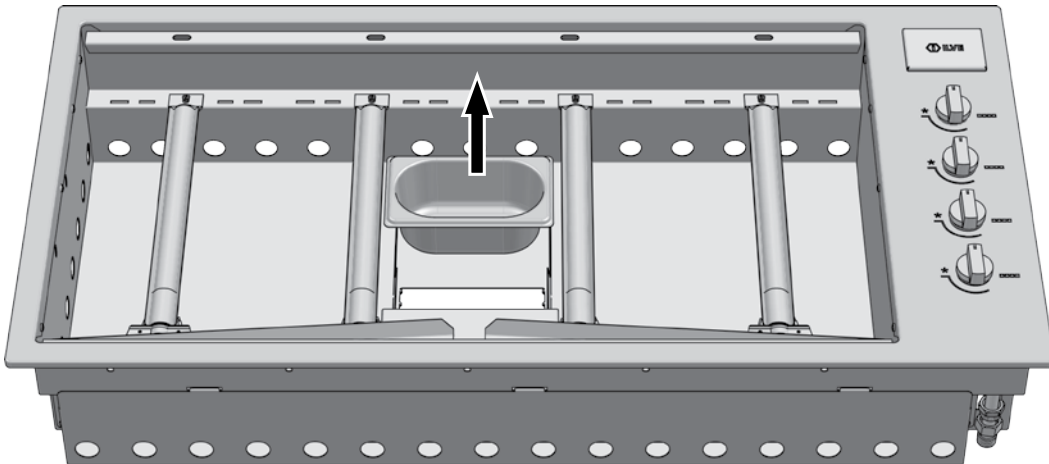

## BURNERS

The burners should be checked at least once a year and cleaned if necessary. Inspect the burners to make sure that no residue deposits and that the gas connections are free.

## MAINTENANCE

### IGNITION SYSTEM

To change the battery, remove the battery cover by lifting the battery holder flap on the left side and pull out the battery. Replace it with a new D battery and replace the cover. Perform a test by pressing the knob; you should hear a click.

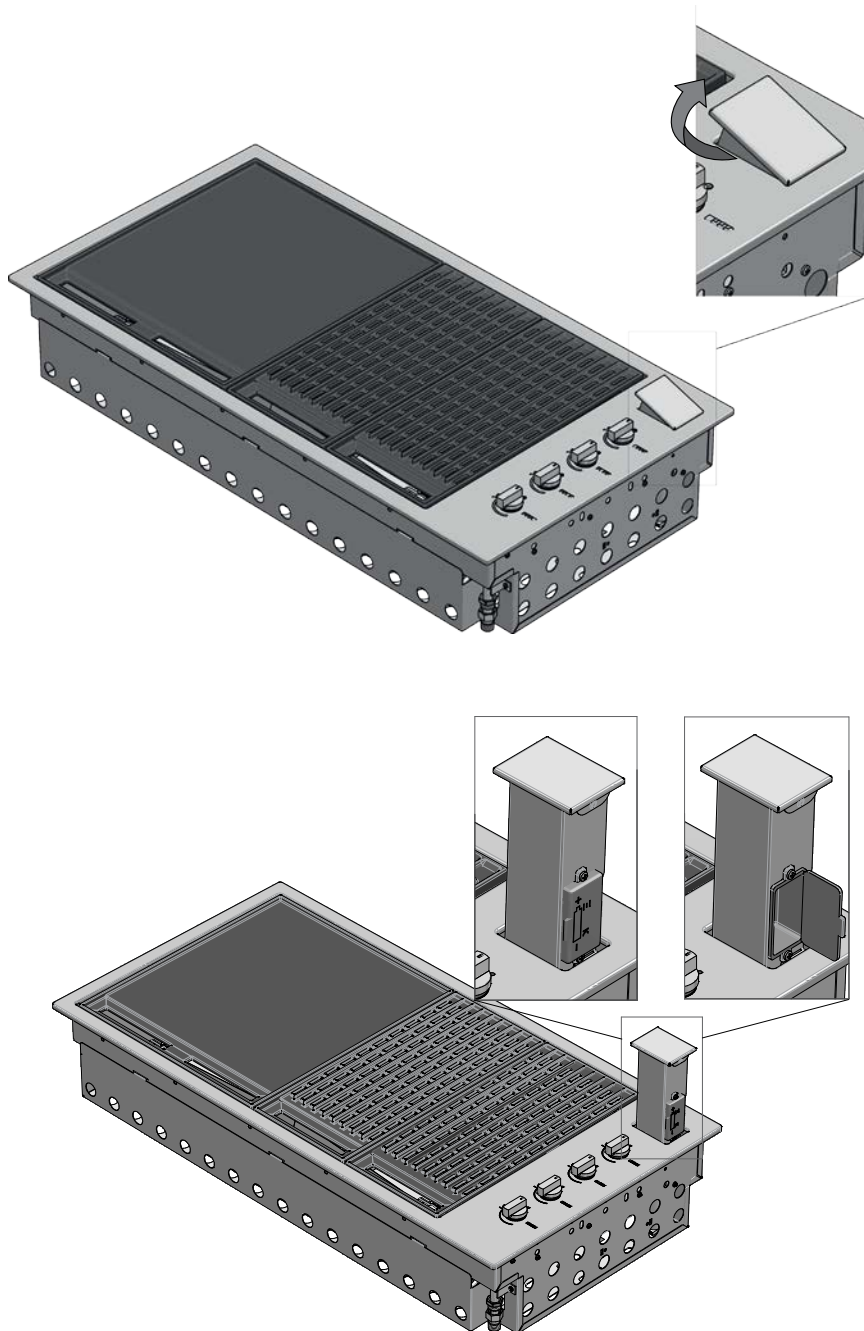

### Ventilation openings

The ventilation openings of the installation compartment must be inspected before each use of the appliance to make sure that there are no obstructions that could impede the free flow of air.



### SUGGESTIONS AND INFORMATION

#### SPECIAL NOTE ON "TEA STAINING"

Sometimes stainless steel surfaces are affected by a colour change called "tea staining".

This usually occurs in areas where high heat is used and can be removed using stainless steel cleaning agents. For best results, we recommend that you regularly use stainless steel cleaner on all stainless steel parts. These cleaners are available in all hardware stores and supermarkets.

#### SPECIAL NOTE ON STAINLESS STEEL

Stainless steel panels can be deformed during use but return to their normal shape when cooled.

# TROUBLESHOOTING

PROBLEM	POSSIBLE CAUSE	SOLUTION
The barbecue doesn't light	No gas	Check that the shut-off valve is open (ON)
		Gas cylinder empty - refill or change the cylinder
	The ignition system is not working	Check the battery - you should hear a clicking sound when you press the knob
		Replace the battery
	Light the barbecue manually	
	Gas tap regulated too high	Clean and delicately dry the electrode making sure that its position is correct
Excessive smoke from the cooking surface	Gas valve set too high	Lower the gas or turn off some of the burners
Odour of gas DON NOT TRY TO LIGHT THE APPLIANCE	Gas leak	Close the gas with the shut-off valves
		Check for leaks, tighten the fittings
		If the problem persists, call the Service Centre

Annual service by an authorised person is recommended, or if any of the following conditions are noticed; incomplete ignition, appreciable yellow tipping, carbon deposition, lifting, floating, lighting back or objectionable odour.

## CUSTOMER CARE

For service please contact us at [customercare@eurolinx.com.au](mailto:customercare@eurolinx.com.au) or 1300 856 411 **option 1**



#### **MANUFACTURER'S DECLARATION**

The manufacturer declares that, depending on their type, the products in this catalogue conform to the fundamental requirements of European Directives and, for this reason, the product bears the CE mark, for which this declaration of conformity was issued and made available to market supervisory bodies.

#### **DISPOSAL OF USED APPLIANCES**

At the end of their useful life, these appliances may not be disposed of with normal urban waste but must be given to an electronic and electrical equipment collection and recycling point. This is indicated by the symbol shown on the product, in the instruction manual or on the packing materials. The materials used in this appliance can be reused in conformity with their intended use. Thanks to the reuse, recycling or other forms of recovery of unusable appliances, you will make a contribution to protecting our natural environment. You can obtain information about the disposal points for unusable appliances from your local authorities.



The manufacturer will not be liable for inaccuracies in this manual due to typographic errors. We reserve the right to make improvements or indispensable modifications to products without altering their essential specifications. Products can be modified following requests for improvements and CE standards.

# Warranty Card

artusi.com.au

**Worldwide Appliances Pty Limited**  
**A.B.N. 45868077422**

**Distributed by Eurolinx Pty Ltd**

**Office:**

**48-50 Moore Street, Leichhardt N.S.W 2040**

**Post:**

**Locked Bag 3000, Annandale, N.S.W 2038**

**P: 1300 694 583**

## **WARRANTY REGISTRATION**

Your ongoing satisfaction with your artusi product is important to us. We ask that you complete the enclosed Warranty Registration Card and return it to us so that we have a record of the artusi product purchased by you.

## **PRIVACY**

Worldwide Appliances respects your privacy and is committed to handling your personal information in accordance with the National Privacy Principles and the Privacy Act 1988 (Cth). A copy of the Worldwide Appliances Privacy Policy is available at [www.artusi.com.au](http://www.artusi.com.au). Worldwide Appliances will not disclose any personal information set out in the Warranty Registration Card ("Personal Information") without your consent unless required by:

1. law;
2. any Worldwide Appliances related company;
3. any service provider which provide services to artusi or assist artusi in providing services (including repair and warranty services) to customers. Our purpose in collecting the Personal Information is

to keep a record of the artusi product purchased by you, in order to provide a better warranty service to you in the unlikely event that there is a problem with your artusi product. Worldwide Appliances may contact you at any one or more of the address, email address or telephone numbers set out in the Warranty Registration Card. Please contact artusi on 1300 694 583 should you not wish to be contacted by Worldwide Appliances.

## **WARRANTY**

### **1. Warranty**

Worldwide Appliances warrants that each artusi product will remain, for a period of either 12 months or 24 months of warranty. All Warranties are valid from the original date of purchase, And warranty claims must be accompanied by the proof of purchase.

### **24 months warranty products:**

All Built-in Appliances – Limited to Ovens, Gas, Induction and Electric Cooktops, and All Rangehoods. Freestanding Cookers - Gas and Electric Models (900mm Width).

Dishwashers - Freestanding, Fully Integrated, Semi Integrated and built-in. All Wine coolers. All Dryers. Freestanding Cookers - Gas and Electric Models in 50cm, 54cm and 60cm Widths  
Portable Appliances\* – Benchtop Models and Portable Gas Models

### **2. What is not Covered by the Warranty.**

The Warranty does not apply if an artusi product is defective by a factor other than a defect arising in the manufacture of the artusi product, including but not limited to:

- (a) damage through misuse (including failure to maintain, service or use with proper care), neglect, accident or ordinary wear and tear (including deterioration of parts and accessories and glass breakage);
  - (b) use for purpose for which the artusi product was not sold or designed;
  - (c) use or installation which is not in accordance with any specified instructions for use or installation;
  - (d) use or operation after a defect has occurred or been discovered;
  - (e) damage through freight, transportation or handling in transit (other than when Worldwide Appliances is responsible);
  - (f) damage through exposure to chemicals, dusts, residues, excessive voltage, heat, atmospheric conditions or other forces or environmental factors outside the control of Worldwide Appliances;
  - (g) repair, modification or tampering by the purchaser or any person other than Worldwide Appliances, an employee of Worldwide Appliances or an authorised artusi service contractor\*;
  - (h) use of parts, components or accessories which have not been supplied or specifically approved by artusi.
  - (i) damage to surface coatings caused by cleaning or maintenance using products not recommended in the artusi product handbook provided to the purchaser upon purchase of the artusi product;
  - (j) damage to the base of an electric oven due to items having been placed on the base of the oven cavity or covering the base, such as aluminium foil (this impedes the transfer of heat from the element to the oven cavity and can result in irreparable damage); or
  - (k) damages, dents or other cosmetic imperfections not affecting the performance of the artusi in respect of an artusi product purchased as a "factory second" or from display
- The Warranty does not extend to light globes used in artusi products.

### **3. Domestic Use**

Each artusi product is made for domestic use. This Warranty may not extend to artusi products used for commercial purposes.

***Continued over...***

## 4. Time for Claim under the Warranty

You must make any claim under this Warranty within twenty eight (28) days after the occurrence of an event which gives rise to a claim pursuant to the Warranty, by booking a service call on the telephone number below.

## 5. Proof of Purchase

Customers must retain proof of purchase in order to be eligible to make a warranty claim in respect of an artusi product.

## 6. Claiming under the Warranty

Customers will bear the cost of claiming under this Warranty unless Worldwide Appliances determines the expenses are reasonable, in which case the customer must claim those expenses by providing written evidence of each expense to Worldwide Appliances at the address on the Warranty Registration Card.

## 7. Statutory Rights

(a) These terms and conditions do not affect your statutory rights.

(b) The limitations on the Warranty set out in this document do not exclude or limit the application of the consumer guarantees set out in the Act or any other equivalent or corresponding legislation in the relevant jurisdiction where to do so would:

(i) contravene the law of the relevant jurisdiction; or

(ii) cause any part of the Warranty to be void.

(c) Worldwide Appliances excludes indirect or consequential loss of any kind (including, without limitation, loss of use of the artusi product) and (other than expressly provided for in these terms and conditions) subject to all terms, conditions and warranties implied by custom, the general law, the Act or other statute.

(d) The liability of Worldwide Appliances to you

for a breach of any express or non-excludable implied term, condition or warranty is limited at the option of Worldwide Appliances to:

(i) replacing or repairing the defective part of the artusi product;

(ii) paying the cost of replacing or repairing the defective part of the artusi product;

(iii) replacing the artusi product; or

(iv) paying the cost of replacing the artusi product.

(e) Our goods come with guarantees that cannot be excluded under the Australian Consumer Law. You are entitled to a replacement or refund for a major failure and for compensation for any other reasonably foreseeable loss or damage. You are also entitled to have the goods repaired or replaced if the goods fail to be of acceptable quality and the failure does not amount to a major failure.

## 8. Defects

Any part of an artusi product deemed to be defective and replaced by Worldwide Appliances is the property of Worldwide Appliances. Worldwide Appliances reserves the right to inspect and test artusi products in order to determine the extent of any defect and the validity of a claim under the Warranty.

**All warranty service calls must be booked via the customer care department. The team can be contacted on 1 300 85 64 11 option 1 or [customercare@eurolinx.com.au](mailto:customercare@eurolinx.com.au)**

**01082016**

**DON'T FORGET TO REGISTER  
YOUR WARRANTY ONLINE  
NOW AT [www.eurolinx.support](http://www.eurolinx.support)**



**TO REGISTER  
YOUR WARRANTY**







**FOLLOW US ON:**

 [instagram.com/artusi\\_appliances](https://www.instagram.com/artusi_appliances)

 [www.linkedin.com/company/eurolinx-pty-ltd-t-a-ilve/](https://www.linkedin.com/company/eurolinx-pty-ltd-t-a-ilve/)

---

**Australia National Telephone Number 1300 (694 583) New Zealand Telephone Number 64 3 344 5913**  
**Artusi showroom hours:** Tuesday to Friday - 9am-5pm, Saturday - 10am-4pm, Sunday and Monday - closed  
**\* Melbourne showroom hours:** Tuesday to Saturday - 10am-4pm

[artusi.com.au](https://www.artusi.com.au)

---

**NSW & ACT (Head Office)**  
48-50 Moore Street  
Leichhardt  
F 02 8569 4699

**VIC**  
2r/131 Church St,  
Hawthorn

**QLD**  
1/42 Cavendish Road  
Coorparoo  
F 07 3397 0850

**WA & NT**  
Unit 10/55 Howe Street  
Osborne Park  
F 08 9201 9188

**New Zealand**  
PO Box 11.160  
Sockburn Christchurch  
F 03 344 5906