



Tricel[®] Vento

Septic Tanks

Engineering a green future



Table of Contents

1. Health and safety precautions.....	3
2. Transportation, Offloading and storage:	3
3. The wastewater purification process:.....	4
4. Tank dimensions.....	5
5. Tank drawings:	6
6. Lid Security:.....	7
7. Manhole risers – (deep inverts):.....	8
8. Installation.....	9
8.1 Pre-Installation Inspection	9
8.2 Quick installation guidelines:	9
8.3 Detailed installation information	11
8.4 Gravel installation:	13
8.5 Concrete installation:	14
8.6 Plinth and backfill specifications:	16
9. Plumbing the system	18
9.1 Treatment of effluent liquid:	18
9.3 Ventilation:	19
10. Maintenance.....	19
10.1 Quarterly Maintenance (3 months):	19
10.2 Yearly maintenance:	19
11. Operating conditions:.....	20

It is important to read the full technical and installation guide prior to installation. This document should be retained for the lifetime of the product and in the event of change of ownership be transferred to the new owner.

Precaution

Prior to installation, please consider finished garden level when installing the system. If you envisage that a manhole riser/extension may be required to ensure manhole lid remains above finished ground level, the system must be installed with the appropriate excavation foundation and backfill to accommodate the riser. Please refer to page 5 for manhole riser details.



Certified to EN 12566-1

1. Health and safety precautions

As safety and security are of vital importance in septic tank installation, the following aspects are critical.

- Ensure that all the information contained in this manual is adhered to at all times
- Because of working with machinery and electrical equipment, proximity of water shall be noted.
- There is potential danger when de-sludging and therefore this shall never be done alone.
- Never enter a tank unless qualified to do so.
- Naked flames shall not be used in the vicinity of the tank due to the danger of combustion.
- The manhole cover shall never be left off an unattended tank.
- Protective clothing / gloves shall be worn at all times. Always remove contaminated clothing and protective equipment after working with septic tank.
- Wash hands and face prior to eating, drinking or smoking.
- A second person shall be present when carrying out maintenance.
- A sampling box should be constructed if required to facilitate sampling and inspection without placing personnel at risk.
- Great care shall be taken when handling sludge.
- Always secure the cover of the system when maintenance is completed.
- Lids are not designed to be walked on.

2. Transportation, Offloading and storage:

1. Tanks must be held down during transportation using nylon straps, do not use cables or chains to secure tanks. Do not over tighten straps to cause deformation of the tank shell
2. Always set the tank(s) on flat smooth ground free from debris etc. To prevent movement, tanks may need to be tied down.
3. Tanks are best lifted by crane or suitable lifting equipment and webbing lifting straps – do not use chains or wire ropes in contact with the tank. Ensure tank is empty when lifting.
4. Move tanks only by lifting and setting, do not push or drag
5. Do not drop or push tanks from truck/trailer.

3. The wastewater purification process:



The Tricel Vento septic tank is an ideal solution for wastewater treatment when used in conjunction with the appropriate disposal system.

The tank is sized sufficiently to hold wastewater for an adequate amount of time for the solids to drop to the bottom to form a sludge and the lighter material to rise to the top of the liquid to form a scum. The remaining liquid effluent is passed through the outlet pipe into the disposal system for final treatment.

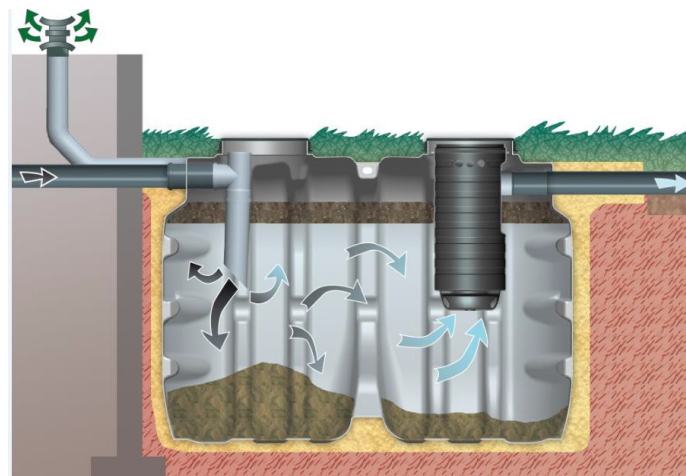

4. Tank dimensions

Tank Name		Vento 6	Vento 12	Vento 20
Max design population	Pop	6	12	20
Tank capacity (actual)	litre	3056	4255	5008
Nominal inlet/outlet pipe diameter	mm	110	110	110
Overall length	mm	2700	2040	2430
Overall width	mm	1190	1850	1850
Overall height	mm	1440	1540	1540
Inlet invert to base	mm	1180	1220	1220
Outlet invert to base	mm	1150	1190	1190
Inlet invert to ground level – tank only	mm	185	245	245
Inlet invert to ground level – with 1 riser*	mm	365	425	425
Outlet invert to ground level-tank only	mm	215	275	275
Height above ground level	mm	75	75	75
Weight empty	mm	119	140	160

Note: Due to the manufacturing process there may be slight variances in these dimensions. Please check your individual unit prior to installation.

5. Tank drawings:

Vento 6

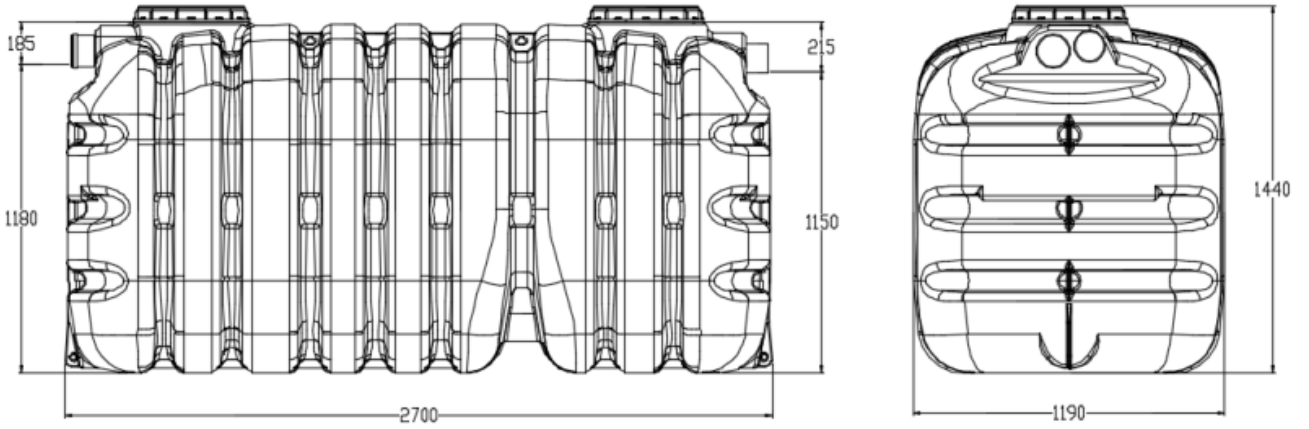

Vento 13

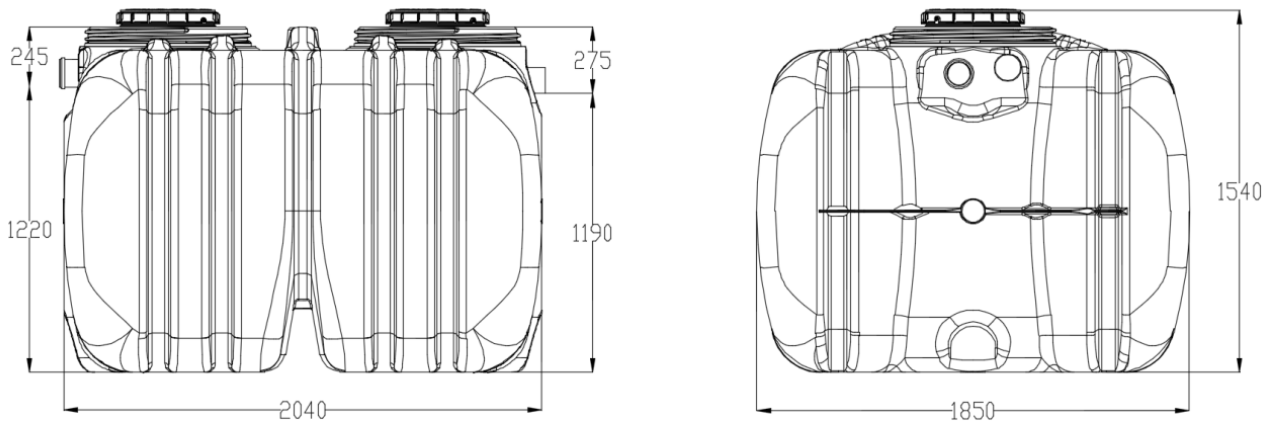

Vento 20

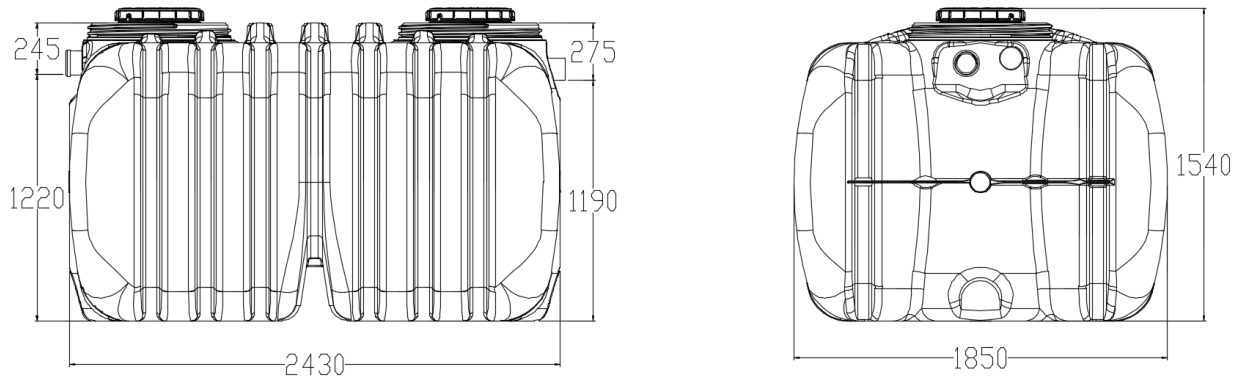

6. Lid Security:

Each lid should be secured at all times to prevent unauthorised access. Tanks are supplied with two securing points, as shown below.

To secure lid, rotate until tight. Tighten screw in place with screwdriver. Lid is now secured in place.



7. Manhole risers – (deep inverts):

Manhole risers are available for deeper installation requirements. They are available in 180mm increments x 400mm diameter to a maximum height of 540mm (max 3 risers).



All manholes lids are securable and must be secured for safety and to prevent unauthorised access. All maintenance work is done through these manholes.

- Never install the cover of the system under ground level.
- Do not allow ground water to enter the system.
- Only Tricel Vento manhole risers shall be used.

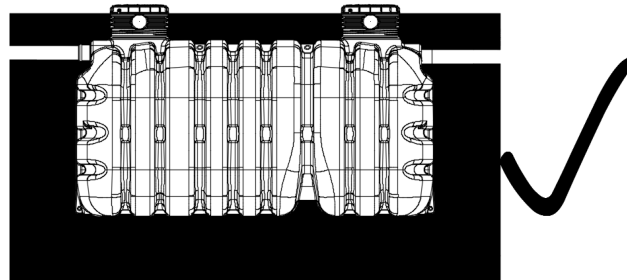
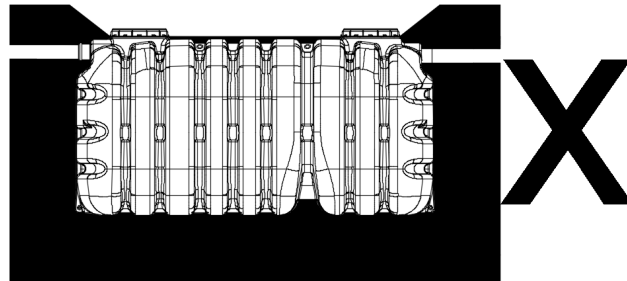

8. Installation

All installations must be “fit for purpose” to suit the on-site conditions, which will vary from site to site. This is the responsibility of the onsite contractor. This gives maximum outlet invert level to ground level of 755 mm for the Vento 6 and 815 mm for the Vento 13 and Vento 20. The Tricel Vento is not suitable where a deeper installation is required.

8.1 Pre-Installation Inspection

- Tanks should be subject to visual inspection prior to installation
- Check for, fractures to the shell or ribs, deformation, punctures, scratches or abrasions deeper than 1.5mm
- Any damage should be notified to the delivery driver and/or to your supplier
- Do not attempt to carry out any un-authorised repairs, as this will invalidate the warranty on the tank
- Once the tank has been installed, we cannot accept any claims for damage.

8.2 Quick installation guidelines:

A **dry** site is one where the water table never rises higher than the base of the Tricel Vento unit and the surrounding ground is free draining.

A **wet** site is one where the water table may rise higher than the base of the Tricel Vento unit or the surrounding soil is not free draining. The unit should never be installed where ground water can rise higher than the outlet pipe.

Guidelines	Dry Site	Wet Site
All installations must be “Fit for purpose” to suit the on-site conditions, which will vary from site to site. This is the responsibility of the onsite contractor.	✓	✓
Never push the tanks. Tanks shall be lifted into position.	✓	✓
The unit should be located as far away from the dwelling as is practically possible considering topography and pipe work levels. Separation distances must meet all National and Local regulations	✓	✓
Dig a hole circa 400mm larger than the system in plan.	✓	✓

Remove any soft spots or boulders of significant size from the base or sides of the excavation	✓	✓
Ground water must be pumped to give a dry excavation and excavation lined with polythene if necessary		✓
A base is then formed using 200mm of gravel (suitable to site conditions) and this must be flat and level.	✓	
A base is constructed of a 300mm layer of dry mix to suit site conditions. This must be flat and level.		✓
Ensure gravel/dry mix are clean and contains no large materials	✓	✓
Lift tank into position and align as required for connecting pipe work, access shafts etc.	✓	✓
Ensure that each tank is 100% level, and that inlet/outlets are in the correct orientations.	✓	✓
Secure anchor straps if required.	✓	✓
Fill tank with water at the same rate as you backfill the tank.	✓	✓
Mount and seal risers	✓	✓
Commence gravel backfilling in 300mm layers to 100mm over the tank, ensuring tank and any pipe work is properly supported.	✓	
Commence backfilling in 300mm layers to 100mm over the tank, ensuring tank and any pipe work is properly supported.		✓
Minimal compaction should be used on the surrounding backfill.		✓
Complete backfilling with topsoil up to ground level. Ensure that surrounding finished ground level is never higher than the cover of the tank.	✓	✓
Compact evenly around the riser extensions to reduce risk of distortion.	✓	✓
Ensure that No surface loadings are transferred from the cover direct to the tank. Cover frame construction should allow movement.	✓	✓
An access chamber should be installed before and after the tank to assist in clearing possible blockages	✓	✓
If sewage consists of high quantities of grease e.g. from a restaurant, a grease trap may have to be installed on a separate drain prior to the system.	✓	✓

8.3 Detailed installation information

8.3.1 Sitting

The minimum set back distances for installing the septic tank are outlined below:

	Ireland	England/Wales	Scotland	Northern Ireland
Any Dwelling	7 meters	7 meters	5 meters	7 metres
Boundary	3 meters	5 meters	5 meters	5 meters
Wall/building	4 meters	4 meters	4 meters	4 meters
Hedge or tree roots	3 meters	5 meters	5 meters	5 meters

The minimum set back distances for soak away/percolation area are outlined in the table below:

	Ireland	England/Wales*	Scotland	Northern Ireland
Any Dwelling	10 meters	15 meters	5 meters	7 meters
Hedge or tree roots	3 meters	5 meters	5 meters	5 meters
Well, borehole or spring	Depends on site conditions	50 meters	50 meters	50 meters
Watercourse	10meters	10 meters	10 meters	10 meters
Lake	50 meters			

*Drainage field should be separate from any other water supply pipes or other underground services and clear of any access roads, driveways, or paved areas.

The Tricel Vento should not be installed in an area subject to flooding or excessive water runoff. The area around the Tricel Vento should be adequately drained, to permanently remove water from the proximity of the tank. The Tricel Vento system is not suitable to be used in water logged sites, where the water level may rise above the outlet level.

8.3.2 Control of groundwater:

During installation tanks must not be subjected to buoyant forces. Incorrectly installed tanks that are subject to movement, rotation or floatation may become damaged, for which we cannot accept liability. Contact a qualified engineer if there are difficulties on site due to adverse water logging.

8.3.3 Note: water logged sites:

The Tricel Vento septic tank is not suitable to be used in water logged sites, where the ground water may rise above the outlet level. Adequate drainage is important to improve wet sites, or sites with a high-water table level. It is recommended that water is removed from the area surrounding the system to prevent flotation. Excessive loading caused by site water can harm the system, please consult with the manufacturer or a qualified engineer if in doubt.

8.3.4 Excavation size:

Suitably sized equipment will be required to excavate the hole and to lift the system into place. Installation depends on on-site conditions, water, slopes, location etc. Excavation should be planned with due regard to Health and Safety requirements, and should be either battered or shored back to a "safe" angle. The excavation should allow a minimum 200mm clearance between the tank and the excavation wall or face of shoring. . Unstable ground with excessive sand, peat swamps etc. may require larger excavations. The excavation should be maintained dry by pumping or whatever suitable means.

External dimensions: Width in meters x Length in meters

Total excavation: {Tank Width + 400mm} x {Tank Length + 400mm} Excavation depth: Allow 200mm for a tank base/plinth on dry site and 300mm for a tank base/plinth on a wet site.

8.3.5 Excavation depth:

The excavation depth is determined by the inlet pipe invert

- The inlet pipe invert level relative to the bottom of the tank (allowing for the minimum base thickness shown in Figure 1.0)
- Tank dimensions shown in section 5
- Ground conditions at foundation level (e.g. running sand may require extra excavation and stabilisation with hardcore or blinding concrete)

Figure 1.

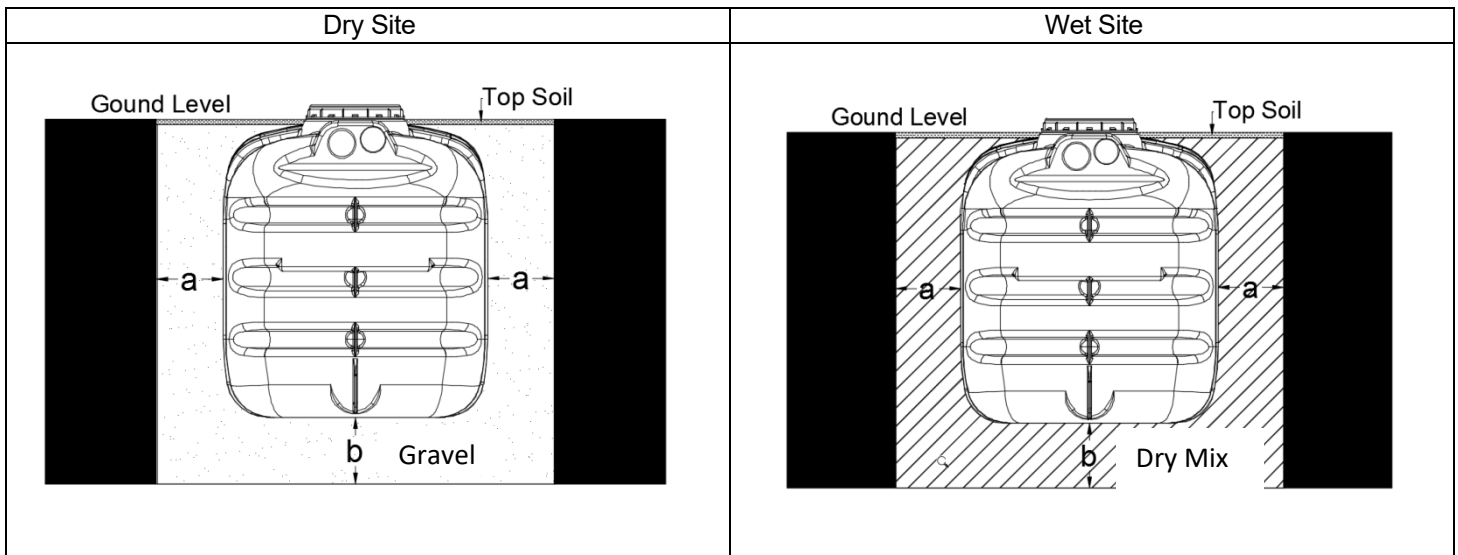

Table 1.0

Site Conditions	"a" minimum in mm	"b" minimum in mm
Dry	200	200
Wet	200	300

8.4 Gravel installation:

A gravel surround can be used in dry site conditions.

A **dry site** is one where the water table never rises higher than the base of the Tricel Vento unit.

8.4.1 Tank base/plinth:

- Remove any soft spots or large stones and boulders
- The base is constructed of a 200mm layer of gravel.
- Ensure that base is level and at the correct height to accommodate the incoming pipe work

8.4.2 Installing onto the base/plinth:

- Mechanically lift the plant carefully into the centre of the hole and place on the prepared plinth
- The plant must sit dead level on the plinth

- Connect and seal the pipe work to the tank.
- Mount and seal manhole risers (if required)

8.4.3 Backfilling dry site

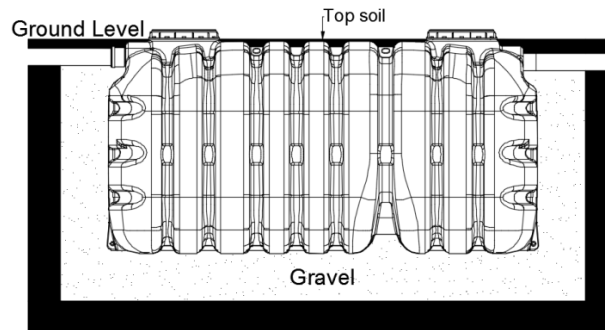

- Fill the plant with clean water to a depth of 300mm and recheck the pipe work levels. Commence backfilling with gravel as per backfill specification in section 7.6.2 in layers of 225mm evenly around the tank ensuring that there are no voids. Compact each layer ensuring the vibrating machine does not come in contact with the plant. Continue filling the chamber with clean water whilst backfilling, ensure that the progressive water level is no more than 300mm above the backfill level.
- Continue to backfill until gravel has reached the inlet pipe level.
- Complete backfilling with topsoil up to the max ground level line.

8.5 Concrete installation:

A concrete surround must be installed in wet site conditions. Concrete to be used is a dry mix spec, see section 7.6.1.

*A **wet site** is one where the water table may rise higher than the base of the Tricel Vento unit or where the surrounding soil is not free draining.*

8.5.1 Tank base/plinth

- Remove any soft spots or large stones and boulders.
- The base is constructed of a 300mm layer of dry mix. Refer to plinth and backfill specifications in section 8.6.
- Ensure that the base is level and ensure that correct orientations are determined to accommodate the incoming pipe work.
- It is important that no excess ground water enters the excavated hole until the concrete is

set. It may be necessary to line the excavation with a continuous layer of 1200 gauge polythene to maintain the integrity of the dry mix.

8.5.2 Installing onto the base/plinth:

- Mechanically lift the plant carefully into the centre of the hole.
- The plant must be dead level on the plinth
- Connect and seal the pipe work to the tank appropriately.
- Mount and seal manhole risers (if required)

8.5.3 Backfilling a wet site:

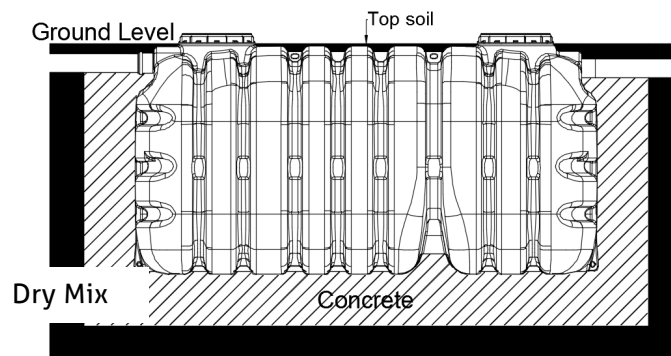

- Fill the plant with clean water to a depth of 300mm and recheck the pipe work levels. Commence backfilling with dry mix as per backfill specifications section 7.6.1 evenly around the tank ensuring that there are no voids. Continue filling the chamber with clean water whilst backfilling, ensure that the progressive water level is no more than 300mm above the backfill level.
- Continue backfilling with dry mix as per plinth and backfill specifications section 8.6 until dry mix has reached the inlet level.
- Complete backfilling with topsoil up to the max ground level line.

8.6 Plinth and backfill specifications:

8.6.1 Dry mix backfill specification:

Dry mix concrete is specified 200kg cement mixed with 1m³ sand.

Note: Standard concrete mixes should not be used, where sulphates or similar aggressive chemicals are present in the groundwater.

Lift height (rate of rise):

Determine the lift height (m), or rate of rise (m/h) for the specific concrete type used, to ensure that a design pressure (P max) of 15kN/m² on the tank is not exceeded.

Vibration:

The design of the tank assumes minimal compaction of the surrounding concrete. Where necessary, this may be extended to include light internal vibration. Never use deep reverberation which will substantially increase the pressure on the tank, possibly causing failure.

Impact of dry mix on discharge:

Under no circumstances should dry mix be discharged directly onto the tank.

8.6.2 Gravel backfill specification:

Primary Backfill material should be free-flowing granular material. The design of the tank assumes minimal compaction of the surrounding concrete. Compact evenly, around the turret extensions to reduce risk of distortion. Tanks must be installed with primary backfill only within the region immediately surrounding the tanks. This primary backfill must extend a minimum of 200mm outward from the tank and directly beneath the tank. The following materials are approved as Primary Backfill:

Rounded pea gravel:

Minimum particle size 3mm, maximum 18 mm, compacted to a relative density of >70%. Gravel shall be clean and free flowing, free from large rocks, dirt, sand, roots, organic materials or debris. Upon screening analysis the backfill material shall have no more than 5% by weight passing 2.36 mm sieve.

Crushed or processed stone:

Minimum particle size 3 mm, maximum 12 mm, compacted to a relative density of >40% Dry gravel density must be at least 1500 kg/m³. Material should be washed or screened to remove fine particles. Upon screening analysis the backfill material shall have no more than 5% by weight passing 2.36 mm Sieve. Use of other than specified backfill and bedding materials will void the tank warranty. Backfill material shall not be frozen or contain lumps of frozen material at any time during placement.

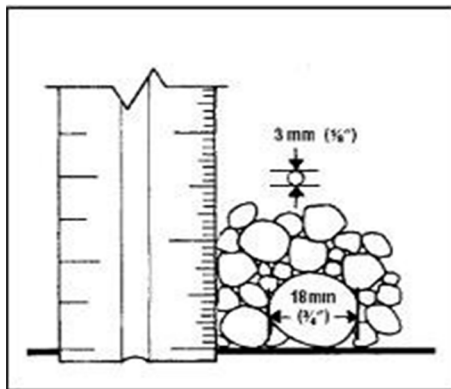

Pea gravel

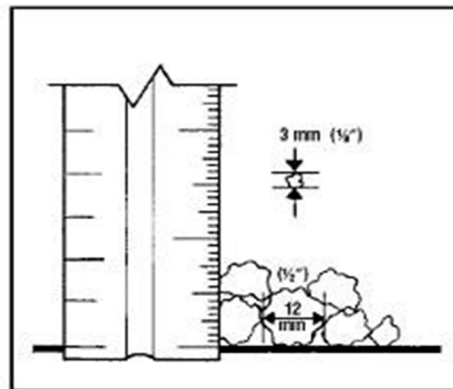

Crushed stone

8.6.3 Top soil:

Clean native top soil shall not contain rocks larger than 36mm on largest dimension.

Note: The use of geo textile barrier fabrics surrounding the primary backfill material is considered good installation practice. The fabric must be chosen to allow the flow of water in and out of the excavation but to prevent the movement of fine soil particles into the primary backfill material.

8.6.4 Burial depth:

Generally, the max depth from finished ground level to the inlet invert level of the main shell should be no more than 725mm for P6 and 785mm for a P12 and P20.

8.6.5 Loadings:

If the plant is installed in an area where traffic or other superimposed loadings can be applied, consult a structural engineer for the design of a reinforced concrete slab to prevent the load being transmitted to the tank (or its concrete surround). If this slab is constructed immediately above the plant, it should be separated from the concrete surrounding the tank by a compressible material.

9. Plumbing the system

Do not: Plumb storm-water (water) from roofs, drains, footpaths etc, into the Tricel Vento septic tank. A competent person in accordance with this manual should connect the plumbing from the dwelling to the septic tank. The Tricel Vento septic tank is plumbed for 110mm, uPVC pipe. The pipe should be vented by means of a vent pipe above the eaves of the house. A short length of pipe with flexible joints should be used immediately before and after the tank to allow for movement between the tank and the pipe work.

9.1 Treatment of effluent liquid:

The Tricel Vento septic tank acts as a holding chamber and treatment of effluent is carried out in the percolation area. Effluent may be disposed into any of any of the following means for treatment:

The best disposal method can depend on a variety of site factors including percolation results, soil type, water table level and topography of the site. Please refer to the onsite engineer for further details.

9.2 Distribution box:

A distribution box and/or inspection chamber should be fitted between the tank and the percolation area. A Distribution box is required to spread the flow throughout a percolation area. An access chamber should be placed before and after the Tricel Vento septic tank for sampling and inspection purposes and also to assist in any blockages that may occur.

Distribution box. 450mm high x 300mm opening



Riser extension. 300mm opening x 270mm high



9.3 Ventilation:

Ventilation is crucial to the system. Prior to installing the system, great care must be given, on how to provide adequate ventilation. As sites differ, advice is available from BS8301, BS6297, EPA CoP 2009. The Tricel Vento septic tank is supplied with 1No 110mm socket next to the inlet pipe which may be used for venting the tank if vent through the eve is not possible.

10. Maintenance

Note: All maintenance work should be carried out from outside the tank. There is never a need to enter the septic tank.

A certain amount of unit maintenance is required, on an ongoing basis to ensure that the system is working correctly. This is the responsibility of the homeowner.

10.1 Quarterly Maintenance (3 months):

The outlet distribution box should be checked monthly to ensure that the, effluent is free flowing and clear. The vent should be checked to make sure they are not blocked or covered with over grown grass.

10.2 Yearly maintenance:

De-sludging should be also carried out yearly to prevent solids rising to the height of the outlet pipe and being carried along with the liquid into the percolation trenches. This blocks the percolation area and can cause flooding. Depending on usage and house population, this period may vary. The de-sludging of the Tricel Vento septic tank is the responsibility of the homeowner. De-sludging is

done with a vacuum tanker (we recommend the use of a licensed company). The minimum recommended desludging period is 1 year for all tank sizes.

10.2.1 De-sludging (emptying the solid waste)

- Remove both access covers.
- Remove the filter.
- Empty the Tricel Vento septic tank using a vacuum tanker. Care must be taken not to damage the tank with the hose of the vacuum tanker.
- Ensure that all the solids are removed from the tank.
- Replace the de-sludging access cover securely.

Notes:

- Do not let this equipment drive over the tank. Maintain a distance of at least 4 meters away from the covers of the tank.
- The access cover should never be left off while the unit is unattended.
- De-sludging should never be carried out alone.

The property owner has a legal responsibility to ensure that the system does not cause pollution, a health hazard or nuisance.

11. Operating conditions:

Please read the operating conditions carefully.

- The manufacturer's instructions outlined in the technical manuals must be followed at all times.
- It is important that the plant is operated under the conditions for which it is designed. Any variation in these conditions could lead to the unit not performing to its full potential.
- De-sludging is a critical part of the successful operation of the Tricel Vento Septic tank. Only competent approved personnel should carry out de-sludging.
- The discharge to the ground is also a critical part of the operation of the system. Correctly constructed distribution chamber and distribution drains or polishing filters are necessary as part of the treatment process. Incorrectly constructed drains or polishing filters could result in poor treatment of effluent and we do not accept any responsibility in this regard.
- If the plant is not installed correctly, flooding, overloading, or floatation may occur. We are not responsible for incorrectly installed systems.

- Soak ways, drains and the emptying of primary tanks remain the responsibility of the client and damage to the installation due to the influx of surface water or the backing up of soak ways or drains is not covered by the manufacturer.
- We shall not be liable for any damage or loss, including consequential loss, caused by the failure of any plumbing equipment or failure caused by the inclusion of gross solids, (e.g. – disposable diapers or sanitary towels etc) in the septic tank.

To ensure the continuance of the plants performance, the user has to take certain precautions including the following:

- The design loading of the plant should not be exceeded.
- High volume discharges such, as those from swimming pools and Jacuzzi's must never enter the plant.
- Surface water must not enter the plant.

Do not allow large quantities of chemicals to enter the system including:

- Water softener regenerate.
- Disinfectants.
- Strong acids and alkalis, or photographic chemicals.
- Oil or grease.
- Petrol or diesel.
- Pesticides.

Do not allow any of the following into the system:

- Large quantities of milk, alcohol or food.
- Large quantities of bleaches or cleaners
- Baby wipes, cosmetic and cleaning wipes
- Sanitary towels
- Kitchen paper
- Nappies
- Tampons
- Medication

Service personnel must be accommodated with clear access to the plant.

If the plant has been sized by others, we will supply a plant to these specifications. In this case, the responsibility lies with others, in relation to the maximum flow / litres per day, the system capacity and retention times.

If we size the plant, and a greater load is placed on the system by the addition of extra houses, bedrooms in the houses, schools, crèche etc. or by any other means, we are not responsible for the plant in terms of overloading or the quality of the effluent as the retention times may be compromised.

- The plant is not suitable for vehicular traffic. We also recommend fencing off the area to prevent livestock herds from accessing the unit. Where possible, unnecessary human traffic around the tank should be avoided

Terms & conditions

Subject to our standard terms and conditions, which are available on request.

This page is intentionally left blank

This page is intentionally left blank

This page is intentionally left blank



Tricel (Killarney) Unlimited Company Trading as Tricel
Ballyspillane Ind. Est. Killarney, Co. Kerry, Ireland
Tel: +353 (0)64 663 2421 | Email: sales@tricel.ie | www.tricel.ie

Tricel Environmental UK, A trading brand of Dewey Waters Ltd
Heritage Works, Winterstoke Road, Weston-Super-Mare, BS24 9AN, United Kingdom
Tel: 44 (0) 1934 422 311 | Email: environment@tricel.co.uk | www.tricel.co.uk

In accordance with Tricel normal policy product development these specifications are subject to change without notice.