

110MM INLET

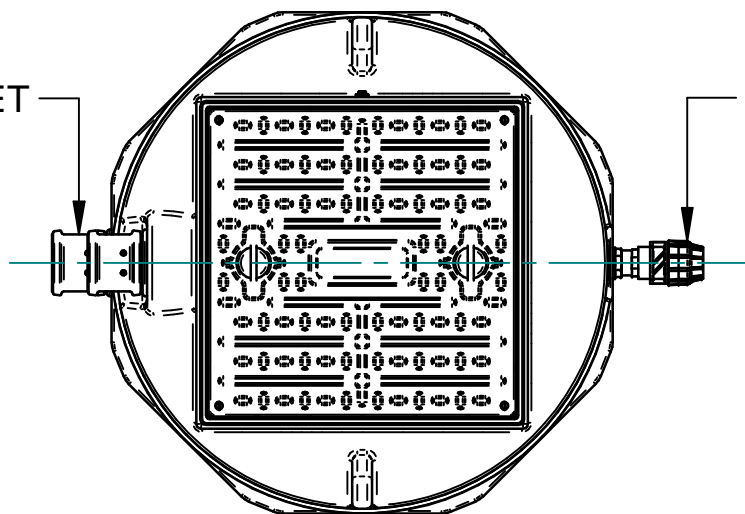

OUTLET SIZE:  
50MM FOR EFFLUENT / WATER  
63MM FOR SEWAGE

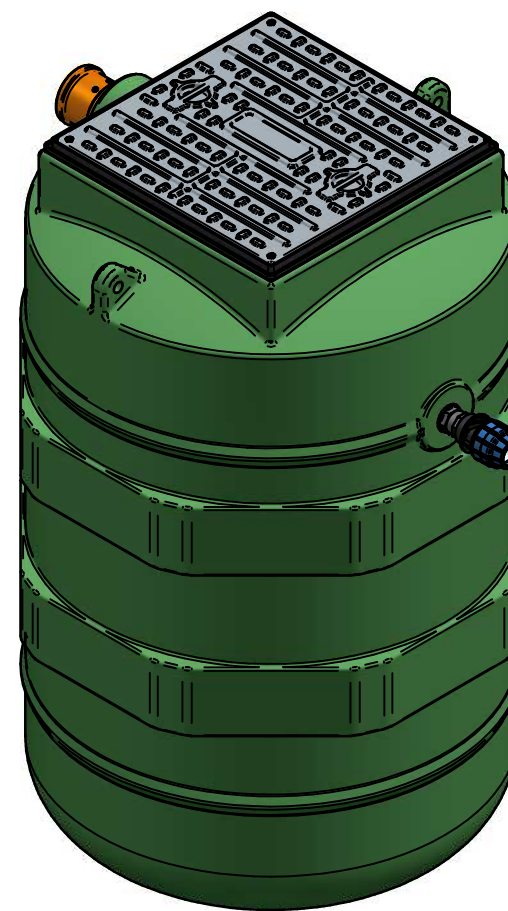

600x600MM COVER  
DOUBLE SEALED  
C/W LOCKING SCREWS

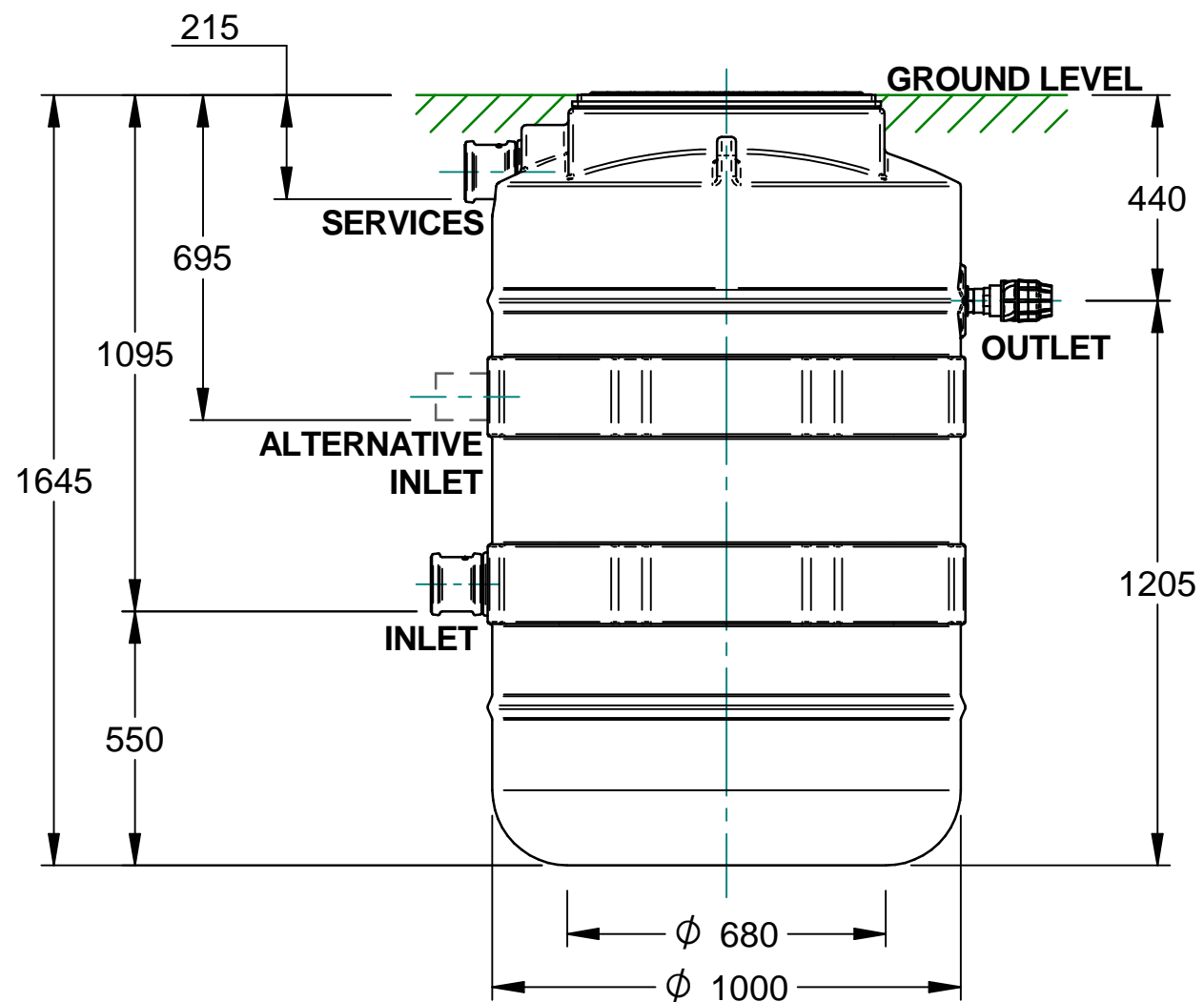
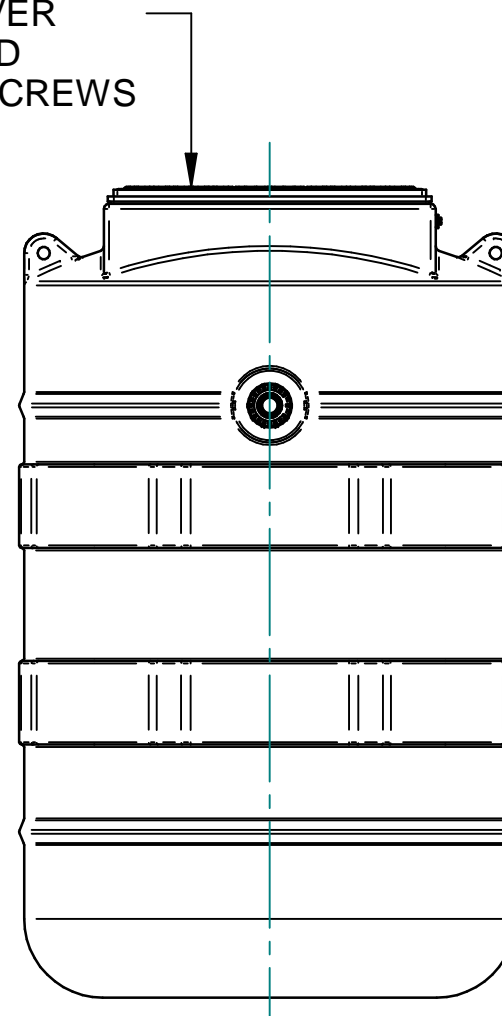

Available in single or twin pump configurations for rain water, effluent or sewage

Revision	Issue Date	ECN Reference

THE INFORMATION, DATA, AND DRAWINGS EMBODIED IN THIS DOCUMENT ARE STRICTLY CONFIDENTIAL AND ARE SUPPLIED WITH THE UNDERSTANDING THAT THEY WILL NOT BE DISCLOSED TO ANY THIRD PARTIES WITHOUT THE PRIOR WRITTEN CONSENT OF HARLEQUIN MANUFACTURING LTD

**COPYRIGHT Sole property of Harlequin Manufacturing Ltd All rights reserved**

UNLESS OTHERWISE SPECIFIED: DIMENSIONS ARE IN MM  
LINEAR TOLERANCE  $\pm$  0.25mm, ANGLES  $\pm$ 0.5°

DO NOT SCALE DRAWING - Use Figure Dimensions Only

IF IN DOUBT, ASK

TITLE: **1100LT Pump Station**

NOTES:

DWG NO: 17-003-001	ISSUE DATE: 01/07/2020
REVISION: 00	DRAWN BY: JC
SHEET: 1 of 1	
FILE NAME: 1100LT Pump Station.dft	

**Harlequin**  
MANUFACTURING FOR TOMORROW

Harlequin Manufacturing Ltd  
21 Clarehill Road  
Moira  
Co. Armagh  
BT67 0PB  
www.harlequin-mfg.com