

ORIENTATION :A

INLET : Ø225 Quantum Plain Spigot
 OUTLET : Ø225 Quantum Plain Spigot

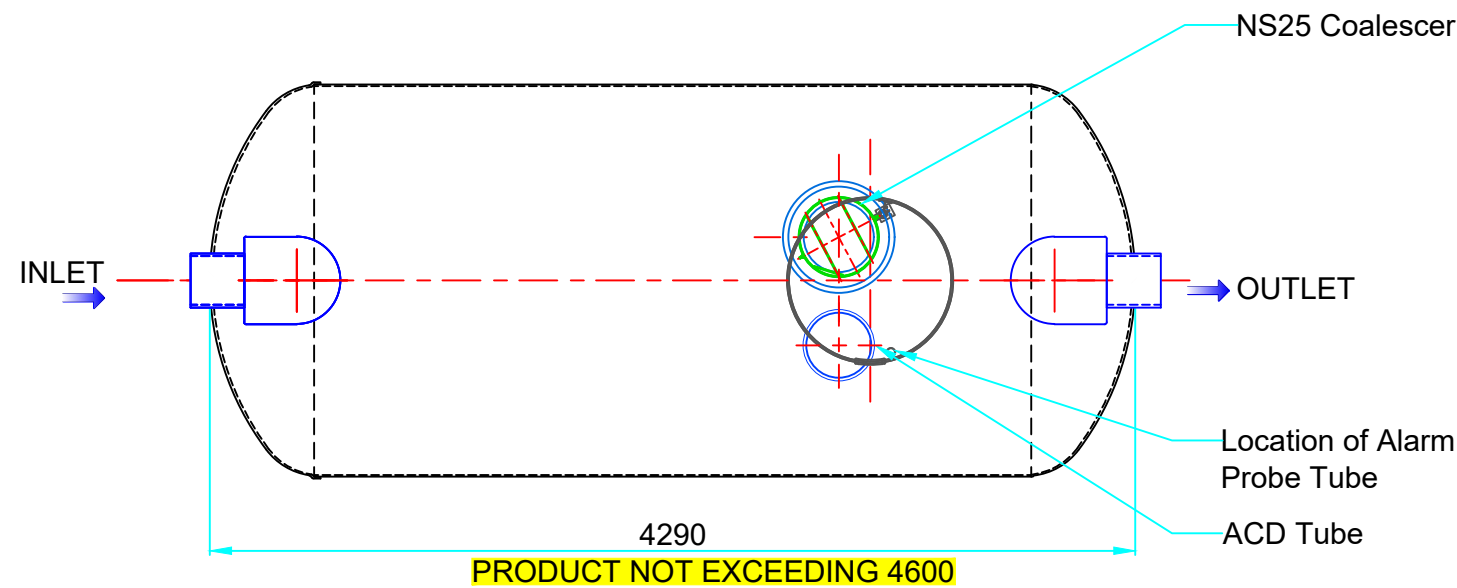

Key to Symbols: \triangle Lifting Point

\circ Hold-down strap rib locations where mechanical anchoring is required

\square Manufacturing Joint

\bigcirc BoQ's reference no.

This drawing is confidential and must not be copied, reproduced or passed to a third party without written permission from
SPEL PRODUCTS

DIMENSIONS ARE SUBJECT TO DIMENSIONAL TOLERANCES. If critical, check physically prior to installation

Water table & Burial Depth: The customer must check tank specification is compatible with ground water table level (in winter) and burial depth. If in doubt refer to SPEL Data Manual Section 13 or contact SPEL Products Sales or Technical Department

Title: **SPEL 300 Series Puraceptor FP1C/SC - Orientation (A)**

Contract:

Gross Capacity
 10,000 Ltrs

Tank Specification
STANDARD

Laminate Specification
 GP

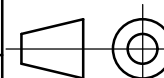

All sizes in mm
 If in doubt ASK!

SPEL
 Lancaster Road, Shrewsbury
 Shropshire, SY1 3NQ, England
 Telephone: +44 (0)1743 445200
 www.spelproducts.co.uk

Drawn
 Checked
 Date

TANK SERIAL No.

INTERNAL ORDER No.

1:35 Sheet A3

Revision

A

| | | | | |
|--------------|------|-----|------------------------------------|-----|
| Distribution | Date | Rev | Issued only for purpose indicated: | BY: |
| | | | | |