

Ø63mm or Ø90mm MDPE Outlet

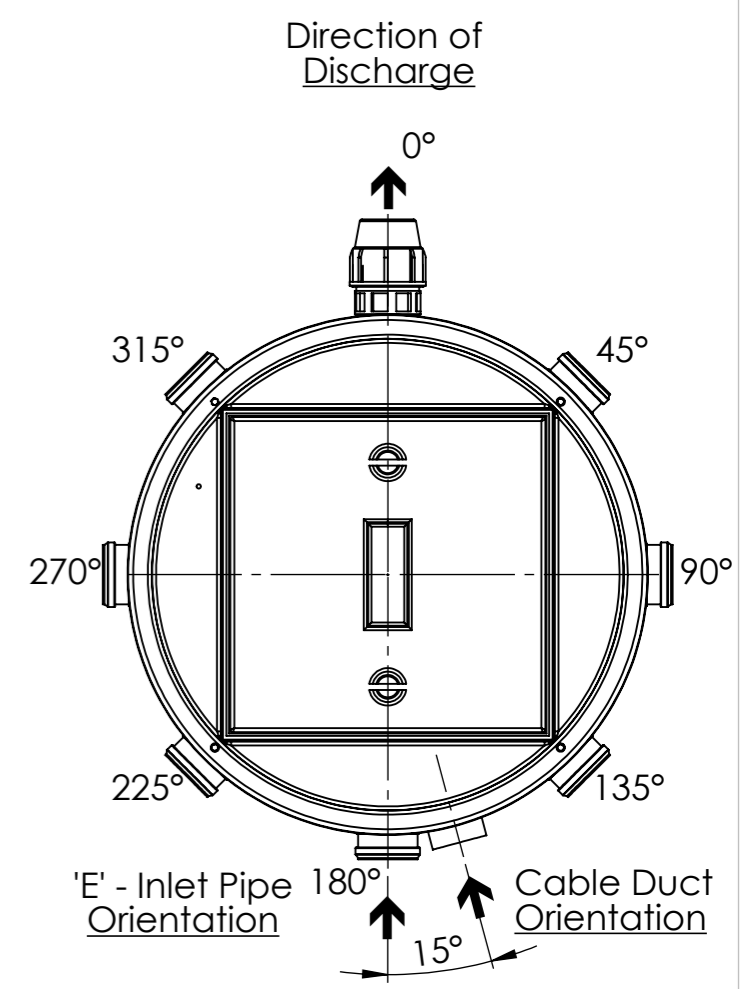
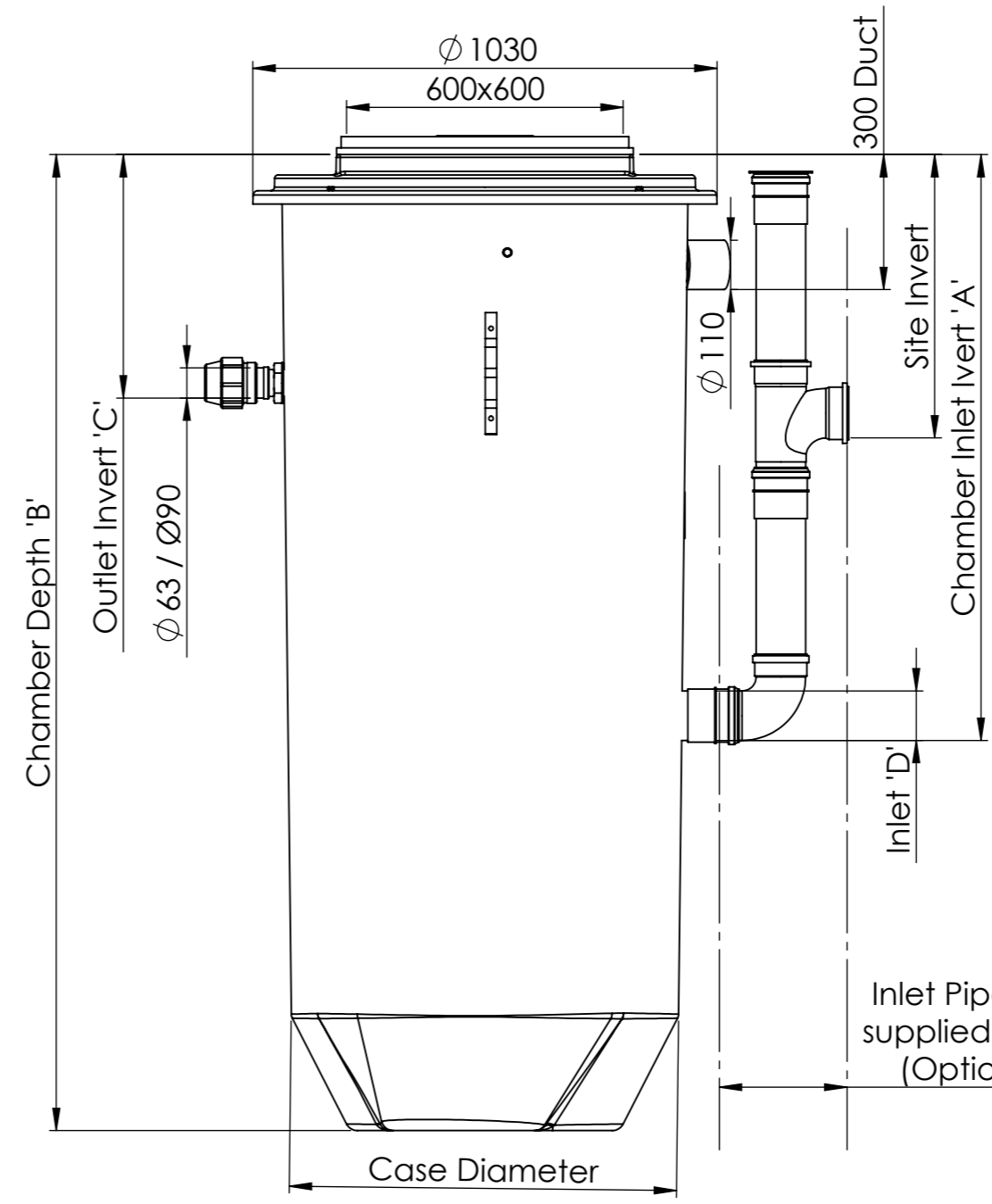
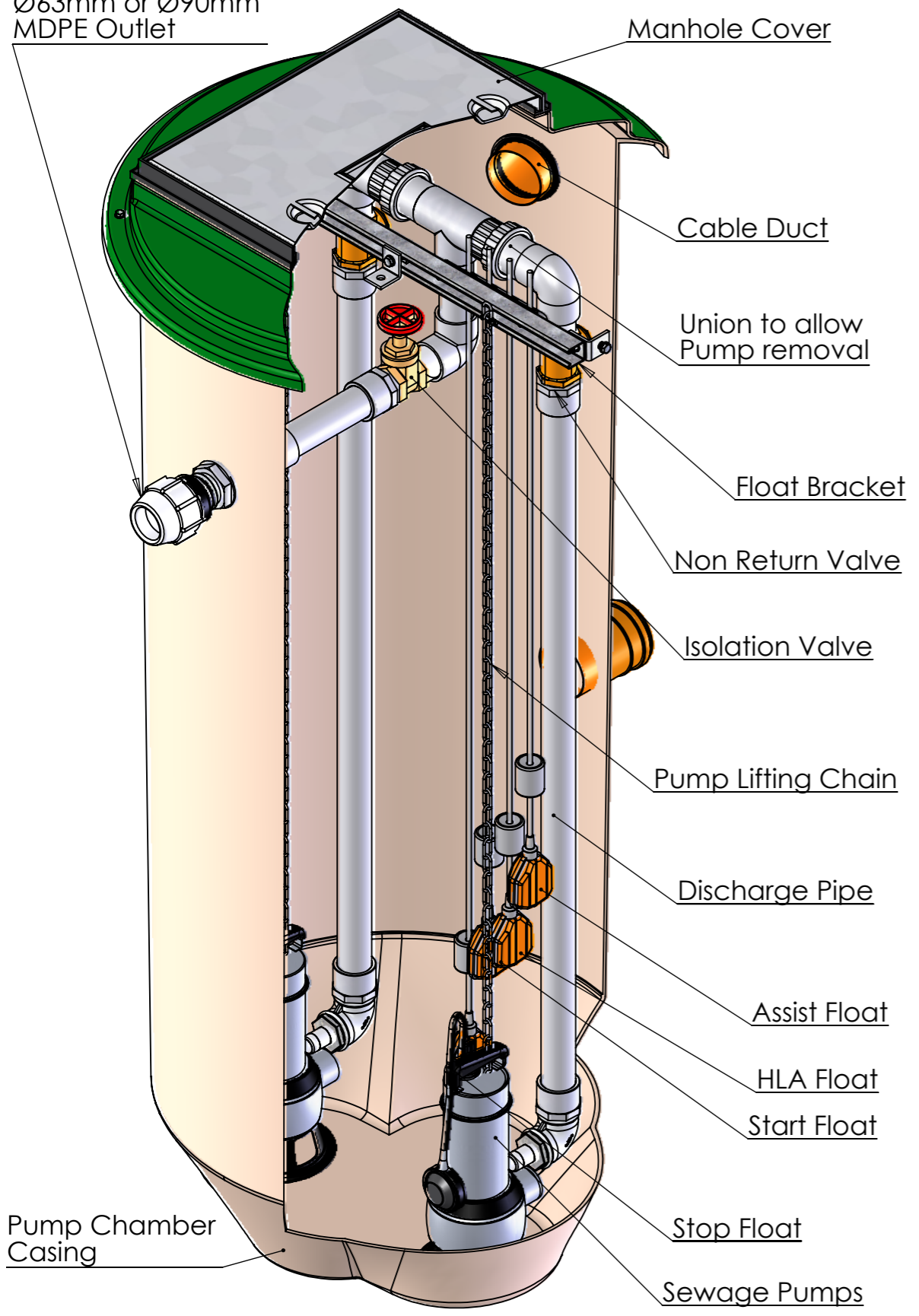

- Notes:**
- Pumpwell delivered with Control Panel and Float Switches not installed to avoid damage in transit.
  - Read Operating and Installation Guidelines before installing.

Case Diameter	Outlet Invert 'C'	Chamber Depth 'B'			Inlet Invert 'A' - Standard			Inlet Size 'D'	Inlet Positions 'E'
		Chamber A (2.16m)	Chamber B (2.67m)	Chamber E (1.58m)	Chamber A (1.3m)	Chamber B (1.8m)	Chamber E (0.7m)		
Ø900mm	535mm	•			•			Ø110mm or Ø160mm	0°, 45°, 90°, 135°, 180°, 225°, 270°, 315°
			•			•			
				•			•		

Please check with Kingspan Water & Energy for the latest Issue of the drawing				
Issue	Date	Drawn By	Approved By	Description
06	15/12/2022	TGY		ECN 1641 - Access Size Added
05	31/05/2019	J.Belovic		CC1488 - Adding Inlet Pipe Orientation

LN Number :  
 Finish :  
 Weight : 83.41 Kg  
 Modelled By : Name

Tolerance (unless stated) :  
 Thickness : n/a  
 Surface Area : m<sup>2</sup>  
 Material : Various

**Drawing : DS1172P** Page 1 of 1

Ø0.9m Domestic Pump Chamber Assembly

All Dimensions In mm Scale: Do Not Scale

  
 Third Angle Projection

A:\Wastewater\Engineering\Drawing Data\02 - Sales Drawings\DS\DS - 11\DS1172P

Kingspan Water & Energy reserve the right to alter the details of this drawing without prior notice. This drawing is copyright and may not be reproduced or used without the written permission of Kingspan Water & Energy

