

NOTES:-

1. UNITS CAN BE PROVIDED WITH EXTENSION SHAFTS IN 0.5m INCREMENTS.
2. STANDARD **MINIMUM** INLET/OUTLET PIPES ARE Ø160mm. PVCu UNDERGROUND DRAINAGE TO BS 4660. FOR OTHER PIPE SIZES AVAILABLE CONSULT SALES.
3. IT IS ESSENTIAL THAT THIS DRAWING IS READ IN CONJUNCTION WITH GUIDELINES SUPPLIED WITH UNIT GIVING INSTALLATION DETAILS. THIS DRAWING SHOULD BE USED FOR DIMENSIONAL INFORMATION ONLY.

UNIT	WORKING CAPACITY (Litres)	DIM. 'A'	DIM. 'B'	DIA. 'C'	DIM. 'D'	APPROX. WEIGHT (kg)	
						EMPTY	FULL
STS100	10000	3960	700	1917	2560	400	10400
STS120	12000	4750	700	1917	3350	450	12450
STS150	15000	5780	700	1917	4380	550	15550
STS190	19000	7355	900	1917	5555	650	19650

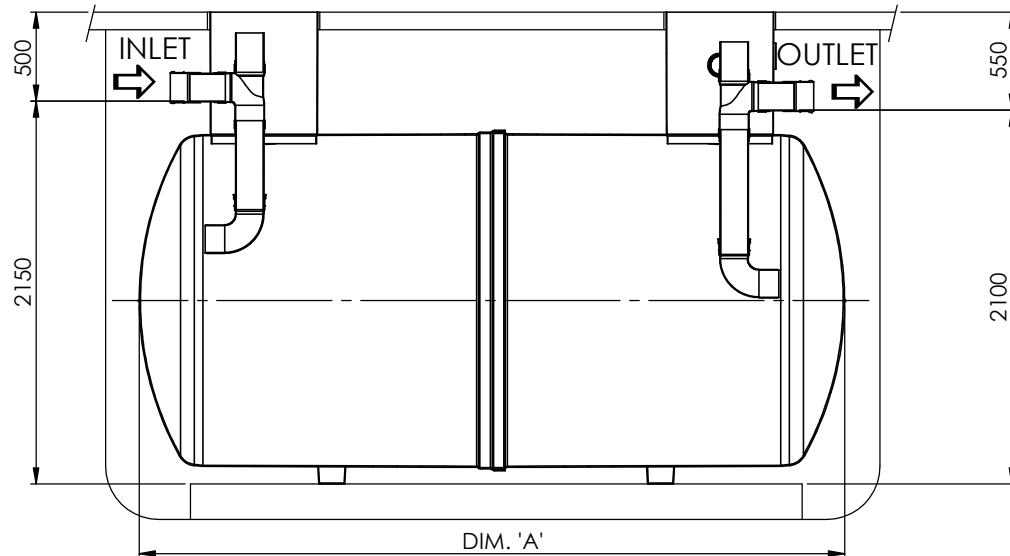

SECTION A-A

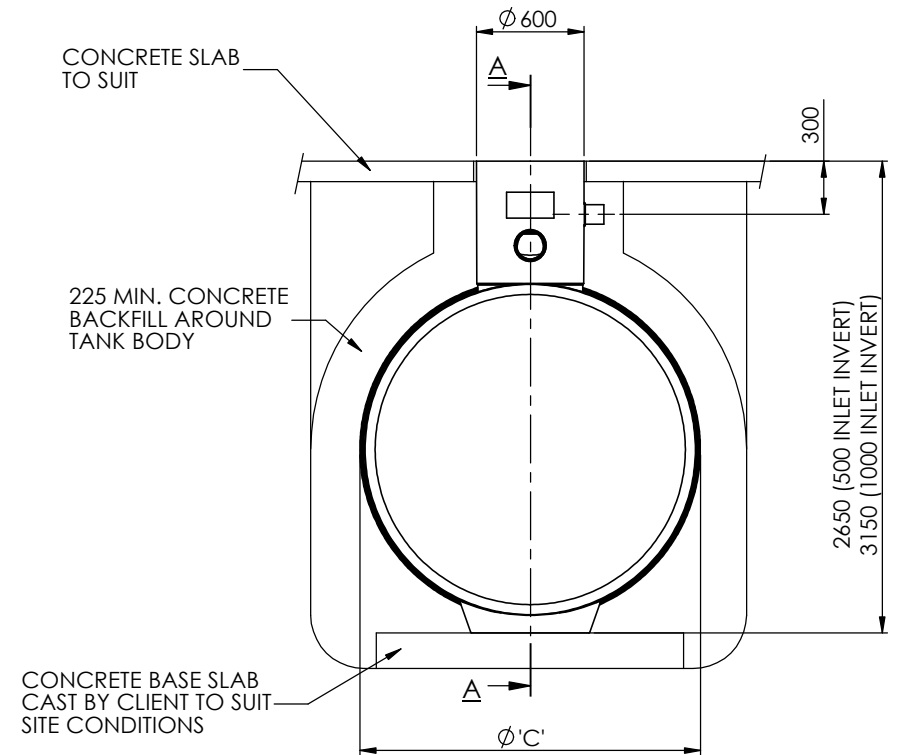

Please Check with Kingspan Environmental For The Latest Issue Of This Drawing				Material : Various	Tolerance (unless stated) :
Issue	Date	Drawn by	Approved by	Finish :	Thickness : n/a
03	30/03/16	L.Steward		Weight : 337.46 Kg	Surface Area : m <sup>2</sup>
02	30.10.14	T.Kelly		Modelled By : Name	

Drawing : DS0634P

10,000L To 19,000L Septic Tanks

All Dimensions In mm

Scale: Do Not Scale

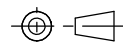

Third Angle Projection

T:\Drawing Data\02 - Sales Drawings\DS\DS - 06\DS0634P - 10000L To 19000L Septic Tanks

Kingspan Environmental reserve the right to alter the details of this drawing without prior notice. This drawing is copyright and may not be reproduced or used without the written permission of Kingspan Environmental

