

BioFicient 1-3

INSTALLATION MANUAL



BIOFICIENT 2-3 GRP - GRAVITY



BIOFICIENT 1 MDPE - GRAVITY



BIOFICIENT 1 MDPE - IPS

Part Code	Issue	Description	Date
017902	03	CC1282	February 2016

Contents

Health and Safety	Page 3
Desludging	Page 4
Self Help	Page 5
System Overview	Page 6
BioFicient Checklist	Page 7
Installation	Page 8-10
Control Panel Installation	Page 11
Start up	Page 13



HEALTH AND SAFETY

You must read these warnings carefully before installing or using the equipment. Should the equipment be transferred to a new owner, always ensure that all relevant documents are supplied. Observe all hazard labels and take appropriate action to avoid exposure to the risks indicated. Take care to maintain correct posture, particularly when lifting. Use appropriate lifting equipment when necessary.



- Only experienced contractors should carry out installation, following the guidelines.
- The unit should have a Pre-Service Agreement Inspection by an approved engineer.
- A qualified electrician should carry out electrical work.
- Covers must be kept locked.
- Observe all hazard labels and take appropriate action to avoid exposure to the risks indicated.

CLOTHING

- We recommend the use of a dust mask and gloves when cutting GRP components.
- Any person carrying out maintenance on the equipment should wear suitable protective clothing, including gloves.



MAINTENANCE AND INSPECTION PROCEDURES

- Should you wish to inspect the operation of the equipment, please observe all necessary precautions, including those listed below, which apply to maintenance procedures.
- The power supply to the equipment must be isolated at the control panel(s) before lifting the covers.
- If the equipment has to run with the covers off, all care must be taken to avoid contact with moving parts and electrical components or conductors.
- Once power has been isolated, the control panel must be kept locked shut to avoid accidental re-connection whilst work or inspection is being carried out.

WORKING AREA

- Ensure that the working area is adequately lit.
- Ensure that you are familiar with the safe working areas, accesses and that the area is adequately lit.
- Use only the designated access walkways. Do not walk on the cover or deep well safety mesh(es).
- Keep proper footing and balance at all times. Avoid any sharp edges.

DESLUDGING

- Desludging should be carried out by a licensed waste disposal contractor holding the relevant permits to transport and dispose of sewage sludge.

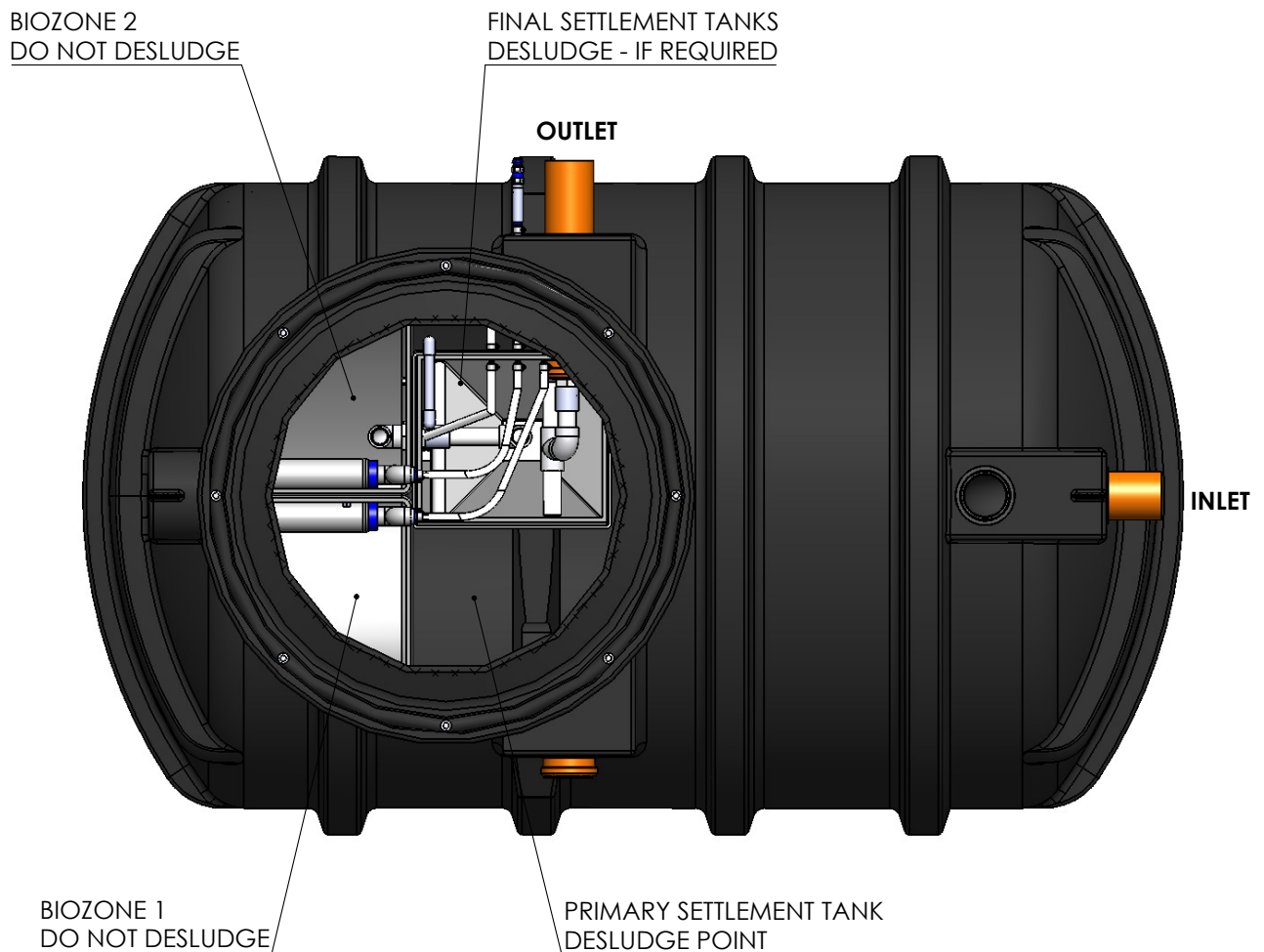

Desludge Volumes

Model	BFG 1	BFG 2	BFG 3	BFG 4	BFG 5	BFG 6
Primary Settlement Tank	2000 Ltrs (440 gal)	3600 Ltrs (800 gal)	3600 Ltrs (800 gals)	4700 Ltrs (1040 gal)	6400 Ltrs (1420 gal)	12300 Ltrs (2730 gal)
Final Settlement Tank	54 Ltrs (12 gal)	90 Ltrs (20 gal)	90 Ltrs (20 gal)	135 Ltrs (30 gals)	180 Ltrs (40 gal)	270 Ltrs (60 gal)
Desludge Period	12 Months Maximum	12 Months Maximum	12 Months Maximum	9 Months Maximum	9 Months Maximum	9 Months Maximum

SELF HELP

In order to minimize the need for dealing with emergency situations we recommend that Treatment Plants have a Pre-service Agreement Inspection, and then is regularly serviced by us or an approved Service Engineers. Provided that your plant is installed, operated correctly and serviced, you should not need to get into much – if any – self-help.

However, some of the most likely question and answer situations are listed below.

Blower

Blower Stopped:

- Check the unit is switched on, the incoming power supply circuit and fuse.

Blower works but no water distribution inside the plant:

- Check hose connections.
- Check distributor heads.
- If the air lift pipes are suspected to be blocked, call for service.
- Check regulating valve is not closed.



Plant flooding

- Check for blocked outlet system.
- If pumped outlet, check for pump operation, check floats and pump power supply.

Plant odour

- Check blower working.
- If blower working, plant probably needs desludging.
- Check vent circuit is clear.
- Check that the air duct entering the blower housing has been sealed with foam.

DO's



Do take out a service agreement and let the experts look after your plant.
Do contact us for advice if you have any cause for concern.

DON'TS



Don't pump feed the plant without reference to us.
Don't use a waste disposal unit as you will be adding to the biological load, and your system may not be large enough to cope with the waste. If you are unsure please refer to our sales team for guidance.
Don't throw any medicines down the toilet.
Don't empty large quantities of bleach or similar cleaning reagents into the system.
Don't empty cooking oil or similar down the sink.
Don't cover the plant with soil material or prevent access for service and desludging.
Don't apply a hose or jet wash to the biological filter unless specifically advised to.
Don't try to enter the plant
Don't put sanitary towels, incontinence pads, nappies, tampons or other non-biodegradable items' down the toilet.

SYSTEM OVERVIEW

Pictorial representation below indicates basic requirements for a standard system, please note not all of the items required are supplied by Kingspan.

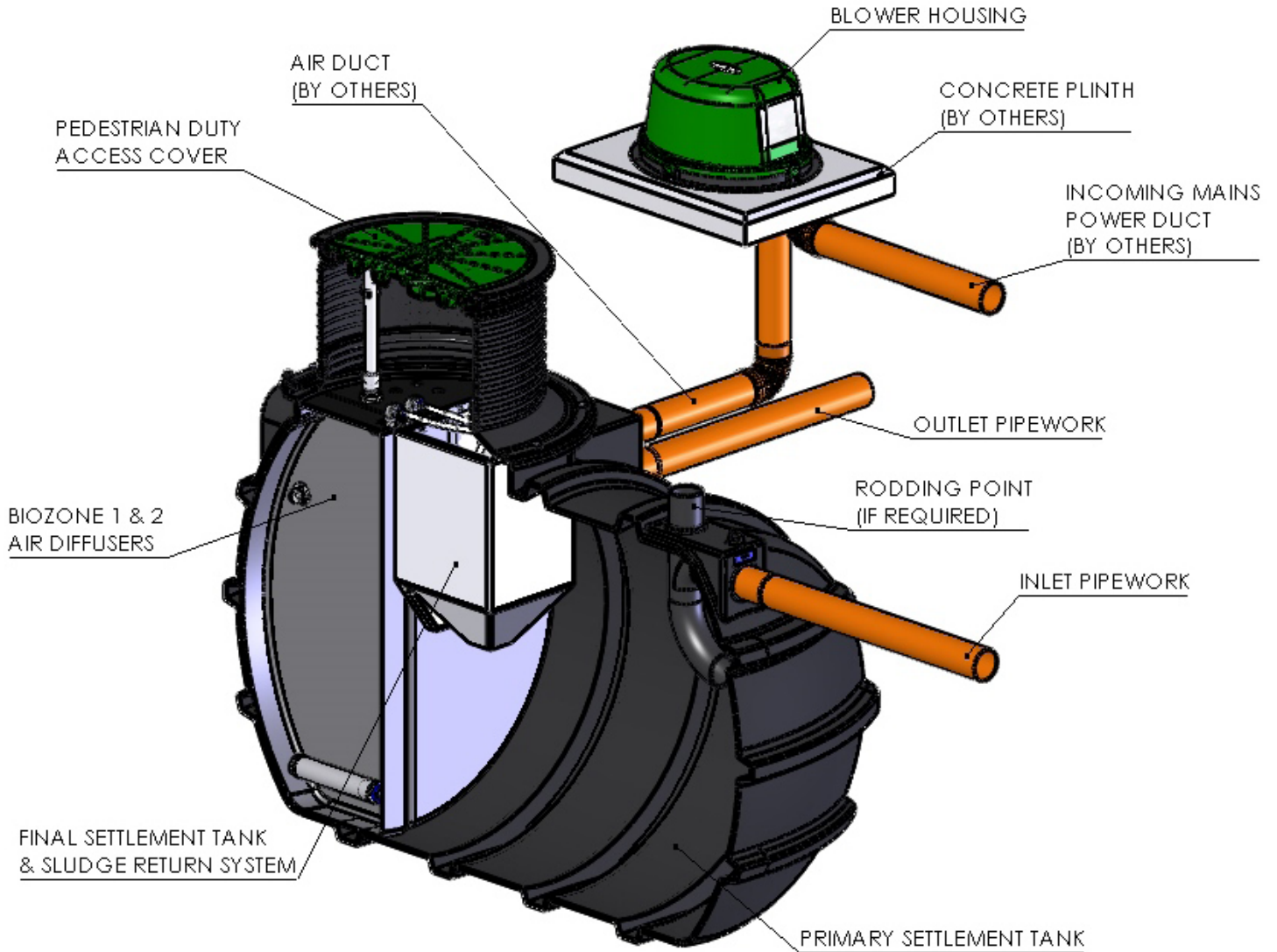

BioFicient® CHECKLIST

The delivery paperwork will have 3 no. items listed; check that the Tank Code (Item 1) & Blower Assembly Code (Item 2) are the same as the codes on the units delivered.

Example;

Top Level Product Code – BFP1GPPK

Item 1 – BFPTANK1GK (Tank Code)

Item 2 - BHBF1GOK (Blower Assembly Code)

Sewage Treatment Tank

Item 1

NB: Storage tanks vary in design and volume (6PE to 10PE) Please check your particular order and cross reference with relevant sales drawing. (BioFicient MDPE Gravity shown)



Blower Housing Assembly

Item 2

The Blower Assembly consists of the Blower Unit, Control Panel or Isolator, Solenoid Valve and associated pipework and fittings.



13 mm Hose Coil - 15 Metres

Item 3

13 mm Hose required to connect from 1/2" Hose Connector in Blower Housing to Sludge return Pipework located with the Tank). (Supplied inside Blower Housing Packaging)



19 mm Hose Coil - 15 Metres

Item 4

19 mm Hose required to connect from 3/4" Hose Connector in Blower Housing to Air Diffuser Manifold located with the Tank). (Supplied inside Blower Housing Packaging)



INSTALLATION

1. EXCAVATE A HOLE

Approximate dimensions

Model	Diameter /Width (mm)	Length (mm)	Inlet Invert* (mm)	Outlet Invert** (mm)	Installation depth** (mm)
BioFicient 1	1420	2500	500	600	1795
BioFicient 2	1425	3760	500	600	1830
BioFicient 3	1425	3760	500	600	1830

*BioFicient 1 Inverts available - 500 to 810, 1000 & 1500 mm

*BioFicient 2&3 Inverts available - 500, 1000 & 1500 mm

**Based on 500mm invert



2. LAY CONCRETE BED 150-200 MM



3. LOWER UNIT ONTO CONCRETE

Should not be lifted with any water inside



4. BACKFILL AND LEVEL

1. Pour 300 mm of water into the tank,
2. Backfill with pea gravel or similar. Pea gravel is reliant on use of correct strapping and anchoring.

Wet site: Make sure the base is adequate to support the weight of the tank and its contents. If the base is unstable excavate an additional 250-300mm below the concrete levels and fill up with compacted hard-core.

Check that the inlet and outlet orientation is correct and that the unit is level.



Water levels always higher than backfill

5. REMOVE TEMPORARY COVERS AND CONNECT INLET AND OUTLET PIPEWORK

6. CONTINUE TO BACKFILL

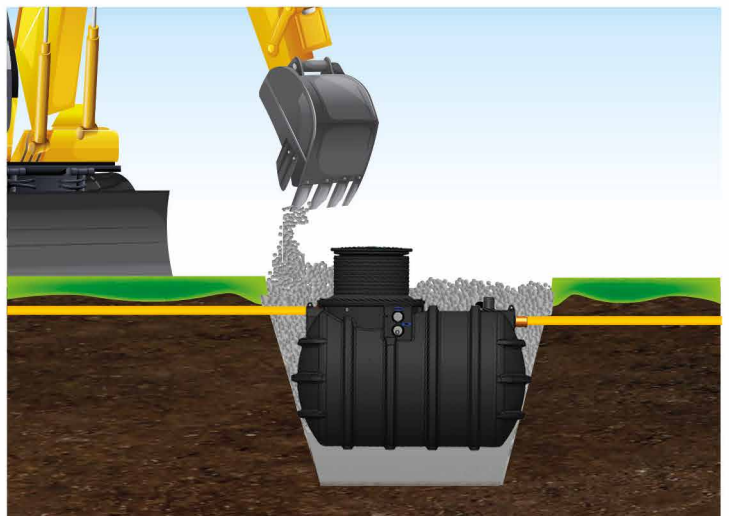
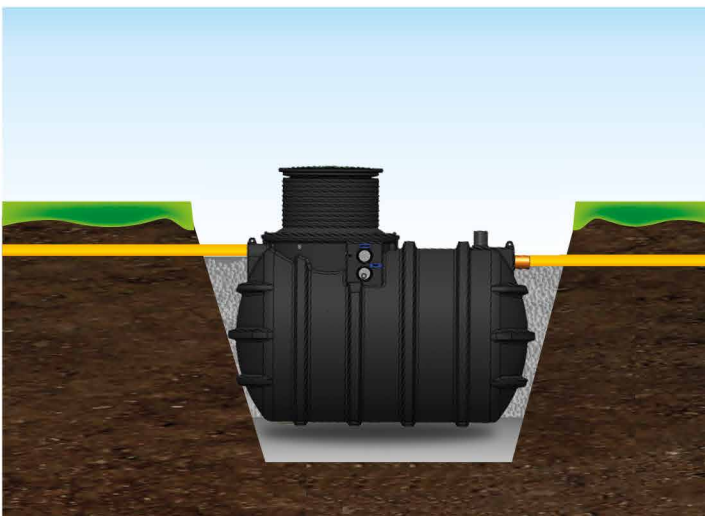

Gravity Unit – Inlet \varnothing 110mm uPVC Pipe – Outlet \varnothing 110mm uPVC Pipe
IPS Unit - Inlet \varnothing 110mm uPVC Pipe – Outlet \varnothing 50mm O/D MDPE Pipe

7. VENTING

To be vented locally at the plant

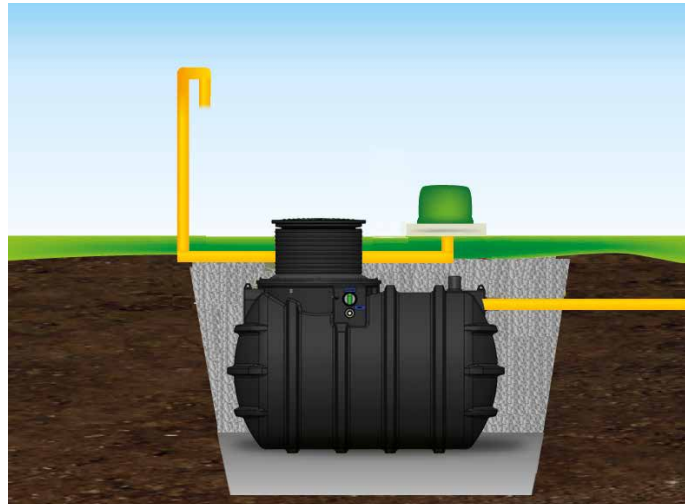

CONTROL PANEL INSTALLATION

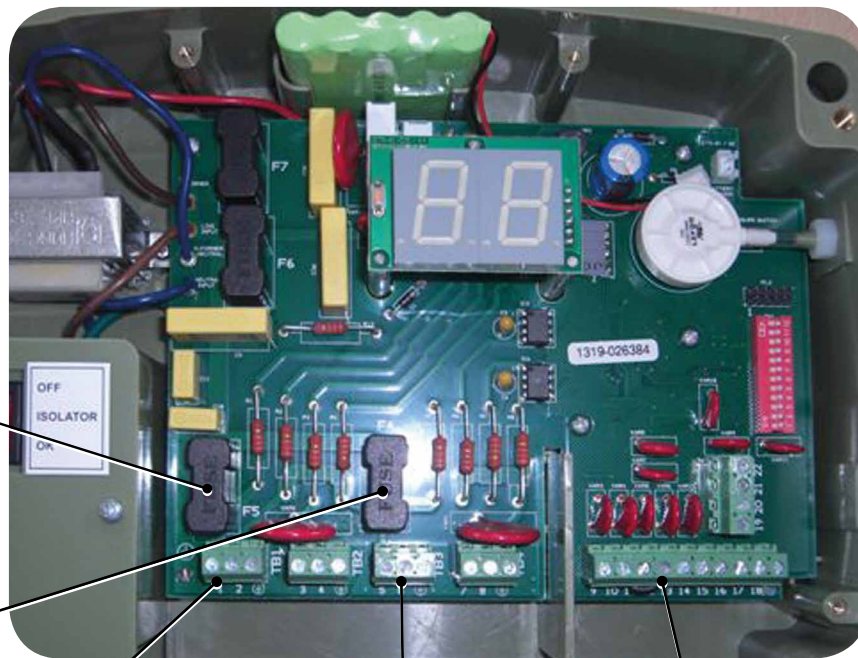

Fuse 5 A
 Discharge pump

Fuse 3,15 A
 Motor drive

TB1
 Discharge Pump/ Solenoid Valve
 Phase (red)
 on « 1 »
 Neutral (black)
 on « 2 »
 and Ground
 (if applicable)

TB3
 Blower
 Phase (red)
 on « 5 »
 Neutral (black)
 on « 6 »
 and Ground

TB6
 High water level
 detector.
 Wire1 (red)
 on « 11 »
 Wire 2 (black)
 no connection
 Wire 3 on « 12 »
 (if applicable)

TB7
 Remote beacon
 Phase (red)
 on « 16 »
 Neutral (white)
 on « 17 »
 and Ground (black)
 on « 18 »
 (if applicable)

BioFicient® IPS HLA

1. Remove the loose float located in the blower housing.
2. Thread the float cable through the gland in the HLA bracket fixed to the Final Settlement Tank in the plant.
3. Position bottom of the float 200mm from top of the FST and tighten gland to secure the float cable.

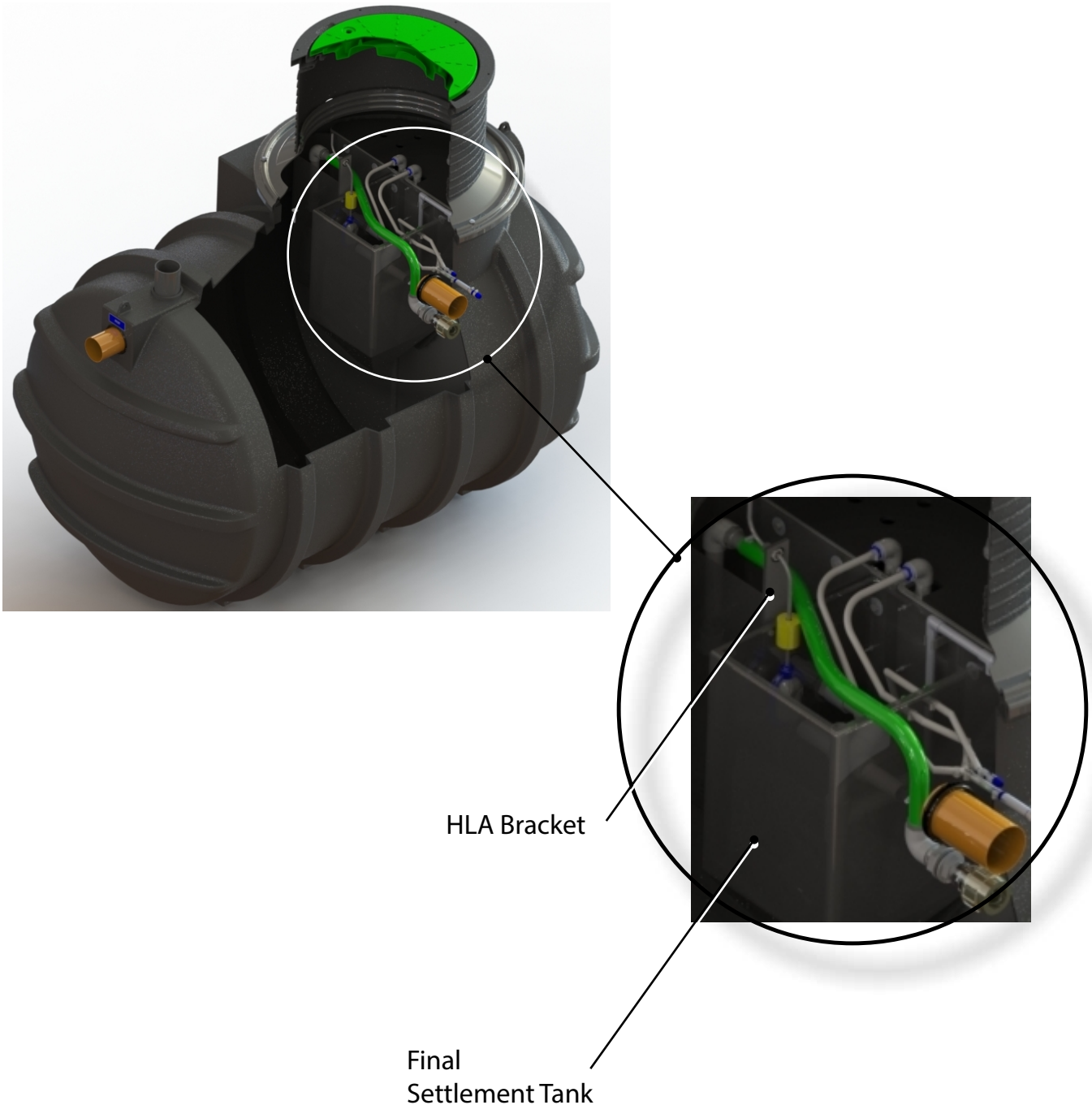

CONTROL PANEL ENTRY POINTS DEPENDING ON THE EQUIPMENT SUPPLY

1 - Pumped discharge only
 2 - See Fig.1 below

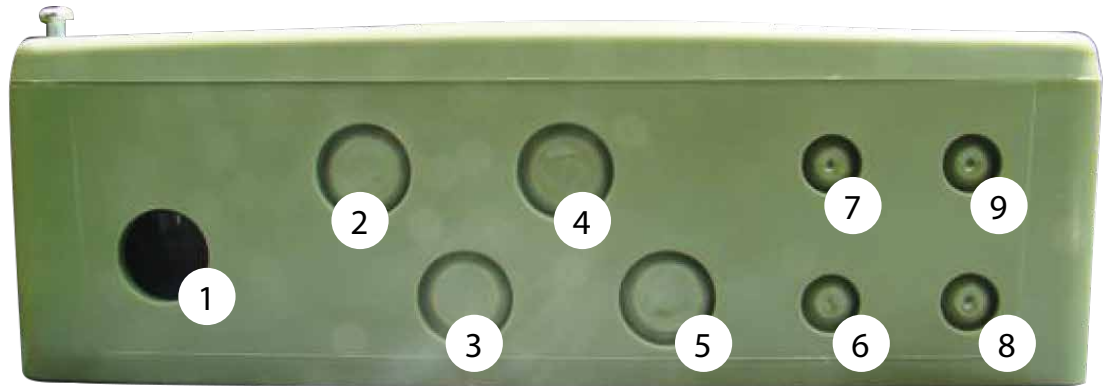

Product	Required Gland	Feed through Gland Hole number	Terminate to connection
Mains power supply	M20	1	
Integral discharge pump power cable	M20	2	1&2
Sludge Return Solenoid Cable (1)	M20	3	1&2
Blower power supply cable (2)	M20	4	5&6
High level alarm cable	M12	7	11&12
Beacon (1)	M12	9	16, 17&18

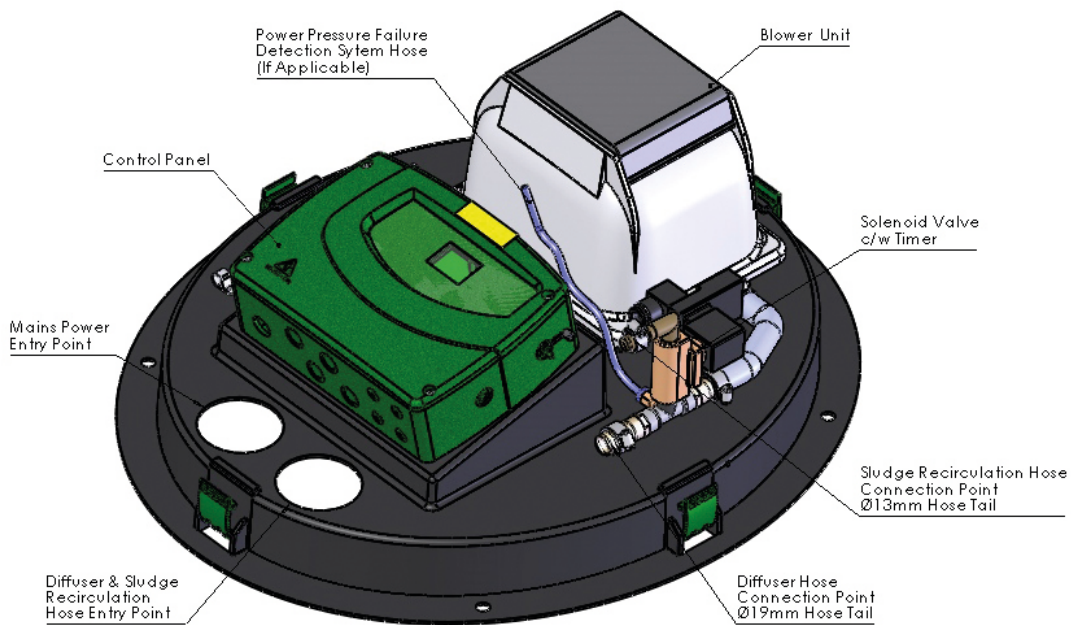

Fig.1 Sludge Return Solenoid

		Full Load Current (Amps) / Electrical Consumption (Kwh)		
		BioFicient 1	BioFicient 2	BioFicient 3
Blower	240 volt single phase	0.4 / 1.27	0.5 / 1.82	0.6 / 1.82

COMPLETING THE INSTALLATION

1. Plug the lead from the battery into the small white socket in the top right corner of the PCB marked "BATTERY HEADER".
2. Power & Pressure Failure Detection System (where applicable) - Using a small screwdriver, push switch 11 to the ON position.
3. Installation of High Level Alarm (where applicable) - Remove the link in the terminal blocks between connections 11 & 12 (TB6) before inserting cables. Using a suitable M12 gland, feed the high level alarm float cable through Gland Hole 7 and terminate to connection 11 & 12 (TB6) – Red to 11 & Black to 12.

FAULT CODES AND FUSES

CODE	FAULT CONDITION	FUSE	Amp
F1	No power to the unit	Customer Fuse box	N/A
F2	The blower pressure has failed	N/A	N/A
F3	The high level alarm has activated (where fitted)	N/A	N/A
F4	The fuse to the motor has failed	F3	3.15
F5	The fuse to the discharge pump has failed (where fitted)	F1	5.0
F6	The fuse to the chemical dosing pump has failed (where fitted)	F4	0.25
F7	The fuse to the recirculation pump has failed (where fitted)	F2	5.0
F8	The loss of rotation alarm has been activated (not applicable)	N/A	N/A
--	The unit has had a fault which has now corrected itself (Flashing left and right - Battery charging Flashing left only - Battery charged)	N/A	N/A

All fuses are Time Lag HBC 20mm type

SLUDGE RETURN SOLENOID RUN AND PAUSE TIME SETTING

TIMER SETTINGS:
ON SETTING = 5 MINS (ie RUN FOR 5 MINS)
OFF SETTING = 60 MINS (ie OFF FOR 60 MINS)

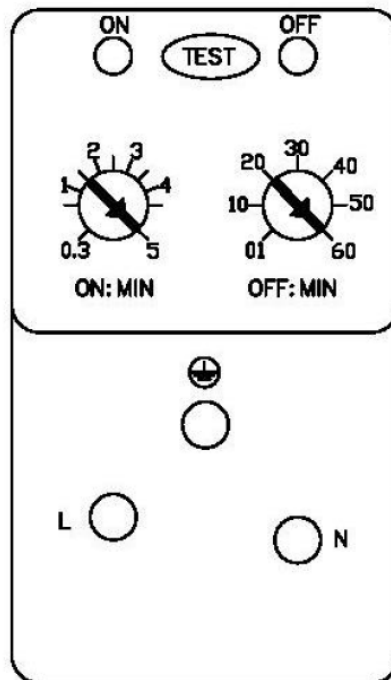

TIMER SETTING DETAIL

The timer should be factory set at the correct settings



Kingspan Environmental Ltd
Unit 1, Derryboy Road
Carnbane Industrial Estate Newry,
BT35 6QH
Newry

GB T: 084 48 46 0500
NI T: 028 30 25 4077
IRL T: 048 30 25 4077
www.kingspanenviro.com

Kingspan Environmental
College Rd North
HP22 5EW
Aston Clinton, Aylesbury

