

---

**1011359**  
BTA-1 – BTAU5 Treatment Plant  
Installation & Operation Guidelines

---



Contact Numbers:

Sales Office Details

Tel: UK: 01296 633 033

E: [water@kingspan.com](mailto:water@kingspan.com)

[www.kingspan.com](http://www.kingspan.com)

Service Office Details

Tel: UK: 0333 240 6868

E: [serviceGB@kingspan.net](mailto:serviceGB@kingspan.net)

[www.kingspanservice.com](http://www.kingspanservice.com)

<b>Enclosed Documents</b>
---------------------------

<b>DS1380</b>	<b>BTA-1 Gravity Treatment Plant</b>
<b>DS1381</b>	<b>BTA-1 IPS Treatment Plant</b>
<b>DS1384</b>	<b>BTAU2 &amp; BTAU3 Gravity Treatment Plant</b>
<b>DS1385</b>	<b>BTAU2 BTAU3 IPS Treatment Plant</b>
<b>DS1386</b>	<b>BTAU4 Gravity Treatment Plant</b>
<b>DS1387</b>	<b>BTAU4 IPS Treatment Plant</b>
<b>DS1401</b>	<b>BTAU5 Gravity Treatment Plant</b>
<b>DS1402</b>	<b>BTAU5 IPS Treatment Plant</b>
<b>DS1342K</b>	<b>Gravity &amp; IPS System Isolator Wiring Diagram</b>
<b>1011027</b>	<b>DTP Control Panel Wiring Diagram</b>

<b>Issue</b>	<b>Description</b>	<b>Date</b>
01	ECN 1612	April 2022

## HEALTH AND SAFETY

**These warnings are provided in the interest of safety. You must read them carefully before installing or using the equipment.**

It is important that this document is retained with the equipment for future reference. Should the equipment be transferred to a new owner, always ensure that all relevant documents are supplied in order that the new owner can become acquainted with the functioning of the equipment and the relevant warnings.

Installation should only be carried out by a suitably experienced contractor, following the guidelines supplied with the equipment.

We recommend the use of relevant PPE when working with GRP components.

A qualified electrician should carry out electrical work.

Sewage and sewage effluent can carry micro-organisms harmful to human health. Any person carrying out maintenance on the equipment should wear suitable protective clothing, including gloves. Good hygiene practice should also be observed.

Covers must be kept locked.

Observe all hazard labels and take appropriate action to avoid exposure to the risks indicated.

The correct ongoing maintenance is essential for the proper operation of the equipment. Service contracts are available and recommended. Please contact our Sales department for details of your local service provider.

Should you wish to inspect the operation of the equipment, please observe all necessary precautions, including those listed below, which apply to maintenance procedures.

Ensure that you are familiar with the safe working areas and accesses.

Ensure that the working area is adequately lit.

The power supply to the equipment should be isolated at the main RCD before lifting the blower cover.

Take care to maintain correct posture, particularly when lifting. Use appropriate lifting equipment when necessary. Keep proper footing and balance at all times. Avoid any sharp edges.

Desludging must be carried out by a licensed waste disposal contractor holding the relevant permits to transport and dispose of sewage sludge. The contractor must refer to the desludge instructions contained in these guidelines.

**Contents**

1 Introduction ..... 4

    1.1 Engineering & Process..... 4

    1.2 Applications ..... 4

2 Installation Guidelines ..... 4

    2.1 Siting ..... 4

    2.2 Population Equivalent ..... 5

    2.3 Flow Balancing..... 5

    2.4 Installation ..... 5

    2.5 Site Planning ..... 5

    2.6 Options ..... 7

    2.7 Venting & Blower Housing ..... 7

    2.8 Dimensions ..... 7

    2.9 Self Help..... 7

    2.10 Blocked air lifts ..... 8

    2.11 Pre-service Agreement Inspection..... 9

    2.12 Warranty..... 9

3 Electrical Installation..... 10

    3.1 General Electrical Installation Information ..... 10

    3.2 Isolator - L Range..... 10

    3.3 Control Panel - P Range (Premium) ..... 13

4 Operations ..... 21

    4.1 Standard Rate Treatment Plants ..... 21

    4.2 General Maintenance..... 21

    4.3 Emptying and Desludging ..... 21

    4.4 Emptying and Desludging Procedure ..... 21

    The foul drainage from this property discharges into a package treatment works. .... 23

# 1 Introduction

## 1.1 Engineering & Process

- 1.1.1** Our Packaged Sewage Treatment Plants are designed to treat domestic sewage to an average final effluent of less than 20mg/l Biochemical Oxygen Demand (BOD), 30 mg/l Suspended Solids, and 20mg/l Ammonia when the incoming flow and biological loads are within the limits for the plant as specified by us.
- 1.1.2** These units are exclusively for the treatment of sewage from domestic properties. Contact our sales team for other non-domestic applications.
- 1.1.3** As a general guide the BTA1 is suitable for 6 PE, BTA2 is designed to treat 9 PE, BTA3 suitable for 12 PE, BTA4 is designed to treat 18 PE and BTA5 is designed to treat 25 PE.
- 1.1.4** The Treatment Plant is based on an improved form of trickling biological treatment, which continuously recycles the settled liquor by airlift. Process takes place in 3 distinct stages.
- 1.1.5 Primary Screening & Settlement**
- 1.1.6** Sewage enters the primary section where the solids separate from the liquid forming a scum or a sludge. The settled liquor is then passed on through a dividing baffle into the secondary settlement stage.
- 1.1.7 Biological Treatment**
- 1.1.8** From this secondary settlement stage the liquor is lifted and distributed over the media bale by an airlift.
- 1.1.9** The biological filter bale consists of a composite plastic media of high specific surface area. This is where the biological process takes place with biomass forming on the surface of the media. The biomass consumes the major part of the incoming biological load.
- 1.1.10** The air lift is driven by a blower mounted within a weatherproof housing which should be located in a shaded position above possible flood levels. The supply of air from the blower provides adequate oxygen to the plant. Air from the plant can be vented by either the soil vent pipe or by a separate vent.
- 1.1.11 Final Settlement**
- 1.1.12** The treated sewage passes through the biological filter bale to the final settlement stage where humus solids settle out and clarified liquor passes through the final zone. It is then discharged via the outlet, which is fitted with a v-notched weir or pump arrangement. This provides flow control and increases retention time throughout the wastewater system to a watercourse or soakaway.

## 1.2 Applications

	BTA1	BTA2	BTA3	BTA4	BTA5
Domestic Population Equivalent	Up to 6	Up to 9	Up to 12	Up to 18	Up to 25
Total BOD Loading	0.36kg/day	0.54 kg./day	0.72 kg./day	1.08 kg./day	1.50 kg./day
Maximum Flow	0.9m <sup>3</sup> /day	1.35m <sup>3</sup> /day	1.8m <sup>3</sup> /day	2.7m <sup>3</sup> /day	3.75m <sup>3</sup> /day
Peak Flow Rate	0.18 m <sup>3</sup> /hr	0.27 m <sup>3</sup> /hr	0.36 m <sup>3</sup> /hr	0.54 m <sup>3</sup> /hr	0.75 m <sup>3</sup> /hr

# 2 Installation Guidelines

## 2.1 Siting

- 2.1.1** It is essential that all surface water be segregated and excluded from entering the treatment plant.
- 2.1.2** We do not recommend a pumped feed to a Treatment plant without special reference to our Sales team.
- 2.1.3** Sink waste disposal units should **not** be used in conjunction with a Treatment plant. Please contact us for further guidance.
- 2.1.4** We do not recommend the use of air admittance valves with W.C systems connected to the plant. Tile vents should not be used as the sole drainage ventilation facility but if this cannot be avoided the

Unit should be independently ventilated. All inspection points within the drain system should be sealed to enable ventilation at high level.

- 2.1.5 If the plant is remote from buildings, ventilation of the inlet drain will be required.
- 2.1.6 In hard water areas a softener may be required, where one is fitted, the spent regenerant must be routed to a separate small soakaway.

## 2.2 Population Equivalent

- 2.2.1 Refers to normal family residents, some of whom have daytime occupations or schooling away from the house and includes overnight guests who may stay for periods of more than one night. Contact us for advice regarding non-standard situations.

## 2.3 Flow Balancing

- 2.3.1 Our package plant can deal with influent surges. The plant holds a large volume of treated effluent, which provides a significant dilution of influent surges, thereby minimizing any shock to treatment. It also has a surge control outlet arrangement.

## 2.4 Installation

- 2.4.1 These guideline instructions apply to the BTA1 -BTA5 Range of plant and should be read in conjunction with the section on Electrical Guidelines.
- 2.4.2 Before beginning the installation, the whole of these instructions must be read and understood. It is essential that you comply with all the given instructions.
- 2.4.3 Adherence to good Working Practices and the Health & Safety at Work act on site should be observed.
- 2.4.4 Prior to installation, check the tank for damage and always handle with care, avoiding heavy impact or contact with sharp objects.
- 2.4.5 On no account should the specified maximum drain invert depth be exceeded.
- 2.4.6 Never fill a freestanding tank with water or back fill an empty tank. Always fill the tank with water at the same time as the back fill material is placed. The water level inside the tank is to be maintained within 200mm of the concrete level during backfilling. This avoids the risk of flotation and minimizes the applied loads to the tank.
- 2.4.7 These instructions assume no more than pedestrian duty loadings will be applied to the final installation. Traffic or other heavy superimposed loads must not be transferred through the walls of the tank.
- 2.4.8 Select the unit location in accordance with building regulations, required distances from buildings, water supplies and irrigation systems.

## 2.5 Site Planning

- 2.5.1 The following points should be considered before installation of the equipment:
- 2.5.2 The discharge from a treatment plant may require the permission of the relevant Environmental Regulator and the complete installation, including the specified irrigation system should have Planning and Building Control approval.
- 2.5.3 In many cases, the effluent discharge is to an irrigation system. A soil porosity test should be carried out, please refer to current guidelines in place at plant's location e.g. or Building Regulations pt. H2. EN12566 part 2, or EPA Single house manual (Ireland).
- 2.5.4 There must be at least 1 metre of clear, level ground all around the unit to allow for routine servicing.
- 2.5.5 Wherever practicable, the unit should be installed as far as possible from any habitable building. Many Local Authorities will insist on a minimum distance of 15 metres from any building (7 metres Eire) and 10 metres (same distance for Eire) from any watercourse. Further information can be obtained through your Local Authority and in the Building Regulations in the UK and through the EPA in Eire.
- 2.5.6 Care should be taken not to place the unit in close proximity to any openings from the building.
- 2.5.7 Adequate access must be provided for routine de-sludging and maintenance. Usually, the unit should be sited within 30 metres of a hard standing area suitable for a vacuum tanker. Vehicles

should not be permitted within a distance equal to the depth of the unit unless suitable structural protection is provided to the installation.

- 2.5.8 Treatment units must be installed at a level, which will allow connection to the incoming drain and a free discharge at the system outlet (excepting units with an integral discharge pump). Effluent pumping stations are available to lift the discharge to a higher level and/or pump to remote discharge points. The location should not be subject to flooding.
- 2.5.9 If the unit has to be recessed, measures must be taken to ensure that it cannot be flooded by surface water run-off.
- 2.5.10 Where necessary the treatment unit should be fenced off or otherwise protected. Maintenance access must be maintained as above. Always keep the system locked. An open treatment plant must not be left alone
- 2.5.11 The drainage system connecting to the treatment unit must be adequately vented in accordance with the Building Regulations. The head of the drainage system should be connected to a stack pipe, open at high level, so as to draw foul air from the system and sited with consideration to prevailing wind direction. Tile vents & air admittance valves should not be used as the sole drainage ventilation facility, but if this cannot be avoided, the treatment unit should be independently ventilated. All inspection points within the drain system should be sealed so as to enable ventilation at high level.
- 2.5.12 Acceptable tolerance for installation of the Treatment Plant is +/- 20mm.
- 2.5.13 Our domestic treatment plants are structurally tested in accordance with EN 12566-3, which specifies structural stability testing using pea shingle backfill (worst case scenario), for both wet and dry sites, however due to rising groundwater conditions in GB and Ireland, we strongly recommend that a concrete backfill is used to install the product.
- 2.5.14 The Concrete Specification given below is not a site specific installation design.

<b>GENERAL CONCRETE SPECIFICATION IN ACCORDANCE WITH BS EN 206-1 (BS 8500-1)</b>		
TYPE OF MIX		(DC) DESIGN
PERMITTED TYPE OF CEMENT		BS 12 (OPC): BS 12 (RHPC): BS 4027 (SRPC)
PERMITTED TYPE OF AGGREGATE (coarse & fine)		BS 882
NOMINAL MAXIMUM SIZE OF AGGREGATE		20 mm
GRADES:	C25 /30 C25 /30 C16 /20	REINFORCED & ABOVE GROUND WITH HOLDING DOWN BOLTS REINFORCED (EG. FOR HIGH WATER TABLE) UNREINFORCED (NORMAL CONDITIONS)
MINIMUM CEMENT CONTENT	C30 C20	270 - 280 Kg/M <sup>3</sup> 220 - 230 Kg/M <sup>3</sup>
SLUMP CLASS		S1 (25mm)
RATE OF SAMPLING		READY MIX CONCRETE SHOULD BE SUPPLIED COMPLETE WITH APPROPRIATE DELIVERY TICKET IN ACCORDANCE WITH BS EN 12350-1
NOTE: STANDARD MIXES SHOULD NOT BE USED WHERE SULPHATES OR OTHER AGGRESSIVE CHEMICALS EXIST IN GROUND WATER		

- 2.5.15 Having excavated, if the base is excessively wet or unstable, lay 200mm of hard-core and line with polythene, prior to laying the 200mm level base of concrete. If necessary, make a sump hole to one corner of the excavation to accommodate a suction hose from a site pump, thereby keeping the excavation as dry as possible.
- 2.5.16 Lower the tank on to the levelled concrete, ensuring the top of the tank is completely level and that all connections line up. With the tank in position commence filling with water and at the same time back fill with concrete to just below the inlet/outlet levels. The water level inside the tank is to be maintained within 200mm of the concrete level during backfilling. It is important that these two operations are carried out simultaneously to avoid the risk of flotation. When back filling with concrete it is essential that the underside of the tank is evenly supported without voids.
- 2.5.17 Concrete backfill must be manually compacted - we do not recommend the use of vibrating lances. Make the inlet/outlet and air **duct** connection. Continue back filling with concrete to 50mm below the cover flange, completing the installation to ground level with free flowing soil.

**2.5.18** When concrete back filling, care should be taken not to concrete in cover fixings. A small amount of soil can be placed on the green curved top, but not on the access panel.

**2.6 Options**

**2.6.1** Where installations involve deep inverts on wet sites, concrete back fill in excess of that required for standard depth, should be applied in gentle pours with the tank fully ballasted. This operation should only be completed when the main backfill has set.

**2.6.2** These treatment plants are available with a gravity outlet or integral pump set (IPS). The installation procedure for the gravity version is the same, but the pumped outlet is suitable for MDPE pipe work at a shallower invert.

**2.7 Venting & Blower Housing**

**2.7.1** A 110mm diameter multipurpose air duct is located on the outlet side of the plant. A t-piece must be connected so the unit can be vented, and the air hose connected to the blower housing.

**2.7.2** Vent side of the T piece to be taken above ground and suitable vent mushroom fitted, cable and hose duct side of the T to be run back to the blower housing and sealed with expanding foam to avoid foul air recirculation into the plant

**2.7.3** Installer must ensure adequate venting is provided for the treatment plant to work efficiently.

**2.7.4** The ducting for the air hose must connect through an independent concrete base for blower housing location. The duct must be laid with long radius bends to enable the hose to be threaded through.

**2.7.5** The blower housing base slab should be located 3 to 13 metres from the outlet end of the plant such that the 15 metres of air hose provided is sufficient. The concrete base should be 150mm thick and must be large enough to accommodate the blower enclosure.

**2.7.6** Preferably the location for siting the blower should be shaded. Once the air hose is connected to the blower the duct through which it has entered should be sealed with spray foam.

**2.7.7** Where pumped outlets are included, electric cable is provided with the pump. The cable may need to be extended using a junction box to reach the blower housing, via the airline duct (depending on the distance the blower housing is from the treatment plant).

**2.7.8** Electrical installation from the supply should be made by a competent electrician in accordance with the appropriate regulations.

**2.7.9** It is essential that this treatment plants installation & set up is inspected correctly. This may be completed by the installer; however, it is recommended that the Pre-service Agreement Inspection be completed by us or an approved Service Engineer. This may be undertaken for a modest fee.

**2.8 Dimensions**

Model No.	Diameter mm	Depth mm
BTA1	1850	2200*
BTA2	1850	2700*
BTA3	1850	2700*
BTA4	2650	2100**
BTA5	2650	2600**

**2.8.1** \* Depths shown are for standard 1 metre invert unit. Additional 500mm to be added for units with 1.5 metre inverts.

\*\* Depths shown are for standard 0.875 metre invert unit. Additional 500mm to be added for units with 1.375 metre inverts.

**2.9 Self Help**

**2.9.1** In order to minimize the need for dealing with emergency situations we recommend that Treatment Plants have a Pre-service Agreement Inspection, then is regularly serviced by us or an approved Service Engineer.

**2.9.2** Provided that your plant is installed, operated correctly and serviced, you should not need to get into much – if any – self-help.

**2.9.3** However, some of the most likely question and answer situations are listed below. Firstly, any sewage treatment plant, if abused, can become a health hazard. If in any doubt, ask us or an approved Service Engineer.

**2.9.4** Blower Stopped:

**2.9.4.a** Check the unit is switched on, the incoming power supply circuit and fuse.

**2.9.5** Blower works but no water distribution inside the plant: Check hose connections.

**2.9.5.a** Check distributor heads.

**2.9.5.b** If the air lift pipes are suspected to be blocked, call for service.

**2.9.5.c** Check regulating valve is not closed.

**2.9.6** Plant Odour:

**2.9.6.a** Check blower working.

**2.9.6.b** If blower working, plant probably needs desludging.

**2.9.6.c** Check vent circuit is clear.

**2.9.6.d** Check that the air duct entering the blower housing has been sealed with foam.

**2.9.7** Plant Flooding.

**2.9.7.a** Check for blocked outlet system.

**2.9.7.b** If pumped outlet, check for pump operation, check floats and pump power supply.

**2.9.8 Do's and Don'ts**

**2.9.8.a** Do take out a service agreement and let the experts look after your plant.

**2.9.8.b** Do contact us for advice if you have any cause for concern.

**2.9.8.c** Don't pump feed the plant without reference to us.

**2.9.8.d** Don't use a waste disposal unit as you will be adding to the biological load, and your system may not be large enough to cope with the waste. If you are unsure, please refer to our sales team for guidance.

**2.9.8.e** Don't throw any medicines down the toilet.

**2.9.8.f** Don't empty large quantities of bleach or similar cleaning reagents into the system.

**2.9.8.g** Don't empty cooking oil or similar down the sink.

**2.9.8.h** Don't cover the plant with soil material or prevent access for service and desludging.

**2.9.8.i** Don't apply a hose or jet wash to the biological filter unless specifically advised to.

**2.9.8.j** Don't try to enter the plant. Make sure the plant is always locked

**2.9.8.k** Don't put sanitary towels, incontinence pads, nappies, tampons, or other non-biodegradable items down the toilet.

**2.9.8.l** Don't allow backwash from swimming pools or hot tubs to be discharged into the treatment plant.

**2.10 Blocked air lifts**

**2.10.1** Occasionally airlifts block. Usually this is as a result of non-biodegradable products entering the unit, such as sanitary items, rags, J clothes, plastic bags, etc. These items should not be allowed to enter the unit, as they will adversely affect the liquid distribution, the build-up of biomass, overall performance, and effectiveness of the unit.

**2.10.2** Sometimes blockages occur as a result of formation of calcium carbonate solids within the air lift pipe.

**2.10.3** Calcium carbonate is a gritty white to brown solid. The solid that forms within the pipe varies in colour and consistency depending on the nature of the sewage.



- 2.10.4 This type of blockage usually occurs because there is too much calcium present within the unit, the solid forms when the water chemistry is altered by the air bubbled through the pipe. This is a very unusual occurrence.
- 2.10.5 To prevent reoccurrence, you should
  - 2.10.5.a Ensure that no ground or surface water is allowed to enter the unit.
  - 2.10.5.b Check that where a softener is connected to the water supply of the property, that the regenerate chemicals, (which are high in calcium and magnesium salts) are not being fed into the unit.
  - 2.10.5.c Consider a softener to reduce the background level of calcium in the main feed supply.
- 2.10.6 When these blockages occur, the calcium carbonate formed is insoluble, and heavy. Within the pipe it is also sticky with other sewage solids. When wet the solids are not easily cleared from the pipe.
- 2.10.7 Should you have a recurring problem, please contact us and we will provide a spare air lift pipe.

## 2.11 Pre-service Agreement Inspection

- 2.11.1 We recommend that our Engineers or approved service provider should inspect the equipment. However, in situations where expediency is required for owner/installer to inspect, the following basic instructions may prove useful.
- 2.11.2 Check blower housing has been securely positioned and has been correctly wired to a suitable electrical supply, protected by an earth leakage circuit breaker, ensuring the equipment is correctly earthed. (refer to Installation Instructions). The electrical equipment must be inspected by a qualified Electrician and installed to the local Electricity Authority regulations.
- 2.11.3 Ensure the air hose has been securely connected to the hose adapter in the blower housing and the other end is connected to the manifold within the plant, ensuring that there are no sharp bends or kinks causing airflow restrictions.
- 2.11.4 Make sure construction debris is removed from within the plant.
- 2.11.5 It is essential that the Tank is filled with clean water to the outlet level. Before switching on the unit, ensure the air filter is correctly fitted and that the air intake is completely free of any obstructions. Switch on the unit. The airflow will activate the air lift pumps distributing the water over the biological filter. Check the centralisation of the distribution cones and adjust if necessary, to provide an even covering of the biological filters. Adjust the spray of distribution using the individual valves on airlines inside the unit.
- 2.11.6 Allow sewage to enter the plant as necessary and ensure that the blower is left running continuously. Biomass will build-up naturally over 4 -8 weeks and the plant should then treat sewage naturally.
- 2.11.7 To ensure the plant is functioning correctly and the final discharge is to the required standard, contact your service provider to arrange a Pre-service Agreement Inspection stating the original start-up date.
- 2.11.8 In order to get the best from your plant, we recommend that you contact us or one of our approved service providers to both carry out a Pre-service Agreement Inspection and service the plant. **This reduces the risk of non-compliance.** It also avoids unnecessary desludging and minimizes the cost of emergency call out visits.

## Taken from 'Klargester's Terms & Conditions of Sale'

### 2.12 Warranty

- 2.12.1 The company will replace or, at its option, properly repair without charge any goods which are found to be defective and which cause failure in normal circumstances of use **within a period of twelve months from the date of delivery.**
- 2.12.2 This warranty is conditional upon:
  - 2.12.3 (a) the Buyer notifying the Company of any claim within Seven days of the failure becoming discernible.
    - (b) the Company being allowed a reasonable opportunity to inspect the goods so as to confirm that they are defective.
    - (c) the goods not having been modified, mishandled or misused and being used strictly in accordance with any relevant instructions issued by the Company.

- 2.12.4 The Company's liability under this Clause is limited to the repair or replacement of the defective goods, and does not cover costs of transport, installation or associated site costs, if applicable.
- 2.12.5 The Company's liability to replace or repair the goods is in lieu of and excludes all other warranties and conditions, and in particular (but without limitation) the Company shall have no liability of any kind for consequential loss or damage.
- 2.12.6 For any further advice, please contact our Service & Warranty department.
- 2.12.7 A warranty form is included in this package, to register your unit for warranty. Please complete ALL sections of the form and return it at your earliest convenience.
- 2.12.8 Also within this manual is a **Notice**, describing the necessary maintenance for the plant. This should be fixed within the building.

## 3 Electrical Installation

### 3.1 General Electrical Installation Information

- 3.1.1 It is imperative that the electrical installation of this equipment is entrusted to a competent qualified electrician working to the latest IEE regulations.
- 3.1.2 It is not possible to state a specific installation configuration that would suit all sites. The selection of current protection devices must remain the responsibility of the installer who should select a suitable cable and current overload protection, taking into account the distance from the power source to the unit and any other relevant factors. (In many cases steel wire armoured (SWA) cable, minimum 1.5 sq mm will be suitable).
- 3.1.3 When installing the electrical supply to the unit, the following points should be considered:
  - 3.1.3.a The electric power supply to the tank should be by means of a dedicated circuit with isolation and protection devices consistent with the requirements for fixed equipment and in accordance with the latest regulations of the Institute of Electrical Engineers.
  - 3.1.3.b This power supply should be independent of all other household protection devices other than the supply authority's main fuse and that provided specifically for the power supply. In particular, earth leakage devices provided for normal domestic protection must not form part of the supply circuit to the tank.
  - 3.1.3.c An earth leakage circuit breaker should be incorporated in the supply to the unit. A device with 30mA minimum trip current is recommended.

### 3.2 Isolator - L Range

- 3.2.1 The Isolator with power failure light (in the blower box) can be mounted externally at a point where it is easily visible from the property.
- 3.2.2 The power supply cable should connect to the IP65 rated isolator socket mounted externally (see sales drawing). Any terminal shrouds removed during the connection of cable cores must be replaced afterwards. A separate duct or conduit should be provided by others.

3.2.3 Isolator Wiring Diagram - Gravity System:

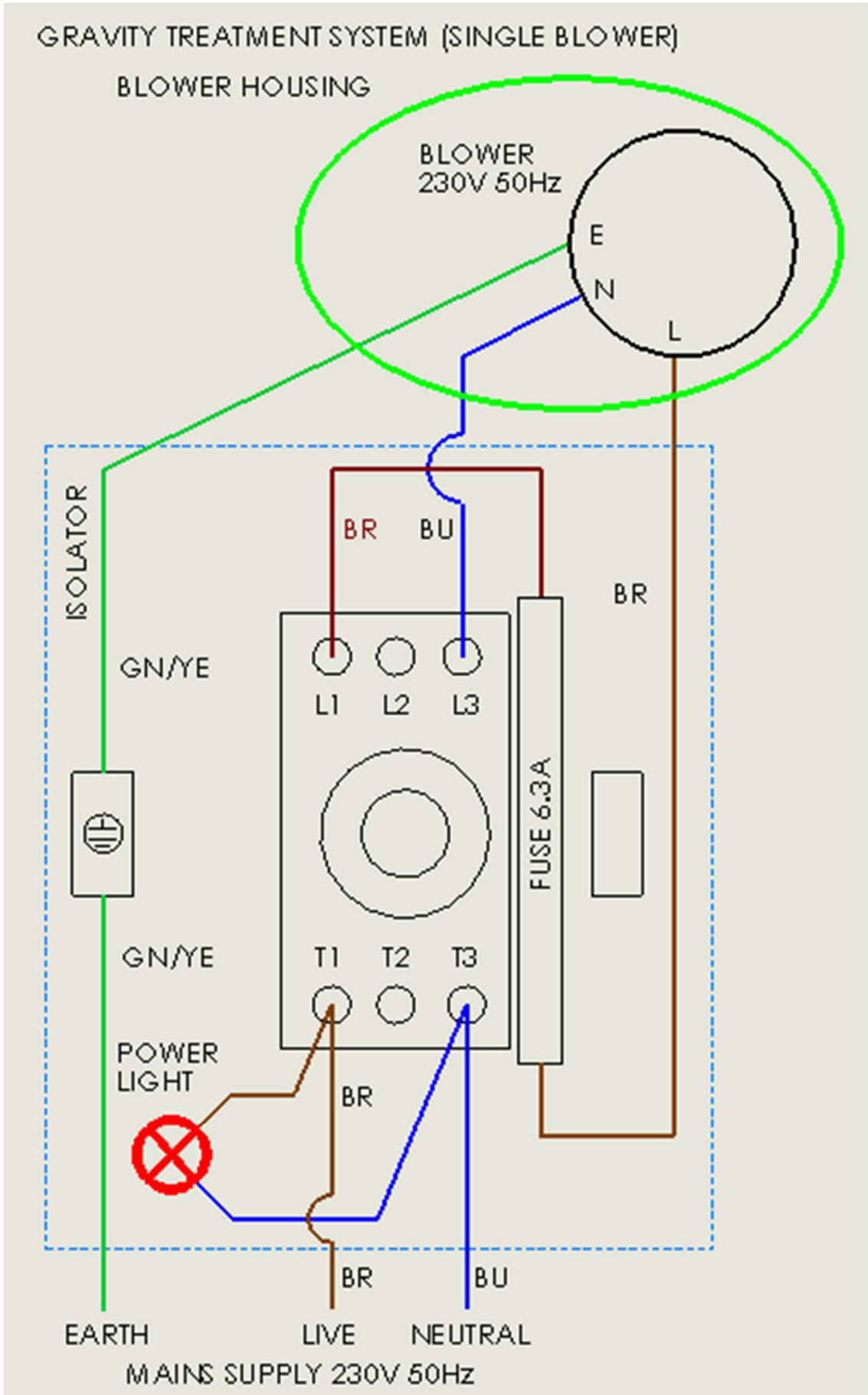

3.2.3.a Isolator Wiring Diagram - IPS System:

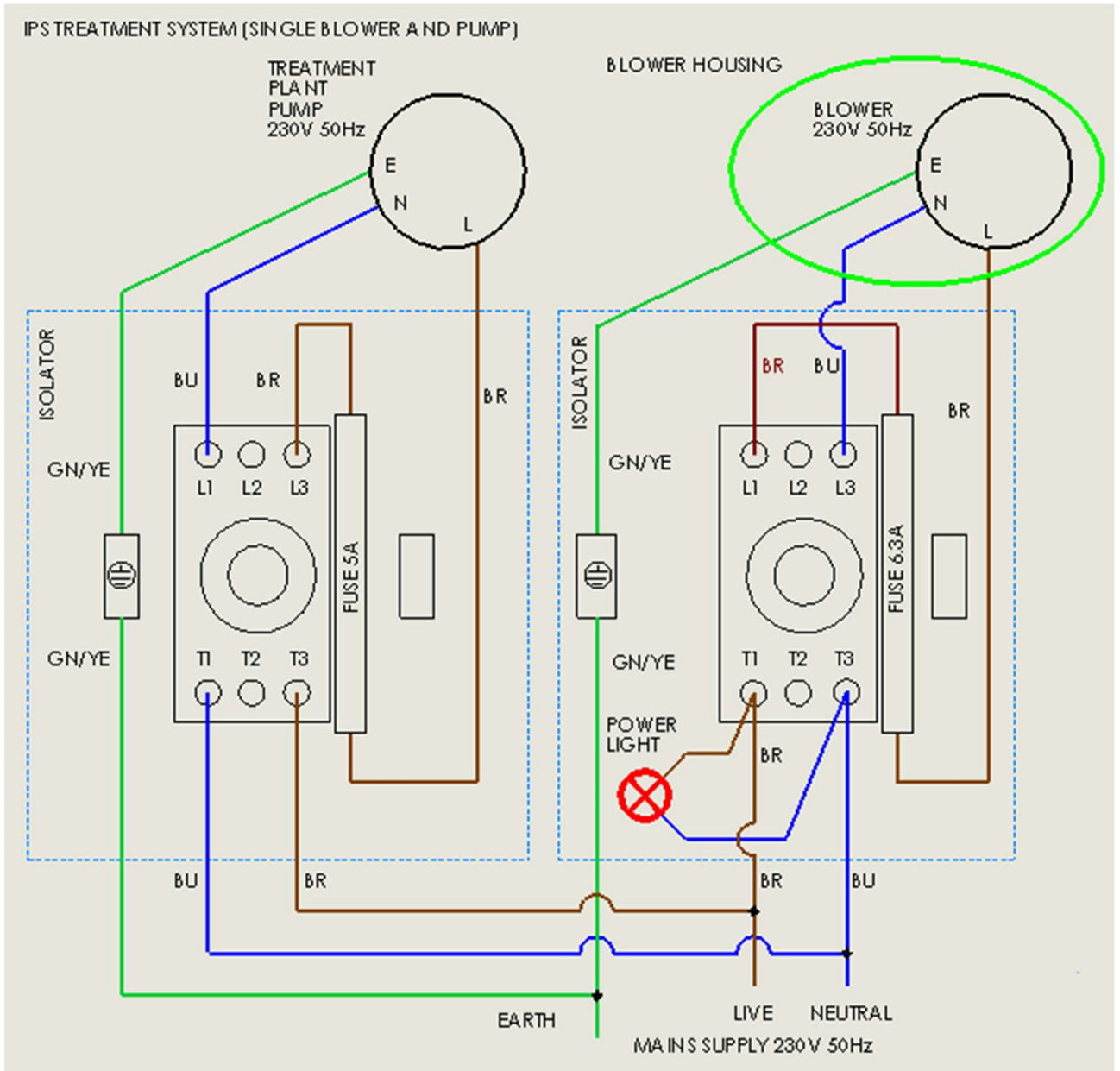

### 3.3 Control Panel - P Range (Premium)

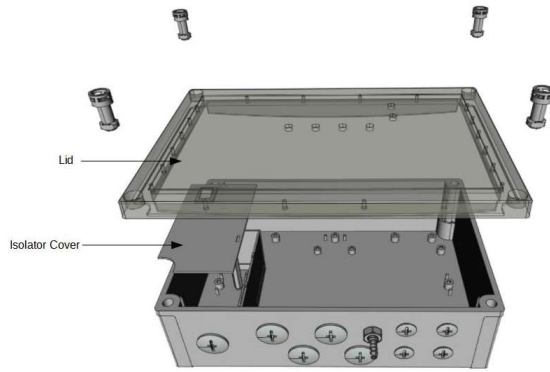

Figure 1: 1002510 Lid & Cover

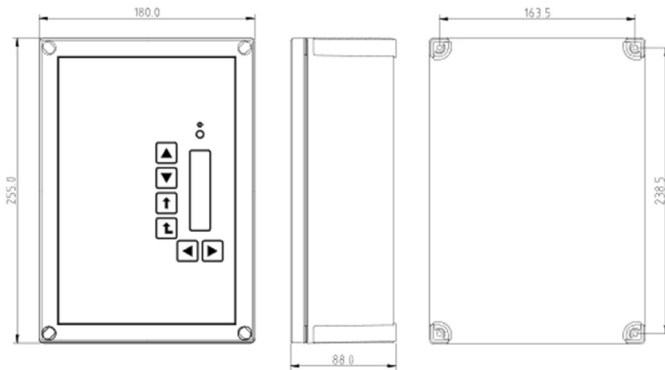

Figure 2: Enclosure & Mounting Dimensions

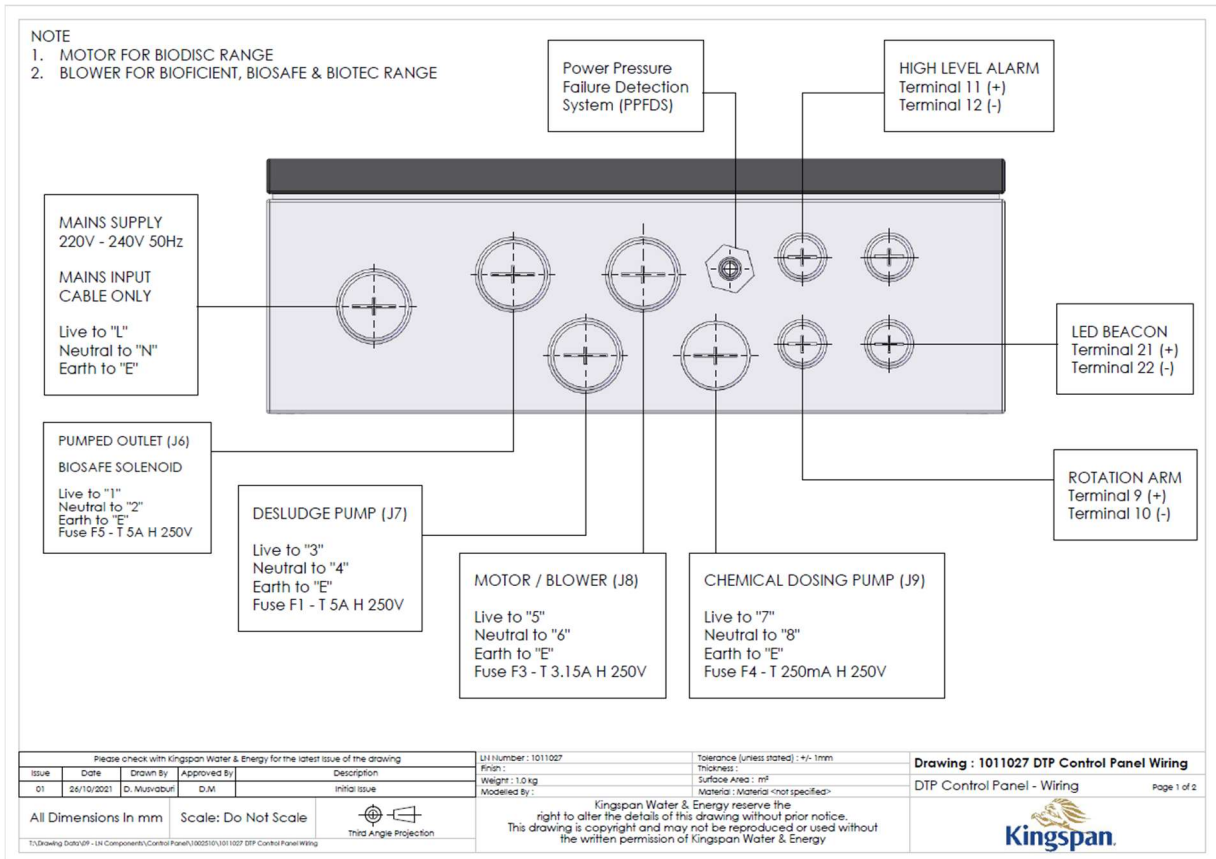

Figure 3: Control Panel Wiring (1)

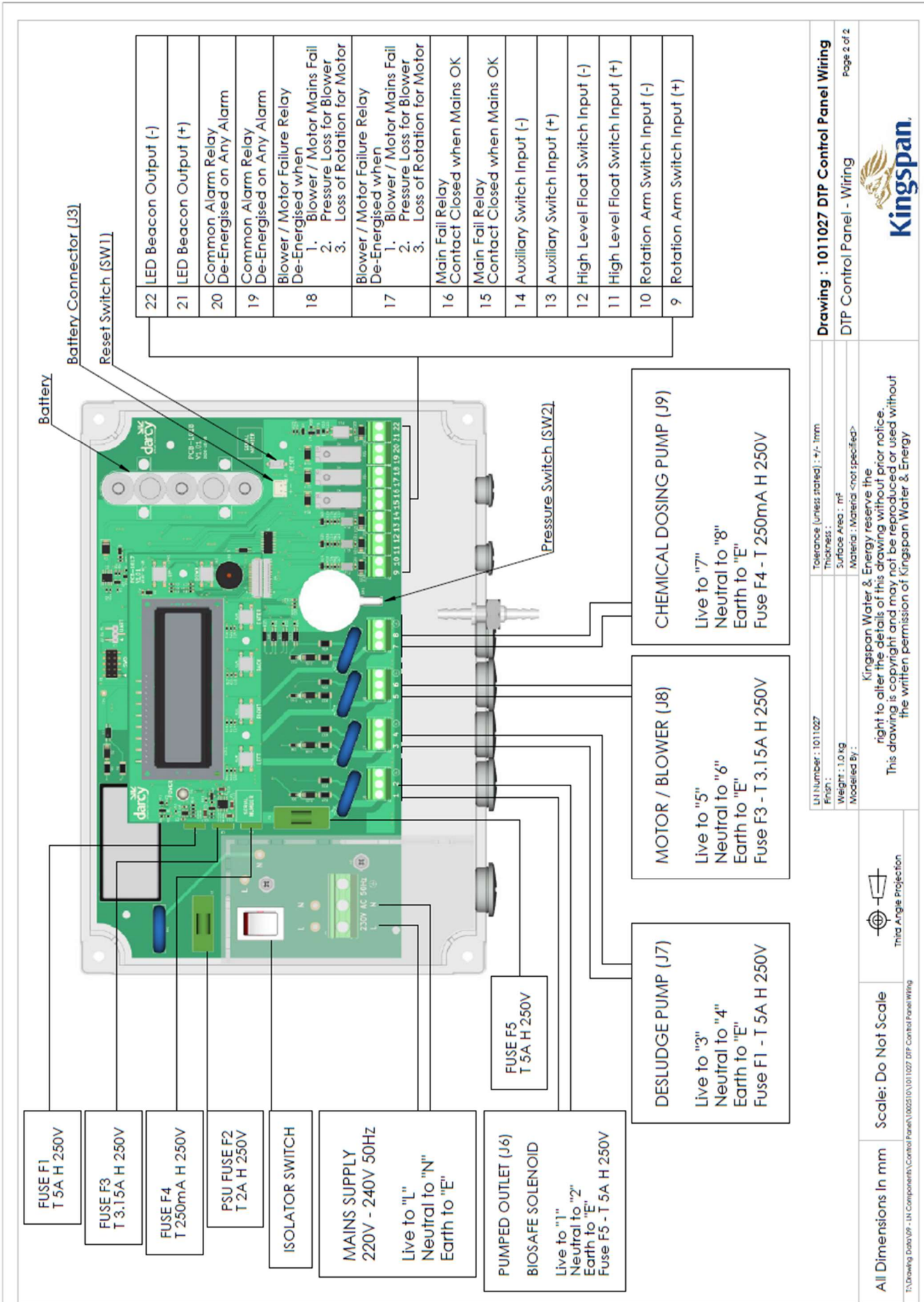

Figure 4: DTP Control Panel Wiring (2)

**Drawing : 1011027 DTP Control Panel Wiring**  
DTP Control Panel - Wiring Page 2 of 2

Kingspan

LIJ Number : 1011027  
Tolerance (unless stated) : +/- .1mm  
Finish :  
Surface Area : m<sup>2</sup>  
Weight : 1.0 kg  
Modelled By :  
Material : Material <not specified>

Scale: Do Not Scale

All Dimensions In mm

Third Angle Projection

Kingspan Water & Energy reserve the right to alter the details of this drawing without prior notice. This drawing is copyright and may not be reproduced or used without the written permission of Kingspan Water & Energy

T:\Drawing\Subs\05 - 101 Components\Control Panel\1002510\1011027 DTP Control Panel Wiring

### 3.3.1 General Installation

The control panel must not be adjacent to the plant. It can be mounted in the blower housing (supplied with Biotec), wall mounted or fixed to the mounting frame (available separately). It should be positioned so it cannot be reached by someone standing in or on the unit. It would be advisable to situate the control panel and beacon in a frequently viewed position, so if a fault alarm appears it will be seen.

### 3.3.2 Mounting Frame Installation (where applicable)

Set the frame legs in a concrete base, minimum 250mm thick and prop the frame to prevent movement until the concrete has set.

Allow 350mm minimum clearance from finished ground level to the bottom of the panel.

### 3.3.3 Retrofit of Control Panel

This Panel can replace the Kingspan Panel (P.No.010086 - Green Panel). The existing beacon (P.No.010332) will have to be replaced with the New Beacon (P.No.1009254) which is provided with Control panel (P.No.1002510) as it is not compatible with the new control panel.

### 3.3.4 Installation of Integral Discharge Pump (where applicable)

Using a suitable M20 gland, feed the pump power cable through Gland Hole and terminate to connections 1 & 2 (J6) according Figure 1 & Figure 4

### 3.3.5 Installation of High-Level Alarm – HLA (where applicable)

Fix the black plastic bracket to the side wall of the baffle (the exact position is on the drawing included with the HLA kit). Secure the float cable in the cable gland as shown on the drawing in the HLA kit. Pull the float cable through any installed ducting into the blower housing. Complete wiring according to Figure 3 & Figure 4

### 3.3.6 Beacon units - P.No.1009254 (where applicable)

The Beacons provides an external visual indication which is used to indicate Failure & Service Reminders and may be included in the Power and Pressure Failure Detection System (PPFDS). The beacon is provided with a 5m cable which can be extended to 30m. As supplied, the unit is protected against rain to IP65 and is supplied ready to mount on a suitable surface. Complete wiring according to Figure 3 & Figure 4

This unit is designed to be simple to install and safe in operation. Any modification may adversely affect its weather resistance in operation. If in any doubt, please consult us for advice. This is a sealed unit and not serviceable.

### 3.3.7 Installation of High-Level Alarm – HLA (where applicable)

Fix the black plastic bracket to the side wall of the baffle (the exact position is on the drawing included with the HLA kit). Secure the float cable in the cable gland as shown on the drawing in the HLA kit. Pull the float cable through any installed ducting into the blower housing. Complete wiring according to Figure 3 & Figure 4

### 3.3.8 Power & Pressure Failure Detection System – PPFDS (where applicable)

The panel is designed to be used in conjunction with the Beacon unit to provide warning of either loss of power or air pressure failure.

For panels mounted outside the blower housing, additional tubing can be purchased, contact your local sales team for details. The panel can be mounted up to 30m away from the blower with no effect on the performance of the pressure failure detection system.

To prevent damage to the PPFDS hole is fitted with a nylon bolt and nut. If the PPFDS is to be used, replace the bolt with the air inlet bulkhead fitting supplied inside the control unit. A short length of 4mm silicone tubing and a cable tie is also supplied. Connect the tubing from the bulkhead fitting to the **Top Port** of the

pressure switch, SW2, see Figure 5: Pressure switch tubing .Tie the cable tie on the pressure switch to prevent the tubing slipping off as it is not barbed.

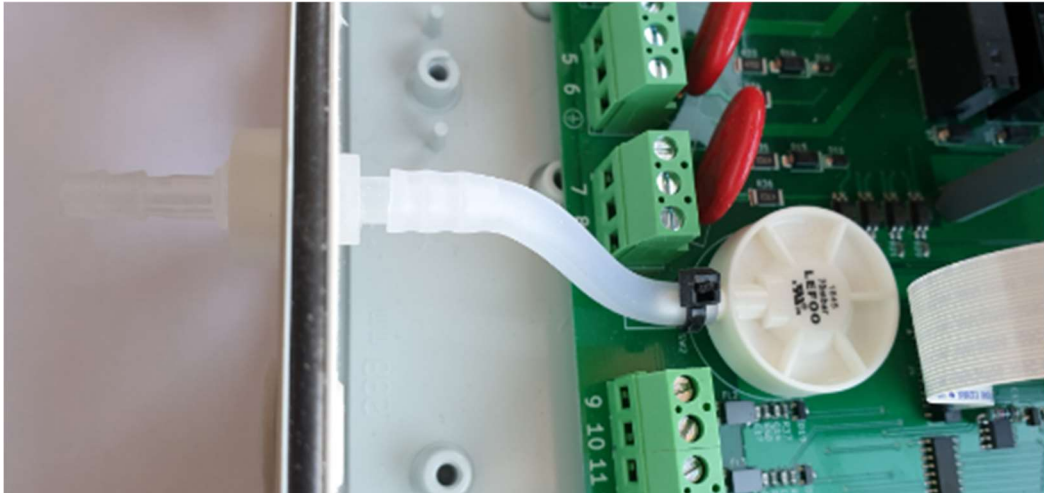

Figure 5: Pressure switch tubing

### 3.3.9 Completing the Installation

Complete all wiring according to Figure 4. Plug the lead from the battery into the small white socket below the battery on the PCB marked J3. After finishing wiring, replace the isolator cover and screw. Turn the mains supply on at the source. Turn on the panel using the isolation switch. It should now be illuminated **RED**. The display should now show text.

Replace the top cover and screws carefully so as not to damage buttons, ensuring the lid is fixed correctly. Follow Guide in Section 3.3.11 Configuration Programming to enable programming.

### 3.3.10 Ancillary Equipment

Ancillary items should be installed in accordance with the Installation Guide supplied e.g. Sewage Pump Station/Effluent Pump Station/Effluent Sample Chamber.

### 3.3.11 Configuration Programming

#### 3.3.11.a Start Up

When the control unit is powered up for the first time, the display will prompt for the country to be selected.



Figure 6: Keys for Configuration

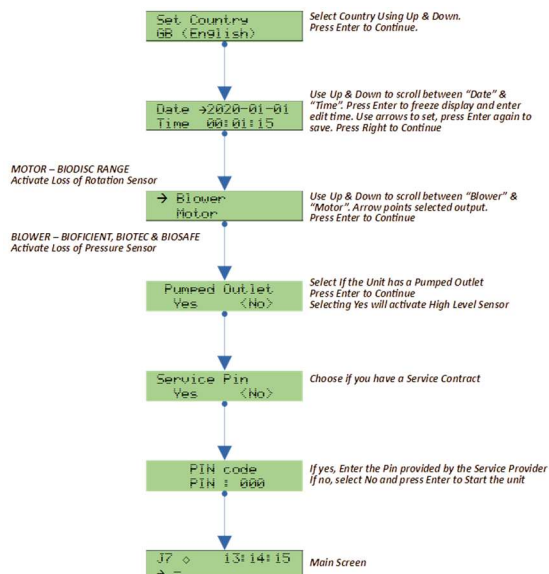

Figure 7: Initialisation



### 3.3.11.b Detailed Operation

Once the initialisation is complete the operating screen will appear as follow. Page 1 to 6 can be navigated using ◀ & ▶ key.

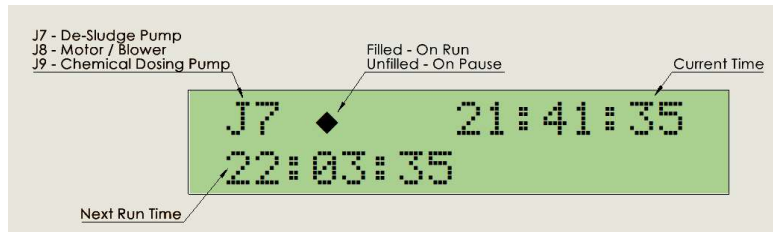

Figure 8: Main Screen Page 1

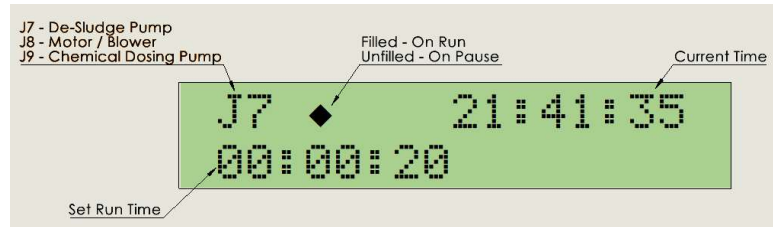

Figure 9: Main Screen Page 2

Page 3 to 6 are like the above, for Motor / Blower & Chemical Dosing Pump.

Press down key to show the date and time when the next service is due.

If only the pin is used this will show an upcoming date. If not activated, this will show a 2021 date.

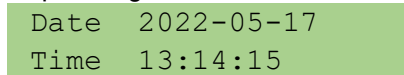

Figure 10: Next Service Due

Press down arrow again to return to the initial screen showing the now activation time.

### 3.3.11.c Alarms

The conditions shown below cause an alarm message to appear on the display, the beeper sounds, the beacon flashes, and the common alarm telemetry relay is de-energised. Some alarm conditions are recorded in the event log, along with the date and time. The display will cycle through messages if multiple alarms exist at the same time. The alarm message(s) will disappear when the alarm condition(s) have been cleared.

- Mains failure
- Low battery
- Loss of rotation
- High level float probe
- Auxiliary input
- Blower pressure
- Pumped outlet fuse
- De-sludge pump fuse
- Motor/blower fuse
- Chemical dosing pump fuse
- Service due

The beeper can be muted by pressing the '←' button. The beeper will sound again after **SIX HOURS** if any alarm condition still exists.

**3.3.11.d Service**

**3.3.11.d.1 Service Due Date**

The Service Due Date can be viewed on main screen by pressing '▼' until the date and time are shown.

**3.3.11.d.2 Service alarm**

If the service alarm is activated using PIN, service alarm is reported on the display every 360 days, by default. The beacon flashes and message "Contact Service Provider" pops every few seconds. The beacon will stop flashing by pressing the '←' button. A service symbol appears on the screen until the next service is done & a contract renewed.

**3.3.11.d.3 Telemetry Relays Outputs**

There are three volt-free contacts available for alarm reporting to external systems. Follow Guide on **Error! Reference source not found.** for wiring.

**3.3.11.d.4 Menu**

Menu allows timetable entries to be edited, event log to be viewed, date/time, settings, service, battery and setting factory defaults.

This menu is intended for use by installation & Service engineers only.

The menu is entered by simultaneously pressing then releasing the three buttons '◀', '▶' & '▲'.

**On entry to the menu all outputs and telemetry relays are switched off.**

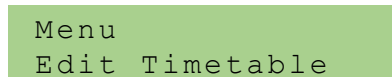

Figure 11: Menu - Edit Timetable

The current option is shown on the bottom row and is selected by '▲' and '▼'. Press the '←' button to proceed with the current option.

**Pressing '←' or '◀' will return to normal operation.**

**3.3.11.d.5 Edit Timetables**

Use '◀' and '▶' to select between **Start**, **Stop**, **Run**, and **Pause** times for the current timetable entry. Use the '←' button to edit the entry. A flashing cursor will appear over the first digit of the hour. Use '▲' and '▼' to increment and decrement the digit, respectively. Use '◀' and '▶' to move to the previous or next digit in the time, respectively. Once the entry has been edited, press the '←' button to save changes and exit edit mode, or press the '←' button to cancel changes and exit edit mode. Use '←' or '◀' to return to the menu.

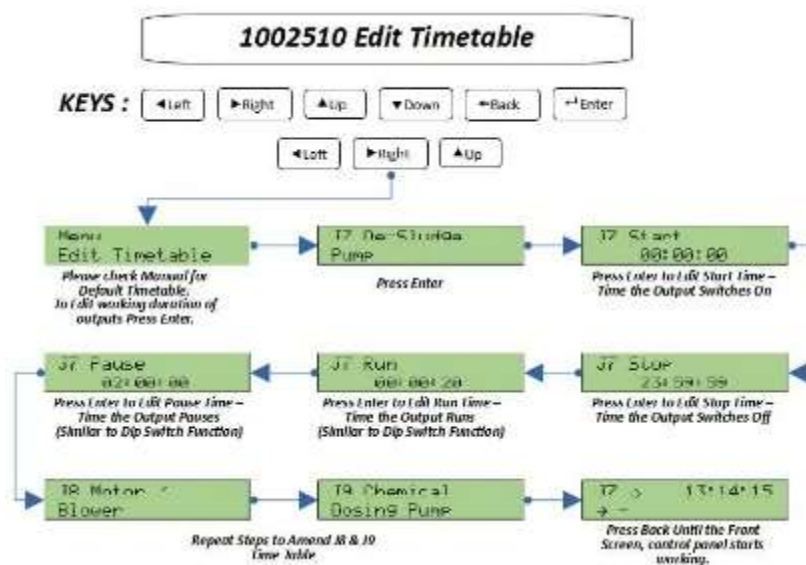

Figure 12: Editing Timetable

**3.3.11.d.6 Event Log**

This option shows the last ten alarm conditions that have occurred along with the date/time. An event is also recorded when the alarm clears. The message “Log is Empty” will appear if no alarms have been recorded yet.

Use ‘▲’ and ‘▼’ to move through the events. Use ‘◀’ and ‘▶’ to alternate between the event message and the date/time the event occurred.

Use ‘←’ to return to the main menu.

**3.3.11.d.7 Set Date & Time**

This option allows the current date and time to be set in the 24-hour format. The display will show:

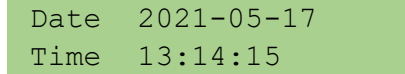

Figure 13: Date & Time

**3.3.11.d.8 Settings**

Setting can be used to amend inputs such as Loss of Rotation or Loss of Pressure, High Level Alarm & Beeper. LOR or LOP & High-Level Alarm will be enabled / disabled during the initialisation.

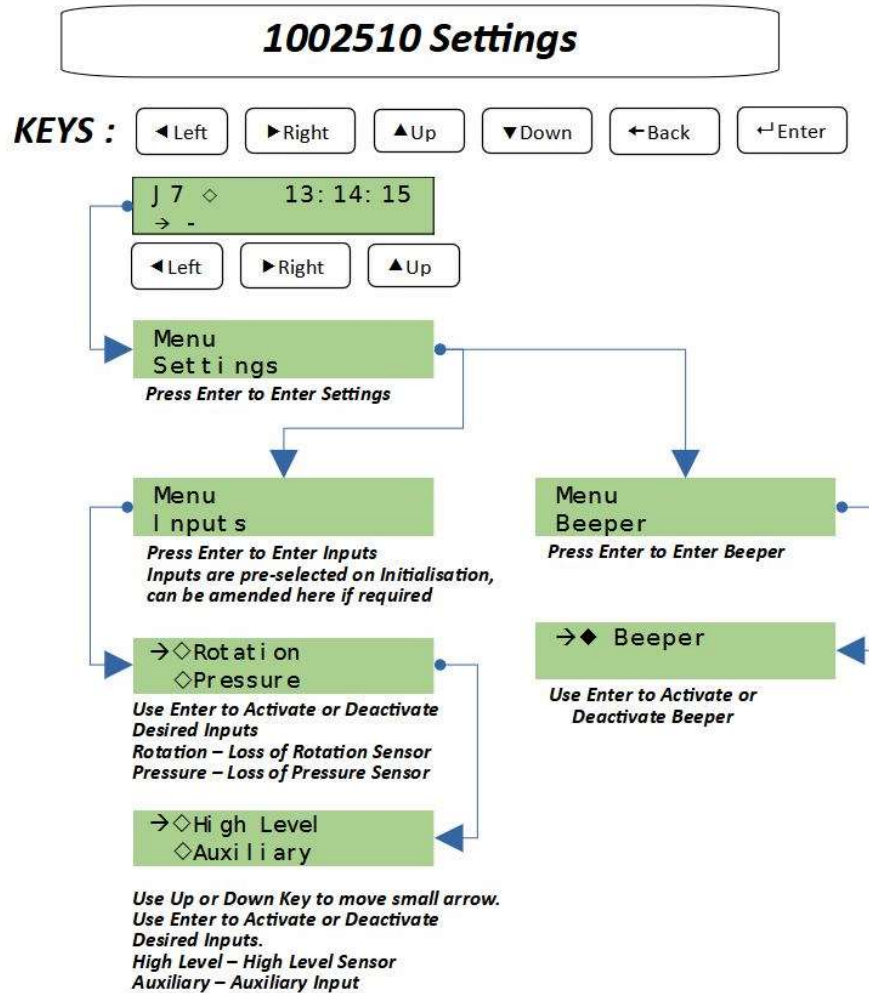

Figure 14: Settings

**3.3.11.d.9 Service**

This allows setting the interval between which service alarms occur. The default is 360 days.

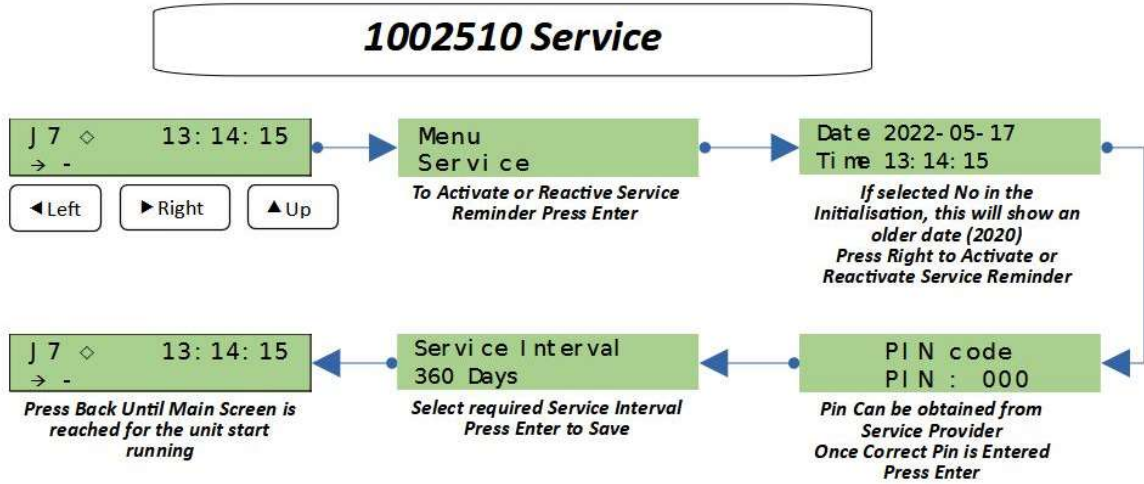

Figure 15: Service

**3.3.11.d.10 Battery**

This displays the battery charger status. The display shows “Not Charging” when mains power is absent. The charging countdown is paused.

“Standard charge” is displayed when the control unit first has power applied or the internal reset switch is pressed. This last for 16 hours and a countdown is shown on the display. “Intelligent Charge” is displayed when power is interrupted and shows the amount of time until the battery is fully charged. “Trickle Charge” indicates that the unit is fully charged and maintaining the battery.

**3.3.11.d.11 Factory Defaults**

This option allows the control unit to be set back to the defaults as they were when the unit left the factory. The following will be reset with defaults shown in brackets.

- Unit not activated
- Country (GB & IRE (Eng.))
- Timetables (see Motor / Blower Default Timetables 3.3.11.d.12 )
- Event log (empty log)
- Service interval (360 days)
- Inputs (disabled)
- Blower/motor (blower)

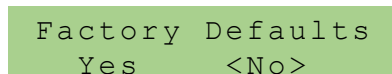
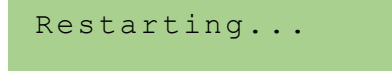

Figure 16: Factory Default

Initially the “No” option will be highlighted to prevent accidentally setting factory defaults if this was not intended.

Use the ‘◀’ button to move to the Yes option and press the ‘↵’ button to confirm. The display will show:



A few seconds later the unit will restart and prompt for the country to be selected. See 3.3.11.a Start Up

**3.3.11.d.12 Motor / Blower Default Timetables**

Start Time (Time of Day where Unit is started)	:	00:00:00
Stop Time (Time of Day where Unit is stopped)	:	23:59:59
Run Time (Time for the components to Run)	:	23:59:59 (24 hours)
Pause Time (Time for the components to Stop)	:	00:00:00 (0 minutes)

**4 Operations****4.1 Standard Rate Treatment Plants**

Model No.	Litres	Gallons
BTA1	2,220	500
BTA2	3,540	800
BTA3	3,540	800
BTA4	4,170	920
BTA5	5.870	1290

**4.2 General Maintenance**

- 4.2.1** Sewage Treatment installations will only perform as well as they are maintained. The best way to achieve this is to arrange a service agreement with us or an approved Service Engineer (see below). There will always be situations when a little self-help may be sufficient to avoid call out and we describe here some basic checks, which may prove useful.
- 4.2.2** Firstly, keep children and pets away from the plant and always wear rubber gloves when inspecting the unit. Never try to climb into the plant.
- 4.2.3** If in doubt, ask us or an approved Service Engineer for advice. One of the things that will come from routine maintenance is evaluation of the desludging interval.
- 4.2.4** Having confirmed that the sludge situation is under control, the following basic checks can be made.
- 4.2.5** Check that the spray is covering the rectangular bale. This can be adjusted by the plastic valve attached to the air hose inside the plant.
- 4.2.6** Ensure that the airlift in the centre of the bale is not blocked, as this will also affect the spray pattern.
- 4.2.7** Where pumped outlets are included, check the pump operation, check floats and check pump power supply to the plant.

**4.3 Emptying and Desludging**

- 4.3.1** All biological treatment plants produce a surplus of sludge, which from time to time have to be removed in order to maintain process efficiency. Applications on purely domestic feed may only require desludging 6-12 months, whereas more heavily loaded installations may require desludging at least 6-9 months.
- 4.3.2** Desludging must be carried out by a reputable company who may be located by reference to Yellow Pages, your District Council or from your local Water Authority. We may be able to help you with suggesting an emptying contractor. When ordering a tanker for any desludging you will have to state the capacity of the unit to enable the correct size tanker to be scheduled (see 0).

**4.4 Emptying and Desludging Procedure**

- 4.4.1** Turn off the unit. First ensure that the hose is placed on the inlet side of the unit, always empty the tank ensuring equilibrium in water levels.
- 4.4.2** Reduce the water level by about 300mm then place the hose in the outlet side of the tank, also reducing the water level by 300mm. Continue with this process until the tank is completely empty.
- 4.4.3** Make sure that the hose and end fitting are, as far as practical, kept away from the baffles whilst raising and lowering.

- 4.4.4** The hose and end fitting must be positioned to draw from the very bottom to collect accumulated settled sledges. Make sure construction debris is removed from within the plant.
- 4.4.5** Take care not to blow back the wastewater into the treatment plant when lifting the hose from one compartment to another one or removing it from the plant.
- 4.4.6** Whilst pumping out, check the other compartments to make sure that the water level drops at the same rate. At no time should the difference in water level either side of the screen exceed 300mm. As far as is practical, remove traces of sludge accumulation on the walls and bottom of the chamber.
- 4.4.7** Check for the presence of any residual solids in the bottom of the final settlement zone, i.e. the last tank compartment, and if there are any present, remove them.
- 4.4.8** If a clean water hose is available, hose down any residual solids from the interior of the tank. Do not hose off the biomass from the media unless it is blocked.
- 4.4.9** The tank should be refilled as speedily as is practical using mains supply water. Refill the tank evenly from both sides of the screen, therefore establishing a constant equilibrium. It is advisable to leave the air blowers off until normal water level has been achieved.



## BTA1 – BTA5 UK

**The foul drainage from this property discharges into a package treatment works.**

Maintenance is required, the frequency of which depends upon the model installed, its use and application. Please consult your Operation & Maintenance Manual.

- \* When operating at the normal daily load, emptying should take place every 6-12 months, whereas more heavily loaded installations may require desludging at least 6-9 months.

Maintenance and Desludging should be carried out by the owner in accordance with the Manufactures instructions.

**THE OWNER OF THE PROPERTY IS LEGALLY RESPONSIBLE FOR ENSURING THAT THE SYSTEM DOES NOT CAUSE POLLUTION, A HEALTH HAZARD OR A NUISANCE.**

We recommend that a separate log is kept of all maintenance and service visits, the log should detail the date and any action taken, e.g. Regular maintenance service, breakdown visit, desludge volume removed, parts replaced.

**This notice should be fixed by the owner within the building alerting current and future owners to the maintenance requirement.**

**(Building regulation H2 (1.57))**

Please contact Sales on 01296 633 033 or Service Department UK on 03332 406 868 to arrange a maintenance service or to request replacement operating instructions. It would be helpful if you provide your equipment serial number.