

CUBETA DE RETENCIÓN

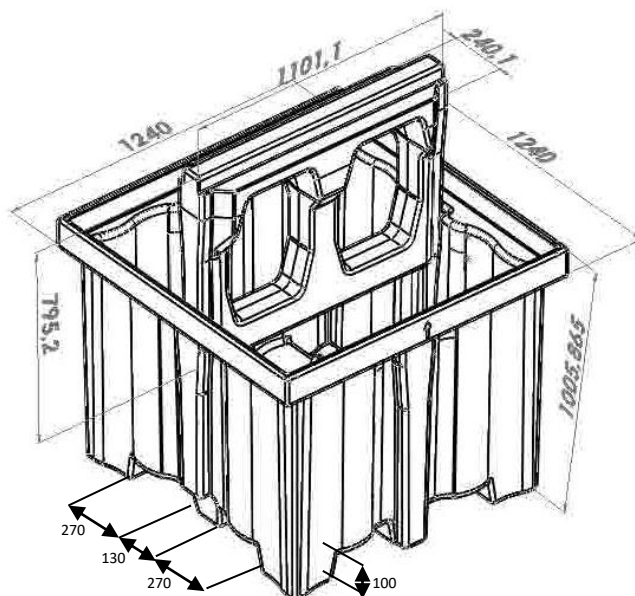

Nota: Este manual de servicio forma parte integrante del producto y tiene que estar a disposición del operador en todo momento, y debe ser leído y entendido antes de su uso.

DIMENSIONES

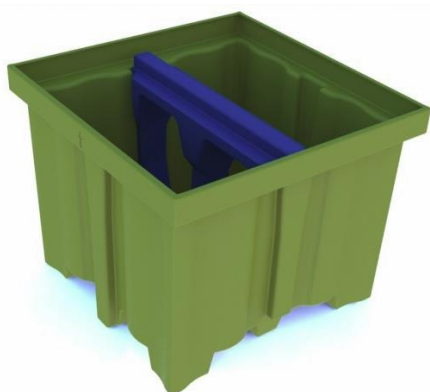

FASES DE MONTAJE

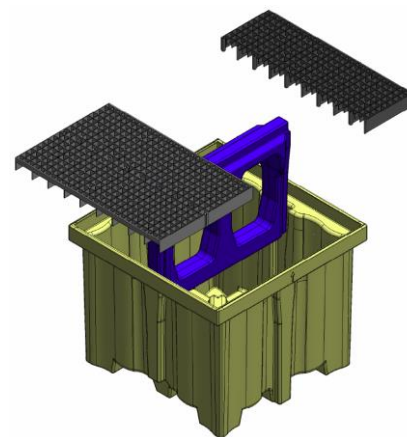
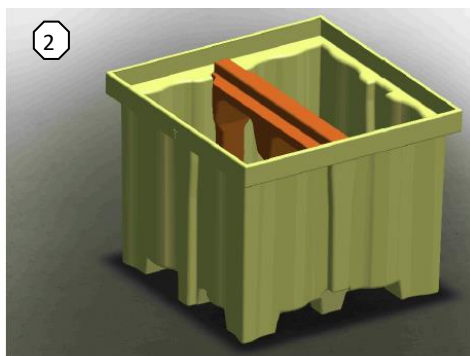
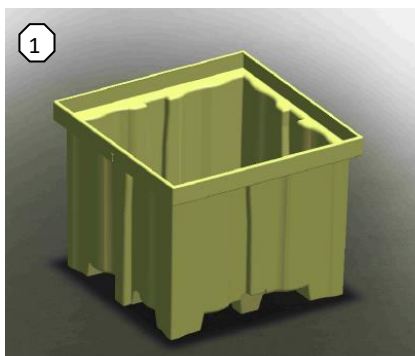

Grapa Unión Trames

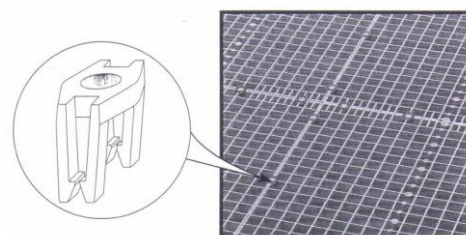
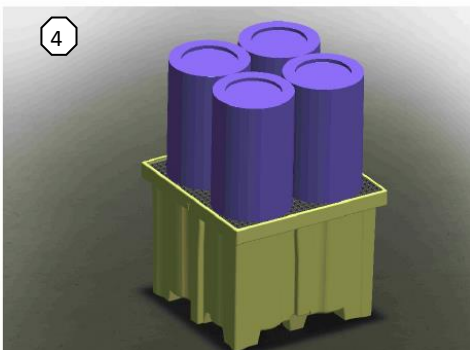
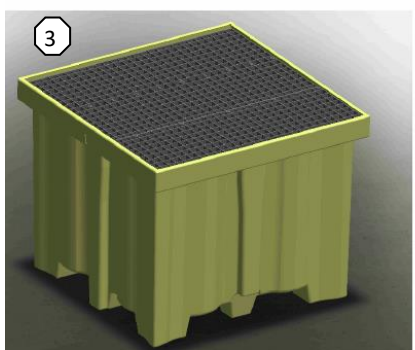

CUBETA DERRAME GRANDE

PESO CUBETA DERRAME GRANDE + TRAMES	63 Kg
PESO PIEZA INTERMEDIA	13 Kg
MATERIAL	HDPE
CAPACIDAD	1.016 Litros
CAPACIDAD MAXIMA	2.200 Kg
LOGO NOVODINAMICA	SI
GRABADO FECHADOR	SI
REFERENCIA	3063

COMPATIBILIDAD DEL POLIETILENO

Utilizada para determinar la compatibilidad de nuestros productos de polietileno con los productos químicos

LETRAS

L Los productos son aptos para el contacto repetido o prolongado con esas sustancias, en las condiciones especificadas.

S Estas sustancias pueden afectar negativamente a los productos de polietileno. Puede ser apto para el contacto intermitente, sin embargo, se pueden causar cierto deterioro en las propiedades del material.

N Estas sustancias agresivas atacan al polietileno o los vapores son incompatibles con el polietileno. No deben usarse con los contenedores de polietileno.

A

Acetaldehyde (40%)	L	Acetaldehyde (40%)	L	Acetamide	L
Acetic Acid (50%)	L	Acetic Acid Anhydride	S	Acetic Ether	S
Acetone	L	Acetylene Tetrabromide	S	Acrylic Emulsions	S
Acrylonitrile	L	Adipic Acid	L	Aliphatic Hydrocarbons (Hexane, Octane, Hexene, Octane, Etc.)	L
Allyl Alcohol (96%)	L	Alum (Aqueous Solutions)	L	Aluminum Chloride (20%)	L
Aluminum Fluoride	L	Aluminum Hydrogen Solution (10%)	L	Aluminum Hydroxide	L
Alums (All Types)	L	Ammonia (Anhydrous)	L	Ammonia (Aqueous)	L
Ammonia (100% Dry Gas)	L	Ammonium Salts	L	Ammonium Acetate	L
Ammonium Bifluoride	L	Ammonium Carbonate 50%	L	Ammonium Chloride	L
Ammonium Hydrogen Fluoride (50%)	L	Ammonium Hydroxide	L	Ammonium Metaphosphate Sat'd	L
Ammonium Nitrate (10%)	L	Ammonium Nitrate Sat'd	L	Ammonium Persulfate Sat'd	L
Ammonium Phosphate	L	Ammonium Sulfate (10%)	L	Ammonium Sulfate Sat'd	L
Ammonium sulfide Sat'd	L	Ammonium Thiocyanate Sat'd	L	Amyl Acetate	L
Amyl Alcohol (100%)	L	Amyl Chloride	N	Aniline (100%)	S
Aniline Hydrochloride	S	Animal Fats	L	Anti-Freeze	L
Antimony Salts	L	Antimony Trichloride 90%	L	Aqua Regia	N
Aqueous Salt Solutions (NaCl)	L	Aqueous Alkalies (NaOH)	L	Arsenic Acid	L
Arsenic Salts	L				

B

Barium Salts	L	Barium Carbonate	L	Barium Chloride	L
Barium Cyanide	L	Barium Hydroxide	L	Barium Nitrate	L
Barium Sulfate	L	Barium Sulfide	L	Battery Fluid Acid	S
Beef Tallow Emulsion, Sulfonated	L	Beer	L	Benzaldehyde,	L
Benzene	L	Benzene Sulfonic Acid	S	Benzoic Acid	L
Benzyl Alcohol	L	Benzyl Chloroformate	L	Bismuth Salts	L
Bleach Lye (10%)	S	Black Liquor	L	Borax Cold Sat'd	L
Boric Acid Dilute	L	Boric Acid Conc.	L	Bromine, Liquid	N
Bromine, Water	N	Bromobenzene	N	Bromoform	N
Butadiene	L	Butane	L	Butanediol (100%)	L
Butanol	L	Butyl Acetate	L	Butyl Alcohol (100%)	L
Butylene	N	Butylene Glycol	L	Butylene, Liquid	N

Butyl Phenol	N	Butyric Acid	L
--------------	---	--------------	---

C

Calcium Carbonate	L	Calcium Chloride	L	Calcium Hydroxide	L
Calcium Hypochlorite	L	Calcium Nitrate (50%)	L	Calcium Sulfate	L
Camphor Oil	N	Carbon Disulfide	N	Carbonic Acid (Aq.CO2)	L
Carbon Monoxide	L	Carbon Tetrachloride	N	Castor Oil Conc.	L
Caustic [Aqueous]	L	Caustic Potash Sol. (50%)	L	Caustic Soda Sol, (10%),	L
Chloral Hydrate	L	Chloroethanol	L	Chloric Acid (10%)	L
Chloroacetic Acid	L	Chlorobenzene	L	Chloroform	N
Chloromethane	N	Chlorosulfonic Acid 100%	N	Chrome Alum Sat'd	L
Chromic Acid (50%)	S	Cider	L	Citric Acid (All Conc.)	L
Clorox Bleach	L	Coconut Oil Alcohols	L	Cola Concentrates	L
Compressed Air	L	Copper Salts	L	Copper Cyanide	L
Conditioning Oil	L	Copper Sulfate	L	Camphor Oil	N
Copper Nitrate (50%)	L	Cresol (90%)	L	Cresylic Acid	L
Cottonseed Oil	L	Cuprous Chloride Sat'd	L	Cyclohexane	L
Crotonic Aldehyde	L	Cyclohexanone	S		

D

Detergents, General	L	Developer, Photographic	L	Dextrin Sat'd	L
Dextrose Sat'd	L	Dibutyl Ether	N	Dibutylphthalate	S
Dibutyl Sebacate	S	Dichloroacetic Acid	S	Dichloroacetic Acid, Methyl Ester	S
Dichlorobenzene, Liquid	N	Dichloroethylene	N	Diesel Fuel	S
Diesel Oil	S	Diethyl Carbonate	L	Disodium Phosphate	L
Diazo Salts	L	Diethylene Glycol	L	Dithanolamine	S
Diglycolic Acid (30%)	L	Di-Isobutyl Ketone	S	Dimethylamine	S
Dimethyl Formamide	S	Dinonyl Phthalate	N	Diocetyl Phthalate	N
Dioxane	L	Diphenyl Oxide	N		

E

Electrolyte	L	Emulsions, Photographic	L	Ethanol	L
Ether	N	Ethyl Acetate (100%)	S	Ethyl Alcohol	L
Ethyl Butyrate	S	Ethyl Chloride	N	Ethyl Ether	N
Ethylene Chloride	N	Ethylene Chlorohydrin	L	Ethylene Diamine	L
Ethylene Dichloride	N	Ethylene Glycol	L	Ethylene Oxide	N

F

Fatty Acids	L	Fatty Alcohol Sulfonate	L	Ferric Salts	L
Ferric Sulfate	L	Ferrous Salts	L	Ferrous Sulfate	L
Fertilizer Salts	L	Fish Solubles	L	Fluoboric Acid	L
Fluosilicic Acid (All Conc.)	L	Formaldehyde (40%)	L	Formamide	L
Formic Acid (All Conc.)	L	Fruit Pulp	L	Fuel Oil	L
Furfural (100%)	L	Furfuryl Alcohol	N		

G

Gallic Acid Sat'd	L	Gasoline	L	Gasohol	L
Gelatine	L	Gin	L	Gluconic Acid (All Conc.)	L
Glucose	L	Glycerine	L	Glycol	L
Glycol Ethers	L	Glycolic Acid (All Conc.)	L	Grape Sugar Sat'd Aq.	L

H

Heptane	L	Hexane	L	Hexanol Tert	L
---------	---	--------	---	--------------	---

Hydrazine Hydrate	L	Hydrosulfite (10%)	L	Hydroxylamine Sulfate	L
Hydrozine (35%)	L	Hydrazine Hydrochloride	L	Hydroiodic Acid (All Conc.)	L
Hydrobromic Acid (50%)	L	Hydrocyanic Acid Sat'd	L	Hydrochloric Acid (All Conc.)	L
Hydrofluoric Acid (All Conc.)	L	Hydrofluorisilicic Acid (All Conc.),	L	Hydrogen Bromide (10%)	L
Hydrogen Peroxide (90%)	L	Hydrogen Phosphide 100%	L	Hydroquinone	L
Hydrogen Sulfide	L	Hypochlorous Acid	L		

I

Inks	L	Iodine (Alc. Sol.) Conc.	L	Iron Salts	L
Iso-Octane	S	Isopropyl Acetate	L	Isopropyl Alcohol	L
Isopropyl Ether	N				

J

Jetfuel	S				
---------	---	--	--	--	--

K

Kerosene	S				
----------	---	--	--	--	--

L

Lactic Acid (All Conc.)	L	Lanolin	L	Latex	L
Lead Salts	L	Lead Acetate Sat'd	L	Lime	L
Linseed Oil	L	Lithium Salts	L	Lube Oil	L

M

Magnesium Salts	L	Magnesium Carbonate	L	Magnesium Hydroxide	L
Magnesium Nitrate	L	Magnesium Oxide	L	Magnesium Sulfate	L
Maleic Acid	L	Malic Acid (1%)	L	Mercuric Salts	L
Mercurous Salts	L	Mercury	L	Methanol	L
Methyl Acetate	L	Methyl Alcohol (100%)	L	Methyl Amine (32%)	L
Methyl Bromide	N	Methyl Chloride	N	Methylene Chloride	N
Methyl Ethyl Ketone	S	Methyl Isobutyl Ketone	S	Methyl Isopropyl Ketone	S
Methyl Sulfate	L	Methyl Sulfuric Acid (All Conc.)	L	Milk	L
Mineral Oils	L	Molasses	L	Monochloroacetic Acid Ethyl Ester	L
Monochloroacetic Acid Methyl Ester	L	Morphalin	L	Mowilith D	L

N

Naptha	S	Napthalene	S	Nickel Salts	L
Nicotine, Dilute	L	Nicotinic Acid	L	Nitric Acid <50%	L
Nitrobenzene	S	Nitrotoluene	S		

O

Octyl Cresol	L	Oils and Fats	L	Oleic Acid (All Conc.)	L
Oleum Conc	N	Olive Oil	L	Orange Extract	L
Oxalic Acid (All Conc.)	L				

P

Palmitic Acid	N	Palm Oil	S	Paraffin Emulsions	L
Paraffin Oil	L	Perchloric Acid (50%)	L	Perchloroethylene	N
Petroleum	L	Petroleum Ether	S	Phenol (10%)	S
Phenylhydrazine	N	Phosphoric Acid All Conc	L	Phosphorous Chlorides	S
Phosphorous Yellow	L	Phosphorous Pentoxide	L	Photographic Solutions	L

(100%) Phthalic Acid (All Conc.)	L	Phthalic Anhydride	L	Pickling Baths, Sulfuric Acid, Hydrochloric Acid	L
Picric Acid (1%)	L	Plating Solutions	L	Potash	L
Potassium/Aluminum Sulfates (50%)	L	Potassium Bichromate	L	Potassium Borate (10%)	L
Potassium Bromide	L	Potassium Chlorate	L	Potassium Chloride	L
Potassium Chromate	L	Potassium Cyanide	L	Potassium Dichromate 40%	L
Potassium Ferri/ Ferro Cyanide Sat'd	L	Potassium Fluoride	L	Potassium Hydroxide	L
Potassium Iodide	L	Potassium Nitrate Sat'd	L	Potassium Perborate Sat'd	L
Potassium Perchlorate	L	Potassium Permanganate	L	Potassium Persulfate Sat'd	L
Potassium Phosphates	L	Potassium Sulfate,	L	Propanol	L
Propargyl Alcohol (7	L	Propionic Acid (50")	L	Propyl Alcohol	L
Propylene Dichloride (100.")	L	Propylene Glycol	L	Propylene Oxide	L
Pyridine	S				

R

Rayon Coagulation Salts,	L	Rust Inhibitors	L		
--------------------------	---	-----------------	---	--	--

S

Sea Water,	L	Selenic Acid	L	Sewage	L
Shortening	L	Silicic Acid	L	Silicone Oil	L
Silver Salts	L	Silver Nitrate	L	Soda Solution (All Conc.)	L
Soda Ash	L	Sodium Salts	L	Sodium Acetate Sat'd	L
Sodium Acrylates	L	Sodium Benzoate	L	Sodium Bicarbonate,	L
Sodium Bisulfate (10%)	L	Sodium Bisulfite	L	Sodium Bromate	L
Sodium Bromide	L	Sodium Bromide Dilute Sol.	L	Sodium Carbonate	L
Sodium Chlorate	L	Sodium Chloride	L	Sodium Chlorite	L
Sodium Chromate	L	Sodium Disulfite	L	Sodium Dithionite (10%)	L
Sodium Ferricyanide	L	Sodium Ferrocyanide Sat'd	L	Sodium Fluoride Sat'd	L
Sodium Hydroxide Conc.	L	Sodium Hypochlorite	L	Sodium Iodide	L
Sodium Nitrate	L	Sodium Oxalate	L	Sodium Persulfate	L
Sodium Phosphate	L	Sodium Silicate	L	Sodium Sulfide	L
Sodium Sulfide	L	Sodium Sulfite	L	Sodium Sulfonates	L
Sodium Thiosulfate	L	Spindle Oil	L	Stannic Salts	L
Stannous Salts	L	Starch Solution Sat'd	L	Stearic Acid (All Conc.)	L
Succinic Acid	L	Sugar Solutions, Glucose, Lactose, Sucrose, Etc.	L	Sulfur	L
Sulfuric Acid (98%)	S	Sulfuric Acid, Fuming	N	Sulfurous Acid	L
Sulfuryl Chloride	N				

T

Tallow	L	Tannic Acid	L	Tanning Extracts	L
Tartaric Acid Sat'd	L	Tetrachloroethane	L	Tetrachloroethylene	N
Tetraethyl Lead	L	Tetrahydrofuran	N	Tetrahydronaphthalene	N
Thionyl Chloride	N	Tin Salts	L	Titanium Salts	S
Toluene	S	Toluene Sulfonic Acid (All Conc.)	S	Transformer Oil	L
Tributylphosphate	L	Trichloroacetic Acid	S	Trichloroethane	N
Trichloroethylene,	N	Tricresyl Phosphate	L	Triethanolamine	L
Trioctyl Phosphate	N	Trisodium Phosphate Sat'd	L	Trichloroethylene	N
Turpentine Oil	N				

U

Urea	L	Urine	L		
------	---	-------	---	--	--

V

Vegetable Oil	L	Vinegar	L	Vanilla Extract	L
---------------	---	---------	---	-----------------	---

W

Wax Alcohol	N	Wetting Agents	L	Whisky	L
White Acid (75%)	L	Wine	L		

X

Xylene	N				
--------	---	--	--	--	--

Y

Yeast	L				
-------	---	--	--	--	--

Z

Zinc Salts	L	Zinc Sulfate	L		
------------	---	--------------	---	--	--

¿Por qué utiliza polietileno (PE) para fabricar sus productos?

El polietileno es un material sintético termoplástico que pertenece al grupo de las poliolefinas. Por su estructura atómica única el PE es un material con una alta resistencia química contra las sustancias químicas más corrientes. Es un material sintético relativamente sencillo de tratar permitiendo formas complicadas. Gracias a las buenas propiedades mecánicas, a la fuerza de tracción, a la fluencia, a la elasticidad en caso de rotura, el PE es una materia prima muy popular para gran cantidad de aplicaciones.

¿Cuál es la carga que el PE puede ocasionar sobre el medio ambiente?

El polietileno es un derivado de petróleo y se produce en refinerías y empresas químicas por medio del proceso llamado "craqueo" del petróleo hasta etileno. El etileno es un gas que a su vez se combina para obtener el PE. El polietileno es enteramente reutilizable cuando ya no sirve suficientemente en su aplicación actual. A este efecto se pasa al procedimiento de purificación, de trituración, de nueva extrusión para transformarlo en "pellets" que podrán ser empleados para fabricar nuevos productos.

¿Por qué los productos de Novodinamica son de color amarillo?

El color natural del PE es el blanco opaco. En esta forma el PE tiene la resistencia química más elevada. Hemos optado por el amarillo porque sólo se necesita un poco de colorante para colorar nuestros productos manteniendo al mismo tiempo su resistencia química máxima. Además el amarillo es un color que salta a la vista y por lo tanto nuestros productos tienen también una función de señal.

¿Es posible conectar los productos a tierra?

Por el hecho de que el PE es un aislador, no tiene mucho sentido proporcionar los productos de una conexión a tierra. En efecto, una carga que no se formará en la conexión a tierra, no se desviará tampoco.

¿Es inflamable el polietileno?

Como el PE pertenece al grupo de las poliolefinas, es inflamable. Cuando quema, forma gotas que se evaporan y se encienden. El punto de inflamación se sitúa a 340°C a 350°C aproximadamente. El calor que se desprende con la combustión se eleva a unos 48 kJ/kg. Cuando hay combustión a una temperatura bastante elevada y con un suministro suficiente de oxígeno, el PE se disocia en principio en H₂O y CO₂.

¿Es el polietileno resistente a la intemperie?

Como la mayoría de los materiales naturales y sintéticos, a largo plazo el PE será degradado por la acción combinada de los rayos UV y del oxígeno presente en la atmósfera. Se llama este fenómeno la foto-oxidación. Los productores del PE onocen esta problemática y proveen sus semiproductos hechos de PE de antioxidantes y de estabilizadores UV. Todos los productos de Novodinamica son controlados a una temperatura mínima de -18°C y a una temperatura máxima de 40°C.

¿Puedo utilizar para productos muy ligeramente inflamables?

En principio es la decisión del utilizador. Aunque, como el PE puede formar carga estática, y no es conductor, es preciso actuar con mucho cuidado. La energía en una chispa a causa de una descarga estática ya puede ser suficiente para hacer inflamarse una mezcla inflamable de gas - aire.

Certificado de Control de Fabricación

NOMBRE Y DIRECCIÓN DEL FABRICANTE

NOVODINÁMICA, S.L.U.

Vía Murcia, 86.

50.420 Cadrete. ZARAGOZA

POR EL PRESENTE SE CERTIFICA QUE EL CUBETO DE RETENCIÓN ABAJO EXPUESTOS CUMPLE CON LAS DISPOSICIONES CONSTRUCTIVAS EXIGIDAS EN EL REGLAMENTO DE ALMACENAMIENTO DE PRODUCTOS LÍQUIDOS Y SUS INSTRUCCIONES TÉCNICAS COMPLEMENTARIAS (R.D. 656/2007).

1. Modelo: Cubeta colectora Ref.3063
2. Constructor: NOVODINAMICA, S.L.U.
3. Tipo: CUBA POLIETILENO. 1.400 x 1.400 x 950 1.016 L.
4. Año de construcción: 2021

NOMBRE: PABLO GARCÍA

CARGO: DIRECTOR GERENTE

FIRMA

