

Technical Specification Sheet

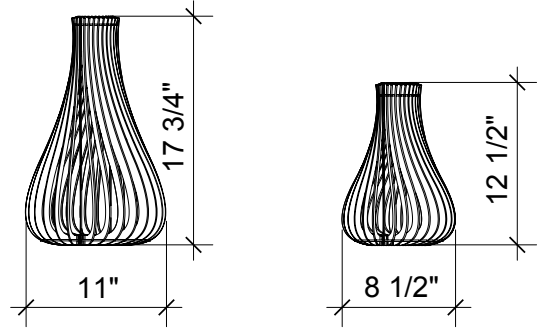

Meringue Pendant

A series of pendant light in 2 distinctive sizes: organic curved shape.

Process	Meringue shades are formed with the use of vertical slats. Assembly is required. Once assembled the individual pieces form a strong form that is unified. Kit set light-shades are on average 1/30th of the volume of the assembled light. This aims to help minimize the effects of shipping and to reduce the design's environmental footprint.
Year of Design	2022
Product Code	MERMINPND - Mini MERSTPND - Standard
Type	Pendant Light
Color	Light Walnut
Certification	UL Certified FSC EPA TSCA TITLE IV CARB Phase 2
Cleaning Instructions	Clean with a soft dry cloth only. Do not use polishing agents, water or abrasive materials when cleaning. Always switch off the electricity supply before cleaning



Bulb Spec	
Wattage	Max 60W, 110-130V
Socket Size	E26 E27



Wire Length	47.2 inches adjustable cable
Wire Color	Black
Canopy Color	Black



Packaging (in)	18Lx12Wx4H
----------------	------------



Weight (lb)	
MERMINPND	2.3lb
MERSTPND	3.5lb