

Relied upon since 1969

Mini Cable Seal

This high security seal is petroleum and sunlight resistant and features an ultra smooth insertion locking body.

The Mini Cable Seal can be used for multiple applications. This includes sealing ISO containers, trucks, tanker trucks, rail cars, valves and more.

Features:

- Non-preformed cable frays when cut
- Laser printed (increased security)
- Petroleum & sunlight resistance
- Smooth insertion “pull tight” locking
- Removable by standard cable cutters
- Plastic free locking body

Material:

Aluminium alloy locking

Breaking Strength

Greater than 200kg

Unit Dimensions:

Cable length: 300mm

Cable diameter: 1.5mm

Locking body: 24 x 14 x 5mm

Carton Dimensions (1000 Units):

330 x 210 x 210mm (Weight 12.5kg)

Code:

SS20002 (Blue - Stock Numbered)



Relied upon since 1969

Mini Cable Seal

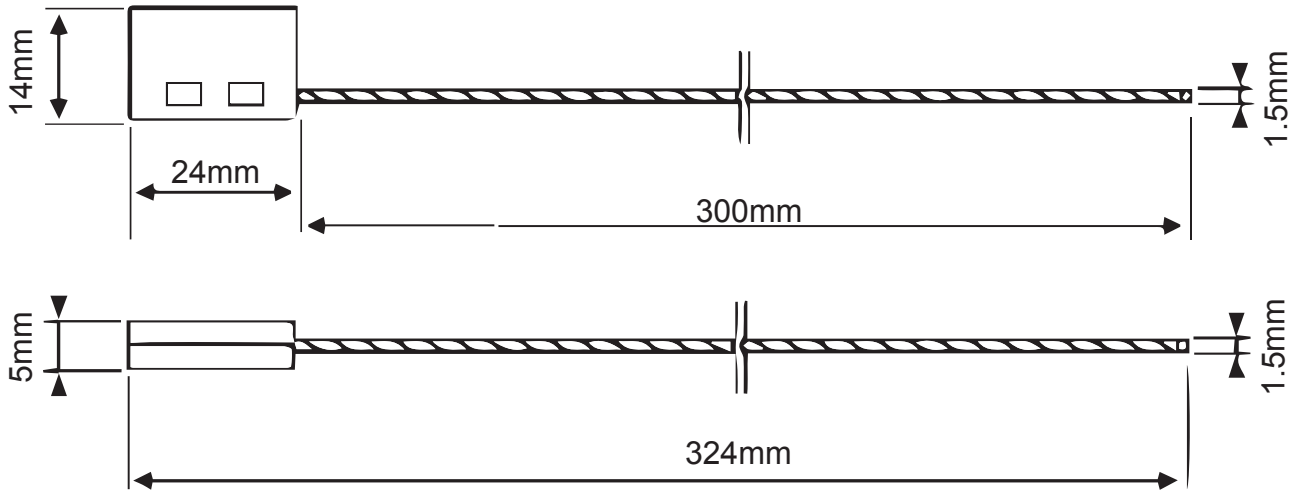

Packaging

Standard Bag Packaging: 100 pieces | Standard Carton Packaging: 1000 pieces

Minimum Order

100 Units

Custom Options :

Logo and sequential numbering (laser) | Barcode (laser) | Selection of colours (blue, green, red and black) | Choice of cable length

