

# Cash 40

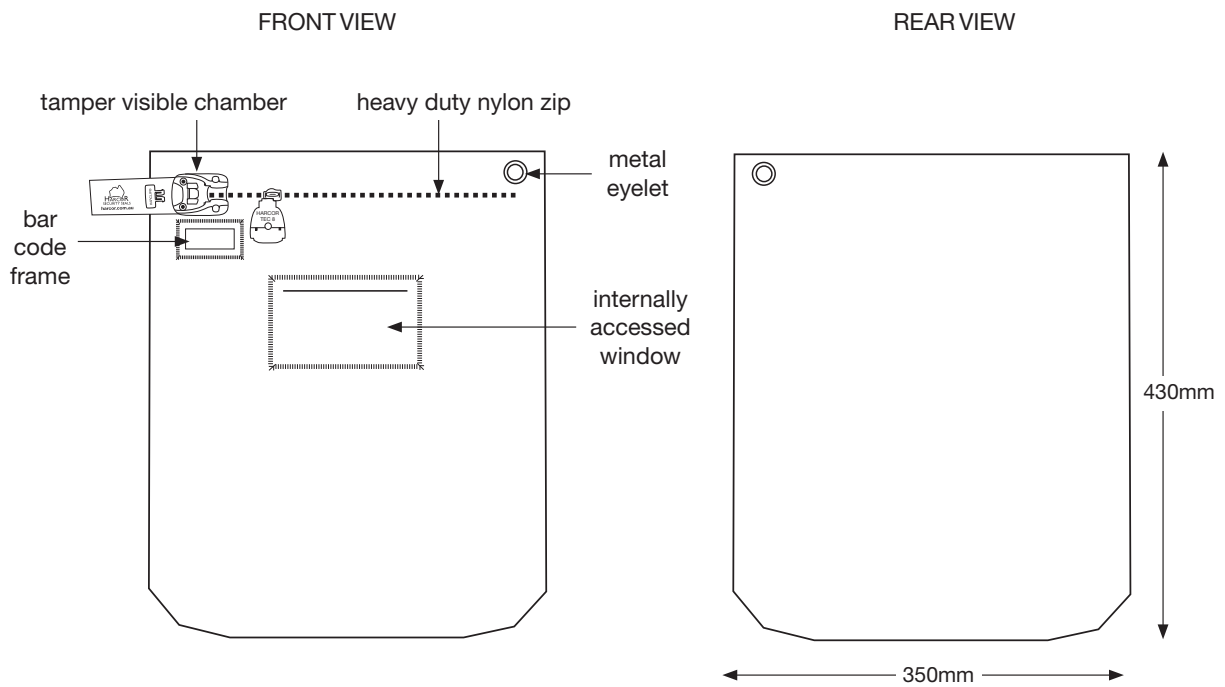

## CASH 40 HC4008A..

- For cash movement
- Internally accessed window
- External dimensions 350 x 430mm

COLOURS: 02 ● 08 ● 12 ●

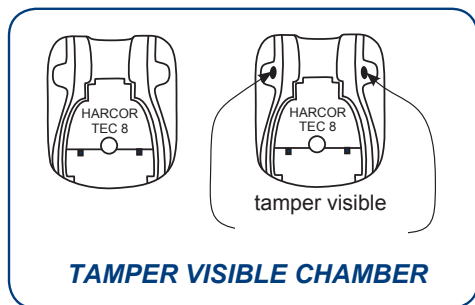
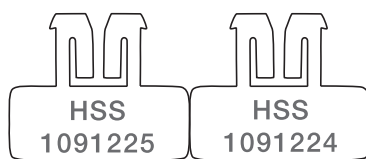
**HARCLIP™ SEAL (NUMBERED) HA056..**

- Seals can be customised with logo and/or barcoded (min run 10,000)
- Australian designed
- Plain - orange only (HA05010)
- Minimum: 1,000

COLOURS: 02 ● 08 ● 12 ● 13 ● 14 ○