

Relied upon since 1969

Springlok

The Springlok Security Seal offers effortless sealing. This self-locking, tamper indicating plastic seal has a unique hinge design.

Used by multiple industries such as: catering, hotel, hospital and many others.

Key features

- Easy to close (one-handed action).
- Plastic body blushes if tampered with.
- Quick and easy removal by twisting at break-point on spear shaft.
- Secure donut hole locking chamber.
- Hinge spring opens to show evidence of tampering.

Material

Polypropylene

Minimum Order Quantity

1000 unit box

Carton (5000 units)

Size: 710 x 380 x 250mm

Weight: 10kg

5000 units per carton

1000 units per box

Strength Characteristics

Pull apart strength: 3.6kg

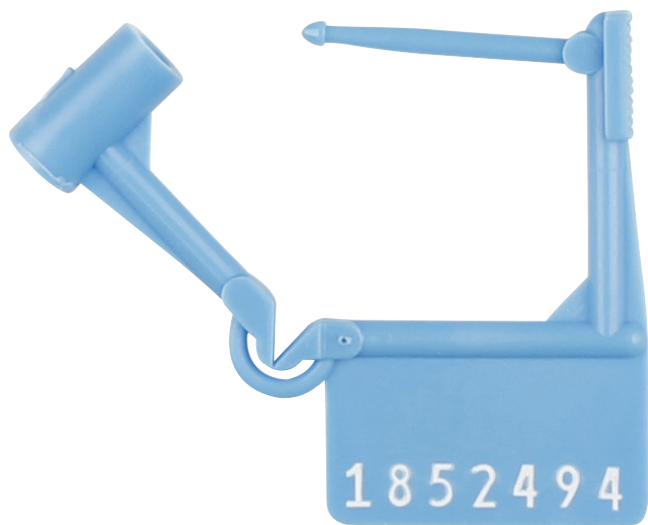

| Code | Description |
|---------|-------------------------------------|
| BR03003 | SPRINGLOK Blue - Stock Numbered |
| BR03009 | SPRINGLOK Green - Stock Numbered |
| BR03010 | SPRINGLOK Orange - Stock Numbered |
| BR03012 | SPRINGLOK Red - Stock Numbered |
| BR03014 | SPRINGLOK Yellow - Stock Numbered |

Custom Options | One colour logo

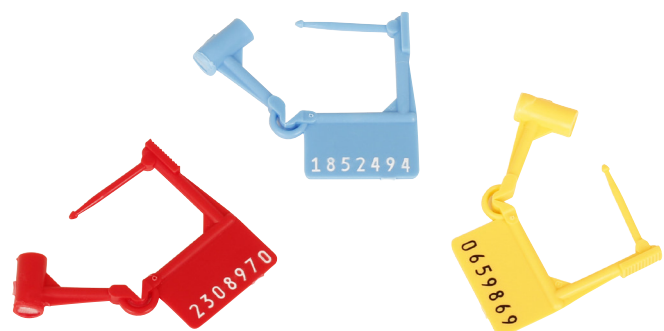

Springlok

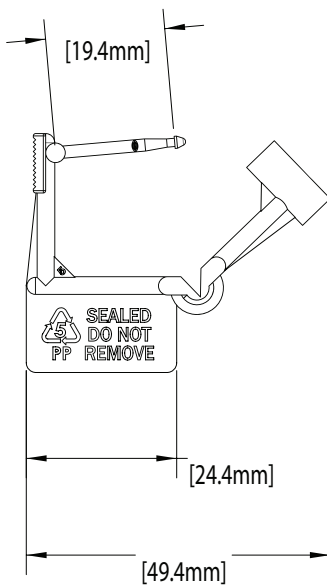

STANDARD SHAFT

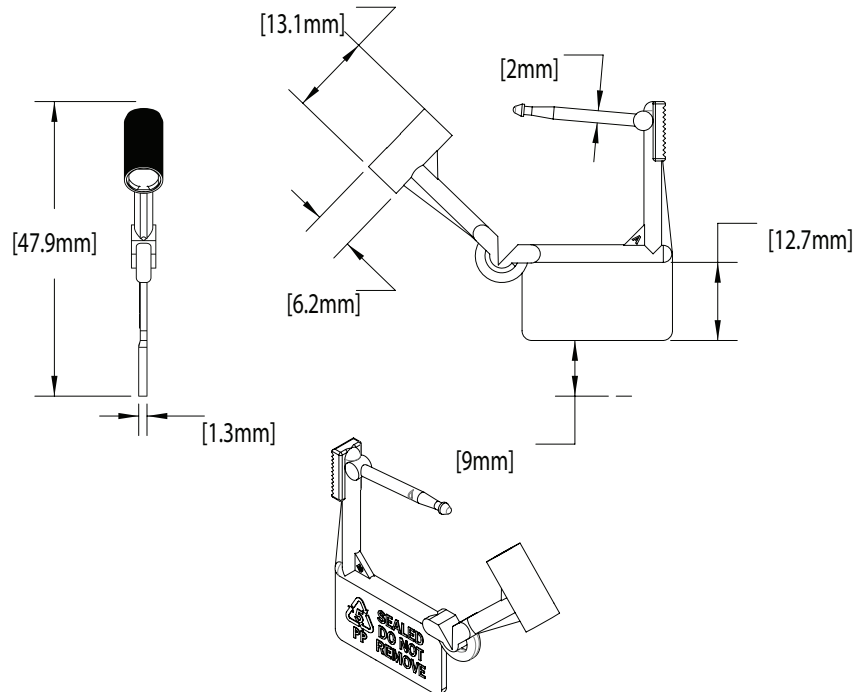

Usage Instructions:

Harcor recommend having a procedure in place to record the unique serial numbers prior to use and removal of a security seal. To seal simply place your thumb and forefinger at opposite ends of the security seal and then squeeze. This action will insert the spear of the security seal into the chamber and lock. To remove the seal twist at break-point on spear shaft.

