

Silicon Tuning Diode

This device is designed for FM tuning, general frequency control and tuning, or any top-of-the-line application requiring back-to-back diode configurations for minimum signal distortion and detuning.

- High Figure of Merit — $Q = 140$ (Typ) @ $V_R = 3.0$ Vdc, $f = 100$ MHz
- Guaranteed Capacitance Range
37–42 pF @ $V_R = 3.0$ Vdc (MV104)
- Dual Diodes – Save Space and Reduce Cost
- Monolithic Chip Provides Near Perfect Matching – Guaranteed $\pm 1.0\%$ (Max) Over Specified Tuning Range

MV104

**DUAL
VOLTAGE VARIABLE
CAPACITANCE DIODE**

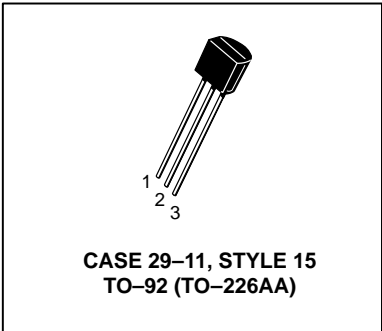

MAXIMUM RATINGS (EACH DIODE)

Rating	Symbol	Value	Unit
Reverse Voltage	V_R	32	Vdc
Forward Current	I_F	200	mAdc
Total Power Dissipation @ $T_A = 25^\circ\text{C}$ Derate above 25°C	P_D	280 2.8	mW mW/°C
Junction Temperature	T_J	+125	°C
Storage Temperature Range	T_{stg}	-55 to +150	°C

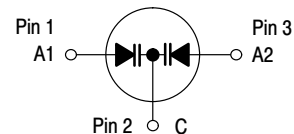

ELECTRICAL CHARACTERISTICS ($T_A = 25^\circ\text{C}$ unless otherwise noted) (EACH DIODE)

Characteristic	Symbol	Min	Typ	Max	Unit
Reverse Breakdown Voltage ($I_R = 10 \mu\text{Adc}$)	$V_{(BR)R}$	32	—	—	Vdc
Reverse Voltage Leakage Current $T_A = 25^\circ\text{C}$ ($V_R = 30$ Vdc) $T_A = 60^\circ\text{C}$	I_R	—	—	50 500	nAdc
Diode Capacitance Temperature Coefficient ($V_R = 4.0$ Vdc, $f = 1.0$ MHz)	TC_C	—	280	—	ppm/°C

Device	C_T , Diode Capacitance $V_R = 3.0$ Vdc, $f = 1.0$ MHz pF		Q , Figure of Merit $V_R = 3.0$ Vdc $f = 100$ MHz		C_R , Capacitance Ratio C_3/C_{30} $f = 1.0$ MHz	
	Min	Max	Min	Typ	Min	Max
MV104	37	42	100	140	2.5	2.8

MV104

TYPICAL CHARACTERISTICS (Each Diode)

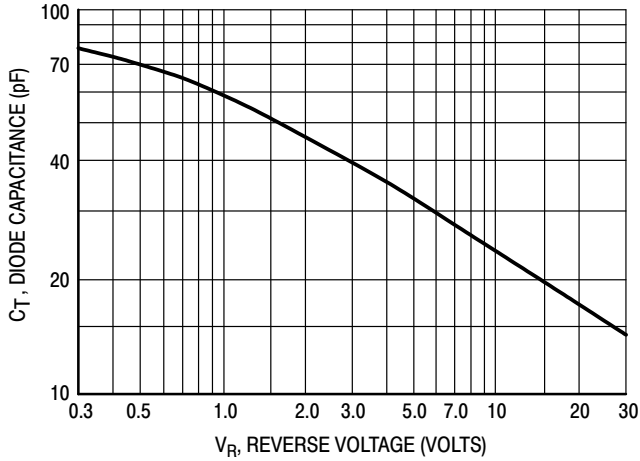

Figure 1. Diode Capacitance (Each Diode)

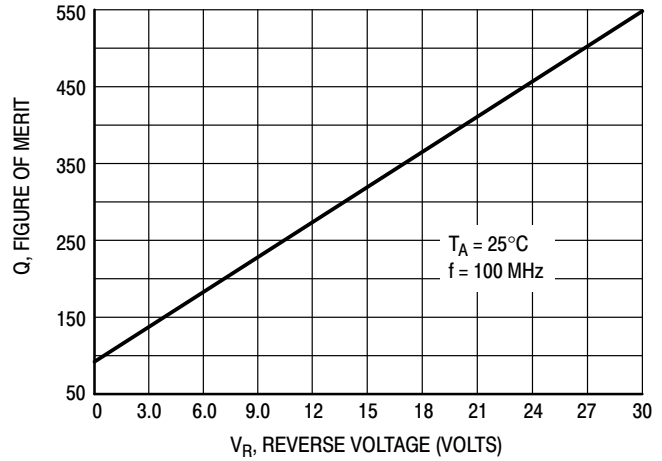

Figure 2. Figure of Merit versus Voltage

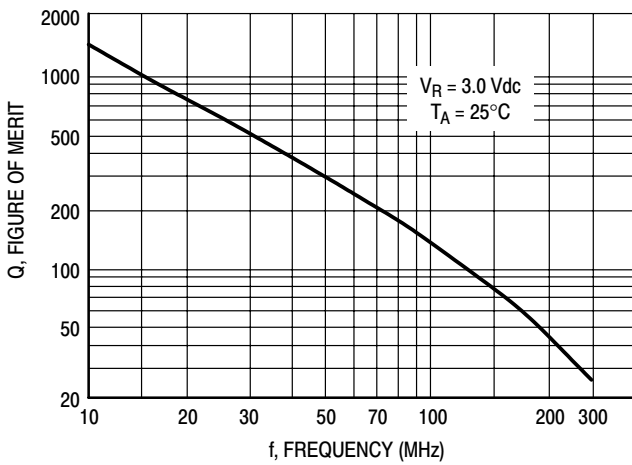

Figure 3. Figure of Merit versus Frequency

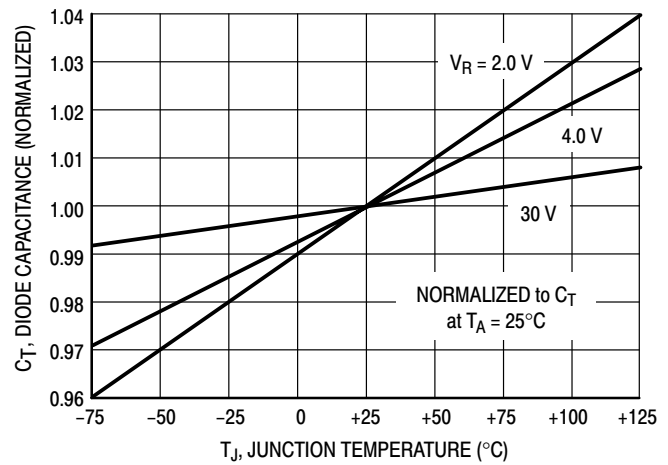

Figure 4. Diode Capacitance versus Temperature

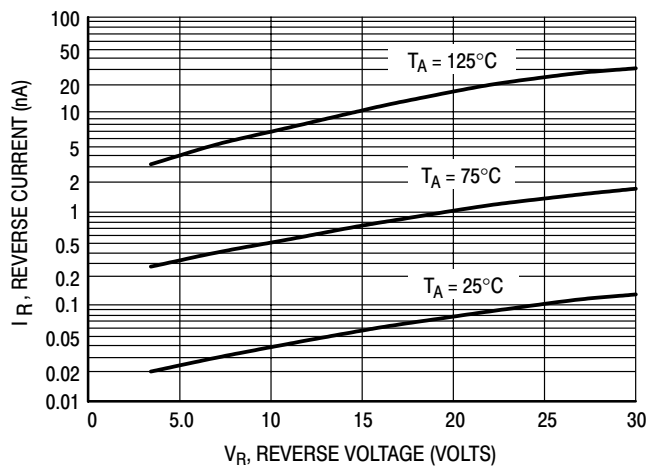
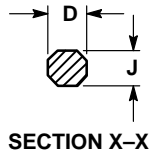
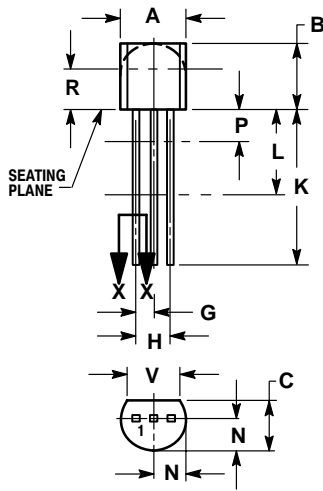

Figure 5. Reverse Current versus Reverse Voltage

MV104

PACKAGE DIMENSIONS

TO-92 (TO-226AA) CASE 29-11 ISSUE AL



YLE 15:
PIN 1. ANODE 1
2. CATHODE
3. ANODE 2

NOTES:

1. DIMENSIONING AND TOLERANCING PER ANSI Y14.5M, 1982.
2. CONTROLLING DIMENSION: INCH.
3. CONTOUR OF PACKAGE BEYOND DIMENSION R IS UNCONTROLLED.
4. LEAD DIMENSION IS UNCONTROLLED IN P AND BEYOND DIMENSION K MINIMUM.

DIM	INCHES		MILLIMETERS	
	MIN	MAX	MIN	MAX
A	0.175	0.205	4.45	5.20
B	0.170	0.210	4.32	5.33
C	0.125	0.165	3.18	4.19
D	0.016	0.021	0.407	0.533
G	0.045	0.055	1.15	1.39
H	0.095	0.105	2.42	2.66
J	0.015	0.020	0.39	0.50
K	0.500	---	12.70	---
L	0.250	---	6.35	---
N	0.080	0.105	2.04	2.66
P	---	0.100	---	2.54
R	0.115	---	2.93	---
V	0.135	---	3.43	---