

## 2N6394-2N6399

## SILICON CONTROLLED RECTIFIER

Available Non-RoHS (standard) or RoHS compliant (add PBF suffix).  
Available as "HR" (high reliability) screened per MIL-PRF-19500, JANTX level. Add "HR" suffix to base part number.

### MAXIMUM RATINGS

Rating	Symbol	Value	Unit
<b>Peak repetitive forward and reverse blocking voltage<sup>(1)</sup></b> (T <sub>J</sub> = -40 to +125°C, sine wave, 50 to 60 Hz, gate open)	V <sub>RRM</sub> , V <sub>DRM</sub>	50	Volts
2N6394		100	
2N6395		400	
2N6397		800	
2N6399			
<b>On state RMS current</b> (180° conduction angles, T <sub>C</sub> = 90°C)	I <sub>T(RMS)</sub>	12	Amps
<b>Peak non-repetitive surge current</b> (1/2 cycle, 60Hz, sine wave, T <sub>J</sub> = 90°C)	I <sub>TSM</sub>	100	Amps
<b>Circuit fusing considerations</b> (t = 8.3ms)	I <sup>2</sup> t	40	A <sup>2</sup> s
<b>Forward peak gate power</b> (pulse width ≤ 1.0μs, T <sub>C</sub> = 90°C)	P <sub>GM</sub>	20	Watts
<b>Forward average gate power</b> (t = 8.3ms, T <sub>C</sub> = 90°C)	P <sub>G(AV)</sub>	0.5	Watts
<b>Forward peak gate current</b> (pulse width ≤ 1.0μs, T <sub>C</sub> = 90°C)	I <sub>GM</sub>	2	Amps
<b>Operating junction temperature range</b>	T <sub>J</sub>	-40 to +125	°C
<b>Storage temperature range</b>	T <sub>stg</sub>	-40 to +150	°C

Note 1: V<sub>DRM</sub> and V<sub>RRM</sub> for all types can be applied on a continuous basis without incurring damage. Ratings apply for zero or negative gate voltage; however, positive gate voltage shall not be applied concurrent with negative potential on the anode. Blocking voltages shall not be tested with a constant current source such that the voltage ratings of the devices are exceeded.

### THERMAL CHARACTERISTICS

Characteristic	Symbol	Maximum	Unit
<b>Thermal resistance, junction to case</b>	R <sub>θJC</sub>	2.0	°C/W
<b>Maximum lead temperature for soldering purposes 1/8" from case for 10 seconds</b>	T <sub>L</sub>	260	°C

### ELECTRICAL CHARACTERISTICS (T<sub>C</sub> 25°C unless otherwise noted)

Characteristic	Symbol	Min.	Typ.	Max.	Unit
<b>OFF CHARACTERISTICS</b>					
<b>Peak forward or reverse blocking current</b> (V <sub>AK</sub> = Rated V <sub>DRM</sub> or V <sub>RRM</sub> , gate open) T <sub>J</sub> = 25°C T <sub>J</sub> = 100°C	I <sub>DRM</sub> or I <sub>RRM</sub>	-	-	10	μA
		-	-	2.0	mA
<b>ON CHARACTERISTICS</b>					
<b>Peak forward on-state voltage<sup>(2)</sup></b> (I <sub>TM</sub> = 24A peak)	V <sub>TM</sub>	-	1.7	2.2	Volts
<b>Gate trigger current (continuous dc)</b> (V <sub>D</sub> = 12 Vdc, R <sub>L</sub> = 100 Ω)	I <sub>GT</sub>	-	5.0	30	mA
<b>Gate trigger voltage (continuous dc)</b> (V <sub>D</sub> = 12 Vdc, R <sub>L</sub> = 100 Ω)	V <sub>GT</sub>	-	0.7	1.5	Volts
<b>Gate non-trigger voltage</b> (V <sub>D</sub> = 12 Vdc, R <sub>L</sub> = 100 Ω, T <sub>J</sub> = 125°C)	V <sub>GD</sub>	0.2	-	-	Volts
<b>Holding current</b> (V <sub>D</sub> = 12Vdc, initiating current = 200mA, gate open)	I <sub>H</sub>	-	6.0	50	mA
<b>Turn on time</b> (I <sub>TM</sub> = 12A, I <sub>GT</sub> = 40mAdc, V <sub>D</sub> = rated V <sub>DRM</sub> )	t <sub>gt</sub>	-	1.0	2.0	μs

# 2N6394-2N6399

# SILICON CONTROLLED RECTIFIER

Characteristic	Symbol	Min.	Typ.	Max.	Unit
Turn-off time ( $V_D = \text{rated } V_{DRM}$ ) ( $I_{TM} = 12A, I_R = 12A$ ) ( $I_{TM} = 12A, I_R = 12A, T_J = 125^\circ C$ )	$t_q$	-	15	-	$\mu s$
		-	35	-	
<b>DYNAMIC CHARACTERISTICS</b>					
Critical rate of rise of off-state voltage exponential ( $V_D = \text{rated } V_{DRM}, T_J = 125^\circ C$ )	dv/dt	-	50	-	V/ $\mu s$

Note 2: Pulse test: Pulse width  $\leq 300\mu s$ , duty cycle  $\leq 2\%$ .

## MECHANICAL CHARACTERISTICS

Case	TO-220AB
Marking	Body painted, alpha-numeric
Pin out	See below

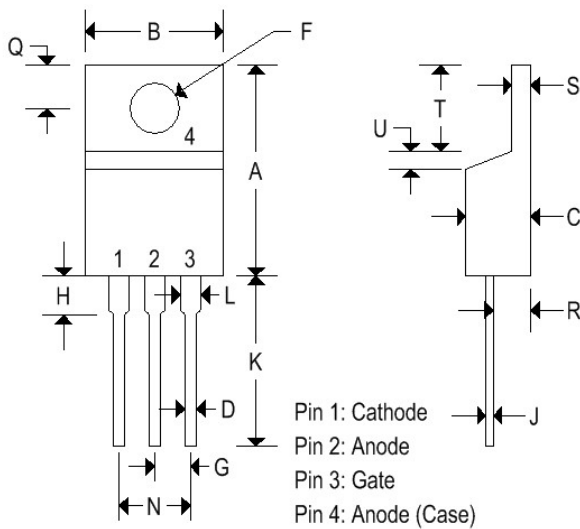

	TO-220AB			
	Inches		Millimeters	
	Min	Max	Min	Max
A	0.575	0.620	14.600	15.750
B	0.380	0.405	9.650	10.290
C	0.160	0.190	4.060	4.820
D	0.025	0.035	0.640	0.890
F	0.142	0.147	3.610	3.730
G	0.095	0.105	2.410	2.670
H	0.110	0.155	2.790	3.930
J	0.014	0.022	0.360	0.560
K	0.500	0.562	12.700	14.270
L	0.045	0.055	1.140	1.390
N	0.190	0.210	4.830	5.330
Q	0.100	0.120	2.540	3.040
R	0.080	0.110	2.040	2.790
S	0.045	0.055	1.140	1.390
T	0.235	0.255	5.970	6.480
U	-	0.050	-	1.270
V	0.045	-	1.140	-
Z	-	0.080	-	2.030

Voltage Current Characteristic of SCR

Symbol	Parameter
$V_{DRM}$	Peak Repetitive Off State Forward Voltage
$I_{DRM}$	Peak Forward Blocking Current
$V_{RRM}$	Peak Repetitive Off State Reverse Voltage
$I_{RRM}$	Peak Reverse Blocking Current
$V_{TM}$	Peak On State Voltage
$I_H$	Holding Current

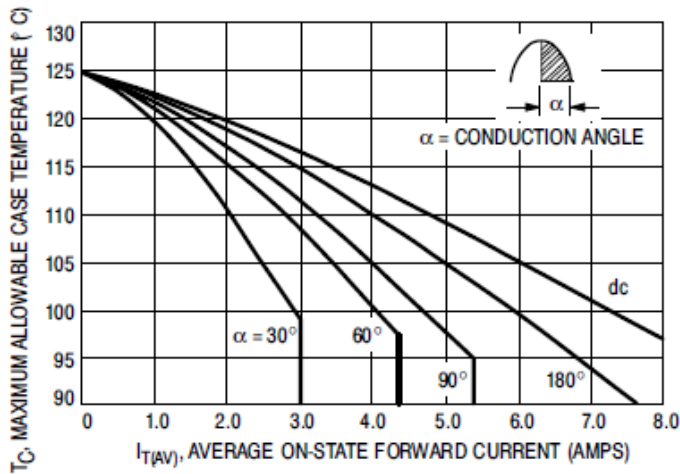
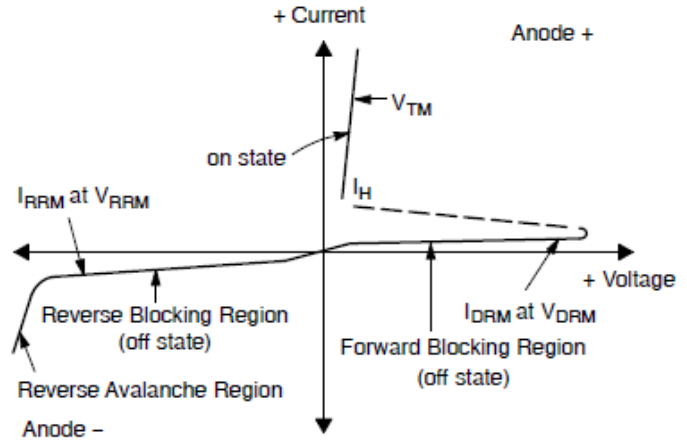

Figure 1. Current Derating

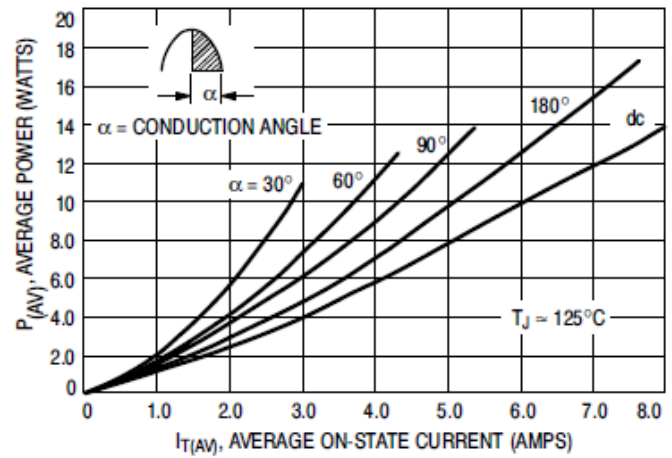

Figure 2. Maximum On-State Power Dissipation

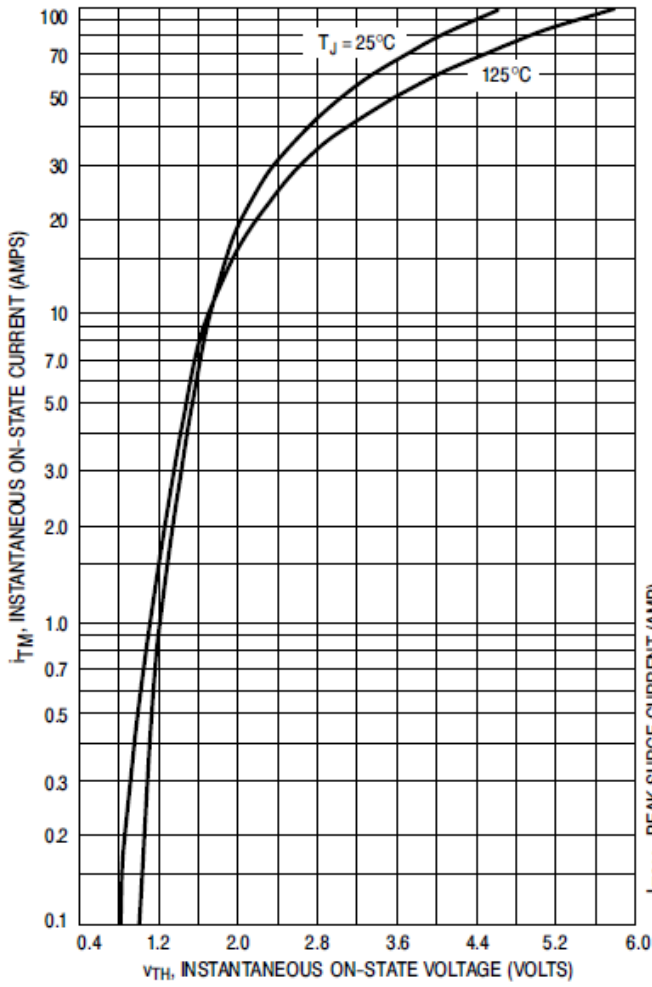

Figure 3. On-State Characteristics

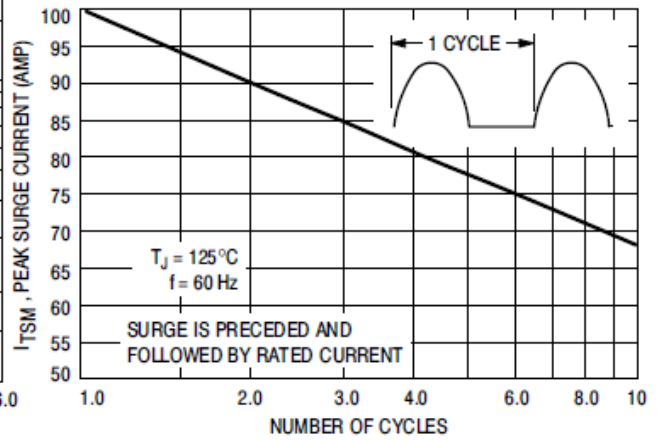

Figure 4. Maximum Non-Repetitive Surge Current

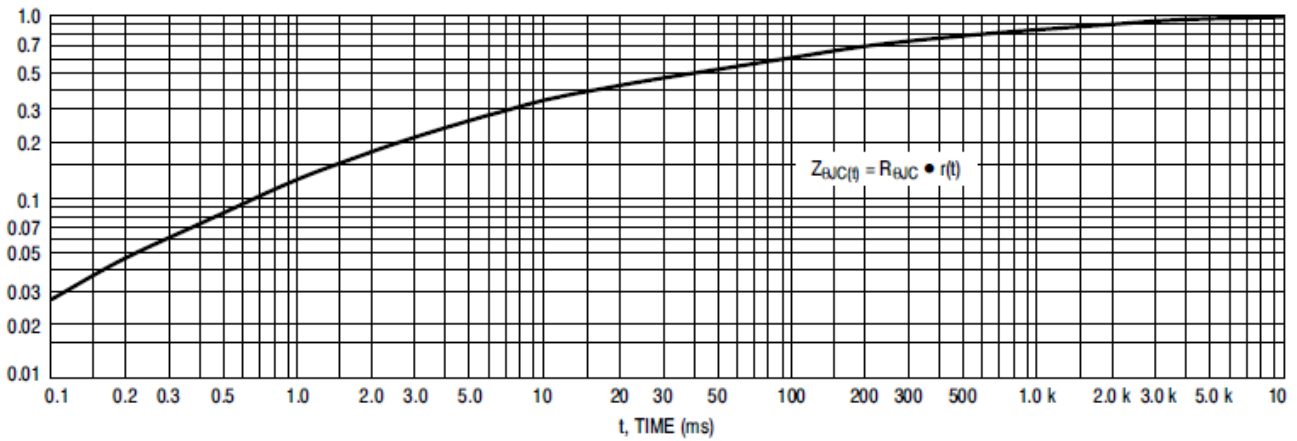

Figure 5. Thermal Response

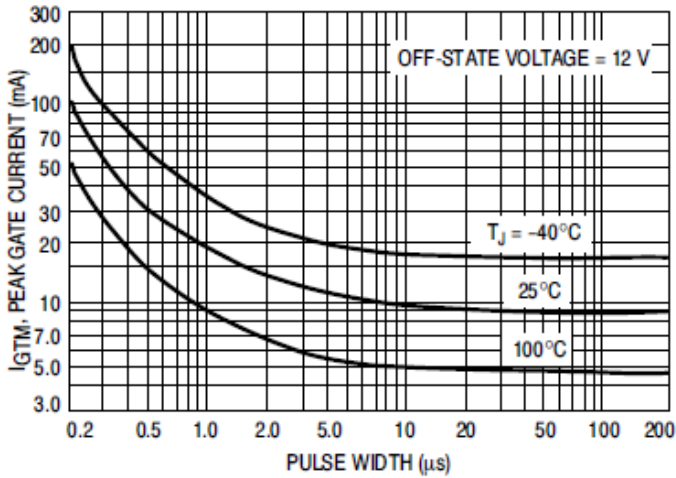

Figure 6. Typical Gate Trigger Current versus Pulse Width

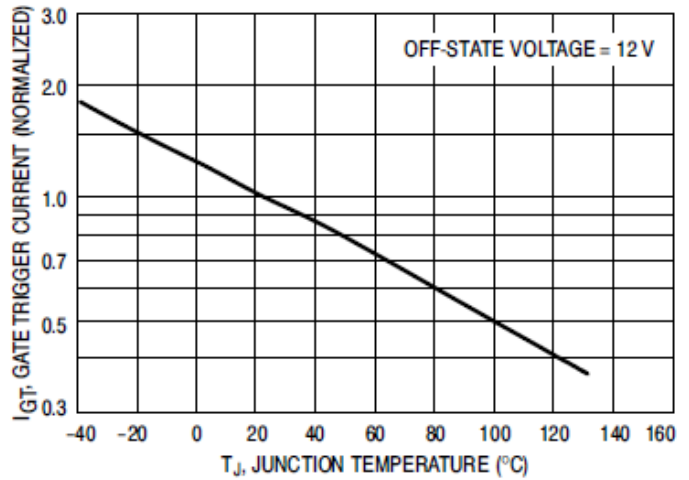

Figure 7. Typical Gate Trigger Current versus Temperature

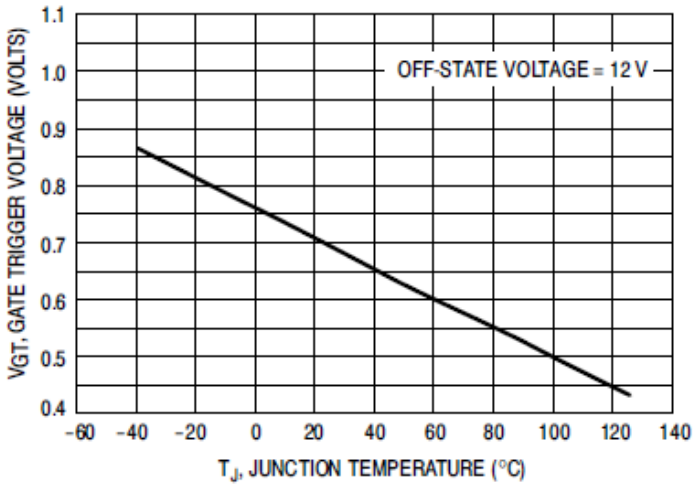

Figure 8. Typical Gate Trigger Voltage versus Temperature

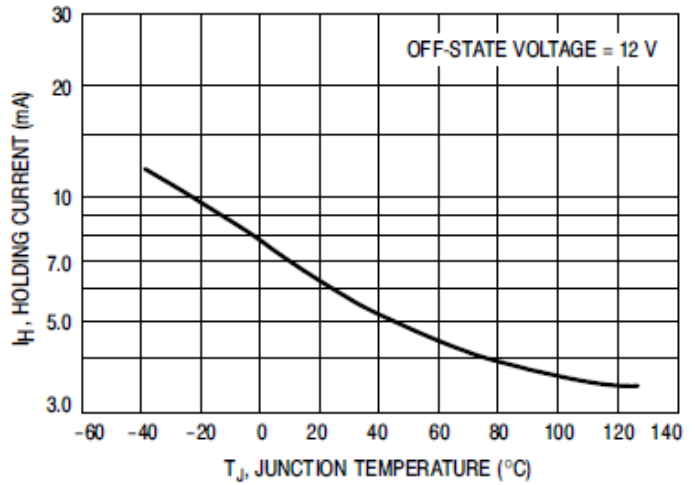

Figure 9. Typical Holding Current versus Temperature