

# Jumbo 4" 7 Segment Display

Part No. 08LSD40165-20

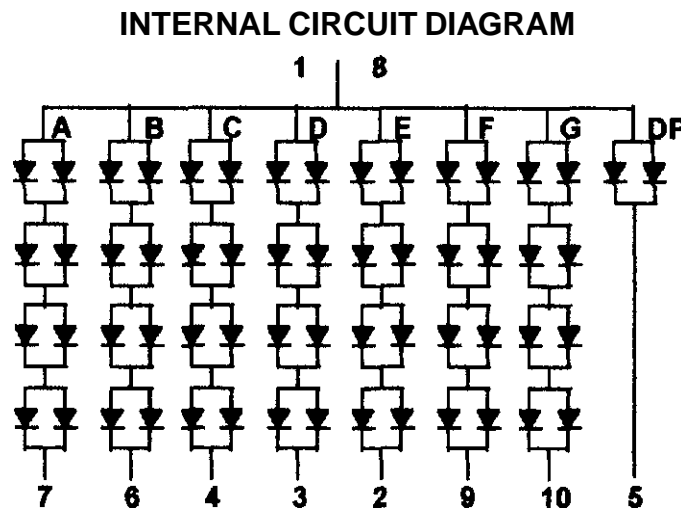
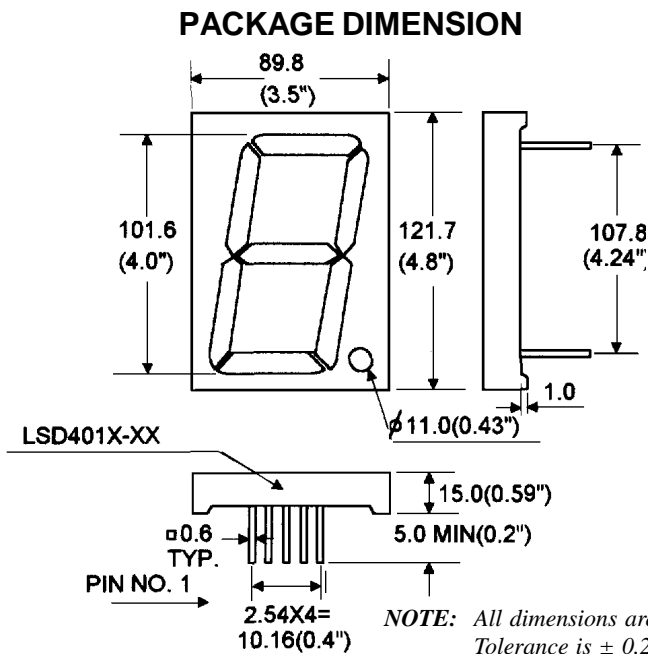

## CONNECTION TO ELECTRICAL SCHEMATIC

### Electrical Connection

Pin No.	08LSD40165-20
1	Common Anode
2	Cathode E
3	Cathode D
4	Cathode C
5	Cathode DP
6	Cathode B
7	Cathode A
8	Common Anode
9	Cathode F
10	Cathode G

## ABSOLUTE MAXIMUM RATING (Ta=25°C)

Parameter	Red	Unit
Forward Current Per Chip	20	mA
Peak Current Per Chip (Duty 1/10, 0.1MS Pulse Width)	60	mA
Power Dissipation Per Chip	45	mW
Derating Linear From 25°C Per Chip	0.25	mA / °C
Reverse Current Per Any Chip	10	μA
Operating Temperature	-25° TO +85°C	
Storage Temperature	-25° TO +85°C	
Solder Temperature 1/16 Inch Below Seating Plane For 3 Seconds at 260°C		

## Jumbo 4" 7 Segment Display

(Part No. 08LSD40165-20) CON'T

### PART SELECTION AND APPLICATION INFORMATION (RATINGS AT 25°C AMBIENT)

Part No.	Chip		Common Cathode or Anode	$\lambda P$ (nm)	$\Delta \lambda$ (nm)	Electrical				
	Material	Emitted				Vf(v)			Iv(mcd)	
						Min.	Typ.	Max.	Min.	Typ.
08LSD40165-20	GaAIAs	Red	Common Anode	660	20	1.5	1.7	2.4	18	30

### TEST CONDITION FOR EACH PARAMETER

Parameter	Symbol	Unit	Test Condition
Forward Voltage Per Chip	Vf	volt	If=20mA
Luminous Intensity per Chip	Iv	mcd	If=10mA
Peak Emission Wavelength	$\lambda P$	nm	If=20mA
Spectral Line Half-Width	$\Delta \lambda$	nm	If=20ma
Reverse Current Any Chip	Ir	$\mu A$	Vr=5V