

Jumbo 2.3" 7 Segment Display

Part No. 08LSD23265

PACKAGE DIMENSION

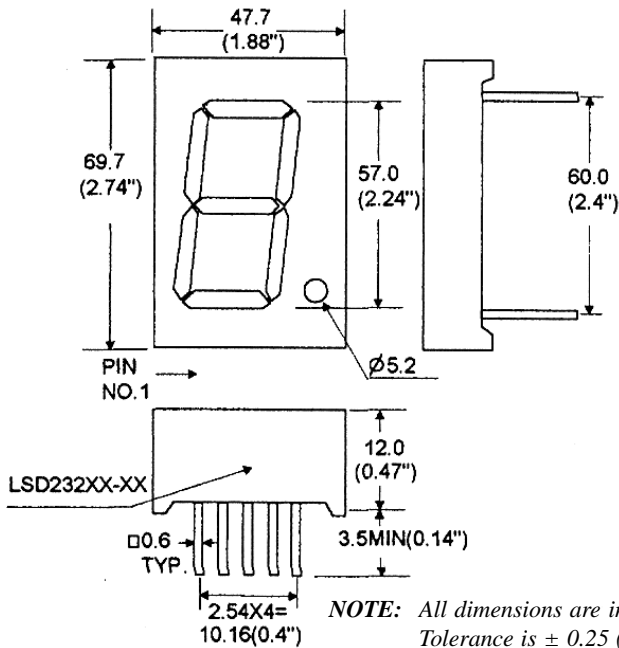

INTERNAL CIRCUIT DIAGRAM

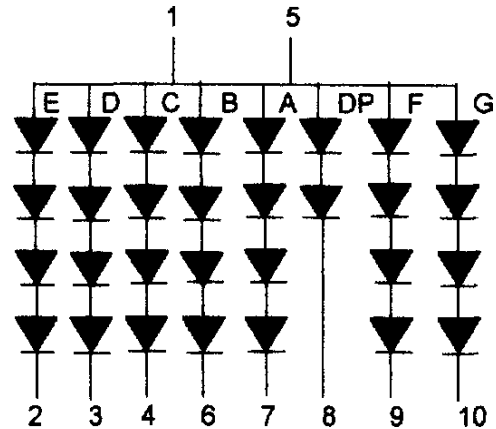

CONNECTION TO ELECTRICAL SCHEMATIC

Electrical Connection

Pin No.	08LSD23265
1	Common Anode
2	Cathode E
3	Cathode D
4	Cathode C
5	Common Anode
6	Cathode B
7	Cathode A
8	Cathode DP
9	Cathode F
10	Cathode G

ABSOLUTE MAXIMUM RATING (Ta=25°C)

Parameter	Red	Unit
Forward Current Per Chip	20	mA
Peak Current Per Chip (Duty 1/10, 0.1MS Pulse Width)	60	mA
Power Dissipation Per Chip	45	mW
Derating Linear From 25°C Per Chip	0.25	mA / °C
Reverse Current Per Any Chip	10	μA
Operating Temperature	-25° TO +85°C	
Storage Temperature	-25° TO +85°C	
Solder Temperature 1/16 Inch Below Seating Plane For 3 Seconds at 260°C		

Jumbo 2.3" 7 Segment Display

(Part No. 08LSD23265) CONT

PART SELECTION AND APPLICATION INFORMATION (RATINGS AT 25°C AMBIENT)

Part No.	Chip		Common Cathode or Anode	λP (nm)	$\Delta\lambda$ (nm)	Electrical				
	Material	Emitted				Vf(v)			Iv(mcd)	
						Min.	Typ.	Max.	Min.	Typ.
08LSD23265	GaAIAs	Red	Common Anode	660	20	1.5	1.7	2.4	12	21

TEST CONDITION FOR EACH PARAMETER

Parameter	Symbol	Unit	Test Condition
Forward Voltage Per Chip	Vf	volt	If=20mA
Luminous Intensity per Chip	Iv	mcd	If=10mA
Peak Emission Wavelength	λP	nm	If=20mA
Spectral Line Half-Width	$\Delta\lambda$	nm	If=20ma
Reverse Current Any Chip	Ir	μA	Vr=5V