

PmodRS485™ Reference Manual

Revised April 12, 2016

This manual applies to the PmodRS485 rev. B

Overview

The Digiilent PmodRS485 provides signal and power isolation for high speed communication lines utilizing the RS-485 communication protocol.

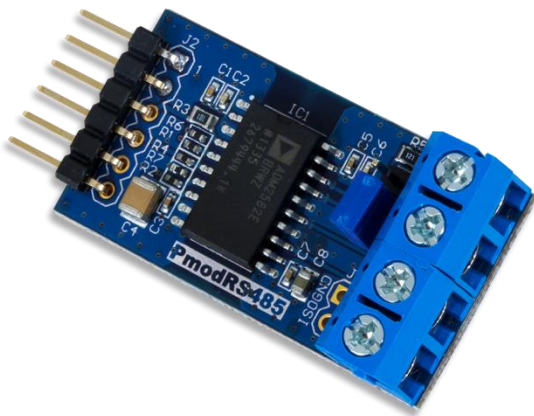

The PmodRS485.

Features include:

- High-speed RS-485 communication module
- Isolated RS-485/RS-422 interfaces for use in noisy environments
- 16Mbps maximum data rate
- Connect up to 256 nodes on one bus
- Differential half or full-duplex communication
- Thermal shutdown and $\pm 15\text{kV}$ ESD protection
- 6-pin Pmod port with UART interface
- Library and example code available in [resource center](#)

1 Functional Description

The PmodRS485 utilizes [Analog Devices ADM2582E](#) to facilitate RS-485 and RS-422 serial communication protocols between devices in environments with high electrical noise. The ADM2582E provides both signal and power isolation allowing for accurate data transfer across long distances. Data transmission rates of 16 Mbit/s can be achieved.

2 Interfacing with the Pmod

The PmodRS485 communicates with the host board via the UART protocol. In order to transmit data, the Driver Enable line must be pulled to a logic level high voltage state; similarly, in order to receive data, the Receive Enable line must be driven to a logic level low voltage state.

Truth tables indicating the status of the various pins of the PmodRS485 are provided below:

Inputs		Output
A-B Voltage Difference	~RE	RxD
$\geq -0.03V$	Low or Not Connected	High
$\leq -0.2V$	Low or Not Connected	Low
$-0.2V < A-B < -0.03V$	Low or Not Connected	Don't Care
Inputs Open	Low or Not Connected	High
Don't Care	High	High Impedance

Table 1. Receiving.

Inputs		Output	
DE	TxD	Y	Z
High	High	High	Low
High	Low	Low	High
Low	Don't Care	High Impedance	High Impedance

Table 2. Transmitting.

Pin	Signal	Description
1	~RE	Receive Enable
2	TxD	Transmit Data
3	RxD	Receive Data
4	DE	Driver Enable
5	GND	Power Supply Ground
6	VCC	Positive Power Supply (3.3V/5V)

Table 3. Pinout description table: Pmod Header J2.

Signal	Description
A	Input A
B	Input B
Z	Output Z
Y	Output Z

Table 4. Screw terminals.

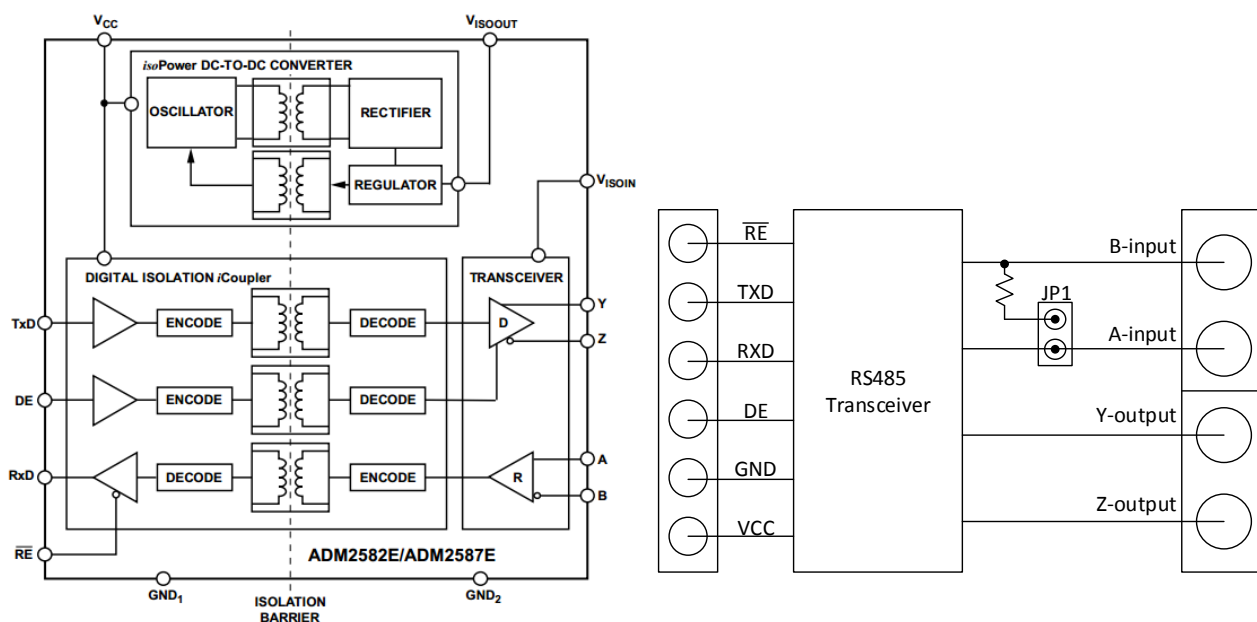

Figure 1. PmodRS485 functional block diagram.

Multiple PmodRS485 devices can be chained together up to 256 nodes in total. When two PmodRS485s are connected, JP1 should be loaded on both devices. When more than two PmodRS485s are connected, JP1 should only be loaded on the two devices at the terminating ends of the wire, and stubs off of the main line should be kept as short as possible.

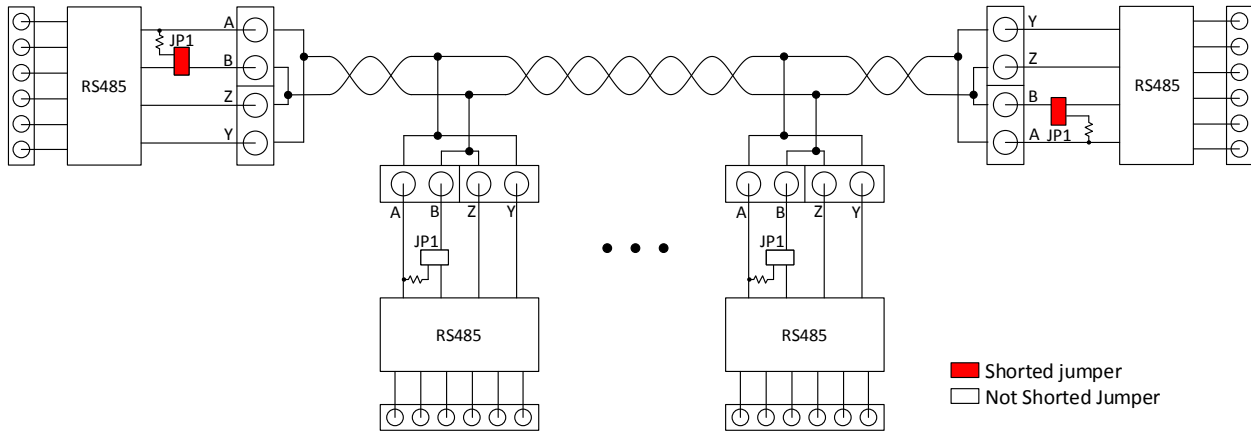

Figure 2. Half-duplex communication.

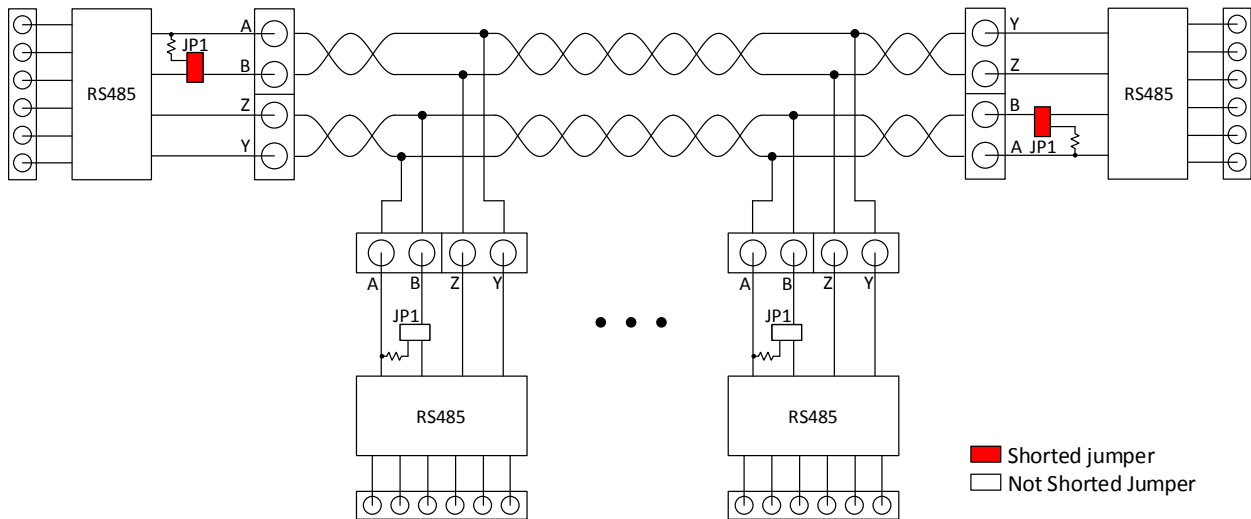
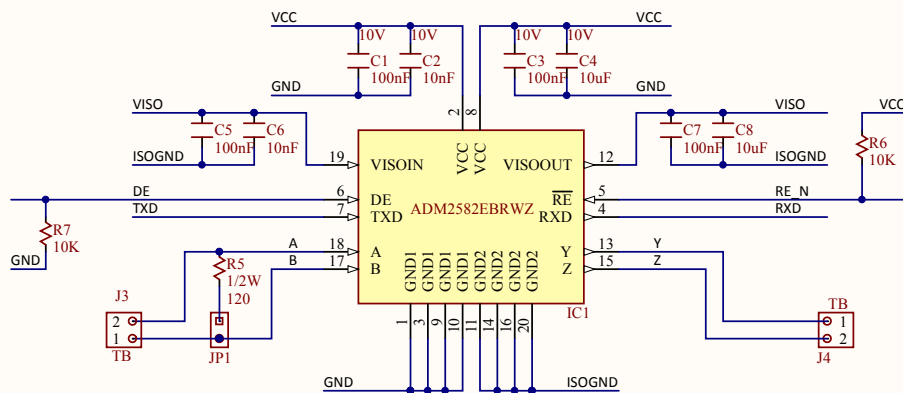
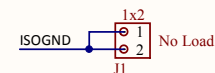
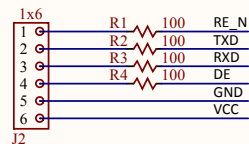



Figure 3. Full-duplex communication.

Any external power applied to the PmodRS485 must be within 3.0V and 5.5V; however, it is recommended that Pmod is operated at 3.3V.

3 Physical Dimensions

The pins on the pin header are spaced 100 mil apart. The PCB is 1.5 inches long on the sides parallel to the pins on the pin header and 0.8 inches long on the sides perpendicular to the pin header.



Title PmodRS485		Rev B.0 Copyright 2014
Circuit Primary Circuit		
Doc# 500-310		
Engineer MTA		
Author GMA		
Date 7/15/2014		
Sheet# 1 out of 1		