

PmodAMP3™ Reference Manual

Revised April 15, 2016

This manual applies to the PmodAMP3 rev. A

Overview

The Digilent PmodAMP3 features an [Analog Devices® SSM2518](#) 2 watt Class-D Audio Power Amplifier. The module enables the use of I²S audio protocol or TDM to produce stereo audio at various sampling frequencies. Users may configure the digital volume and dynamic range control via an I²C interface. Additionally, the PmodAMP3 may be used in a stand-alone mode that does not require the use of the I²C interface.

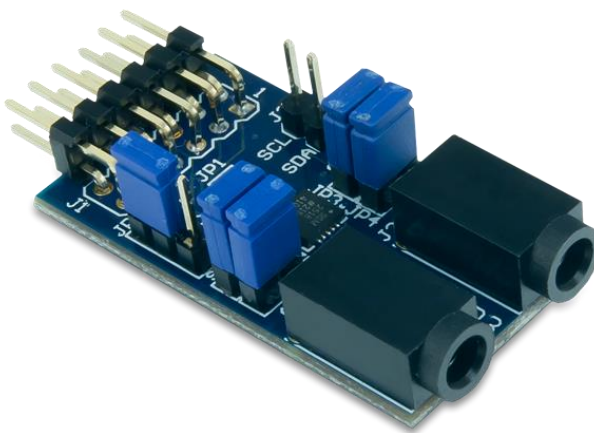

The PmodAMP3.

Features include:

- Audio amplifier with left and right channel separation
- Stereo output via two standard 1/8" (0.32 cm) mono speaker jacks
- Supports common I²S audio formats
- Digitally configurable volume control for each channel
- Dynamic range control
- Stand-alone mode for systems without I²C interface
- Small PCB size for flexible designs 1.5" × 0.8" (3.8 cm × 2.0 cm)
- 12-pin Pmod port with I²C interface

1 Functional Description

The PmodAMP3 utilizes Analog Devices SSM2518 to reproduce digitally fed audio signals in separate left and right headphone jacks. The separation of the jacks enables better audio signal isolation.

2 Interfacing with the Pmod

The PmodAMP3 communicates with the host board via the I²C protocol. Users may operate the PmodAMP3 in either an I²C programmable mode or a simple stand-alone mode. The stand-alone mode is the default setting and can be activated by removing the shorting block on jumper JP5. When the stand-alone mode is active, jumpers JP3, JP4, and JP6 allow a simple hardware configuration of the amplifier.

Within the stand-alone mode jumper JP3 configuration determines whether to use Standard or Left Justified I²S protocol. Jumper JP4 determines if the MCLK input is 256 or 384 times the audio sampling frequency F_s . The jumper JP6 configures the amplifier to output at either 0dB or +12dB gain.

If JP5 is loaded, I²C is enabled so that the on-board chip can be configured. Consequently, the shorting blocks on both JP3 and JP4 must be removed so that the SCL and SDA lines are pulled to a logic high voltage state. JP6 sets the I²C address of the Pmod; both addresses are valid, but a user may want to use one particular address if another I²C device on the bus is using the other address.

	JP5 Unloaded (default Stand-alone mode)		JP5 Loaded (I ² C Programmable Mode)	
	Loaded	Unloaded	Loaded	Unloaded
JP2	MCLK-provide own external MCLK	BCLK-route BCLK to MCLK input	Don't Care	Don't Care
JP3	I ² S (Standard)	Left Justified	Prohibited	Required
JP4	256x Fs	384x Fs	Prohibited	Required
JP6	12dB Gain	0dB Gain	ADDR: 0110100[r/w]	ADDR: 0110110[r/w]

Table 1. Connector descriptions.

Note: Both the 0dB and +12dB gain modes are very loud. You should take care to protect both yourself and your equipment when operating in stand-alone mode. Digilent recommends that you use the programmable mode and set the gain to -12dB or lower.

The I²C programmable mode is used to set alternate Master Clock (MCLK) and Bit Clock (BCLK) ratios as well as configure the Dynamic Range Control (DRC). More information about these options is available in our [user guide](#).

To transfer audio data in the I²S audio format, the MCLK, BCLK, the Left/Right Word Clock (LRCLK), and the data (SDATA) will need to be provided either internally or externally as appropriate. This module is able to receive audio data anywhere between 8 and 32-bits of resolution. An example timing diagram from Texas Instruments on how I²S data is to be sent to the module is provided below:

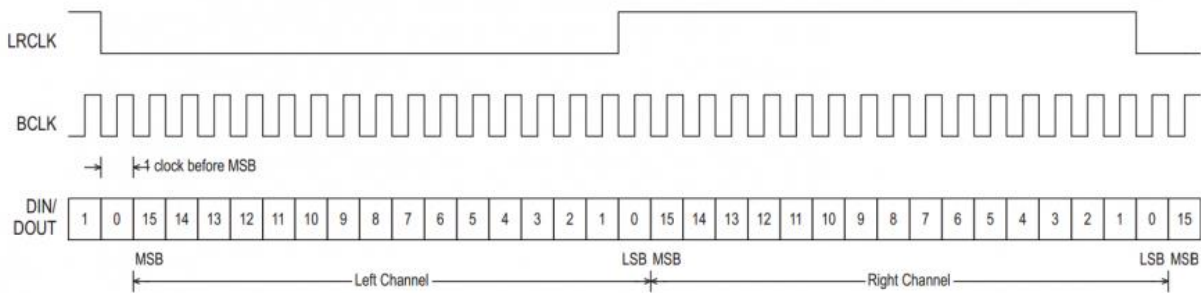

Figure 1. Example I²S timing diagram.

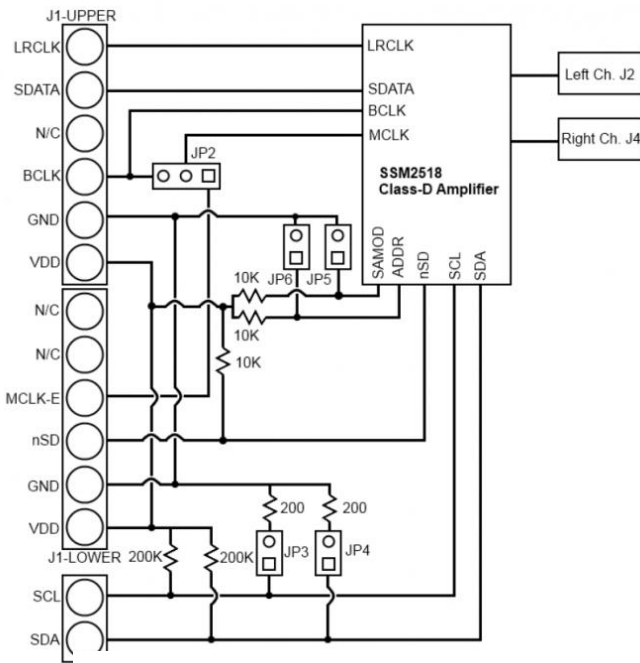

Figure 2. PmodAMP3 block diagram.

Header J1		
Pin	Signal	Description
1	LRCLK	Left/Right Word Clock
2	SDATA	Serial Data
3	NC	Not Connected
4	BCLK	Bit Clock
5	GND	Power Supply Ground
6	VCC	Positive Power Supply
7	NC	Not Connected
8	NC	Not Connected
9	MCLK-E	Master Clock-external
10	~SHUT	Shutdown
11	GND	Power Supply Ground
12	VCC	Positive Power Supply

Table 2. Header J1 pinout table.

Header J2		Header J3		Header J4	
Pin	Description	Pin	Description	Pin	Description
1	Left Audio Jack	1	Serial Clock	1	Right Audio Jack
		2	Serial Data		

Table 3. Header J2, J3, and J4 pinout table.

Any external power applied to the PmodAMP3 must be within 2.5V and 5.5V; however, it is recommended that the Pmod is operated at 3.3V.

3 Physical Dimensions

The pins on the pin header are spaced 100 mil apart. The PCB is 1.5 inches long on the sides parallel to the pins on the pin header and 0.8 inches long on the sides perpendicular to the pin header.

Note: If external voltage is desired remove R1 and load JP1.

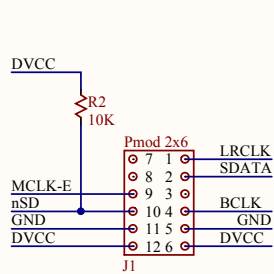

Note: For this Pmod, the voltage applied to DVCC must be kept between 2.7V and 5.5V to avoid damaging the parts used in this circuit.

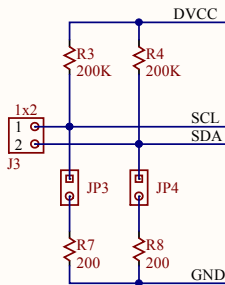

When not operating in stand-alone mode, remove JP3 and JP4.

	LOADED	UNLOADED
JP3	I2S	Left Justified
JP4	256 x Fs	384 x Fs
JP5	I2C	Stand-Alone
JP6	12dB Gain	0dB Gain

Fs = Audio Sampling Rate

Default

For more information on the parts used in this design, please refer to: www.analog.com/SSM2518 - Digital Input Stereo, 2W, Class-D Audio Power Amplifier

ROHS Chinese ROHS

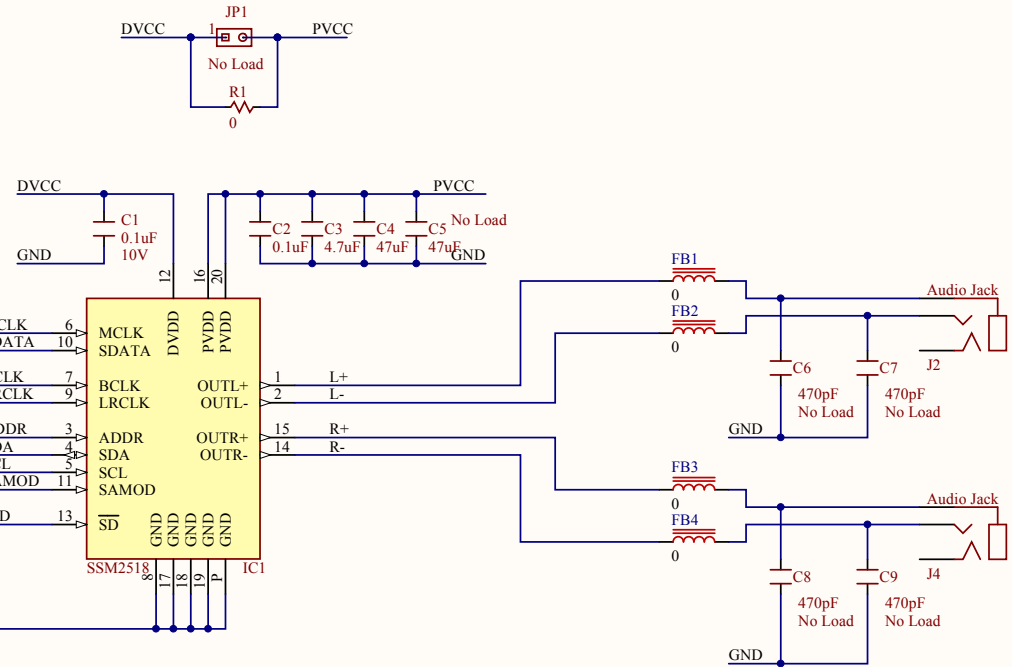

Title PmodAMP3		Rev A.0
Circuit Main Circuit	Copyright	
Doc# 500-270	DIGILENT®	
Engineer MA	BEYOND THEORY	
Author GA		
Date 9/18/2012		
Sheet# 1 out of 1		