

PmodGYRO™ Reference Manual

Revised April 12, 2016

This manual applies to the PmodGYRO rev. A

Overview

The PmodGYRO is a 3-axis gyroscope powered by the STMicroelectronics L3G4200D. By communicating with the chip through SPI or I²C, users may configure the module to report angular momentum at a resolution of up to 2000 dps at an output rate up to 800Hz.

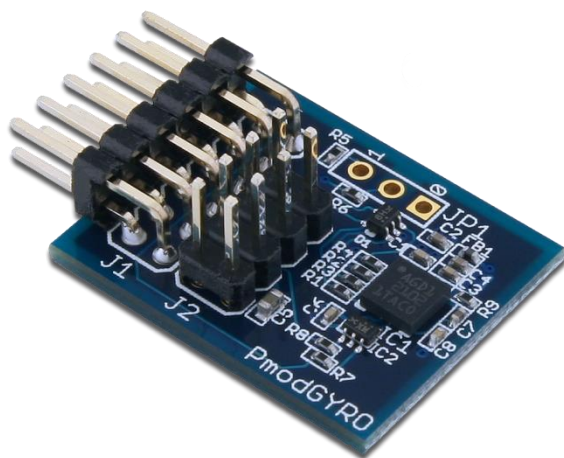

The PmodGYRO.

Features include:

- 3-axis MEMS digital gyroscope with high shock survivability
- Get angular momentum data with user selectable resolution (250/500/2000dps)
- Two customizable interrupt pins
- User configurable signal filtering
- Power-down and Sleep modes
- Small PCB size for flexible designs 1.0 in × 0.8 in (2.5 cm × 2.0 cm)
- 12-pin Pmod port with SPI interface and additional I²C interface
- Library and example code available in [resource center](#)

1 Functional Description

The PmodGYRO utilizes [ST L3G4200D gyroscope](#) to provide motion sensing data on each of the three Cartesian axes. Users may configure both the resolution and filtering options for the measured data.

2 Interfacing with the Pmod

The PmodGYRO communicates with the host board via the SPI or I²C protocols. By driving the Chip Select (CS) line to a logic low voltage state, SPI mode is enabled. The first byte sent over SPI informs the on-board chip if a read or write command is going to be issued, if the register address should be incremented after a particular command has been completed, and the 5 bit address of the register that is to be written to.

An example timing diagram for SPI read and writes from the L3G4200D datasheet is provided below:

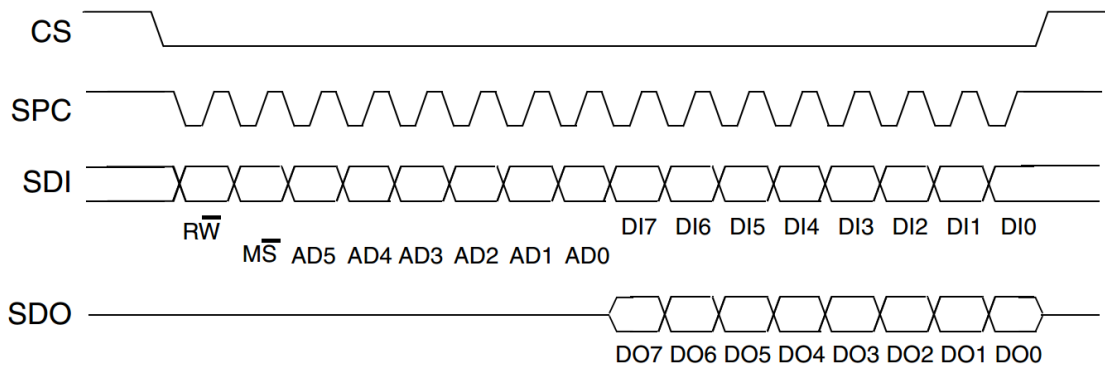

Figure 1. Timing diagram.

Correspondingly, if the CS line is left at a high voltage state by an internal pull-up resistor, the I²C mode of the PmodGYRO is enabled. The on-board chip has two possible slave address in the form of 110100x where x is the voltage state of the Master-In-Slave-Out (MISO) pin on the SPI header. After the slave address and the read or write bit has been transmitted and the message was acknowledged, a 7-bit register address can then be transmitted. The most significant bit (the first bit of the 8-bit of the transfer) indicates if multiple bytes of information are to be transferred.

An example transfer scheme for a master device reading multiple bytes of data from the PmodGYRO is provided below:

Master	Slave
Start	
Slave address and Write bit	
	ACK
Multi-byte bit and register address	
	ACK
Restart	
Slave address and read bit	
	ACK
	Data
ACK	
	Data
ACK	
	Data
NACK	
Stop	

Table 1. Example transfer scheme.

Data is recorded and stored within the registers of the L3G4200D in degrees per second (dps). Correspondingly, a measured value of 360 dps is equivalent to 60 rpm. Users can retrieve data from the PmodGYRO by following the provided code example.

2.1 Pinout Description Table

Header J1						Header J2		
Pin	Signal	Description	Pin	Signal	Description	Pin	Signal	Description
1	~CS	Chip Select	7	INT1	Interrupt 1	1, 5	SCL	Serial Clock
2	MOSI	Master-Out-Slave-In	8	INT2	Interrupt 2	2, 6	SDA	Serial Data
3	MISO	Master-In-Slave-Out	9	(NC)	Not Connected	3, 7	GND	Power Supply Ground
4	SCLK	Serial Clock	10	(NC)	Not Connected	4, 8	VCC	Positive Power Supply (3.3V)
5	GND	Power Supply Ground	11	GND	Power Supply Ground			
6	VCC	Positive Power Supply (3.3V)	12	VCC	Positive Power Supply (3.3V)			

Table 2. Pinout description table.

Any external power applied to the PmodGYRO must be within 2.4V and 3.6V; however, it is recommended that Pmod is operated at 3.3V.

3 Physical Dimensions

The pins on the pin header are spaced 100 mil apart. The PCB is 1 inch long on the sides parallel to the pins on the pin header and 0.8 inches long on the sides perpendicular to the pin header.

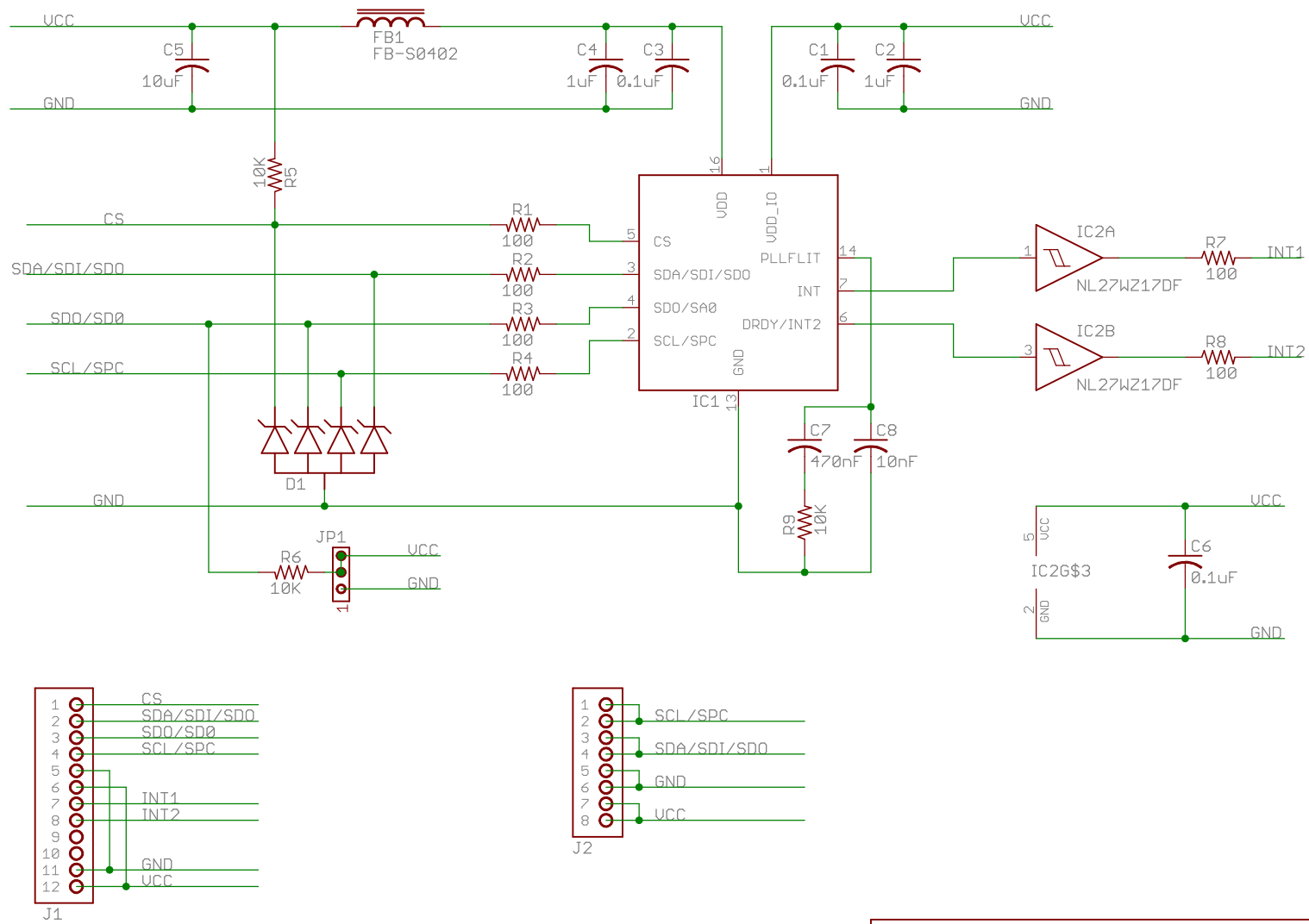

<h2 style="text-align: center;">PmodGYRO</h2> <p style="text-align: center;">Copyright 2011, Digilent Inc.</p>		Engineer: NEA
		Author: PA
SHEET:		Rev: A
TITLE: PmodGYRO		Date: 3/31/2011
Doc#: 500-215	Date: 3/31/2011	Sheet: 1/1