

PmodAD1™ Reference Manual

Revised April 15, 2016

This manual applies to the PmodAD1 rev. G

Overview

The Digilent PmodAD1 is a two channel 12-bit analog-to-digital converter that features Analog Devices [AD7476A](#). With a sampling rate of up to 1 million samples per second, this Pmod is capable of excelling in even the most demanding audio applications.

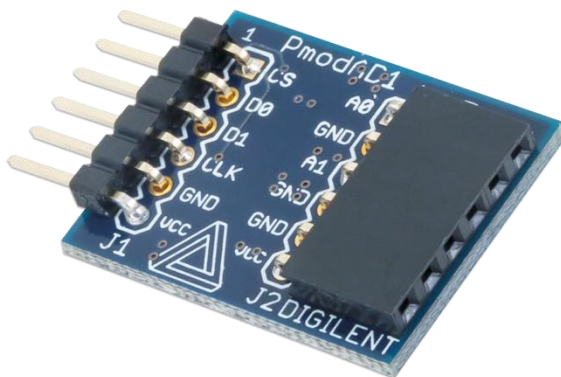

The PmodAD1.

Features include:

- Two channel 12-bit analog-to-digital converter
- Simultaneous A/D conversion at up to one MSa per channel
- Two 2-pole Sallen-Key anti-alias filters
- Small PCB size for flexible designs 0.95 in × 0.8 in (2.4 cm × 2.0 cm)
- 6-pin Pmod port with GPIO interface
- Library and example code available in resource center

1 Interfacing with the Pmod

The PmodAD1 communicates with the host board via an SPI-like communication protocol. The difference between the standard SPI protocol and this protocol is manifested in the pin arrangement on this Pmod. A typical SPI interface would expect a Chip Select, a Master-Out-Slave-In, a Master-in-Slave-Out, and a Serial Clock signal. However, with the two ADCs on this chip, both of the data lines (MOSI and MISO) are designed to operate only as outputs, making them both Master-In-Slave-Out data lines.

The PmodAD1 will provide its 12 bits of information to the system board through 16 clock cycles with first four bits consisting of four leading zeroes and the remaining 12 bits representing the 12 bits of the data with the MSB first. The first leading zero is clocked out on the falling edge of the CS signal with all of the subsequent bits clocked out on the falling edge of the serial clock signal.

A pinout table and diagram for the PmodAD1 are provided below:

Header J1		
Pin	Signal	Description
1	CS	Chip Select
2	D0	Input Data 1
3	D1	Input Data 2
4	SCK	Serial Clock
5	GND	Power Supply Ground
6	VCC	Power Supply (3.3V/5V)

Header J2		
Pin	Signal	Description
1	A0	Input Data 1
2	GND	Power Supply Ground
3	A1	Input Data 2
4	GND	Power Supply Ground
5	GND	Power Supply Ground
6	VCC	Positive Power Supply

Table 1. Pin descriptions as labeled on the PmodAD1.

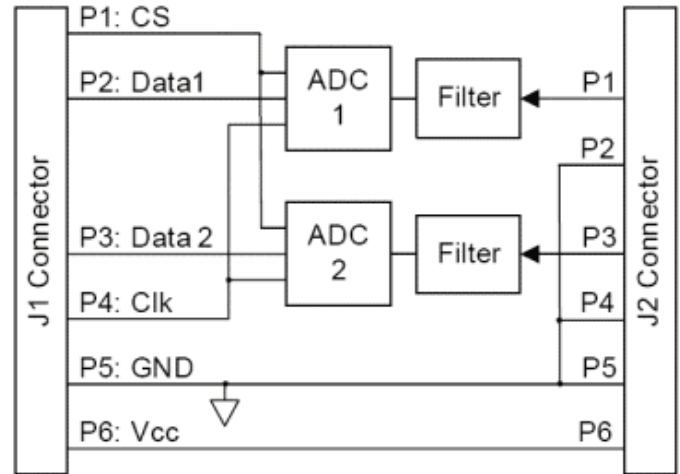
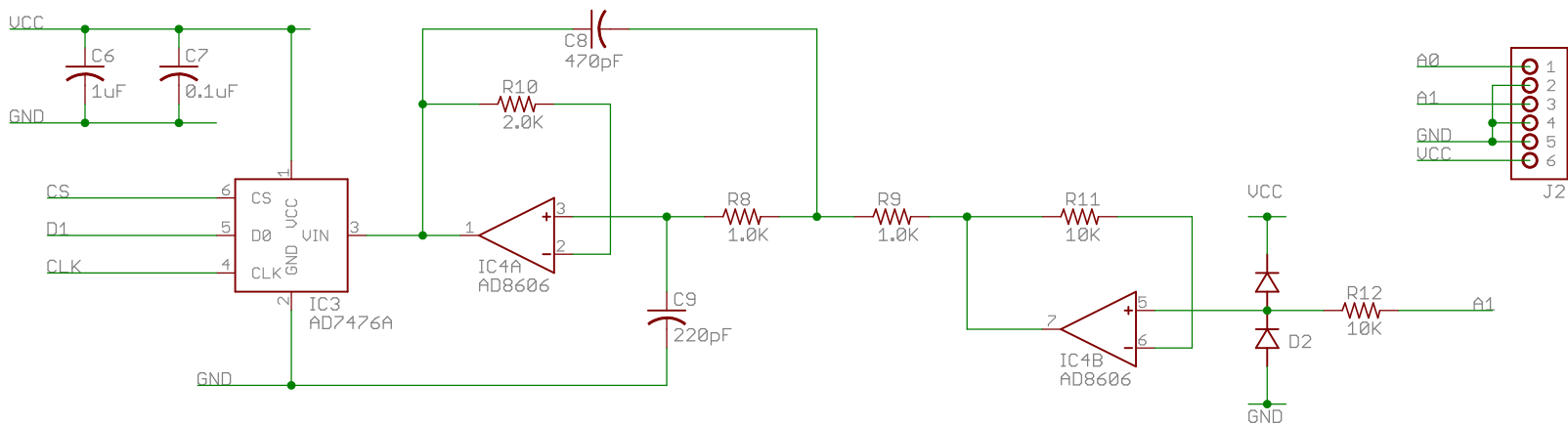
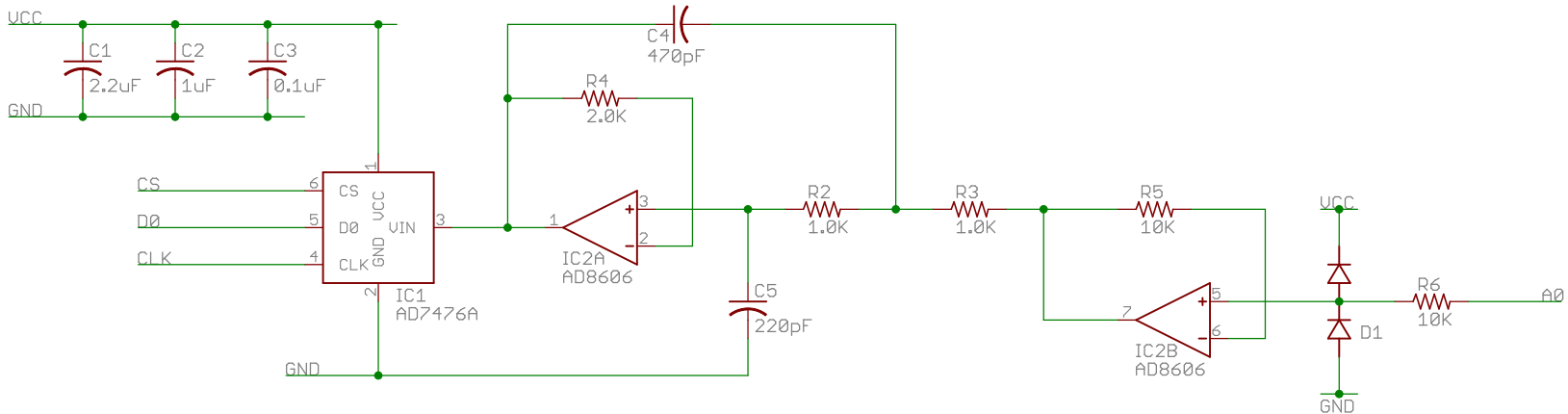
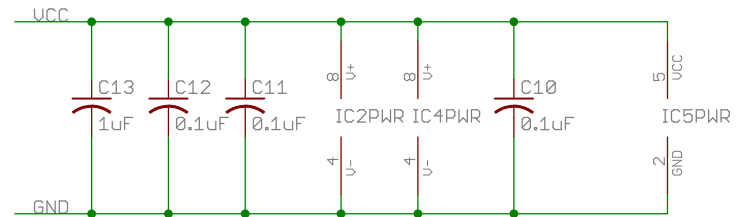
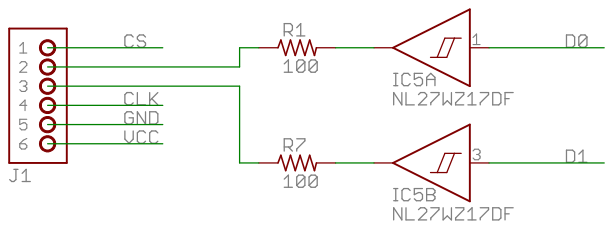

Figure 1. AD1 circuit diagram.

Any external power applied to the PmodAD1 must be within 2.35 to 5.25 volts to ensure that all of the components in the PmodAD1 work correctly.

2 Physical Dimensions

The pins on the pin header are spaced 100 mil apart. The PCB is 0.95 inches long on the sides parallel to the pins on the pin header and 0.80 inches long on the sides perpendicular to the pin header.



For more information on the parts used in this design, please refer to:
www.analog.com/AD7476A - 1-Channel, 12-bit, 1 MSPS, Low-Power A/D Converter
www.analog.com/AD8606 - Precision, Low Noise, CMOS, Rail-to-Rail, Operational Amplifier

PmodAD1		Engineer: NEA
Copyright 2004, 2005, 2011 Digilent Inc.		Author: PA
TITLE: PmodAD1		Rev: G.1
Document Number: 500-064		Sheet: 1/1
Release Date: 12/01/2011		