



**FTDI  
Chip**



**Future Technology Devices International Ltd**

**TTL-232R**    **CE** **FC**

# **TTL to USB Serial Converter Range of Cables Datasheet**

**Document Reference No.: FT\_000054**

**Version 2.01**

**Issue Date: 2008-08-28**

**Future Technology Devices International Ltd (FTDI)**

**373 Scotland Street, Glasgow G5 8QB United Kingdom**

**Tel.: +44 (0) 141 429 2777    Fax: + 44 (0) 141 429 2758**

**E-Mail (Support): support1@ftdichip.com    Web: <http://www.ftdichip.com>**

Neither the whole nor any part of the information contained in, or the product described in this manual, may be adapted or reproduced in any material or electronic form without the prior written consent of the copyright holder. This product and its documentation are supplied on an as-is basis and no warranty as to their suitability for any particular purpose is either made or implied. Future Technology Devices International Ltd will not accept any claim for damages howsoever arising as a result of use or failure of this product. Your statutory rights are not affected. This product or any variant of it is not intended for use in any medical appliance, device or system in which the failure of the product might reasonably be expected to result in personal injury. This document provides preliminary information that may be subject to change without notice. No freedom to use patents or other intellectual property rights is implied by the publication of this document. Future Technology Devices International Ltd, 373 Scotland Street, Glasgow G5 8QB United Kingdom. Scotland Registered Number: SC136640

## 1 Description

The **TTL-232R** cables are a family of USB to TTL serial UART converter cables incorporating FTDI's FT232RQ USB to Serial UART interface IC device which handles all the USB signalling and protocols. The cables provide a fast, simple way to connect devices with a TTL level serial interface to USB.

Each TTL-232R cable contains a small internal electronic circuit board, utilising the FT232R, which is encapsulated into the USB connector end of the cable. The FT232R datasheet, [DS\\_FT232R](http://www.ftdichip.com), is available at <http://www.ftdichip.com>. The other end of the cable comes with a selection of different connectors supporting various applications – see Table 1.1

Cables are FCC, CE, RoHS compliant and are available at TTL levels of +5V and +3.3V.

Cables are available with either a 6-way SIL,0.1" pitch connector, a 3.5mm Audio Jack, an 8 way, keyed 2mm pitch connector (intended for use with VMUSIC2 or VDRIVE2) or bare, tinned wire ended connections (see Table 1.1)

The USB side of the cable is USB powered and USB 2.0 full speed compatible. Each cable is 1.8m long and supports a data transfer rate up to 3 Mbaud. Each cable supports the FTDIChip-ID™, with a unique USB serial number programmed into the FT232R. This feature can be used to create a security or password protected file transfer access using the cable. Further information and examples on this feature are available at <http://www.ftdichip.com> under [FTDIChip-ID Projects](#).

The TTL-232R cables require USB drivers, available free from <http://www.ftdichip.com>, which are used to make the FT232R in the cable appear as a virtual COM port (VCP). This then allows the user to communicate with the USB interface via a standard PC serial emulation port (for example TTY). Another FTDI USB driver, the D2XX driver, can also be used with application software to directly access the FT232R on the cable through a DLL. This is illustrated in the Figure 1.1

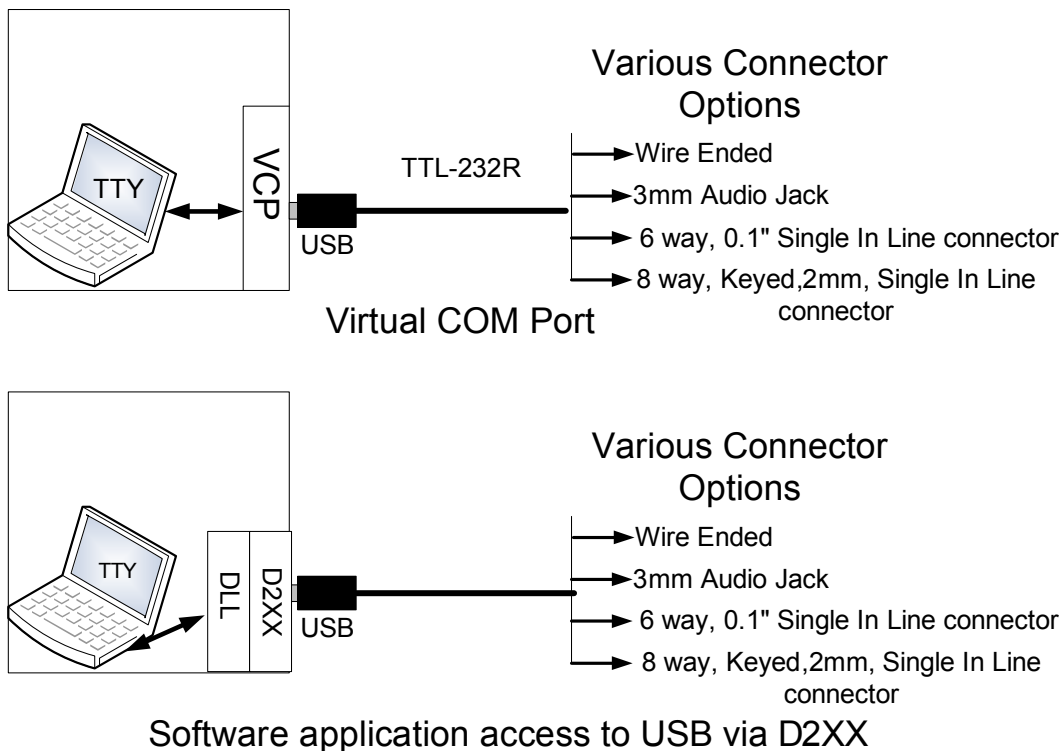

**Figure 1.1 Using the TTL-232R Cable**

## 1.1 Available Cables and Part Numbers

The following Table 1.1 gives details of the available TTL-232R cables.

Part Number	Description	End Connector*	Cable details
TTL-232R-5V**	USB to UART cable with +5V TTL level UART signals.	6 pin SIL, 0.1" pitch	6 core, UL2464 24 AWG, diam=5mm
TTL-232R-3V3	USB to UART cable with +3.3V TTL level UART signals.	6 pin SIL, 0.1" pitch	6 core, UL2464 24 AWG, diam=5mm
TTL-232R-5V-WE**	USB to UART cable with +5V TTL level UART signals.	Wire Ended (no connector)	6 core, UL2464 24 AWG, diam=5mm
TTL-232R-3V3-WE	USB to UART cable with +3.3V TTL level UART signals.	Wire Ended (no connector)	6 core, UL2464 24 AWG, diam=5mm
TTL-232R-5V-AJ**	USB to UART cable with +5V TTL level UART signals.	3.5mm Audio Jack	2 core and spiral, 24 AWG diam=5mm
TTL-232R-3V3-AJ	USB to UART cable with +3.3V TTL level UART signals.	3.5mm Audio Jack	2 core and spiral, 24 AWG diam=5mm
TTL-232R-3V3-2mm	USB to UART cable with +3.3V TTL level UART signals.	8 way, keyed, 2mm connector for use with FTDI VDRIVE2 or VMUSIC2 modules	7 core, UL2464 26 AWG, diam=5mm

**Table 1.1 TTL-232R Cables Descriptions and Part Numbers**

\* FTDI supports customised end connector designs. For more information, please contact FTDI Sales Team (sales1@ftdichip.com)

\*\* These cables are identical to cables which do not have the "5V" in the part number. The 5V was added to the part number for clarity.

## 1.2 Certifications

FTDI TTL-232R range of cables are fully RoHs compliant as well as CE and FCC certified (with the exception of the TTL-232R-XX-WE cables which have not yet completed FCC and CE testing).



## Table of Contents

<b>1</b>	<b>Description .....</b>	<b>1</b>
1.1	<b>Available Cables and Part Numbers.....</b>	<b>2</b>
1.2	<b>Certifications.....</b>	<b>2</b>
<b>2</b>	<b>Typical Applications.....</b>	<b>4</b>
2.1	<b>Driver Support .....</b>	<b>4</b>
2.2	<b>Features.....</b>	<b>5</b>
<b>3</b>	<b>Features of FT232R applicable toTTL-232R Cables .....</b>	<b>6</b>
<b>4</b>	<b>TTL-232R-5V and TTL-232R-3V3 Cables .....</b>	<b>7</b>
4.1	<b>TTL-232R-5V, TTL-232R-3V3 Connector Pin Out and Mechanical details .....</b>	<b>7</b>
4.2	<b>TTL-232R-5V and TTL-232R-3V3 Cable Signal Descriptions .....</b>	<b>7</b>
4.3	<b>TTL-232R-5V and TTL-232R-3V3 Electrical Parameters.....</b>	<b>8</b>
4.3.1	TTL-232R-5V Electrical Parameters .....	8
4.3.2	TTL-232R-3V3 Electrical Parameters .....	8
<b>5</b>	<b>TTL-232R-5V-AJ and TTL-232R-3V3-AJ .....</b>	<b>10</b>
5.1	<b>TTL-232R-5V-AJ, TTL-232R-3V3-AJ Connector Pin Out and Mechanical details .....</b>	<b>10</b>
5.2	<b>TTL-232R-5V-AJ and TTL-232R-3V3-AJ Cable Signal Descriptions .....</b>	<b>11</b>
5.3	<b>TTL-232R-5V-AJ and TTL-232R-3V3-AJ Electrical Parameters.....</b>	<b>11</b>
5.3.1	TTL-232R-5V-AJ Electrical Parameters.....	11
5.3.2	TTL-232R-3V3-AJ Electrical Parameters.....	12
<b>6</b>	<b>TTL-232R-5V-WE and TTL-232R-3V3-WE Cables .....</b>	<b>13</b>
6.1	<b>TTL-232R-5V-WE, TTL-232R-3V3-WE Connections and Mechanical Details</b>	<b>13</b>
6.2	<b>TTL-232R-5V-WE and TTL-232R-3V3-WE Cable Signal Descriptions.....</b>	<b>13</b>
6.3	<b>TTL-232R-5V-WE and TTL-232R-3V3-WE Electrical Parameters .....</b>	<b>13</b>
6.3.1	TTL-232R-5V-WE Electrical Parameters .....	14
6.3.2	TTL-232R-3V3-WE Electrical Parameters .....	14
<b>7</b>	<b>TTL-232R-3V3-2mm Cables .....</b>	<b>15</b>
7.1	<b>TTL-232R-3V3-2mm Connector Pin Out and Mechanical details .....</b>	<b>15</b>
7.2	<b>TTL-232R-3V3-2mm Cable Signal Descriptions .....</b>	<b>16</b>
7.3	<b>TTL-232R-3V3-2mm Electrical Parameters.....</b>	<b>16</b>
<b>8</b>	<b>Cable PCB Circuit Schematic .....</b>	<b>17</b>
<b>9</b>	<b>Contact Information .....</b>	<b>18</b>
	<b>Appendix A - Cable EEPROM Configuration.....</b>	<b>19</b>
	<b>Appendix B - List of Figures and Tables.....</b>	<b>21</b>
	<b>Appendix C - Revision History .....</b>	<b>22</b>

## 2 Typical Applications

- USB to Serial TTL Level Converter
- Upgrading Legacy Peripherals to USB
- Interface Microcontroller UART or I/O to USB
- Interface FPGA / PLD to USB
- Interface to FTDI VDRIVE2 or VMUSIC2 modules.
- Replace MAX232 type level shifters allowing for direct connection of products to PC via USB
- USB Instrumentation PC interface
- USB Industrial Control
- USB Software / Hardware Encryption Dongles

### 2.1 Driver Support

#### Royalty free VIRTUAL COM PORT (VCP) DRIVERS for...

- Windows 98, 98SE, ME, 2000, Server 2003, XP and Server 2008
- Windows XP and XP 64-bit
- Windows Vista and Vista 64-bit
- Windows XP Embedded
- Windows CE 4.2, 5.0 and 6.0
- Mac OS 8/9, OS-X
- Linux 2.4 and greater

#### Royalty free D2XX *Direct Drivers* (USB Drivers + DLL S/W Interface)

- Windows 98, 98SE, ME, 2000, Server 2003, XP and Server 2008
- Windows XP and XP 64-bit
- Windows Vista and Vista 64-bit
- Windows XP Embedded
- Windows CE 4.2, 5.0 and 6.0
- Linux 2.4 and greater

The drivers listed above are all available to download for free from [www.ftdichip.com](http://www.ftdichip.com). Various 3rd Party Drivers are also available for various other operating systems - see [www.ftdichip.com](http://www.ftdichip.com) for details.

## 2.2 Features

- TTL-232R Converter Cable provides a USB to TTL Serial interface with various end connectors.
- On board FT232RQ provides single chip USB to asynchronous serial data transfer interface.
- Entire USB protocol handled by the electronics in the cable USB.
- Connect directly to a microcontroller UART or I/O pins.
- UART interface support for 7 or 8 data bits, 1 or 2 stop bits and odd / even / mark / space / no parity.
- Fully assisted hardware (RTS#/CTS#) or X-On / X-Off software handshaking.
- Data transfer rates from 300 baud to 3 Mbaud at TTL levels.
- Internal EEPROM with user writeable area.
- 5V CMOS drive outputs and 5V safe TTL inputs makes the TTL-232R easy to interface to 5V MCU's.
- FTDI's royalty-free VCP allow for communication as a standard emulated COM port and D2XX 'direct' drivers provide DLL application programming interface.
- Support for FT232R FTDIChip-ID™ feature for improved security.
- +5V or +3.3V output allows external logic to be powered from the USB port.
- 6 way outputs provide Tx, Rx, RTS#, CTS#, VCC and GND (except Audio Jack which provides only TX,RX and GND).
- 8 way, keyed connector to support FTDI VDRIVE2 and VMUSIC2.
- 3 way Audio Jack connector provides Tx, Rx and GND.
- Low USB bandwidth consumption.
- UHCI / OHCI / EHCI host controller compatible.
- USB 2.0 Full Speed compatible.
- -40°C to +85°C operating temperature range.
- Cable length is 1.80m (6 feet).
- FCC and CE compliant.
- Custom versions also available (subject to MOQ).

### 3 Features of FT232R applicable toTTL-232R Cables

The TTL-232R cables use FTDI's FT232RQ USB to serial IC device. This section summarises the key features of the FT232RQ which apply to the TTL-232R USB to serial TTL converter cables. For further details, and a full features and enhancements description consult the FT232R datasheet, this is available from [www.ftdichip.com](http://www.ftdichip.com).

**Internal EEPROM.** The internal EEPROM in each cable is used to store USB Vendor ID (VID), Product ID (PID), device serial number, product description string and various other USB configuration descriptors. Each cable is supplied with the internal EEPROM pre-programmed as described in **Appendix A - Cable EEPROM Configuration**. A user area of the internal EEPROM is available to system designers to allow storing additional data. The internal EEPROM descriptors can be programmed in circuit, over USB without any additional voltage requirement. It can be programmed using the FTDI utility software called MPROG, which can be downloaded from FTDI Utilities on the FTDI website ([www.ftdichip.com](http://www.ftdichip.com)).

**Lower Operating and Suspend Current.** The FT232R has a low 15mA operating supply current and a very low USB suspend current of approximately 70µA. (Note that during suspend mode, the current drawn by application should not exceed 2.5mA to remain USB compliant)

**Low USB Bandwidth Consumption.** The USB interface of the FT232R, and therefore the TTL-232R cables has been designed to use as little as possible of the total USB bandwidth available from the USB host controller.

**High Output Drive Option.** The UART interface I/O pins on the TTL-232R cables (RXD, TXD, RTS#, and CTS#) can be configured to use the FT232R's high output drive option. This option allows the FT232R I/O pins to drive up to three times the standard signal drive level. This allows multiple devices to be driven, or devices that require a greater signal drive strength to be interfaced to the cables. This option is enabled in the internal EEPROM.

**UART Pin Signal Inversion.** The sense of each of the eight UART signals can be individually inverted by configuring options in the internal EEPROM. For example CTS# (active low) can be changed to CTS (active high), or TXD can be changed to TXD#.

**FTDICHIP-ID™.** The FT232R includes the new FTDICHIP-ID™ security dongle feature. This FTDICHIP-ID™ feature allows a unique number to be burnt into each cable during manufacture. This number cannot be reprogrammed. This number is only readable over USB can be used to form the basis of a security dongle which can be used to protect any customer application software being copied. This allows the possibility of using the TTL-232R cables as a dongle for software licensing. Further to this, a renewable license scheme can be implemented based on the FTDICHIP-ID™ number when encrypted with other information. This encrypted number can be stored in the user area of the FT232R internal EEPROM, and can be decrypted, then compared with the protected FTDICHIP-ID™ to verify that a license is valid. Web based applications can be used to maintain product licensing this way. An application note, AN232R-02, available from FTDI website ([www.ftdichip.com](http://www.ftdichip.com)) describes this feature.

**Improved EMI Performance.** The TTL-232R cables are FCC and CE certified.

**Extended Operating Temperature Range -** The TTL-232R cables are capable of operating over an extended temperature range of -40° to +85° C thus allowing them to be used in automotive or industrial applications.

## 4 TTL-232R-5V and TTL-232R-3V3 Cables

The TTL-232R-5V and TTL-232R-3V3 cables are both terminated by a 6 way, 0.1", Single-In-Line (SIL) connector. The difference between the two cables is that the TTL-232R-5V operates at +5V levels (signals and power supply) and the TTL-232R-3V3 operates at +3.3V levels (signals only, VCC= +5V).

### 4.1 TTL-232R-5V, TTL-232R-3V3 Connector Pin Out and Mechanical details

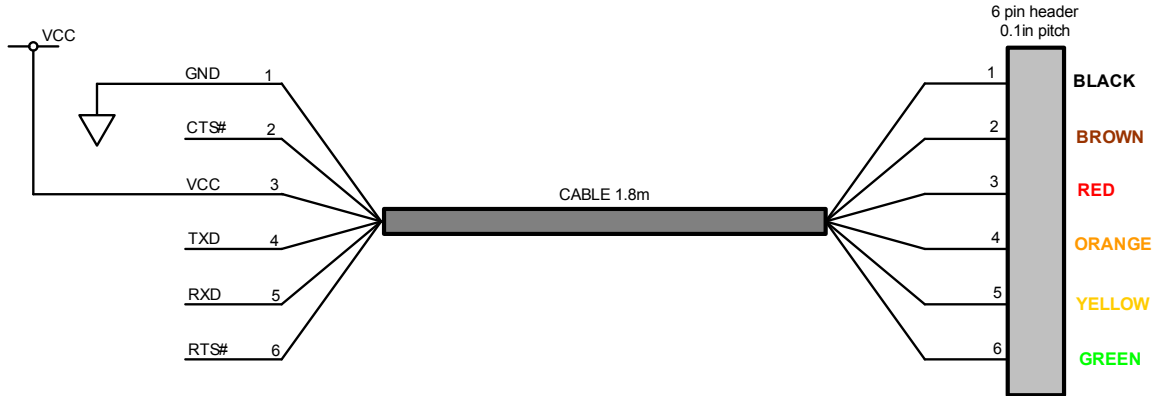

Figure 4.1 TTL-232R-5V and TTL-232R-3V3, 6 Way Header Pin Out

The mechanical details of the 6 way connector are shown in the following diagram

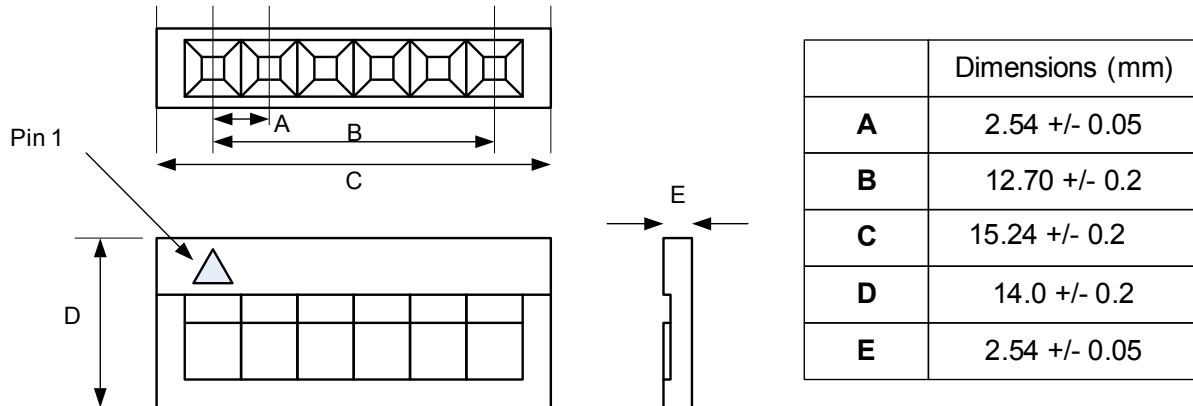

Figure 4.2 TTL-232R-5V TTL-232R-3V3, 6 Way Header Mechanical Details

### 4.2 TTL-232R-5V and TTL-232R-3V3 Cable Signal Descriptions

Header Pin Number	Name	Type	Colour	Description
1	GND	GND	Black	Device ground supply pin.
2	CTS#	Input	Brown	Clear to Send Control input / Handshake signal.
3	VCC	Output	Red	+5V output,



Header Pin Number	Name	Type	Colour	Description
4	TXD	Output	Orange	Transmit Asynchronous Data output.
5	RXD	Input	Yellow	Receive Asynchronous Data input.
6	RTS#	Output	Green	Request To Send Control Output / Handshake signal.

**Table 4.1 TTL-232R-5V and TTL-232R-3V3 Cable Signal Descriptions**

### 4.3 TTL-232R-5V and TTL-232R-3V3 Electrical Parameters

#### 4.3.1 TTL-232R-5V Electrical Parameters

Parameter	Description	Minimum	Typical	Maximum	Units	Conditions
VCC	Output Power Voltage	4.25	5.0	5.25	V	Dependant on the USB port that the TTL-232R-5V is connected to
I <sub>o</sub>	Output Power Current	-	-	75	mA	Must be less that 2.5mA during suspend.
T	Operating Temperature Range	-40	-	+85	°C	

**Table 4.2 TTL-232R-5V I/O Operating Parameters**

Parameter	Description	Minimum	Typical	Maximum	Units	Conditions
V <sub>oh</sub>	Output Voltage High	3.2	4.1	4.9	V	I source = 6mA
V <sub>ol</sub>	Output Voltage Low	0.3	0.4	0.6	V	I sink = 6mA
V <sub>in</sub>	Input Switching Threshold	1.0	1.2	1.5	V	
V <sub>Hys</sub>	Input Switching Hysteresis	20	25	30	mV	

**Table 4.3 TTL-232R-5V I/O Pin Characteristics**

#### 4.3.2 TTL-232R-3V3 Electrical Parameters

Parameter	Description	Minimum	Typical	Maximum	Units	Conditions
VCC	Output Power Voltage	4.25	5.0	5.25	V	Dependant on the USB port that the TTL-232R-3V3 is connected to
I <sub>o</sub>	Output Power Current	-	-	75	mA	Must be less that 2.5mA during suspend.
T	Operating Temperature Range	-40	-	+85	°C	

**Table 4.4 TTL-232R-3V3 I/O Operating Parameters**

Parameter	Description	Minimum	Typical	Maximum	Units	Conditions
Voh	Output Voltage High	2.2	2.8	3.2	V	I source = 3mA
Vol	Output Voltage Low	0.3	0.4	0.6	V	I sink = 8mA
Vin	Input Switching Threshold	1.0	1.2	1.5	V	
VHys	Input Switching Hysteresis	20	25	30	mV	

**Table 4.5 TTL-232R-3V3 I/O Pin Characteristics**

## 5 TTL-232R-5V-AJ and TTL-232R-3V3-AJ

The TTL-232R-5V-AJ and TTL-232R-3V3-AJ cables are both terminated by a standard 3.5mm Audio Jack (AJ) connector. The difference between the two cables is that the TTL-232R-5V-AJ operates at +5V levels (signals and power supply) and the TTL-232R-3V3-AJ operates at +3.3V levels (signals and power supply). On these cables the VCC power is not transferred.

### 5.1 TTL-232R-5V-AJ, TTL-232R-3V3-AJ Connector Pin Out and Mechanical details

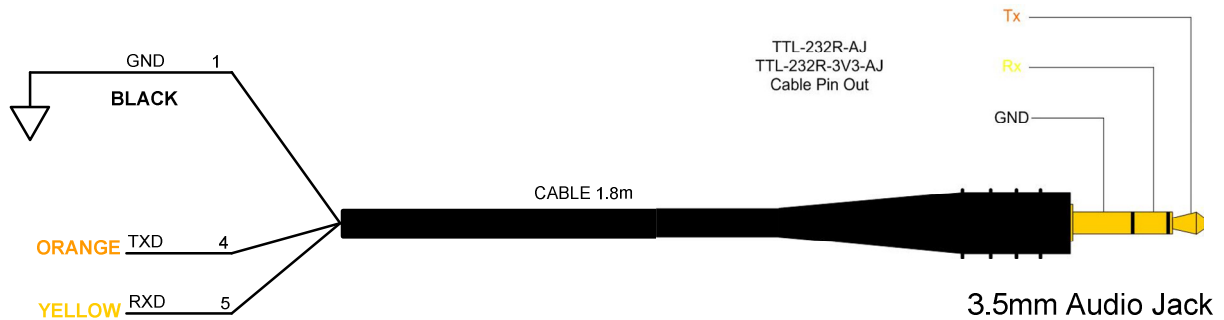

**Figure 5.1 TTL-232R-5V and TTL-232R-3V3, 6 Way Header Pin Out**

The mechanical details of the Audio Jack connector are shown in the following **Figure 5.2**.

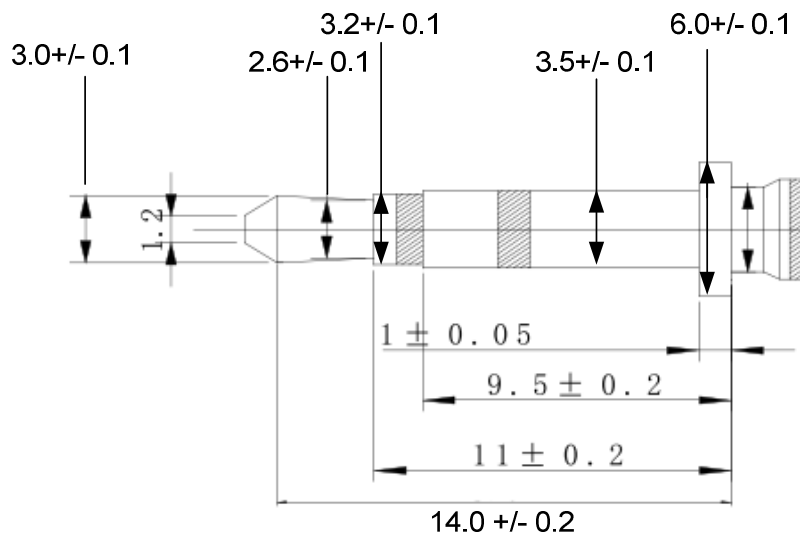

Dimensions in mm

**Figure 5.2 TTL-232R-5V-AJ and TTL-232R-3V3-AJ Audio Jack Mechanical Details**

## 5.2 TTL-232R-5V-AJ and TTL-232R-3V3-AJ Cable Signal Descriptions

Header Pin Number	Name	Type	Colour	Description
TIP	TXD	GND	Black	Transmit Asynchronous Data output.
RING	RXD	Input	Brown	Receive Asynchronous Data input.
SLEEVE	GND	Output	Red	GND

**Table 5.1 TTL-232R-5V-AJ and TTL-232R-3V3-AJ Cable Signal Descriptions**

## 5.3 TTL-232R-5V-AJ and TTL-232R-3V3-AJ Electrical Parameters

### 5.3.1 TTL-232R-5V-AJ Electrical Parameters

Parameter	Description	Minimum	Typical	Maximum	Units	Conditions
$I_o$	Output Power Current	-		75	mA	Must be less than 2.5mA during suspend.
T	Operating Temperature Range	-40		+85	°C	

**Table 5.2 TTL-232R-5V-AJ I/O Operating Parameters**

Parameter	Description	Minimum	Typical	Maximum	Units	Conditions
Voh	Output Voltage High	3.2	4.1	4.9	V	I source = 6mA
Vol	Output Voltage Low	0.3	0.4	0.6	V	I sink = 6mA
Vin	Input Switching Threshold	1.0	1.2	1.5	V	
VHys	Input Switching Hysteresis	20	25	30	mV	

**Table 5.3 TTL-232R-5V-AJ I/O Pin Characteristics**

### 5.3.2 TTL-232R-3V3-AJ Electrical Parameters

Parameter	Description	Minimum	Typical	Maximum	Units	Conditions
I <sub>o</sub>	Output Power Current	-		75	mA	Must be less than 2.5mA during suspend.
T	Operating Temperature Range	-40		+85	°C	

**Table 5.4 TTL-232R-3V3-AJ I/O Operating Parameters**

Parameter	Description	Minimum	Typical	Maximum	Units	Conditions
V <sub>oh</sub>	Output Voltage High	2.2	2.8	3.2	V	I source = 3mA
V <sub>ol</sub>	Output Voltage Low	0.3	0.4	0.6	V	I sink = 8mA
V <sub>in</sub>	Input Switching Threshold	1.0	1.2	1.5	V	
V <sub>Hys</sub>	Input Switching Hysteresis	20	25	30	mV	

**Table 5.5 TTL-232R-3V3-AJ I/O Pin Characteristics**

## 6 TTL-232R-5V-WE and TTL-232R-3V3-WE Cables

The TTL-232R-5V-WE and TTL-232R-3V3-WE cables are both un-terminated; they are bare and tinned wires. The difference between the two cables is that the TTL-232R-5V-WE operates at +5V levels (signals and power supply) and the TTL-232R-3V3-WE operates at +3.3V levels (signals only, VCC=+5V).

### 6.1 TTL-232R-5V-WE, TTL-232R-3V3-WE Connections and Mechanical Details

The following Figure 6.1 shows the cable signals and the wire colours for these signals on the TTL-232R-5V-WE and TTL-232R-3V3-WE cables.

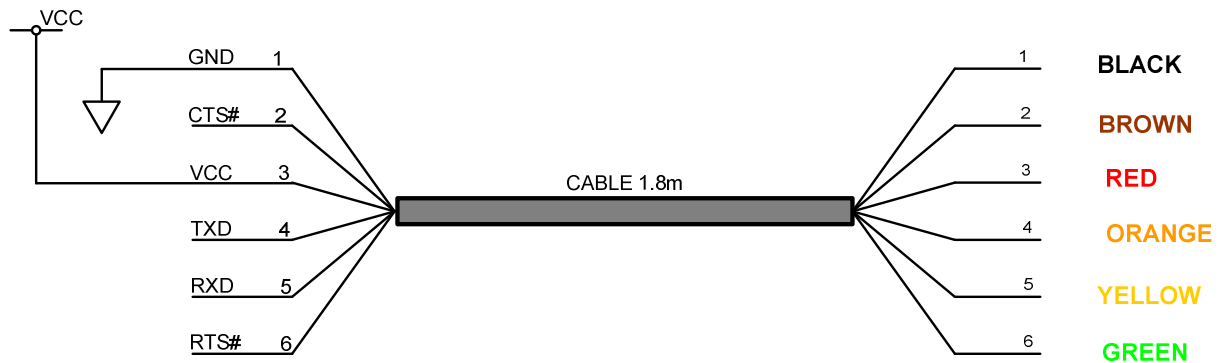

Figure 6.1 TTL-232R-5V-WE and TTL-232R-3V3-WE Connections

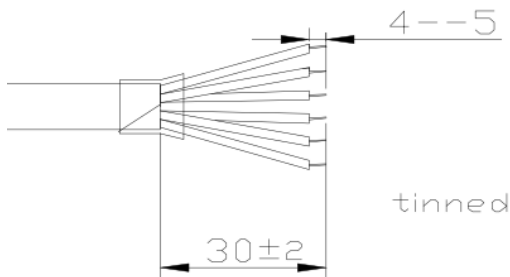

Figure 6.2 TTL-232R-5V-WE and TTL-232R-3V3-WE Mechanical Details (dimensions in mm)

### 6.2 TTL-232R-5V-WE and TTL-232R-3V3-WE Cable Signal Descriptions

Colour	Name	Type	Description
Black	GND	GND	Device ground supply pin.
Brown	CTS#	Input	Clear to Send Control input / Handshake signal.
Red	VCC	Output	+5V output
Orange	TXD	Output	Transmit Asynchronous Data output.
Yellow	RXD	Input	Receive Asynchronous Data input.
Green	RTS#	Output	Request To Send Control Output / Handshake signal.

Table 6.1 TTL-232R-5V-WE and TTL-232R-3V3-WE Cable Signal Descriptions

### 6.3 TTL-232R-5V-WE and TTL-232R-3V3-WE Electrical Parameters

### 6.3.1 TTL-232R-5V-WE Electrical Parameters

Parameter	Description	Minimum	Typical	Maximum	Units	Conditions
VCC	Output Power Voltage	4.25	5.0	5.25	V	Dependant on the USB port that the TTL-232R-5V-WE is connected to
I <sub>o</sub>	Output Power Current	-		75	mA	Must be less that 2.5mA during suspend.
T	Operating Temperature Range	-40		+85	°C	

**Table 6.2 TTL-232R-5V-WE I/O Operating Parameters**

Parameter	Description	Minimum	Typical	Maximum	Units	Conditions
V <sub>oh</sub>	Output Voltage High	3.2	4.1	4.9	V	I source = 6mA
V <sub>ol</sub>	Output Voltage Low	0.3	0.4	0.6	V	I sink = 6mA
V <sub>in</sub>	Input Switching Threshold	1.0	1.2	1.5	V	
V <sub>Hys</sub>	Input Switching Hysteresis	20	25	30	mV	

**Table 6.3 TTL-232R-5V-WE I/O Pin Characteristics**

### 6.3.2 TTL-232R-3V3-WE Electrical Parameters

Parameter	Description	Minimum	Typical	Maximum	Units	Conditions
VCC	Output Power Voltage	4.25	5.0	5.25	V	Dependant on the USB port that the TTL-232R-3V3-WE is connected to
I <sub>o</sub>	Output Power Current	-		75	mA	Must be less that 2.5mA during suspend.
T	Operating Temperature Range	-40		+85	°C	

**Table 6.4 TTL-232R-3V3-WE I/O Operating Parameters**

Parameter	Description	Minimum	Typical	Maximum	Units	Conditions
V <sub>oh</sub>	Output Voltage High	2.2	2.8	3.2	V	I source = 3mA
V <sub>ol</sub>	Output Voltage Low	0.3	0.4	0.6	V	I sink = 8mA
V <sub>in</sub>	Input Switching Threshold	1.0	1.2	1.5	V	
V <sub>Hys</sub>	Input Switching Hysteresis	20	25	30	mV	

**Table 6.5 TTL-232R-3V3-WE I/O Pin Characteristics**

## 7 TTL-232R-3V3-2mm Cables

The TTL-232R-3V3-2mm cable is terminated by a 8 way, 2mm pitch, Single-In-Line (SIL) keyed connector. The TTL-232R-3V3-2mm operates at +3.3V levels (signals and power supply). These cables are primarily intended for interfacing the FTDI VDRIVE2 and VMUSIC2 modules.

Note that when connected to VDRIVE2 or VMUSIC2 module, the TTL-232R-3V3-2mm cable 8-way connector pin 1 connects to pin 8 of the module, and pin 8 of the cable connects to pin 1 of the cable.

### 7.1 TTL-232R-3V3-2mm Connector Pin Out and Mechanical details

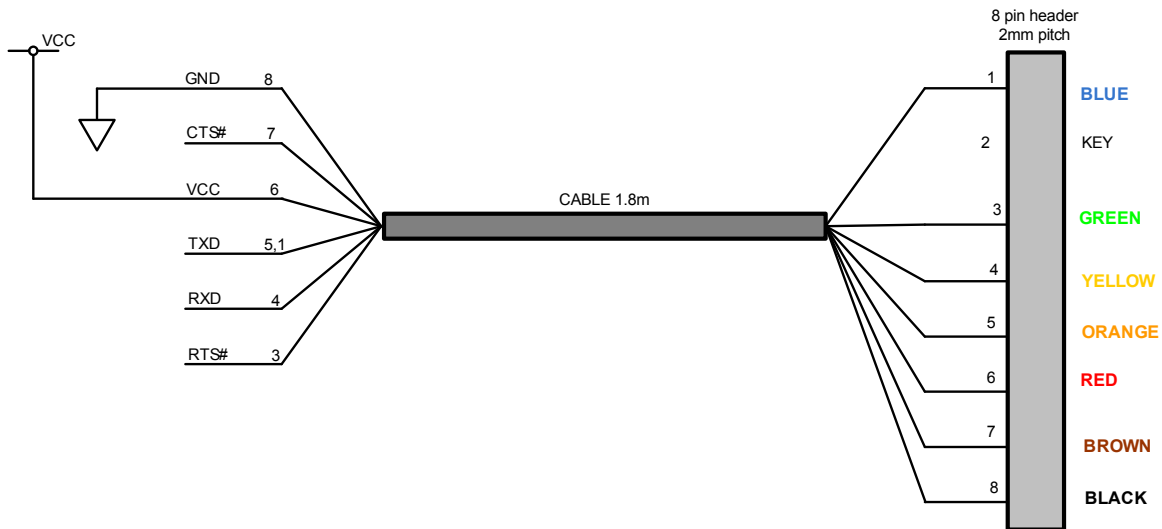

**Figure 7.1 TTL-232R-3V3-2mm, 8 Way Header Pin Out**

The mechanical details of the 2mm pitch 8 way, keyed, connector are shown in the following diagram

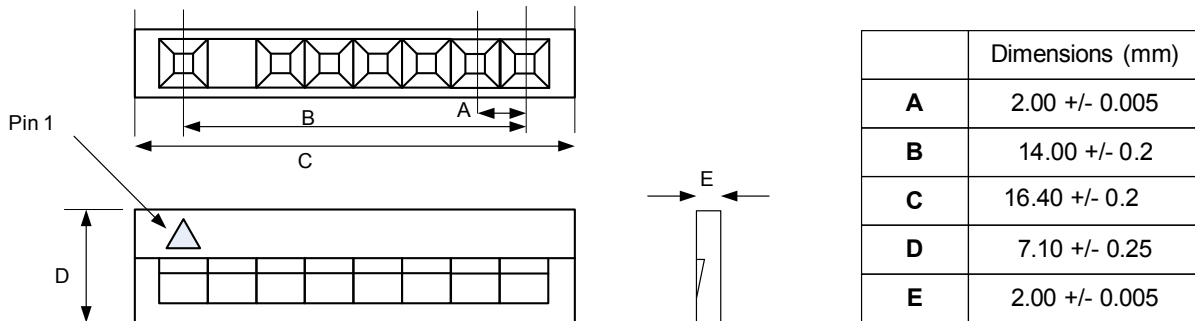

**Figure 7.2 TTL-232R-3V3-2mm, 2mm pitch, Keyed, 8 way Header Mechanical Details**



## 7.2 TTL-232R-3V3-2mm Cable Signal Descriptions

Header Pin Number	Name	Type	Colour	Description
1	RI#	Output	Blue	Ring Indicator Control Input. When remote wake up is enabled taking RI# low (20ms active low pulse) can be used to resume the VMUSIC2 or VDRIVE2 host controller from suspend. Connected to TXD.
2	KEY	KEY	KEY	This connection is keyed to connect to the VRDIVE2 or the VMUSIC2 modules
3	RTS#	Output	Green	Request To Send Control Output / Handshake signal.
4	RXD	Input	Yellow	Receive Asynchronous Data input.
5	TXD	Output	Orange	Transmit Asynchronous Data output.
6	VCC	Output	Red	+5V output,
7	CTS#	Input	Brown	Clear to Send Control input / Handshake signal.
8	GND	GND	Black	Device ground supply pin.

**Table 7.1 TTL-232R-3V3-2mm Cable Signal Descriptions**

## 7.3 TTL-232R-3V3-2mm Electrical Parameters

Parameter	Description	Minimum	Typical	Maximum	Units	Conditions
VCC	Output Power Voltage	4.25	5.0	5.25	V	Dependant on the USB port that the TTL-232R-3V3-2mm is connected to
I <sub>o</sub>	Output Power Current	-		75	mA	Must be less than 2.5mA during suspend.
T	Operating Temperature Range	-40		+85	°C	

**Table 7.2 TTL-232R-3V3-2mm I/O Operating Parameters**

Parameter	Description	Minimum	Typical	Maximum	Units	Conditions
V <sub>oh</sub>	Output Voltage High	2.2	2.8	3.2	V	I source = 3mA
V <sub>ol</sub>	Output Voltage Low	0.3	0.4	0.6	V	I sink = 8mA
V <sub>in</sub>	Input Switching Threshold	1.0	1.2	1.5	V	
V <sub>Hys</sub>	Input Switching Hysteresis	20	25	30	mV	

**Table 7.3 TTL-232R-3V3-2mm I/O Pin Characteristics**