

KEY Coffee Grinder | Quick Start Guide

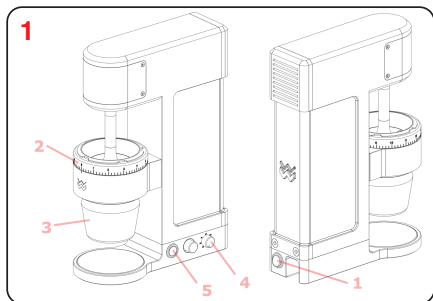

First Steps

1. Turn on the mains power switch
2. Adjust the adjustment ring based on your brewing style, **Do NOT** operate the grinder without the adjustment ring in place
3. Attach the magic tumbler
4. Select desired RPM
5. Press the On/Off button to start the grinder

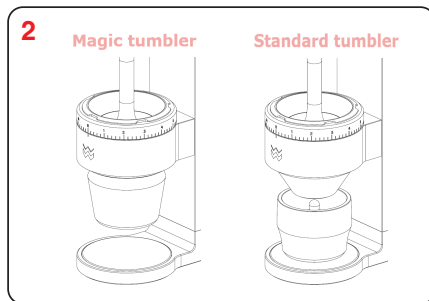

Option 1 - Use as-is (without wiper)

- We recommend using RDT (one spray of water per dose of coffee) to eliminate static electricity. The spritzer is included in the box.

Magic Tumbler

- Attach the magic tumbler to the magnetic mount, being careful not to damage the static wiper or the stirring wire.

Standard Tumbler (Sold Separately)

- Attach the lower funnel on the magnetic mount, then place standard tumbler on the base

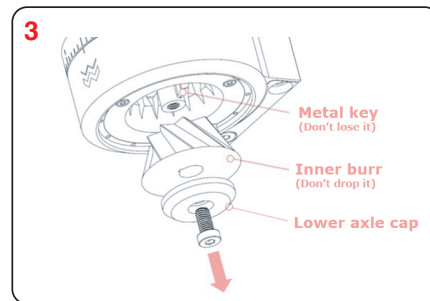

Option 2 - Install wiper (Magic or Standard)

- Choose the correct wiper for your tumbler
- Use the 5mm hex key to remove the bolt holding the inner burr and the lower axle cap in place
- Remove the axle cap and store for safekeeping
- Re-use the bolt and thread it through the metal washer and wiper
- Tighten the bolt securely

If you have difficulty removing the bottom screw refer to **pic. B**.

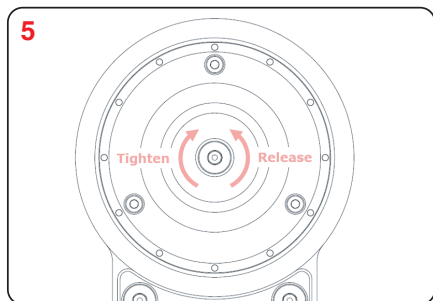
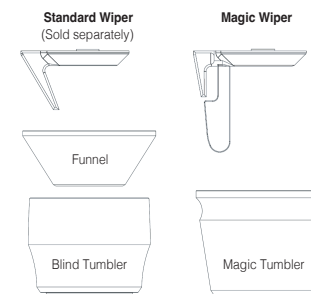
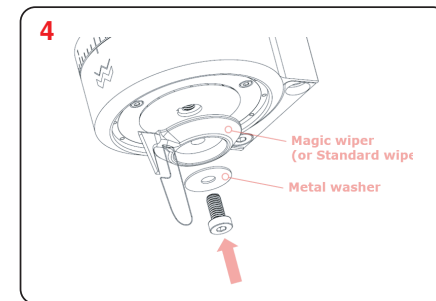

IMPORTANT :

- Please make sure the bolt is tightened securely

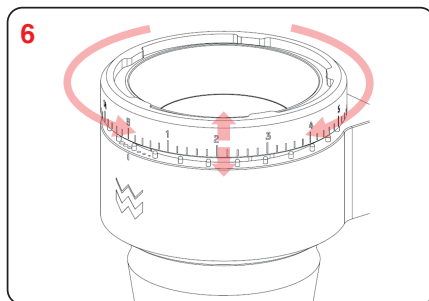

Dial in grind

The KEY ships pre-set to a reasonable grind setting for espresso. You will need to make adjustments for your specific use-case.

IMPORTANT! Verify the locking ring sits flush with the burr collar, and the pins are completely engaged.

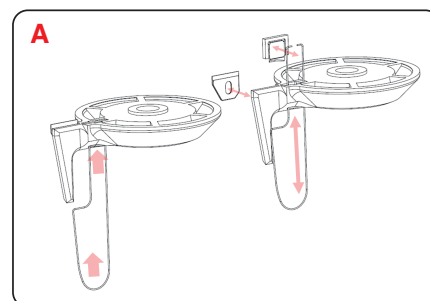

Swap the wiper stirring wire

1. Remove the magic wiper from the grinder
2. Push out the insert block on rear of the wiper
3. Swap the stirring wire and re-insert the block
4. Swap the wiper shim if necessary

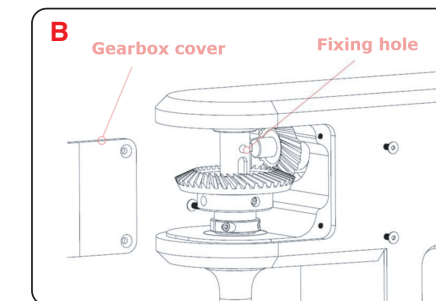

Tip

- Throw a few coffee beans in to add resistance and use a rubber glove to hold the shaft securely. Tapping the end of the allen key abruptly will also help.
- If the bottom bolt is stuck and cannot be removed, remove the gearbox cover and place a metal rod (or Allen key) through the hole in the shaft to lock it in place. Use appropriate protective material to avoid damaging the paint.

