

FIG. A: SCALE GUIDE

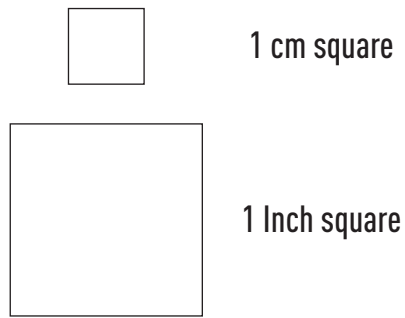

FIG. B: FRONT VIEW - ACTUAL SIZE

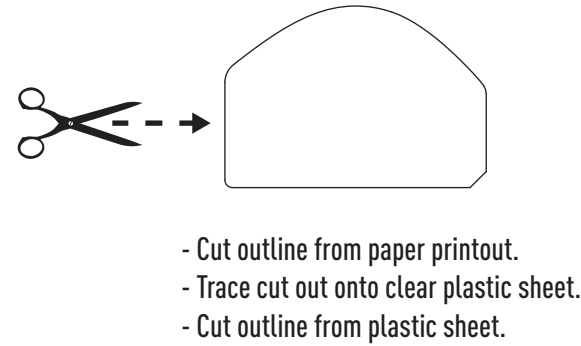
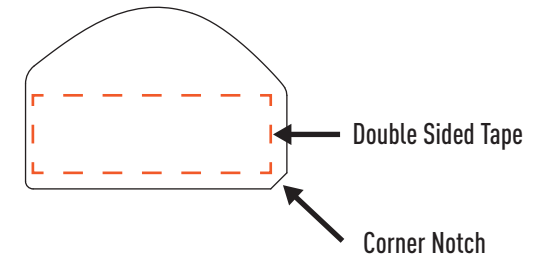
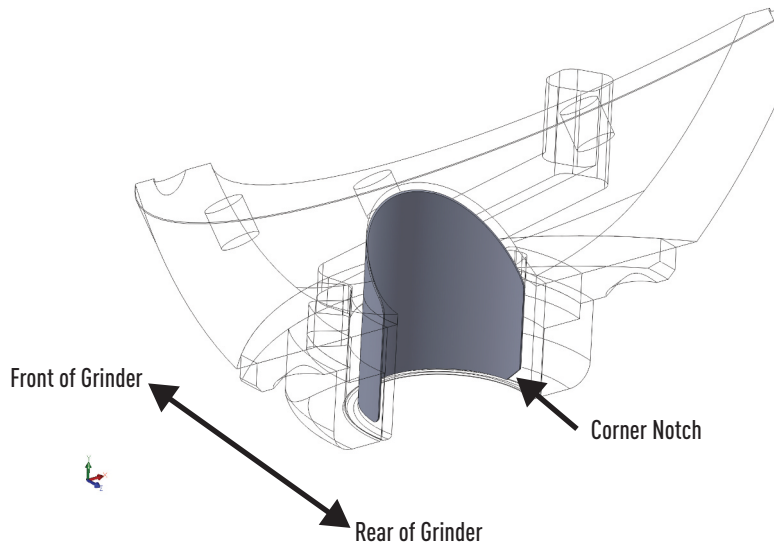

FIG C: FRONT VIEW - APPLY DOUBLE SIDED TAPE



From front facing side apply double sided tape to **rear** side of Spout Wiper.

FIG. D: CROSS SECTION OF LOWER FUNNEL AND CLICKER ASSEMBLY



DIRECTIONS:

1. Print template document. Document is formatted for A4 size paper, **do not scale**. Slight cropping may occur when printing on US Letter size paper. After printing check scale of print with ruler against **FIG. A**
2. Cut out **FIG B.** with scissors. Trace cut out onto clear file plastic, as used with standard stationary paper organizers. Trim outline with scissors.
3. Remove Lower Funnel from EG-1. Using a damp cloth, thoroughly clean part of any residual oils and coffee grounds.
4. Attach double sided tape to **rear** face of wiper as indicated in **FIG C**
5. Attach plastic wiper to Clicker Assembly as illustrated in **FIG. D**
6. Test Clicker before reattaching funnel to ensure top of plastic does not protrude into grind chamber and interfere with path of wiper.

