

进化红

EVO RED

基础线性轴体，轴体出厂薄润。

轴体类型(Characteristics): 线性轴
 轴体寿命(Durability): 5000万次
 触发压力(Operating force): 42±5gf
 触底压力(End force): 60±5gf
 触发行程(Pre-travel): 2.0±0.3mm
 总行程(Total travel): 4.0±0.3mm

润滑油处理工艺

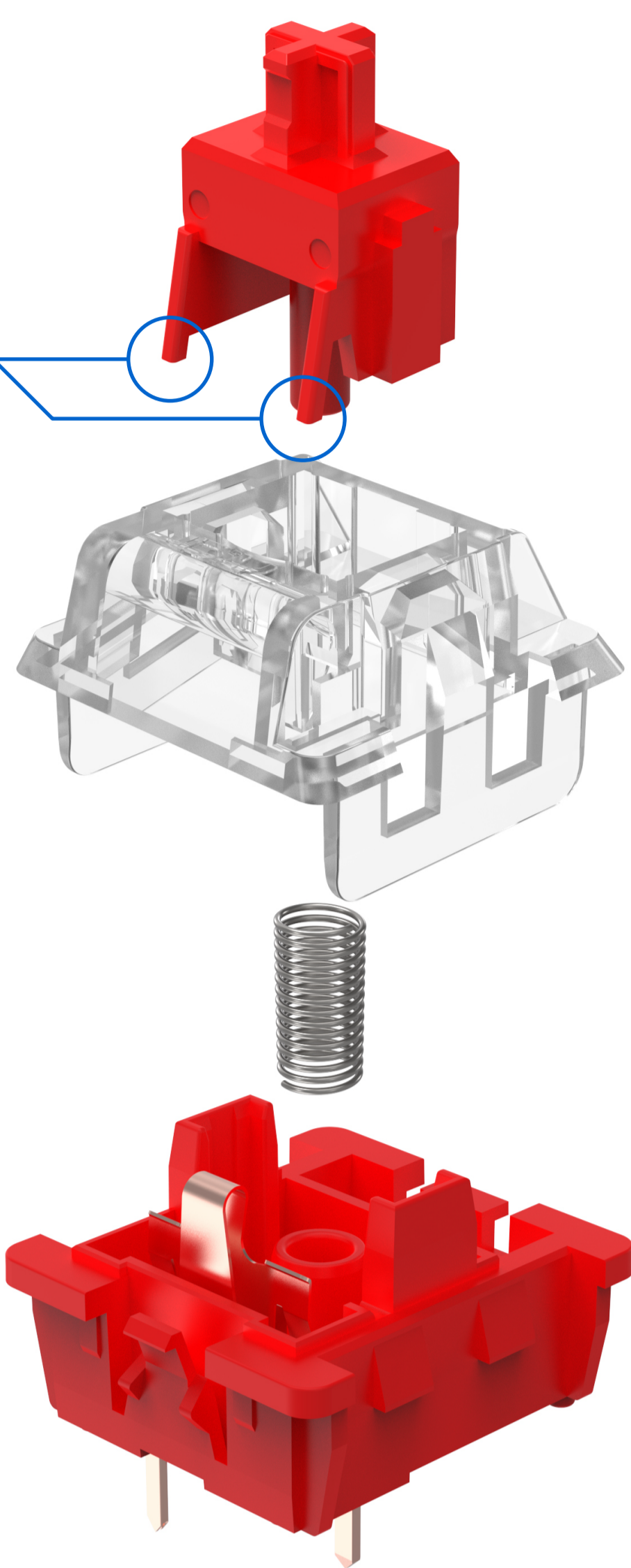

金属铜片与轴心之间接触摩擦位有增加润滑油处理工艺，使轴体更加顺滑，减少摩擦音。

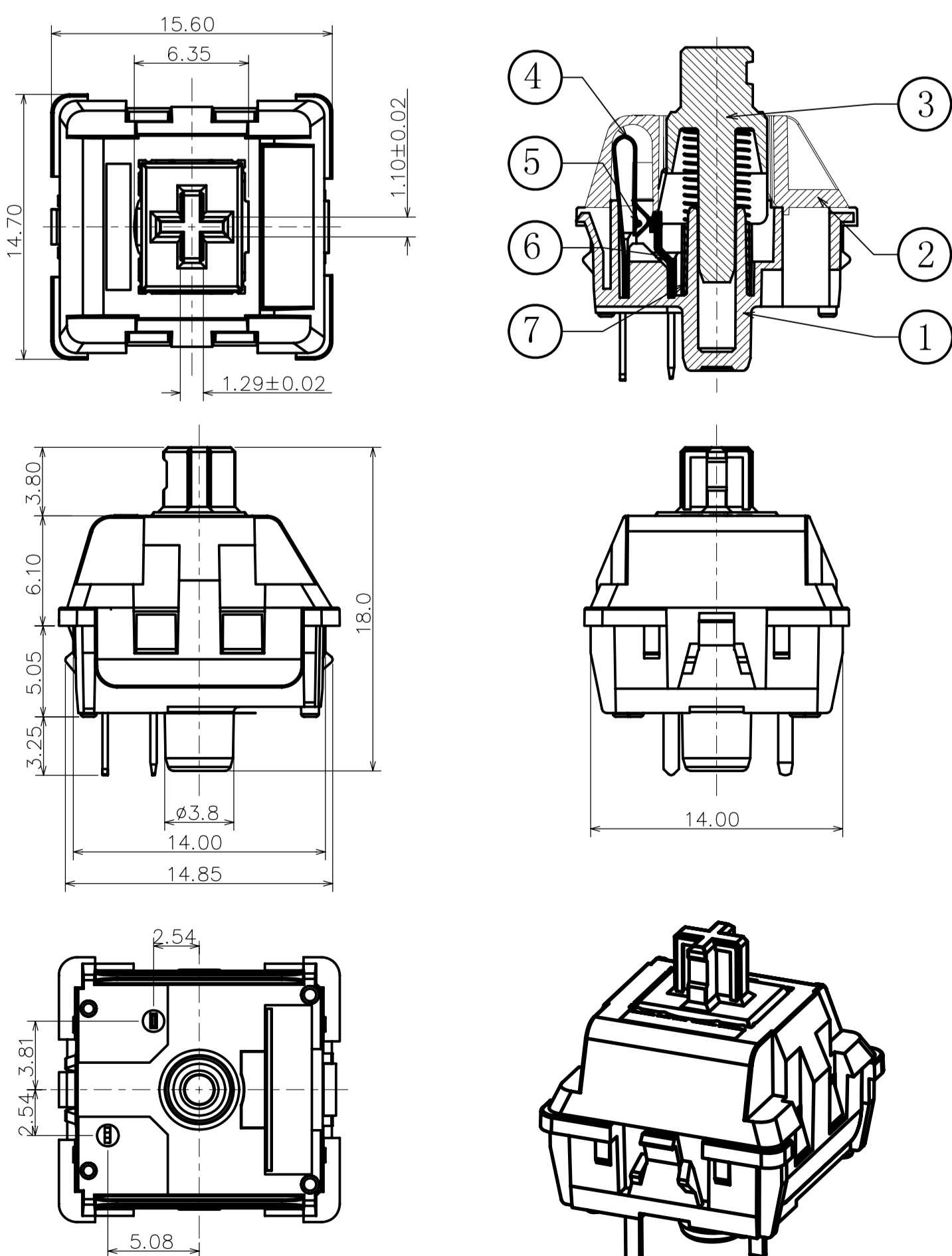
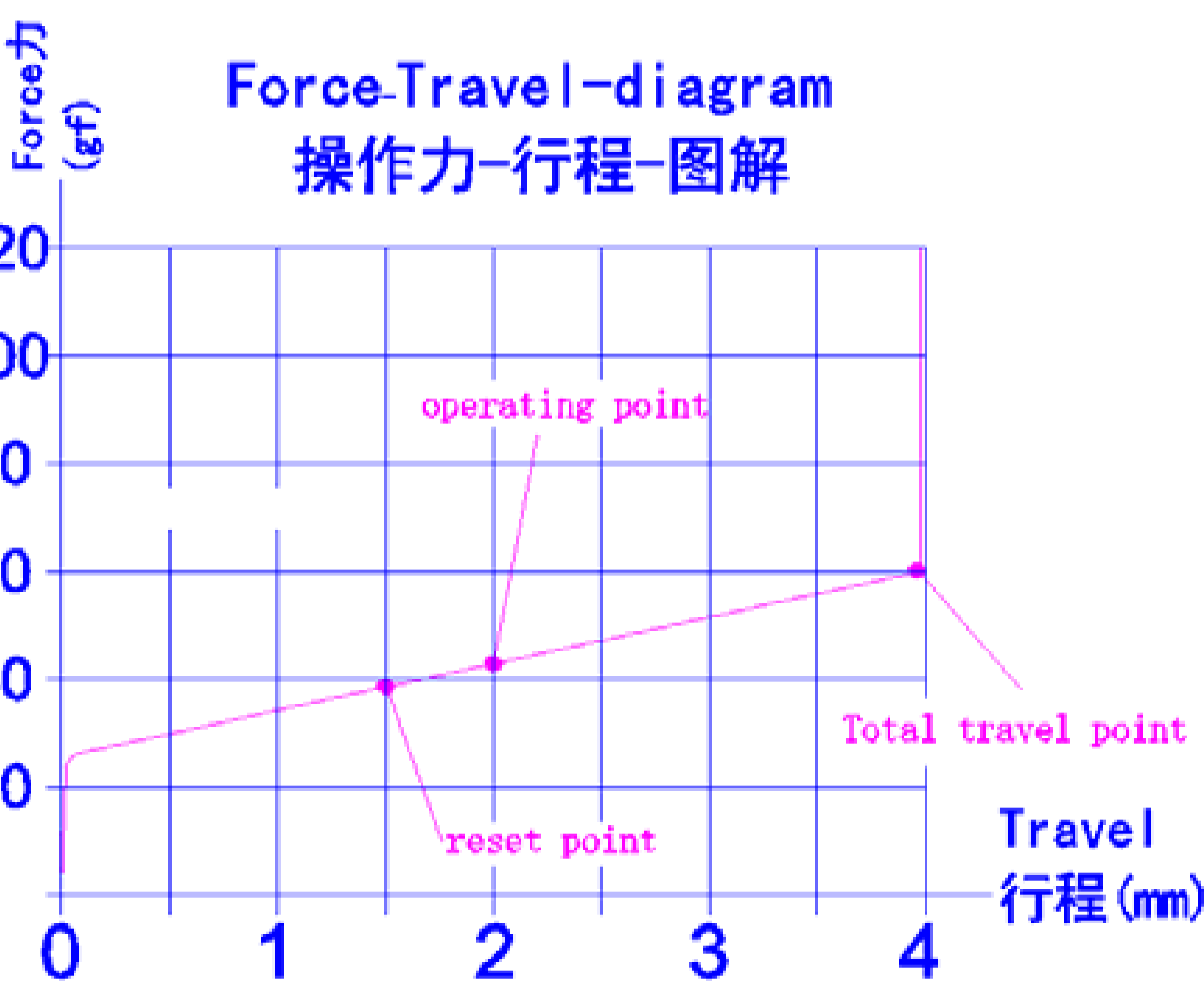
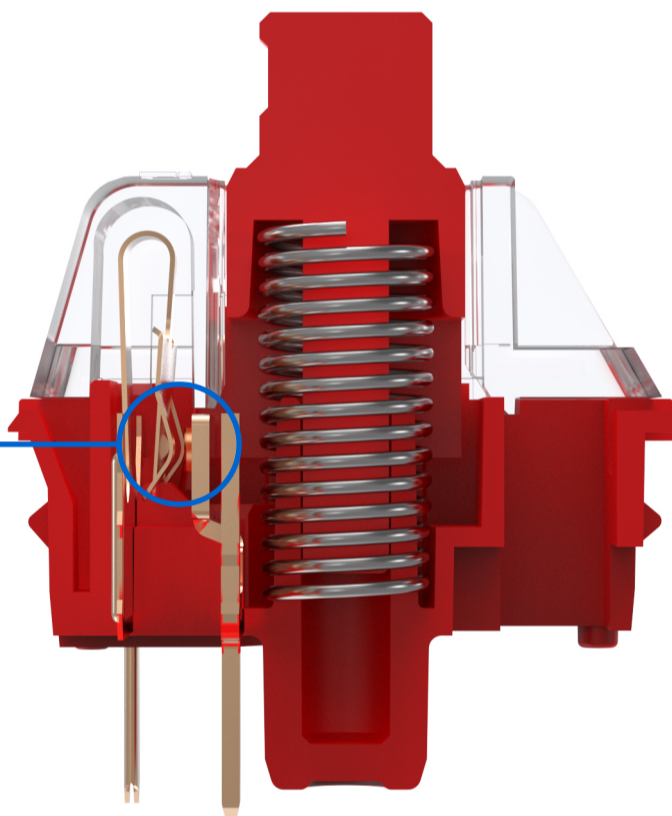

Specification :

- 1.Operation Force :42±10gf.
- 2.End Force :60±10gf.
- 3.Pretravel:2.0mm±0.4 mm.
- 4.Total travel:4.0±0.4mm.
- 5.Contact resistance:25mΩ. ≅200mΩ.
6. Insulation resistance: ≧100MΩ.
- 7.Dielectric strenght: ≧100 VAC (50~60Hz) 1 Minute.
- 8.Salt spray test: >72 hs
- 9.Test Life :50,000,000 Cycles 5 VDC.
- 10.Test condition:Perpendicular to the center of the key cap.
- 11.Using the environment:Clean and tidyenvironment.

■ Installation instructions:

- 1.Thickness of mounting plate:1.50±0.03mm.
- 2.Mounting hole size:14.0*14.0mm,the tolerance:±0.03mm.
- 3.Central hole size of PCB : ≧4.0mm.
- 4.Input voltage: ≧12V AC/DC.Working current: ≧10mA.