

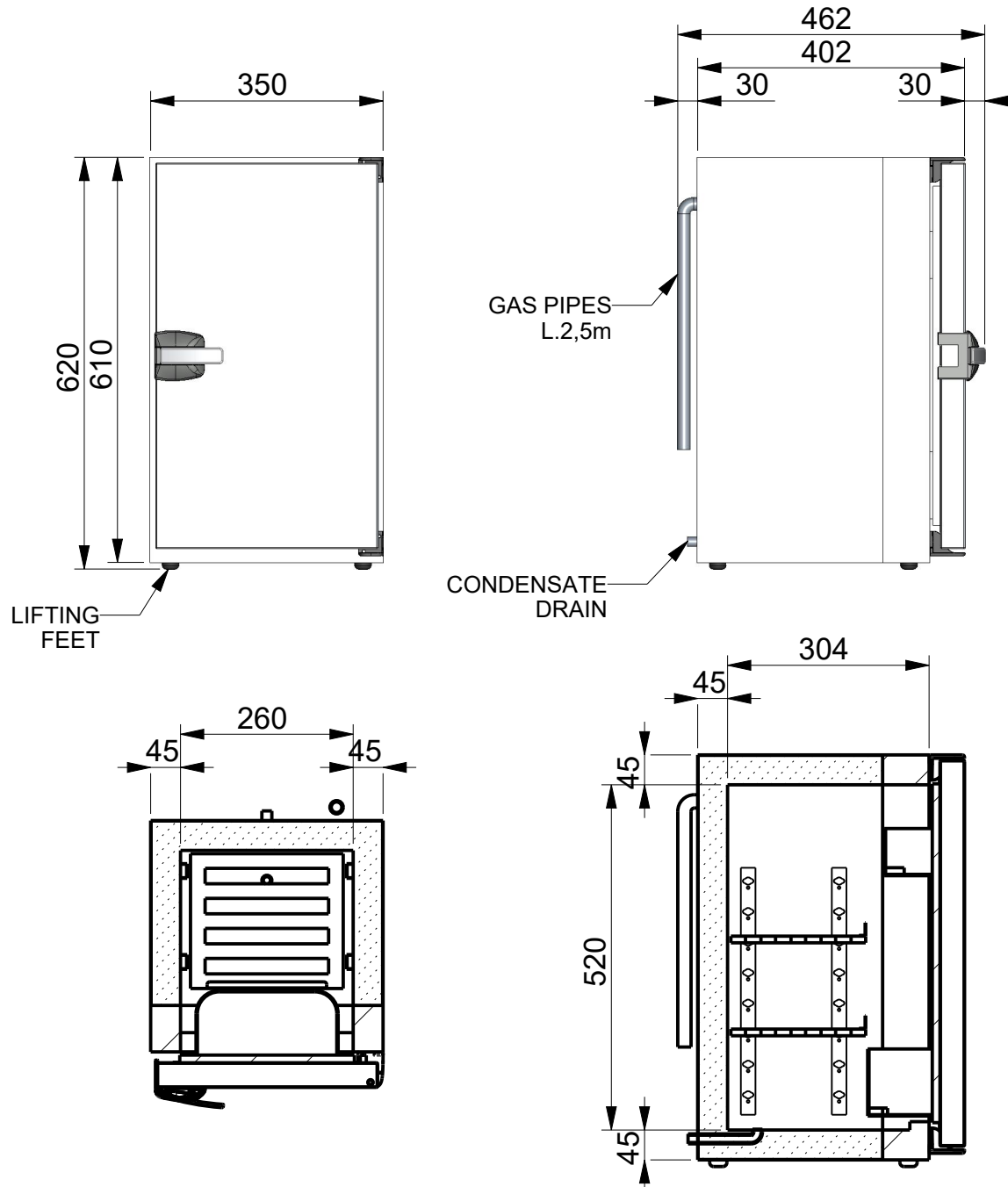

**MODEL FR50RC - Fridge capacity 42Lt**  
**Fridge (0° C +15° C) with remote compressor.**  
 The internal walls are in 304BA (polished) stainless steel, while the external front and door are in 316SB (brushed) stainless steel.  
 The refrigeration unit is available at 12 / 24Vdc, 110Vac 60Hz or at 220Vac 50Hz with forced air or water cooling.  
 Our refrigerators are made of high quality stainless steel and are also suitable for outdoor use, provided they are protected from the elements with appropriate covers.  
 Various options are also available.

CODICE PRODOTTO / PRODUCT CODE	REVISIONE / REVISION:
<h1>mod. FR50RC</h1>	R03
	DATA / DATE:
	01/01/2022
 <p>Via Confin 64, 30020 Torre di Mosto (Venezia) Italia Tel: +39 0421.325214 - Fax: +39 0421.325343        E-Mail: info@frigonautica.it - P.IVA: 03687150270  <a href="http://www.frigonautica.it">www.frigonautica.it</a></p>	
<small>         PROPRIETA' DI FRIGONAUTICA srl          Senza autorizzazione scritta della stessa il presente disegno non potrà essere utilizzato per la costruzione dell'oggetto rappresentato, nè venire comunicato a terzi o riprodotto anche parzialmente. La società proprietaria tutela i propri diritti a rigor di legge.          ALL PROPRIETARY RIGHT RESERVED BY FRIGONAUTICA srl          This drawing shall not be reproduced also partially or in any way utilized for the manufacture of the component or unit herein illustrated and must not be released to other parties without written consent. Any infringement will be legally pursued.       </small>	

# SPECIFICATIONS



## FEATURES CABINET FR50RC

- W350xD462xH610 [mm] Fridge capacity 42 Lt;
- Range of temperature from 0°C to +15°C;
- External plasticized galvanized metal sheet;
- Internal walls in 304BA stainless steel (Polished);
- Front part and door in 316SB stainless steel (Brushed);
- Predisposition for door opening on both the right and left;
- Polyurethane foam insulation thickness 45mm;
- Weight 18Kg (without compressor);
- Condensate drainage connected by ¼ coupling;
- N. 02 stainless steel shelves adjustable in height;
- N. 02 stainless steel bottle holders;
- Gas expansion by capillary pipe;
- Mechanical thermostat for temperature control;
- External compressor (pipe length 2,5m);
- Internal led light with door switch;
- In case of external use, do not expose the refrigerator directly to atmospheric agents, but protect it adequately with special covers.

CODICE PRODOTTO / PRODUCT CODE	REVISIONE / REVISION:
<h1>mod. FR50RC</h1>	R03
	DATA / DATE:
	01/01/2022
 <p><i>Il freddo a misura di mare</i></p>	
<p>Via Confin 64, 30020 Torre di Mosto (Venezia) Italia Tel: +39 0421.325214 - Fax: +39 0421.325343 E-Mail: info@frignonautica.it - P.IVA: 03687150270 www.frigonautica.it</p>	
<p><small>PROPRIETA' DI FRIGNAUTICA srl Senza autorizzazione scritta della stessa il presente disegno non potrà essere utilizzato per la costruzione dell'oggetto rappresentato, nè venire comunicato a terzi o riprodotto anche parzialmente. La società proprietaria tutela i propri diritti a rigor di legge. ALL PROPRIETARY RIGHT RESERVED BY FRIGNAUTICA srl This drawing shall not be reproduced also partially or in any way utilized for the manufacture of the component or unit herein illustrated and must not be released to other parties without written consent. Any infringement will be legally pursued.</small></p>	

# ACCESSORIES - OPTIONAL

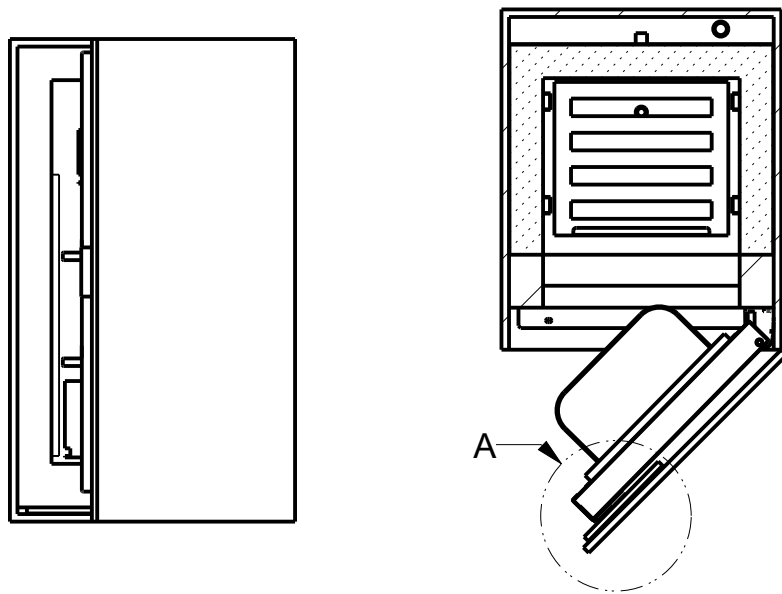

## - DOOR SLIDING KIT

Sliding mechanism which replaces the handle in the case of a fully built-in installation with an exterior cabinet door.

VIEW - A-

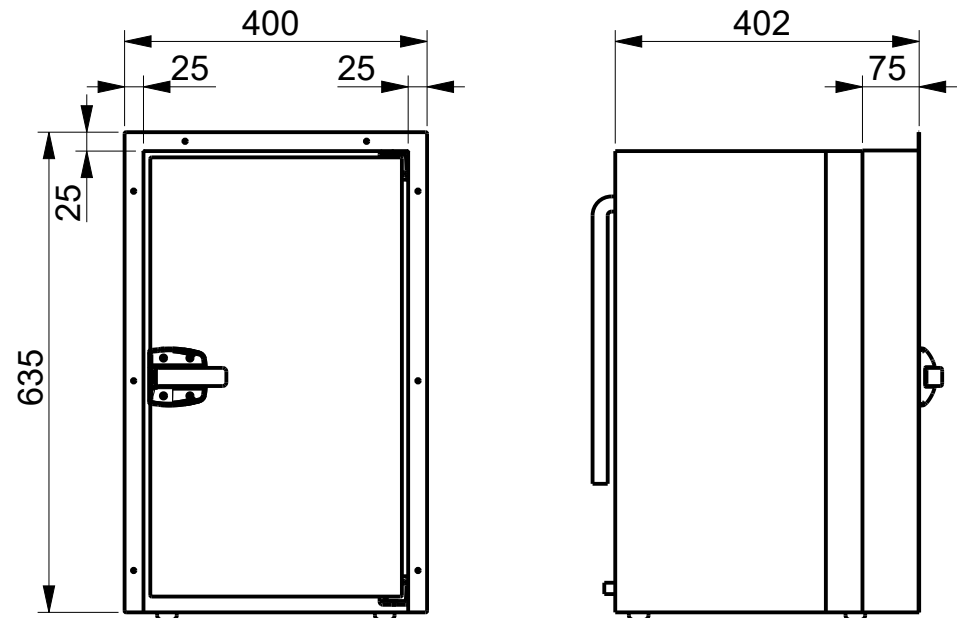
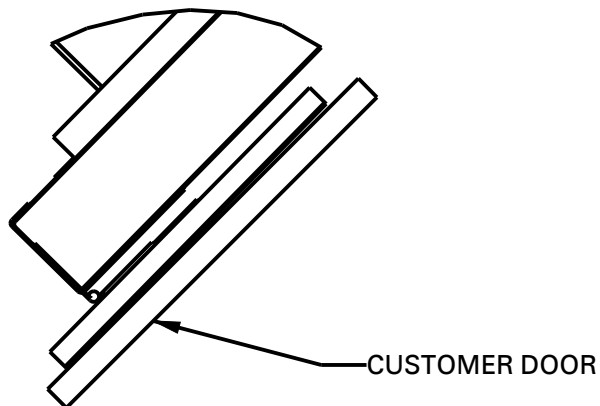

## - FIXING KIT

Special stainless steel frame which allows to easily fix the cupboard to the furniture.

CODICE PRODOTTO / PRODUCT CODE	REVISIONE / REVISION:
<h1>mod. FR50RC</h1>	R03
	DATA / DATE:
	01/01/2022
 <b>Frigonautica</b> <i>Il freddo a misura di mare</i>	
Via Confin 64, 30020 Torre di Mosto (Venezia) Italia Tel: +39 0421.325214 - Fax: +39 0421.325343 E-Mail: info@frigonautica.it - P.IVA: 03687150270 www.frigonautica.it	
<small>                 PROPRIETA' DI FRIGONAUTICA srl                  Senza autorizzazione scritta della stessa il presente disegno non potrà essere utilizzato per la costruzione dell'oggetto rappresentato, nè venire comunicato a terzi o riprodotto anche parzialmente. La società proprietaria tutela i propri diritti a rigor di legge.                  ALL PROPRIETARY RIGHT RESERVED BY FRIGONAUTICA srl                  This drawing shall not be reproduced also partially or in any way utilized for the manufacture of the component or unit herein illustrated and must not be released to other parties without written consent. Any infringement will be legally pursued.             </small>	

## ACCESSORIES - OPTIONAL

STAINLESS STEEL PLATE

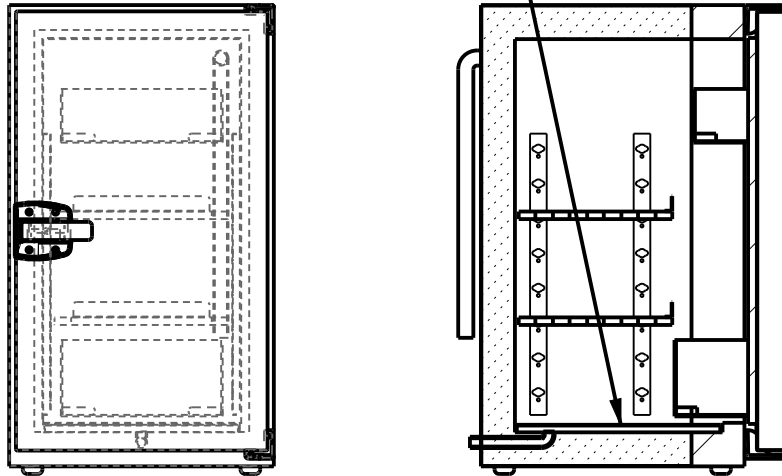

- STAINLESS STEEL PLATE FOR BOTTOM  
Raised stainless steel plate keeps foods out of  
condensation water in the bottom of the fridge.

CODICE PRODOTTO / PRODUCT CODE	REVISIONE / REVISION:
mod. FR50RC	R03
	DATA / DATE:
	01/01/2022
 <b>Frigonautica</b> <i>Il freddo a misura di mare</i>	
Via Confin 64, 30020 Torre di Mosto (Venezia) Italia Tel: +39 0421.325214 - Fax: +39 0421.325343 E-Mail: <a href="mailto:info@frigonautica.it">info@frigonautica.it</a> - P.IVA: 03687150270 <a href="http://www.frigonautica.it">www.frigonautica.it</a>	
<small>PROPRIETA' DI FRIGONAUTICA srl Senza autorizzazione scritta della stessa il presente disegno non potrà essere utilizzato per la costruzione dell'oggetto rappresentato, nè venire comunicato a terzi o riprodotto anche parzialmente. La società proprietaria tutela i propri diritti a rigor di legge. ALL PROPRIETARY RIGHT RESERVED BY FRIGONAUTICA srl This drawing shall not be reproduced also partially or in any way utilized for the manufacture of the component or unit herein illustrated and must not be released to other parties without written consent. Any infringement will be legally pursued.</small>	

## ACCESSORIES - OPTIONAL

- REMOTE ELECTRONICAL THERMOSTAT (DIGITAL THERMOSTAT)  
In order to keep the internal temperature under control and have real time indications of fridge functionality.

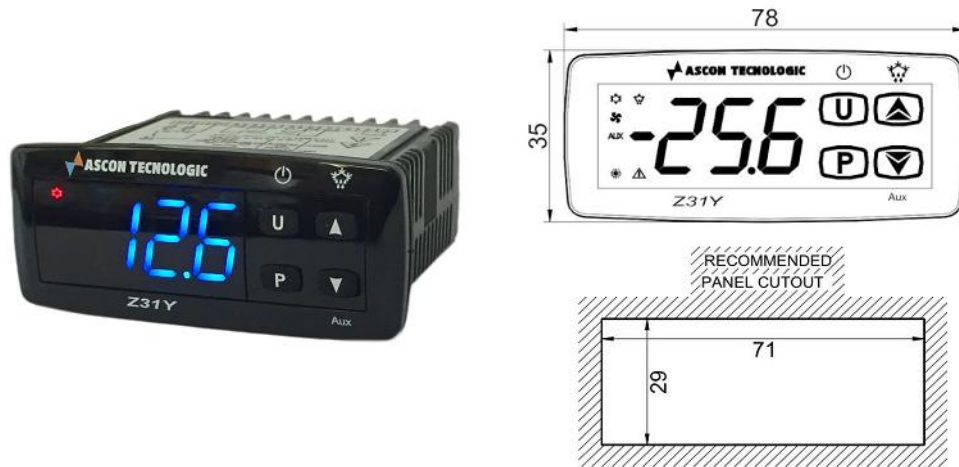

- QUICKLY COUPLINGS  
Special couplings which allow to separate cabinet from compressor avoiding gas losing. That's very useful during installation which do not request skilled technical personnel.

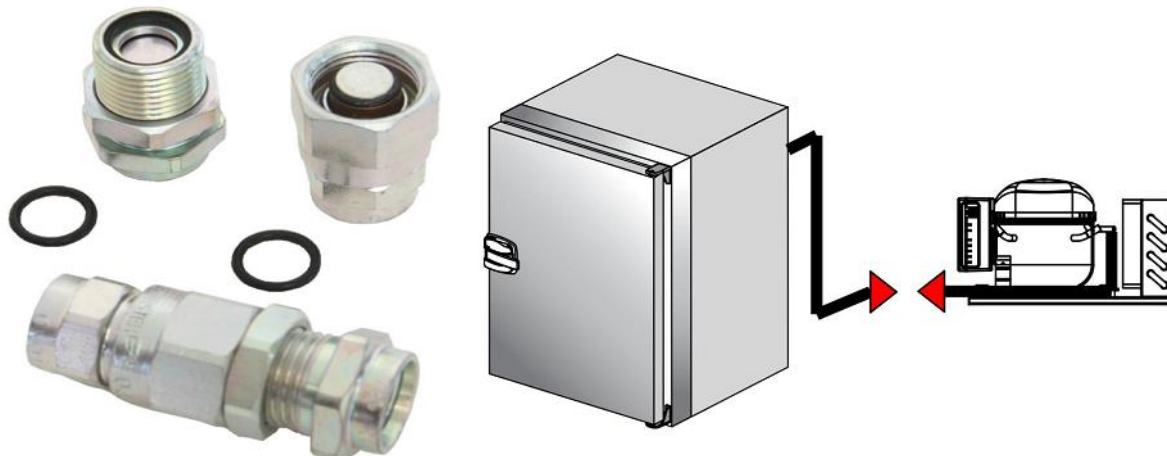

- SWITCHING POWER SUPPLY  
Compact and powerful switching power supply.  
Dimension: W120 x D270 x H50[mm] - 1,1Kg



Model	Input	Power input	Output	
RA15-110V 12Vdc	110Vac	168W	12Vdc	14A
RA15-110V 24Vdc	110Vac	168W	24Vdc	7A
RA15-220V 12Vdc	220Vac	168W	12Vdc	14A
RA15-220V 24Vdc	220Vac	168W	24Vdc	7A

CODICE PRODOTTO / PRODUCT CODE		REVISIONE / REVISION:	
<h1>mod. FR50RC</h1>		R03	
		DATA / DATE:	
		01/01/2022	
Via Confin 64, 30020 Torre di Mosto (Venezia) Italia Tel: +39 0421.325214 - Fax: +39 0421.325343 E-Mail: info@frigonautica.it - P.IVA: 03687150270 www.frigonautica.it			
<small>                     PROPRIETA' DI FRIGONAUTICA srl                      Senza autorizzazione scritta della stessa il presente disegno non potrà essere utilizzato per la costruzione dell'oggetto rappresentato, nè venire comunicato a terzi o riprodotto anche parzialmente. La società proprietaria tutela i propri diritti a rigor di legge.                      ALL PROPRIETY RIGHT RESERVED BY FRIGONAUTICA srl                      This drawing shall not be reproduced also partially or in any way utilized for the manufacture of the component or unit herein illustrated and must not be released to other parties without written consent. Any infringement will be legally pursued.                 </small>			

# AIRTIGHT UNITS

- COOLED BY FORCED AIR

UNIT  
EV80

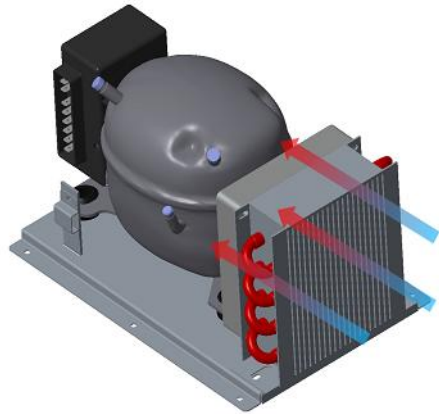

- COOLED BY SEA WATER

UNIT  
EAF80

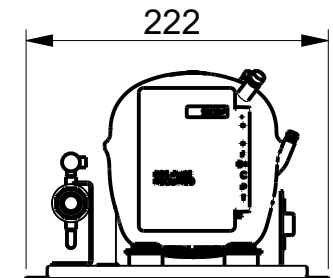
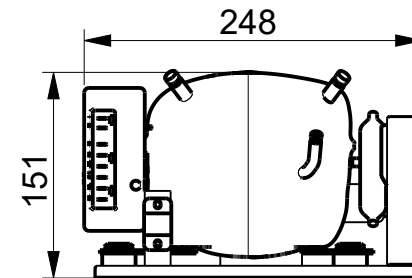
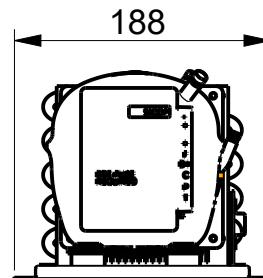
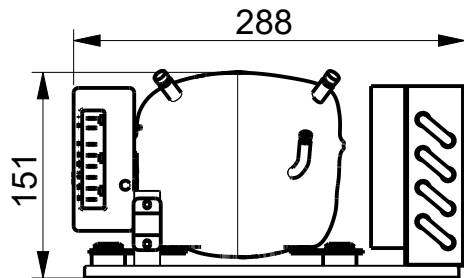
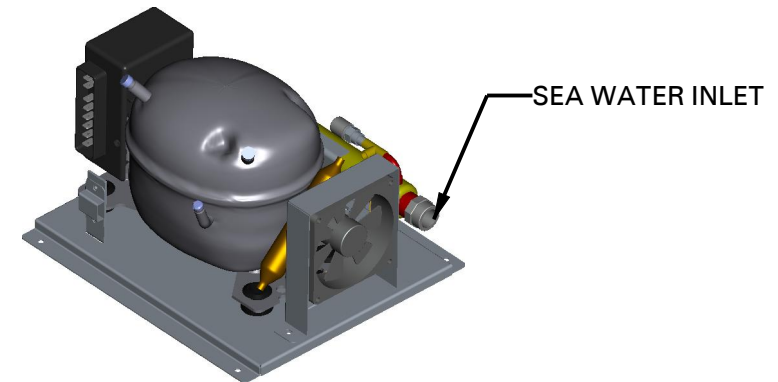

The refrigeration units can be cooled with forced air, or cooled with sea water by means of a circulation pump.

The location of the refrigeration unit must be well ventilated and must allow adequate air passage. It is essential to provide good ventilation to the refrigerating unit. The correct working of the system is guaranteed if there is at least 100m<sup>3</sup>/h airflow to the compressor. We suggest air opening at least 400cm<sup>2</sup> for suction and at least 400cm<sup>2</sup> for warm air exit.

The available voltages are 12 / 24Vdc - 220Vac 50Hz - 110Vac 60Hz.

CODICE PRODOTTO / PRODUCT CODE	REVISIONE / REVISION:
<h1>mod. FR50RC</h1>	R03
	DATA / DATE:
	01/01/2022
 <b>Frigonautica</b> <i>Il freddo a misura di mare</i>	
Via Confin 64, 30020 Torre di Mosto (Venezia) Italia Tel: +39 0421.325214 - Fax: +39 0421.325343 E-Mail: info@frignonautica.it - P.IVA: 03687150270 www.frigonautica.it	
<small>                 PROPRIETA' DI FRIGONAUTICA srl                  Senza autorizzazione scritta della stessa il presente disegno non potrà essere utilizzato per la costruzione dell'oggetto rappresentato, nè venire comunicato a terzi o riprodotto anche parzialmente. La società proprietaria tutela i propri diritti a rigor di legge.                  ALL PROPRIETARY RIGHT RESERVED BY FRIGONAUTICA srl                  This drawing shall not be reproduced also partially or in any way utilized for the manufacture of the component or unit herein illustrated and must not be released to other parties without written consent. Any infringement will be legally pursued.             </small>	