

SPECIFICATIONS

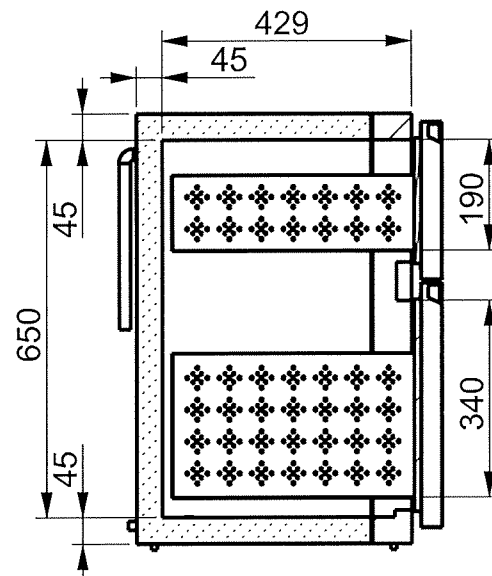
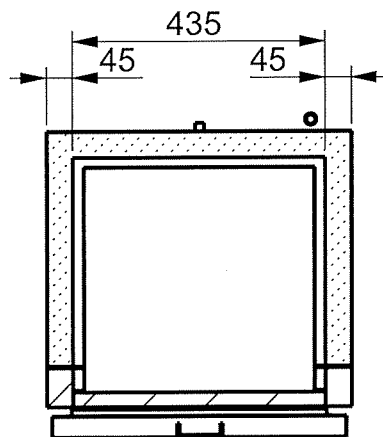
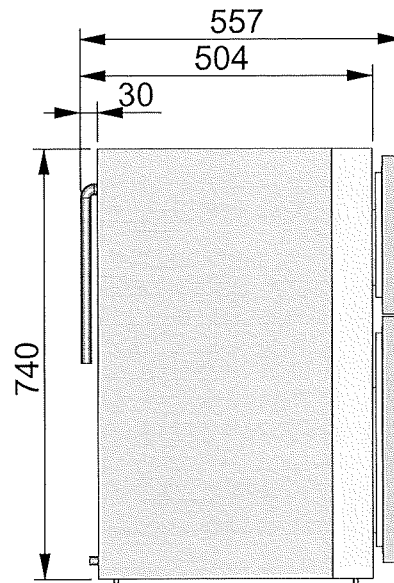
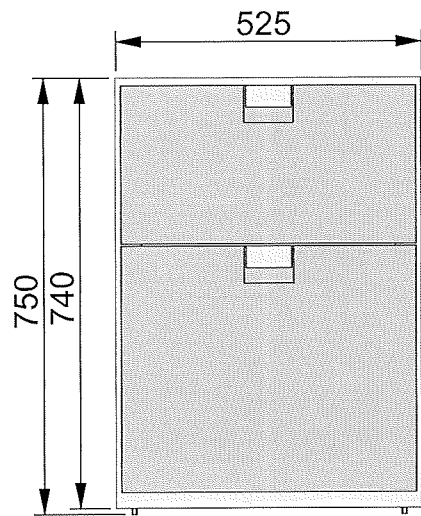

FEATURES CABINET FC4

- W525xD557xH740 capacity of the fridge 130Lt;
- Range of temperature from 0°C to +15°C;
- External plasticized galvanized metal sheet;
- Internal walls in polished stainless steel 304BA;
- External front and door in stainless steel 316SB;
- Polyurethane foam insulation thickness 45mm;
- Condensate drainage connected by ¼ coupling;
- Internal dimension drawer 01: L390 x D416 x H190
- Internal dimension drawer 02: L390 x D416 x H340
- Integrated copper tube evaporator;
- Gas expansion by capillary pipe;
- Mechanical thermostat for temperature control;
- External compressor (pipe length 2,5m);
- Internal led light;
- Do not place the refrigerator directly to atmospheric agents, but cover it with proper protections.

CODICE PRODOTTO / PRODUCT CODE	REVISIONE / REVISION:
<h1>mod. FC4</h1>	R02
	DATA / DATE:
	04/04/2018



Via Confin 64, 30020 Torre di Mosto (Venezia) Italia Tel: +39 0421.325214 - Fax: +39 0421.325343
 E-Mail: info@frigonautica.it - P.IVA: 03687150270
www.frigonautica.it

PROPRIETA' DI FRIGONAUTICA srl
 Senza autorizzazione scritta della stessa il presente disegno non potrà essere utilizzato per la costruzione dell'oggetto rappresentato, né venire comunicato a terzi o riprodotto anche parzialmente. La società proprietaria tutela i propri diritti a rigor di legge.
 ALL PROPRIETARY RIGHT RESERVED BY FRIGONAUTICA srl
 This drawing shall not be reproduced also partially or in any way utilized for the manufacture of the component or unit herein illustrated and must not be released to other parties without written consent. Any infringement will be legally pursued.