

SPECIFICATIONS

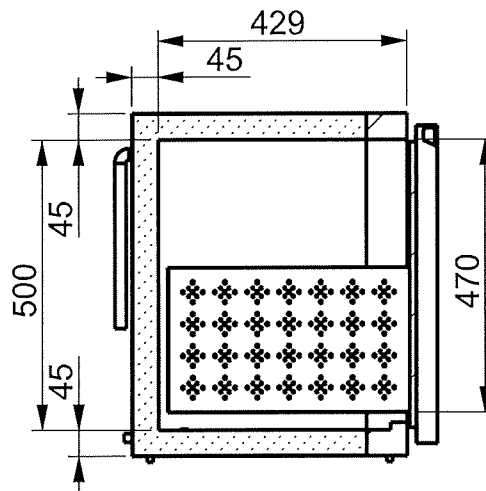
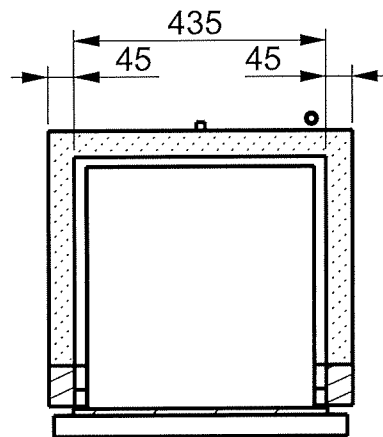
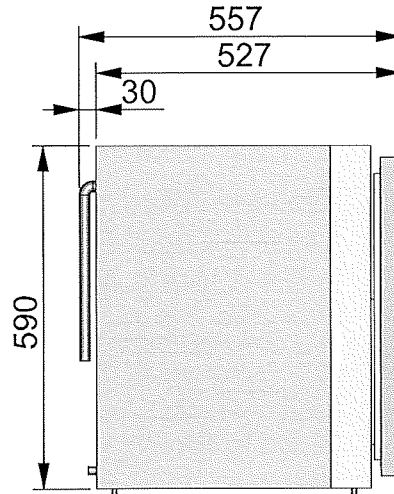
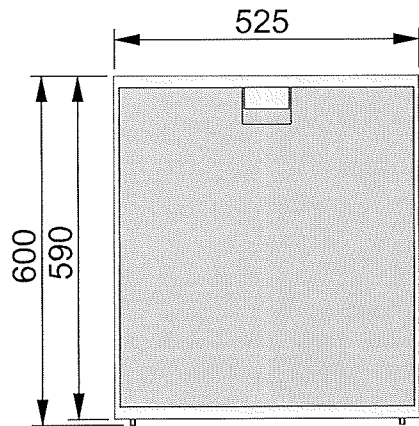

FEATURES CABINET FC1

- W525xD557xH590 capacity of the fridge 90Lt;
- Range of temperature from 0°C to +15°C;
- External plasticized galvanized metal sheet;
- Internal walls in polished stainless steel 304BA;
- External front and door in stainless steel 316SB;
- Polyurethane foam insulation thickness 45mm;
- Condensate drainage connected by ¼ coupling;
- Internal dimension drawer 01: L390 x D416 x H470
- Integrated copper tube evaporator;
- Gas expansion by capillary pipe;
- Mechanical thermostat for temperature control;
- External compressor (pipe lenght 2,5m);
- Internal led light;
- Do not place the refrigerator directly to atmospheric agents, but cover it with proper protections.

CODICE PRODOTTO / PRODUCT CODE	REVISIONE / REVISION:
mod. FC1	R02
	DATA / DATE:
	04/04/2018



Via Confin 64, 30020 Torre di Mosto (Venezia) Italia Tel: +39 0421.325214 - Fax: +39 0421.325343
 E-Mail: info@frignonautica.it - P.IVA: 03687150270
www.frigonautica.it

PROPRIETA' DI FRIGNONAUTICA srl
 Senza autorizzazione scritta della stessa il presente disegno non potrà essere utilizzato per la costruzione dell'oggetto rappresentato, nè venire comunicato a terzi o riprodotto anche parzialmente. La società proprietaria tutela i propri diritti a rigor di legge.
 ALL PROPRIETRY RIGHT RESERVED BY FRIGNONAUTICA srl
 This drawing shall not be reproduced also partially or in any way utilized for the manufacture of the component or unit herein illustrated and must not be released to other parties without written consent. Any infringement will be legally pursued.